

## High-Speed Drivers with SPDT JFET Switches

### FEATURES

- Constant On-Resistance Over Entire Analog Range
- Low Leakage
- Low Crosstalk
- Low Rad Hardness

### BENEFITS

- Low Distortion
- Eliminates Large Signal Errors
- High Precision
- High Bandwidth Capability
- Fault Protection

### APPLICATIONS

- Audio Switching
- Video Switching
- Sample/Hold
- Guidance and Control Systems
- Telemetry

### DESCRIPTION

The DG186/187/188 are precision single-pole, double-throw (SPDT) analog switches designed to provide accurate switching of video and audio signals. This series is ideally suited for applications requiring a constant on-resistance over the entire analog range.

The major difference in the devices is the on-resistance (DG186—10  $\Omega$ , DG187—30  $\Omega$ , DG188—75  $\Omega$ ). Reduced errors are achieved through low leakage current ( $I_{D(on)}$  < 2 nA). Applications which benefit from the flat JFET

on-resistance include audio switching, video switching, and data acquisition.

To achieve fast and accurate switch performance, each device comprises two n-channel JFET transistors and a TTL compatible bipolar driver. The driver is designed to achieve break-before-make switching action, eliminating the inadvertent shorting between channels and the crosstalk which would result. In the on state, each switch conducts current equally well in either direction. In the off condition, the switches will block up to 20 V peak-to-peak, with feedthrough of less than -60 dB at 10 MHz.

### FUNCTIONAL BLOCK DIAGRAM AND PIN CONFIGURATION

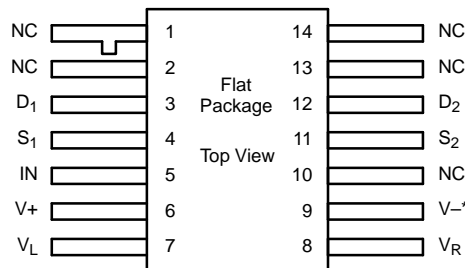
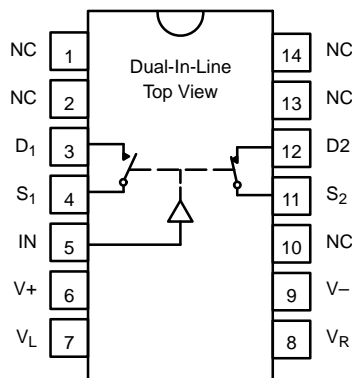

Refer to JAN38510 Information, Military Section

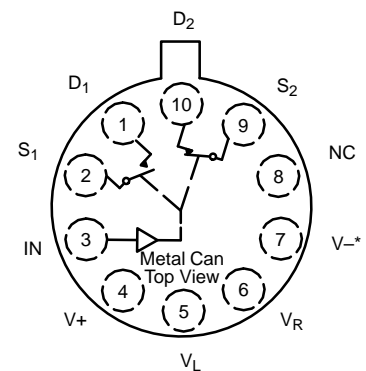

\*COMMON TO SUBSTRATE AND CASE

TRUTH TABLE		
Logic	SW <sub>1</sub>	SW <sub>2</sub>
0	OFF	ON
1	ON	OFF

Logic "0"  $\leq$  0.8 V  
Logic "1"  $\geq$  2.0 V

ORDERING INFORMATION		
Temp Range	Package	Part Number
-55 to 125°C	10-Pin Metal Can	DG186AA/883
		DG187AA/883, JM38510/11105BIA
		DG188AA/883, JM38510/11106BIA
	14-Pin Sidebraze	DG186AP/883
		DG187AP/883, JM38510/11105BCA
		DG188AP
	14-Pin Flat Pack	DG188AP/883, JM38510/11106BCA
		JM38510/11105BXA

**ABSOLUTE MAXIMUM RATINGS**

V+ to V-	36 V	Current (S or D) DG187, DG188	30 mA
V+ to V <sub>D</sub>	33 V	Current (All Other Pins)	30 mA
V <sub>D</sub> to V-	33 V	Storage Temperature	-65 to 150°C
V <sub>D</sub> to V <sub>D</sub>	±22 V	Power Dissipation <sup>a</sup>	
V <sub>L</sub> to V-	36 V	10-Pin Metal Can <sup>b</sup>	450 mW
V <sub>L</sub> to V <sub>IN</sub>	8 V	14-Pin Sidebraze <sup>c</sup>	825 mW
V <sub>L</sub> to V <sub>R</sub>	8 V	14-Pin Flat Pack <sup>d</sup>	900 mW
V <sub>IN</sub> to V <sub>R</sub>	8 V	Notes:	
V <sub>R</sub> to V-	27 V	a. All leads welded or soldered to PC Board.	
V <sub>R</sub> to V <sub>IN</sub>	2 V	b. Derate 6 mW/°C above 75°C	
Current (S or D) DG186	200 mA	c. Derate 11 mW/°C above 75°C	
		d. Derate 10 mW/°C above 75°C	

**SCHEMATIC DIAGRAM (TYPICAL CHANNEL)**

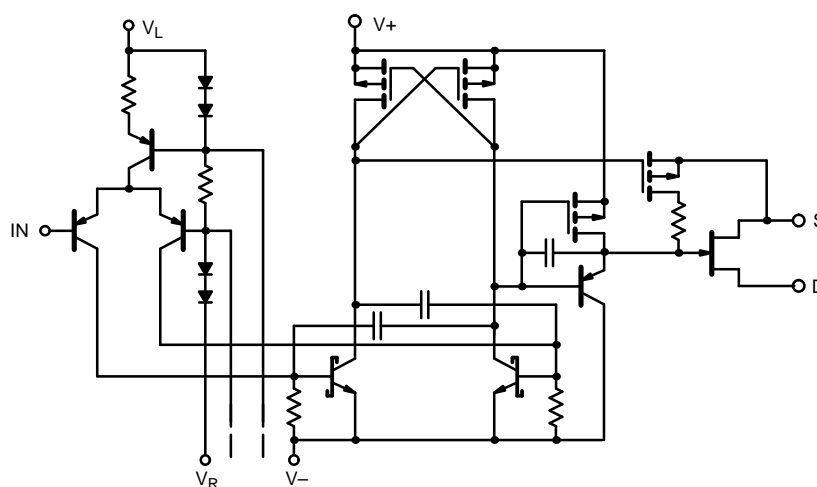

FIGURE 1.



SPECIFICATIONS <sup>a</sup> For DG186								
Parameter	Symbol	Test Conditions Unless Specified $V_+ = 15\text{ V}, V_- = -15\text{ V}, V_L = 5\text{ V}$ $V_R = 0\text{ V}, V_{IN} = 0.8\text{ or }2\text{ V}^f$	Temp <sup>b</sup>	Limits			Unit	
				Min <sup>d</sup>	Typ <sup>c</sup>	Max <sup>d</sup>		
<b>Analog Switch</b>								
Analog Signal Range <sup>e</sup>	$V_{ANALOG}$		Full	-7.5		15	V	
Drain-Source On-Resistance	$r_{DS(on)}$	$I_S = -10\text{ mA}, V_D = -7.5\text{ V}$	Room Full		7.5	10 20	$\Omega$	
Source Off Leakage Current	$I_{S(off)}$	$V_S = \pm 10\text{ V}, V_D = \mp 10\text{ V}$ $V_+ = 10\text{ V}, V_- = -20\text{ V}$	Room Hot		0.05	10 1000	nA	
		$V_S = \pm 7.5\text{ V}, V_D = \mp 7.5\text{ V}$	Room Hot		0.05	10 1000		
Drain Off Leakage Current	$I_{D(off)}$	$V_S = \pm 10\text{ V}, V_D = \mp 10\text{ V}$ $V_+ = 10\text{ V}, V_- = -20\text{ V}$	Room Hot		0.04	10 1000		
		$V_S = \pm 7.5\text{ V}, V_D = \mp 7.5\text{ V}$	Room Hot		0.03	10 1000		
Channel On Leakage Current	$I_{D(on)}$	$V_D = V_S = \pm 7.5\text{ V}$	Room Hot	-2 -200	-0.1			
Saturation Drain Current	$I_{DSS}$	2 ms Pulse Duration	Room		300		mA	
<b>Digital Input</b>								
Input Current with Input Voltage High	$I_{INH}$	$V_{IN} = 5\text{ V}$	Room Hot		<0.01	10 20	$\mu\text{A}$	
Input Current with Input Voltage Low	$I_{INL}$	$V_{IN} = 0\text{ V}$	Full	-250	-30			
<b>Dynamic Characteristics</b>								
Turn-On Time	$t_{on}$	See Switching Time Test Circuit	Room		240	400	ns	
Turn-Off Time	$t_{off}$		Room		140	200		
Source-Off Capacitance	$C_{S(off)}$	f = 1 MHz	Room		21		pF	
Drain-Off Capacitance	$C_{D(off)}$		$V_S = -5\text{ V}, I_D = 0$	Room		17		
Channel-On Capacitance	$C_{D(on)}$		$V_D = -5\text{ V}, I_S = 0$	Room		17		
Off Isolation	OIRR	$f = 1\text{ MHz}, R_L = 75\ \Omega$	Room		>55		dB	
<b>Power Supplies</b>								
Positive Supply Current	$I_+$	$V_{IN} = 0\text{ V}, \text{ or }5\text{ V}$	Room			0.8	mA	
Negative Supply Current	$I_-$		Room	-3				
Logic Supply Current	$I_L$		Room			3.2		
Reference Supply Current	$I_R$		Room	-2				

Notes:

- a. Refer to PROCESS OPTION FLOWCHART.
- b. Room = 25°C, Full = as determined by the operating temperature suffix.
- c. Typical values are for DESIGN AID ONLY, not guaranteed nor subject to production testing.
- d. The algebraic convention whereby the most negative value is a minimum and the most positive a maximum, is used in this data sheet.
- e. Guaranteed by design, not subject to production test.
- f.  $V_{IN}$  = input voltage to perform proper function.



SPECIFICATIONS <sup>a</sup> For DG187								
Parameter	Symbol	Test Conditions Unless Specified $V_+ = 15\text{ V}, V_- = -15\text{ V}, V_L = 5\text{ V}$ $V_R = 0\text{ V}, V_{IN} = 0.8\text{ or }2\text{ V}^f$	Temp <sup>b</sup>	Limits			Unit	
				Min <sup>d</sup>	Typ <sup>c</sup>	Max <sup>d</sup>		
<b>Analog Switch</b>								
Analog Signal Range <sup>e</sup>	$V_{ANALOG}$		Full	-7.5		15	V	
Drain-Source On-Resistance	$r_{DS(on)}$	$I_S = -10\text{ mA}, V_D = -7.5\text{ V}$	Room Full		22	30 60	$\Omega$	
Source Off Leakage Current	$I_{S(off)}$	$V_S = \pm 10\text{ V}, V_D = \mp 10\text{ V}$ $V_+ = 10\text{ V}, V_- = -20\text{ V}$	Room Hot		0.06	1 100	nA	
		$V_S = \pm 7.5\text{ V}, V_D = \mp 7.5\text{ V}$	Room Hot		0.13	1 100		
Drain Off Leakage Current	$I_{D(off)}$	$V_S = \pm 10\text{ V}, V_D = \mp 10\text{ V}$ $V_+ = 10\text{ V}, V_- = -20\text{ V}$	Room Hot		0.04	1 100		
		$V_S = \pm 7.5\text{ V}, V_D = \mp 7.5\text{ V}$	Room Hot		0.03	1 100		
Channel On Leakage Current	$I_{D(on)}$	$V_D = V_S = \pm 7.5\text{ V}$	Room Hot	-2 -200	-0.02			
<b>Digital Input</b>								
Input Current with Input Voltage High	$I_{INH}$	$V_{IN} = 5\text{ V}$	Room Hot		<0.01	10 20	$\mu\text{A}$	
Input Current with Input Voltage Low	$I_{INL}$	$V_{IN} = 0\text{ V}$	Full	-250	-30			
<b>Dynamic Characteristics</b>								
Turn-On Time	$t_{on}$	See Switching Time Test Circuit	Room		85	150	ns	
Turn-Off Time	$t_{off}$		Room		95	130		
Source-Off Capacitance	$C_{S(off)}$	f = 1 MHz	Room		9		pF	
Drain-Off Capacitance	$C_{D(off)}$		$V_S = -5\text{ V}, I_D = 0$	Room		6		
Channel-On Capacitance	$C_{D(on)}$		$V_D = -5\text{ V}, I_S = 0$	Room		14		
Off Isolation	OIRR	f = 1 MHz, $R_L = 75\ \Omega$	Room		>50		dB	
<b>Power Supplies</b>								
Positive Supply Current	$I_+$	$V_{IN} = 0\text{ V}, \text{ or }5\text{ V}$	Room			0.8	mA	
Negative Supply Current	$I_-$		Room	-3				
Logic Supply Current	$I_L$		Room			3.2		
Reference Supply Current	$I_R$		Room	-2				

Notes:

- Refer to PROCESS OPTION FLOWCHART.
- Room = 25°C, Full = as determined by the operating temperature suffix.
- Typical values are for DESIGN AID ONLY, not guaranteed nor subject to production testing.
- The algebraic convention whereby the most negative value is a minimum and the most positive a maximum, is used in this data sheet.
- Guaranteed by design, not subject to production test.
- $V_{IN}$  = input voltage to perform proper function.



SPECIFICATIONS <sup>a</sup> For DG188								
Parameter	Symbol	Test Conditions Unless Otherwise Specified $V_+ = 15\text{ V}, V_- = -15\text{ V}, V_L = 5\text{ V}$ $V_R = 0\text{ V}, V_{IN} = 0.8\text{ or }2\text{ V}^f$	Temp <sup>b</sup>	Limits			Unit	
				Min <sup>d</sup>	Typ <sup>c</sup>	Max <sup>d</sup>		
<b>Analog Switch</b>								
Analog Signal Range <sup>e</sup>	$V_{ANALOG}$		Full	-10		15	V	
Drain-Source On-Resistance	$r_{DS(on)}$	$I_S = -10\text{ mA}, V_D = -7.5\text{ V}$	Room Full		35	75 150	$\Omega$	
Source Off Leakage Current	$I_{S(off)}$	$V_S = \pm 10\text{ V}, V_D = \mp 10\text{ V}$ $V_+ = 10\text{ V}, V_- = -20\text{ V}$	Room Hot		0.05	1 100	nA	
		$V_S = \pm 10\text{ V}, V_D = \mp 10\text{ V}$	Room Hot		0.07	1 100		
Drain Off Leakage Current	$I_{D(off)}$	$V_S = \pm 10\text{ V}, V_D = \mp 10\text{ V}$ $V_+ = 10\text{ V}, V_- = -20\text{ V}$	Room Hot		0.04	1 100		
		$V_S = \pm 10\text{ V}, V_D = \mp 10\text{ V}$	Room Hot		0.50	1 100		
Channel On Leakage Current	$I_{D(on)}$	$V_D = V_S = \pm 10\text{ V}$	Room Hot	-2 -200	-0.03			
<b>Digital Input</b>								
Input Current with Input Voltage High	$I_{INH}$	$V_{IN} = 5\text{ V}$	Room Hot		<0.01	10 20	$\mu\text{A}$	
Input Current with Input Voltage Low	$I_{INL}$	$V_{IN} = 0\text{ V}$	Full	-250	-30			
<b>Dynamic Characteristics</b>								
Turn-On Time	$t_{on}$	See Switching Time Test Circuit	Room		120	250	ns	
Turn-Off Time	$t_{off}$		Room		100	130		
Source-Off Capacitance	$C_{S(off)}$	$f = 1\text{ MHz}$	Room		9		pF	
Drain-Off Capacitance	$C_{D(off)}$		$V_S = -5\text{ V}, I_D = 0$	Room		6		
Channel-On Capacitance	$C_{D(on)}$		$V_D = -5\text{ V}, I_S = 0$	Room		14		
Off Isolation	OIRR	$f = 1\text{ MHz}, R_L = 75\ \Omega$	Room		>50		dB	
<b>Power Supplies</b>								
Positive Supply Current	$I_+$	$V_{IN} = 0\text{ V}, \text{ or }5\text{ V}$	Room			0.8	mA	
Negative Supply Current	$I_-$		Room	-3				
Logic Supply Current	$I_L$		Room			3.2		
Reference Supply Current	$I_R$		Room	-2				

Notes:

- a. Refer to PROCESS OPTION FLOWCHART.
- b. Room = 25°C, Full = as determined by the operating temperature suffix.
- c. Typical values are for DESIGN AID ONLY, not guaranteed nor subject to production testing.
- d. The algebraic convention whereby the most negative value is a minimum and the most positive a maximum, is used in this data sheet.
- e. Guaranteed by design, not subject to production test.
- f.  $V_{IN}$  = input voltage to perform proper function.



**TYPICAL CHARACTERISTICS (25°C UNLESS NOTED)**

Supply Current vs. Temperature

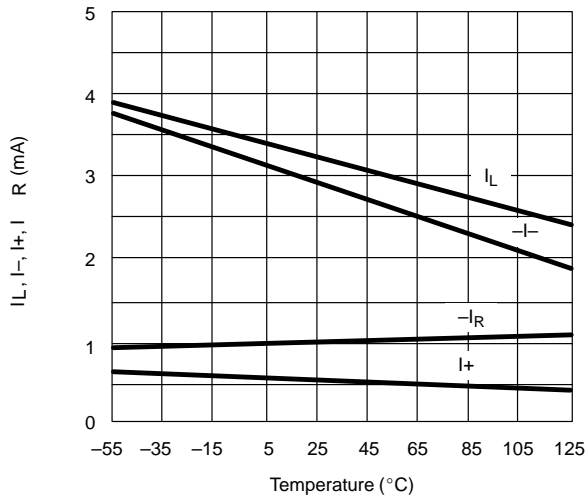

$I_{IN}$  vs.  $V_{IN}$  and Temperature

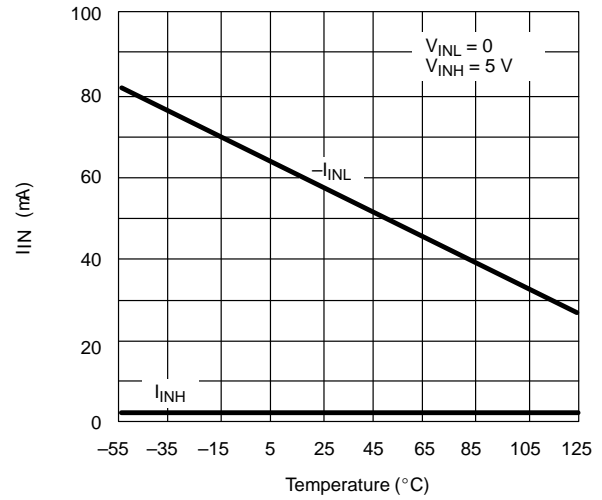

$r_{DS(on)}$  vs. Temperature

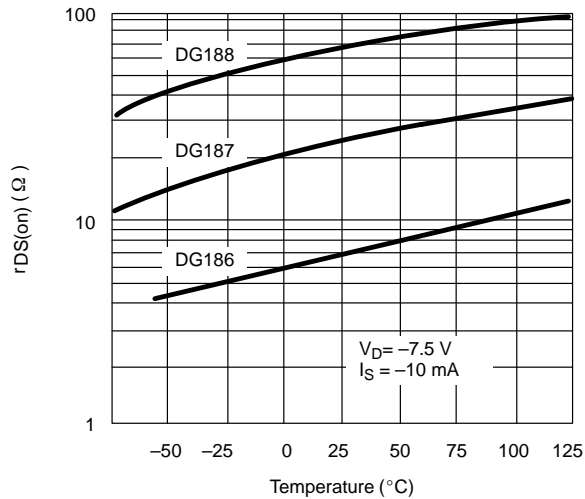

Switching Time vs.  $V_D$  and Temperature (DG186)

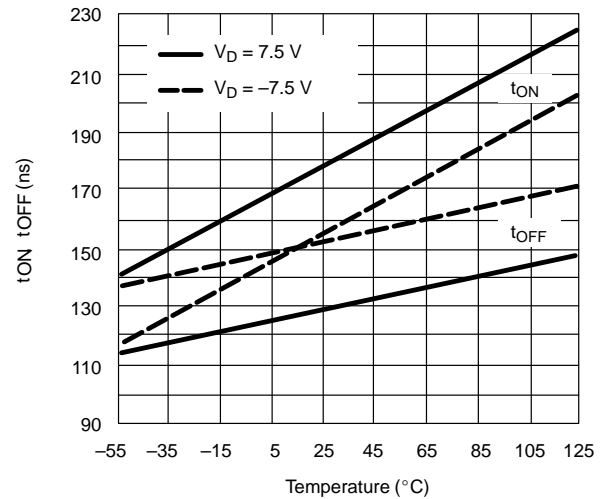

Leakage vs. Temperature (DG186)

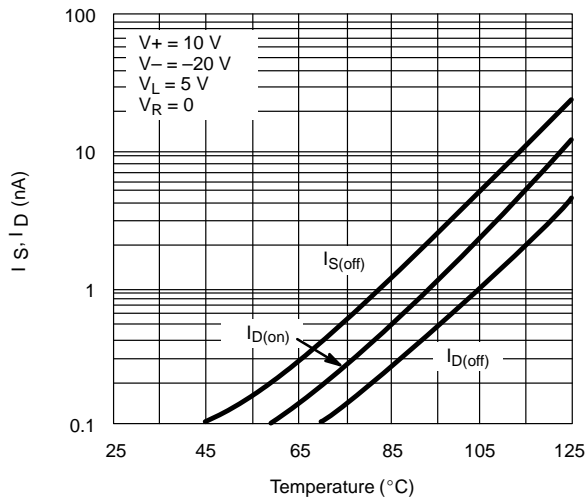

Switching Time vs.  $V_D$  and Temperature (DG187/188)

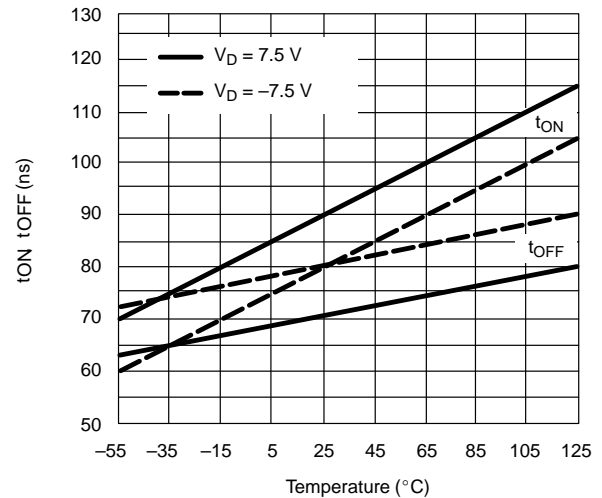



**TYPICAL CHARACTERISTICS (25°C UNLESS NOTED)**

**$I_{D(off)}$  vs. Temperature (DG187/188)**

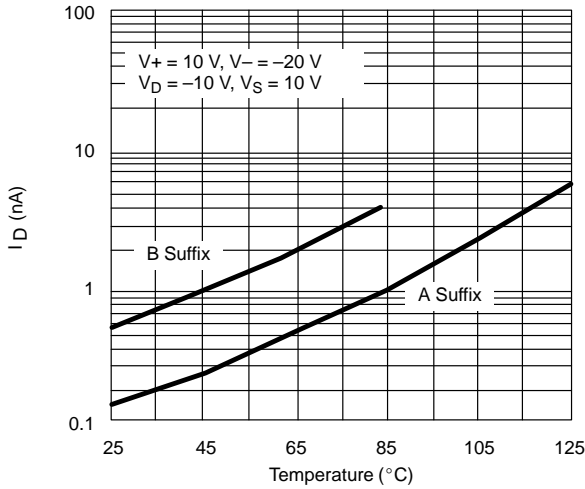

**Capacitance vs.  $V_D$  or  $V_S$  (DG186)**

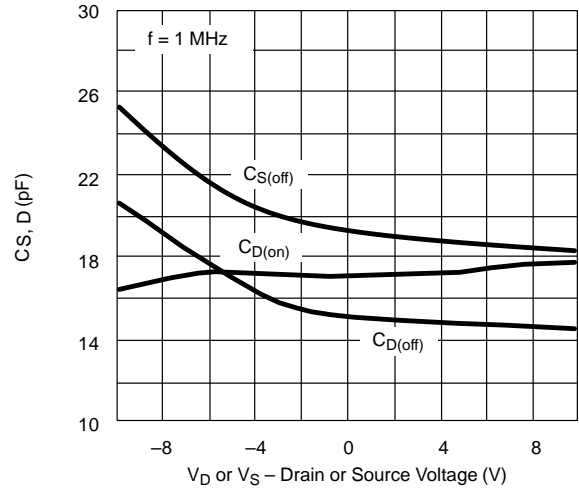

**Capacitance vs.  $V_D$  or  $V_S$  (DG187/188)**

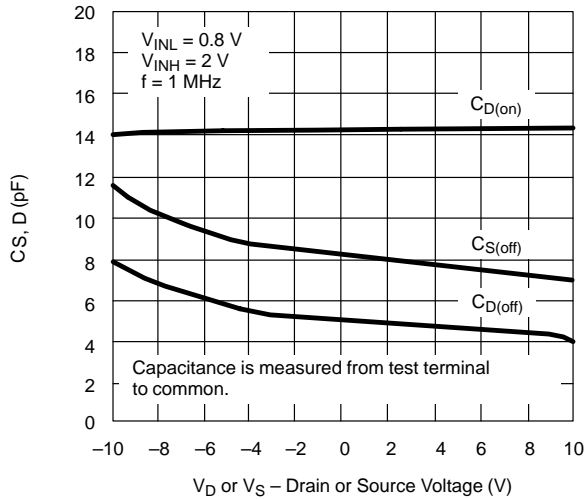

**Off Isolation vs. Frequency**

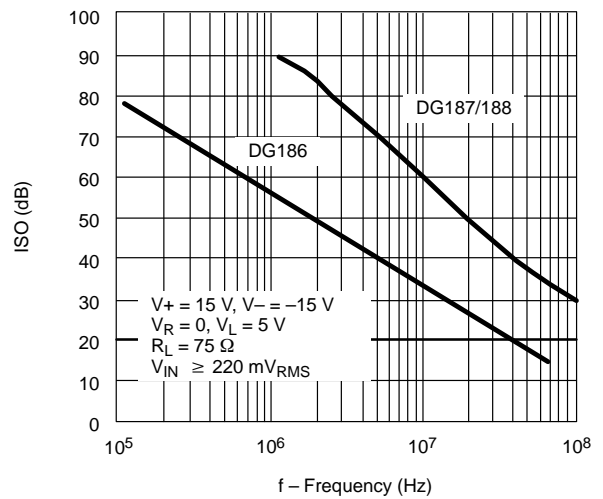

**TEST CIRCUITS**

Feedthrough due to charge injection may result in spikes at the leading and trailing edge of the output waveform.

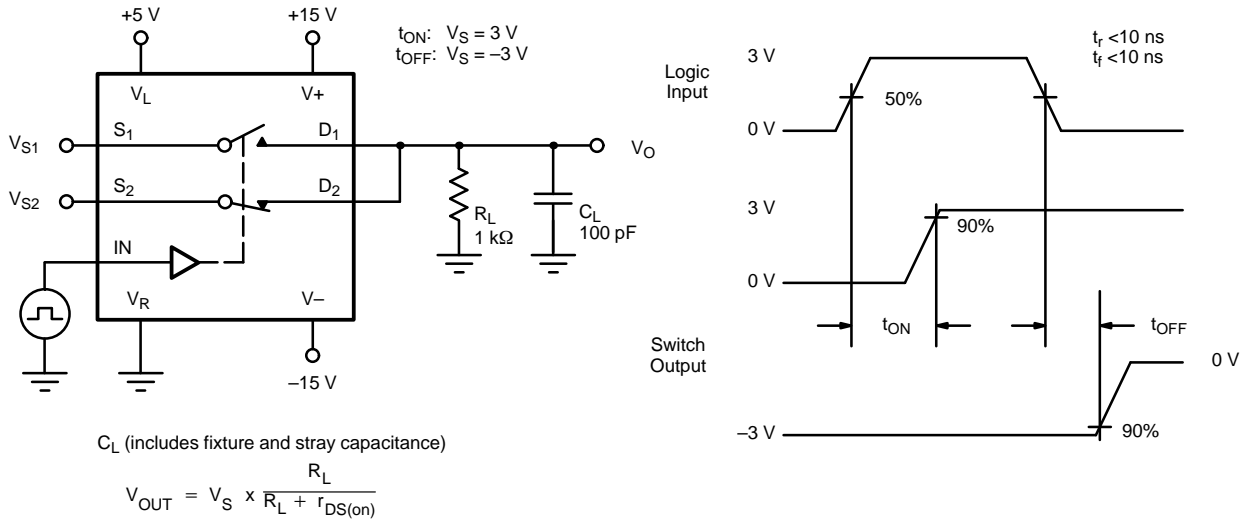

FIGURE 2. Switching Time

APPLICATION HINTS <sup>a</sup>						
Switch	V+ Positive Supply Voltage (V)	V- Negative Supply Voltage (V)	VL Logic Supply Voltage (V)	VR Reference Supply Voltage (V)	VIN Logic Input Voltage VINH(min)/VIL(max) (V)	VS Analog Voltage Range (V)
DG186 DG187	15 <sup>b</sup>	-15	5	GND	2.0/0.8	-7.5 to 15
	10	-20	5	GND	2.0/0.8	-12.5 to 10
	12	-12	5	GND	2.0/0.8	-4.5 to 12
DG188	15 <sup>b</sup>	-15	5	GND	2.0/0.8	-10 to 15
	10	-20	5	GND	2.0/0.8	-15 to 10
	12	-12	5	GND	2.0/0.8	-7 to 12

Notes:

- a. Application Hints are for DESIGN AID ONLY, not guaranteed and not subject to production testing.
- b. Electrical Parameter Chart based on V+ = 15 V, VL = 5 V, VR = GND





## Disclaimer

All product specifications and data are subject to change without notice.

Vishay Intertechnology, Inc., its affiliates, agents, and employees, and all persons acting on its or their behalf (collectively, "Vishay"), disclaim any and all liability for any errors, inaccuracies or incompleteness contained herein or in any other disclosure relating to any product.

Vishay disclaims any and all liability arising out of the use or application of any product described herein or of any information provided herein to the maximum extent permitted by law. The product specifications do not expand or otherwise modify Vishay's terms and conditions of purchase, including but not limited to the warranty expressed therein, which apply to these products.

No license, express or implied, by estoppel or otherwise, to any intellectual property rights is granted by this document or by any conduct of Vishay.

The products shown herein are not designed for use in medical, life-saving, or life-sustaining applications unless otherwise expressly indicated. Customers using or selling Vishay products not expressly indicated for use in such applications do so entirely at their own risk and agree to fully indemnify Vishay for any damages arising or resulting from such use or sale. Please contact authorized Vishay personnel to obtain written terms and conditions regarding products designed for such applications.

Product names and markings noted herein may be trademarks of their respective owners.