

High Power International Transformers



Greater Performance in Less Space and Weight



Constructed on a concentric platform, Signal's HPI series provides reinforced insulation while maintaining superior volumetric efficiency.

General Specifications

- Power - 1250, 1500, 1750, 2000, 2750 and 3500 VA ratings
- Dielectric Strength - 4.0Kv
- Available Input Voltage - 100V, 115V, 215V, 230V, 50/60Hz
- Output Voltage - 115/230V
- Touch-Safe terminals (IP20 type) offer a screw/binding clamp for hard wiring and a 3/16" & 1/4" Fast-On connection.
- Leakage Current @ <50 micro Amps
- Insulation System - UL Recognized Class H (180° C)
- Flammability Rating - UL 94-V0

Agency Certifications

- UL recognized to UL 506 / UL 5085-2, File # E63829, meets UL60601-1 construction
- CSA certified to C22.2 #66.1, File # 221070
- UL Insulation Systems 1446, E66312
- IEC / EN Standards IEC / EN 61558, VDE 0550, License # 2994
- TUV Rheinland Certified IEC / EN 60950, License # R9373110.2
- CE Compliance VDE Declaration of Conformity 73/23/EEC

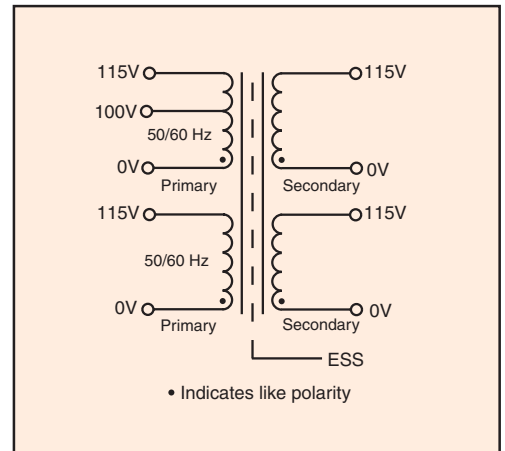
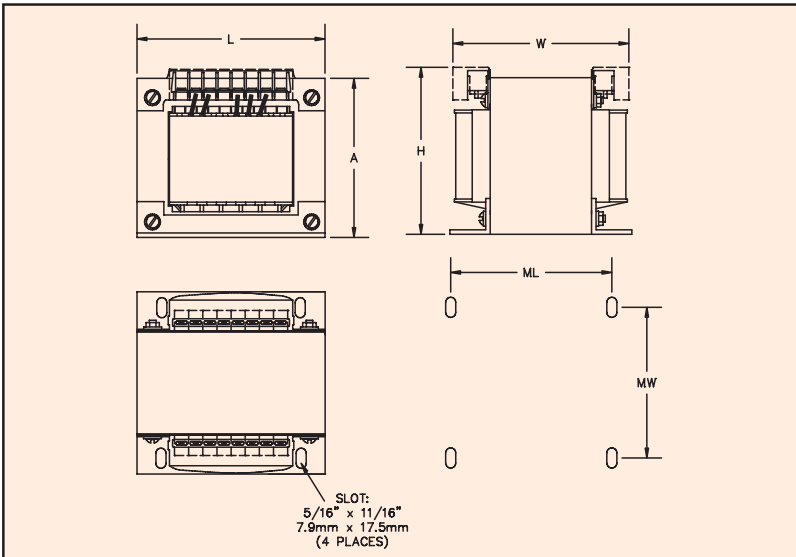

Part Number	Mechanical Dimensions						
	L	W	H	A	ML	MW	Weight
	Inches (mm)						lbs (kg)
HPI-12*	7.06 (179.3)	5.1 (129.6)	6.10 (154.9)	6.03 (153.2)	5.50 (139.7)	3.69 (93.7)	31.0 (14.07)
HPI-15*	7.06 (179.3)	5.5 (139.7)	6.10 (154.9)	6.03 (153.2)	5.50 (139.7)	4.03 (103.0)	35.75 (16.23)
HPI-17*	7.06 (179.3)	5.89 (149.7)	6.10 (154.9)	6.03 (153.2)	5.50 (139.7)	4.48 (113.3)	38.50 (17.50)
HPI-20	7.50 (190.5)	5.26 (133.7)	6.56 (166.5)	6.25 (158.8)	5.75 (146.1)	4.35 (110.5)	40.1 (18.16)
HPI-27	7.50 (190.5)	5.89 (149.7)	6.56 (166.5)	6.25 (158.8)	5.75 (146.1)	4.98 (126.5)	48.0 (21.77)
HPI-35	7.50 (190.5)	6.99 (177.6)	6.56 (166.5)	6.25 (158.8)	5.75 (146.1)	6.08 (154.4)	62.4 (28.30)

Part Number	VA	Secondary RMS Rating	
	Size	Series	Parallel
HPI-12*	1250	230V @ 5.4A	115V @ 10.9A
HPI-15*	1500	230V @ 6.5A	115V @ 13.0A
HPI-17*	1750	230V @ 7.6A	115V @ 15.2A
HPI-20	2000	230V @ 8.7A	115V @ 17.4A
HPI-27	2750	230V @ 12.0A	115V @ 24.0A
HPI-35	3500	230V @ 15.2A	115V @ 30.4A

* All models have UL, CSA, TUV and VDE agency approvals except those marked with * which have TUV instead of VDE.

Custom versions available upon request.

©2008 Signal Transformer — Specification subject to change without notice. 07.08



500 Bayview Avenue, Inwood, NY 11096
 Toll Free 866-239-5777 • Tel 516-239-5777 • Fax 516-239-7208
 sales@signaltransformer.com • techhelp@signaltransformer.com