

Fully Sealed Potentiometer Military and Professional Grade

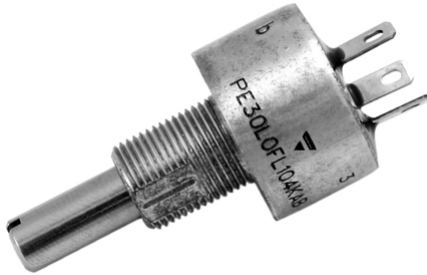

FEATURES

- High power rating 3 W at 70 °C
- Low temperature coefficient (150 ppm/°C typical)
- Cermet element
- Full sealing
- Use of faston 2.86 connections
- Tests according to CECC 41000 or IEC 60393-1
- Wires and connectors available
- Custom design on request
- Center detent option
- Material categorization: For definitions of compliance please see www.vishay.com/doc?99912



**RoHS
COMPLIANT**

DIMENSIONS in millimeters (inches) ± 0.5 mm (± 0.02")

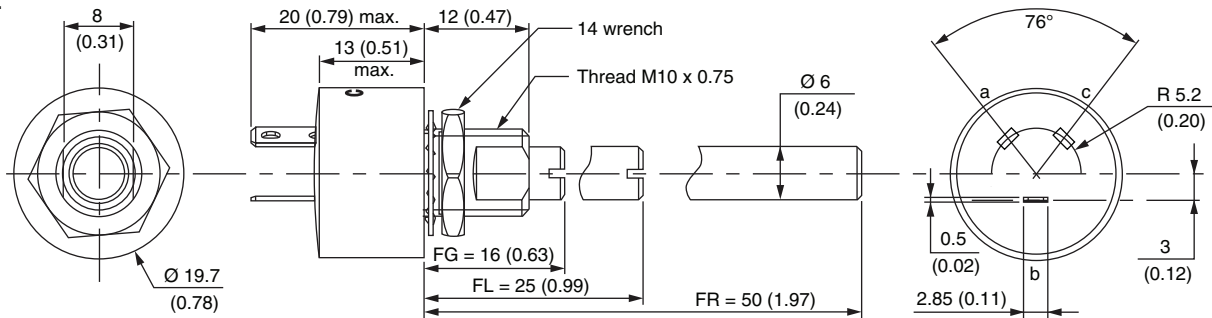
PE30L

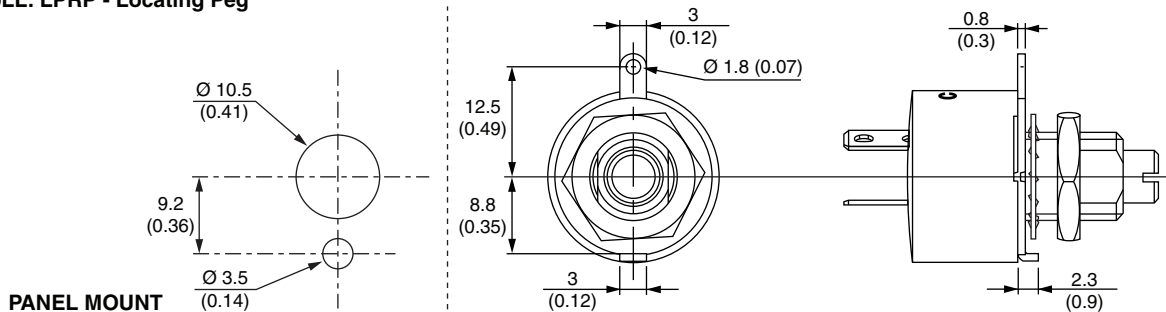

PE30LL: LPRP - Locating Peg



PE30ME: Panel Sealed

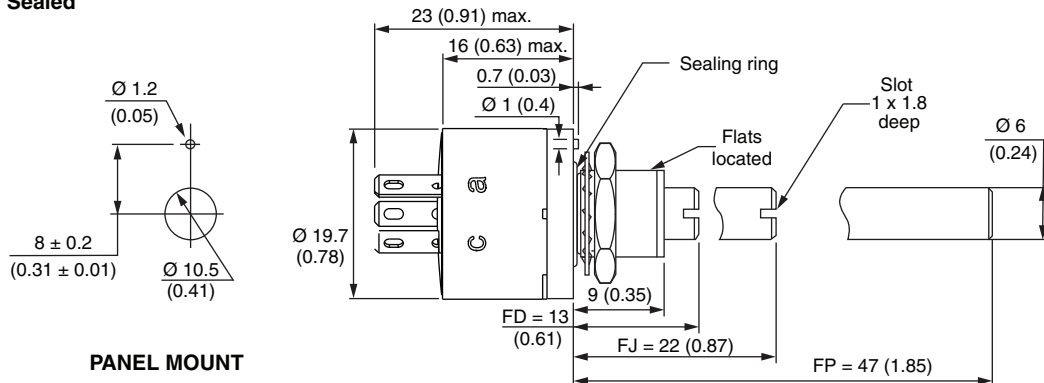

ELECTRICAL SPECIFICATIONS	
Resistive Element	Cermet
Electrical Travel	270° ± 10°
Resistance Range	Linear Taper 22 Ω to 10 MΩ
	Logarithmic Taper 100 Ω to 2.2 MΩ
Standard Series E3	1 - 2.2 - 4.7 and on request 1 - 2 - 5
Tolerance	Standard ± 20 %
	On Request ± 10 % to ± 5 %
Taper	
Power Rating	Linear 3 W at 70 °C
	Logarithmic 1.5 W at 70 °C
Circuit Diagram	
Temperature Coefficient (Typical)	± 150 ppm/°C
Limiting Element Voltage	300 V
Contact Resistance Variation (Typical)	3 % R _n or 3 Ω
End Resistance (Typical)	1 Ω
Dielectric Strength (RMS)	2500 V
Insulation Resistance (300 V _{DC})	10 ⁵ MΩ
Independent Linearity (Typical)	± 5 %



STANDARD RESISTANCE ELEMENT DATA						
STANDARD RESISTANCE VALUES	LINEAR TAPER			LOGS TAPER		
	MAX. POWER AT 70 °C	MAX. WORKING VOLTAGE	MAX. CUR. THROUGH WIPER	MAX. POWER AT 70 °C	MAX. WORKING VOLTAGE	MAX. CUR. THROUGH WIPER
Ω	W	V	mA	W	V	mA
22	3	8.1	369			
47	3	11.9	252			
100	3	17.3	173	1.5	12.2	122
220	3	25.7	116	1.5	18.2	82.6
470	3	37.5	79	1.5	26.6	56.6
1K	3	54.8	54	1.5	38.7	38.7
2.2K	3	81.2	37	1.5	57.4	26.1
4.7K	3	119.9	25	1.5	83.9	17.9
10K	3	173	17	1.5	122	12.2
22K	3	257.7	11	1.5	181.6	8.25
47K	1.91	300	6.3	1.5	265	5.64
100K	0.90	300	3	0.9	300	3
220K	0.41	300	1.36	0.41	300	1.36
470K	0.19	300	0.63	0.19	300	0.63
1M	0.09	300	0.30	0.09	300	0.30
2.2M	0.04	300	0.13	0.04	300	0.13
4.7M	0.02	300	0.06			
10M	0.01	300	0.03			

MECHANICAL SPECIFICATIONS		
Mechanical Travel	300° ± 5°	
Operating Torque (Typical)	3 Ncm max.	4.25 oz.-inch max.
End Stop Torque	120 Ncm max.	10.51 lb oz.-inch max.
Tightening Torque of Mounting Nut	250 Ncm max.	22 lb-inch max.
Unit Weight	23 to 32 g max.	0.8 to 1.13 oz.
Terminals	e3: Pure Sn	

ENVIRONMENTAL SPECIFICATIONS	
Temperature Range	- 55 °C to 125 °C
Climatic Category	55/125/56
Sealing	Fully sealed - Container IP67

OPTIONS	
Special Feature Command Shaft	Length is measured from the mounting surface to the free end of the shaft. The screwdriver slot is aligned with the wiper within ± 10°. Special shafts are available, in accordance to drawings supplied by customers. We recommend that customers should not machine tool shafts, in order to avoid damage. Bending or torsion of terminals should also be avoided.
Panel Sealing (PE30M)	The panel sealing device consists of a ring located in a groove on the potentiometer face. Sealing is obtained by tightening the ring against the panel when mounting the potentiometer. Old code: PE30P

OPTIONS	
Locating Peg (PE30LL)	Location is obtained by fitting a special washer on the mounting face of the potentiometer. Old code: LPRP
Shaft Locking (PE30LD)	<p>The shaft locking device consists of a tapered nut tightening a slotted notched washer against both bushing and shaft. DBAN tightening torque is 200 Ncm, shaft locking torque being 30 Ncm. DBAN is also available with all special types. This device is normally supplied in a separate bag. Can be pre-mounted on request.</p> <p>Assembling Method</p>

CENTER DETENT
<ul style="list-style-type: none"> Stable position in mid mechanical travel Output ratio 50 % ± 10 % Rotational life: 10 000 actuations
ORDERING INFORMATION (First order only)
CV1M

MARKING
<ul style="list-style-type: none"> Vishay trademark Part number (including ohmic value and tolerance code) Manufacturing date code Marking of terminals 3, and a, b, c

PERFORMANCES				
TESTS	CONDITIONS	TYPICAL VALUES AND DRIFTS		
		$\Delta R_T/R_T$ (%)	$\Delta R_{1-2}/R_{1-2}$ (%)	OTHER
Electrical Endurance	1000 h at rated power 90°/30° - ambient temp. 70 °C	± 1 %	-	Contact res. variation: < 3 % R _n
Climatic Sequence	Phase A dry heat 125 °C Phase B damp heat Phase C cold - 55 °C Phase D damp heat 5 cycles	± 0.5 %	± 1 %	-
Damp Heat, Steady State	56 days 40 °C 93 % HR	± 0.5 %	± 1 %	Insulation resistance: > 10 ⁴ MΩ
Change of Temperature	5 cycles - 55 °C at + 125 °C	± 0.5 %	-	-
Mechanical Endurance	25 000 cycles	± 3 %	-	Contact res. variation: < 2 % R _n
Shock	50 g's at 11 ms 3 successive shocks in 3 directions	± 0.1 %	± 0.2 %	-
Vibration	10 Hz to 55 Hz 0.75 mm or 10 g's during 6 h	± 0.1 %	± 0.2 %	-



Fully Sealed Potentiometer
Military and Professional Grade

Vishay Sfernice

ORDERING INFORMATION (Part Number)																	
P	E	3	0	L	B	F	G	2	0	4	M	A	B				
MODEL	BUSHING	OPTION	SHAFT			OHMIC VALUE	TOLERANCE	TAPER	PACKAGING	SPECIAL NUMBER							
PE30	L = M10 x 0.75 M = Panel sealed M10 x 0.75	0 = none For L bushing D = DBAN L = LPRP B = DBAN and LPRP For M bushing E = Peg A = Peg and DBAN	For L bushing (= old codes): FG 16 mm, slotted = AC FL 25 mm, slotted = AM FR 50 mm, plain = AL For M bushing FD = 13 mm, slotted = AC FJ = 22 mm, slotted = AM FP = 47 mm, plain = AL			A law = from 22 Ω to 10 MΩ L and F laws = from 100 Ω to 2.2 MΩ	± 20 % On request: ± 10 % ± 5 %	A = Linear L = Clockwise logarithmic F = Clockwise inverse logarithmic	B = Box of 10 pieces	(if applicable) Given by Vishay for custom design or E105 CV1M							

PART NUMBER DESCRIPTION (for information only)													
PE30		LPRP	AC	200K	20 %	A	DBAN		CV1M	BO			e3
MODEL	FEATURES	OPTION	SHAFT	VALUE	TOL.	TAPER	OPTION	SPECIAL	DETENT	PACKAGING	CUSTOM SHAFT	SPECIAL	LEAD (Pb)-FREE



Disclaimer

ALL PRODUCT, PRODUCT SPECIFICATIONS AND DATA ARE SUBJECT TO CHANGE WITHOUT NOTICE TO IMPROVE RELIABILITY, FUNCTION OR DESIGN OR OTHERWISE.

Vishay Intertechnology, Inc., its affiliates, agents, and employees, and all persons acting on its or their behalf (collectively, "Vishay"), disclaim any and all liability for any errors, inaccuracies or incompleteness contained in any datasheet or in any other disclosure relating to any product.

Vishay makes no warranty, representation or guarantee regarding the suitability of the products for any particular purpose or the continuing production of any product. To the maximum extent permitted by applicable law, Vishay disclaims (i) any and all liability arising out of the application or use of any product, (ii) any and all liability, including without limitation special, consequential or incidental damages, and (iii) any and all implied warranties, including warranties of fitness for particular purpose, non-infringement and merchantability.

Statements regarding the suitability of products for certain types of applications are based on Vishay's knowledge of typical requirements that are often placed on Vishay products in generic applications. Such statements are not binding statements about the suitability of products for a particular application. It is the customer's responsibility to validate that a particular product with the properties described in the product specification is suitable for use in a particular application. Parameters provided in datasheets and/or specifications may vary in different applications and performance may vary over time. All operating parameters, including typical parameters, must be validated for each customer application by the customer's technical experts. Product specifications do not expand or otherwise modify Vishay's terms and conditions of purchase, including but not limited to the warranty expressed therein.

Except as expressly indicated in writing, Vishay products are not designed for use in medical, life-saving, or life-sustaining applications or for any other application in which the failure of the Vishay product could result in personal injury or death. Customers using or selling Vishay products not expressly indicated for use in such applications do so at their own risk and agree to fully indemnify and hold Vishay and its distributors harmless from and against any and all claims, liabilities, expenses and damages arising or resulting in connection with such use or sale, including attorneys fees, even if such claim alleges that Vishay or its distributor was negligent regarding the design or manufacture of the part. Please contact authorized Vishay personnel to obtain written terms and conditions regarding products designed for such applications.

No license, express or implied, by estoppel or otherwise, to any intellectual property rights is granted by this document or by any conduct of Vishay. Product names and markings noted herein may be trademarks of their respective owners.

Material Category Policy

Vishay Intertechnology, Inc. hereby certifies that all its products that are identified as RoHS-Compliant fulfill the definitions and restrictions defined under Directive 2011/65/EU of The European Parliament and of the Council of June 8, 2011 on the restriction of the use of certain hazardous substances in electrical and electronic equipment (EEE) - recast, unless otherwise specified as non-compliant.

Please note that some Vishay documentation may still make reference to RoHS Directive 2002/95/EC. We confirm that all the products identified as being compliant to Directive 2002/95/EC conform to Directive 2011/65/EU.