



AK5355

Low Power 16bit $\Delta\Sigma$ ADC

FEATURES

The AK5355 is a low voltage 16bit A/D converter for digital audio systems. The AK5355 also includes an Input Gain Amplifier, making it suitable for microphone applications or low-input signal levels. The analog signal input of the AK5355 is single-ended, eliminating the need for external filters. The AK5355 is housed in a space-saving 16pin TSSOP or 20pin QFN package.

FEATURES

1. Resolution: 16bits
2. Recording Functions
 - Gain Amplifier (0dB / +15dB)
 - Digital HPF for DC-offset cancellation ($f_c=3.4\text{Hz}@f_s=44.1\text{kHz}$)
3. ADC Characteristics
 - Single-ended Input
 - Input Level: $1.8\text{Vpp}@V_A=3.0\text{V}$ (= 0.6 x V_A)
 - S/(N+D): 85dB
 - DR, S/N: 91dB
4. Master Clock: 256fs/384fs/512fs
5. Audio Data Format: MSB First, 2's compliment
 - 16bit MSB justified or I²S
8. Power Supply
 - V_A, V_D : 2.1 ~ 3.6V (typ. 3.0V)
9. Power Supply Current: 5mA
10. T_a = -40 ~ 85°C
11. Package: 16pin TSSOP
20pin QFN (4.2mm x 4.2mm, 0.5mm pitch)

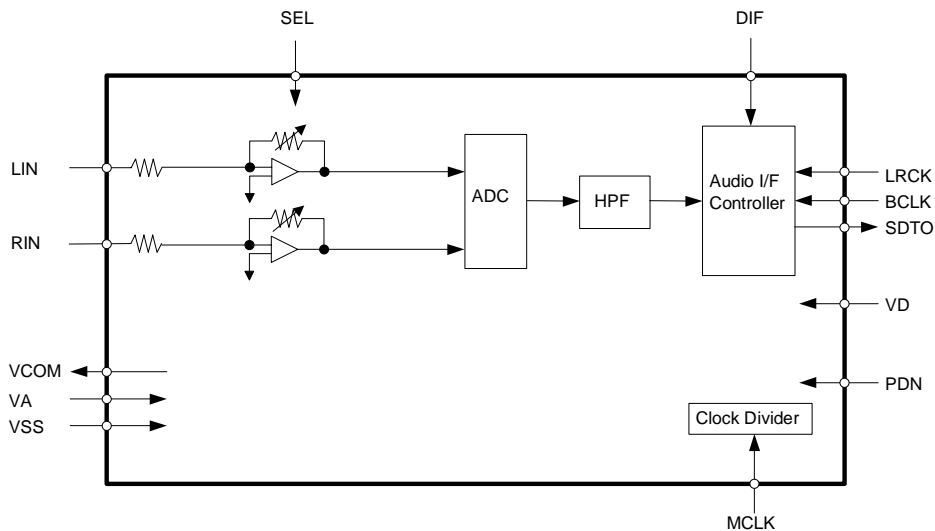

■ Ordering Guide

AK5355VT	-40 ~ +85°C	16pin TSSOP (0.65mm pitch)
AK5355VN	-40 ~ +85°C	20pin QFN (0.5mm pitch)
AKD5355	Evaluation Board for AK5355VT	

■ Pin Layout (AK5355VT)

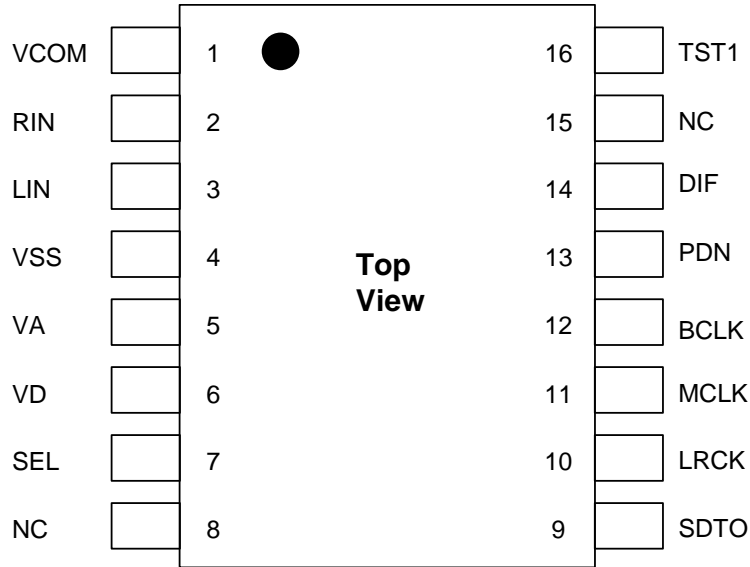

■ Pin Layout (AK5355VN)

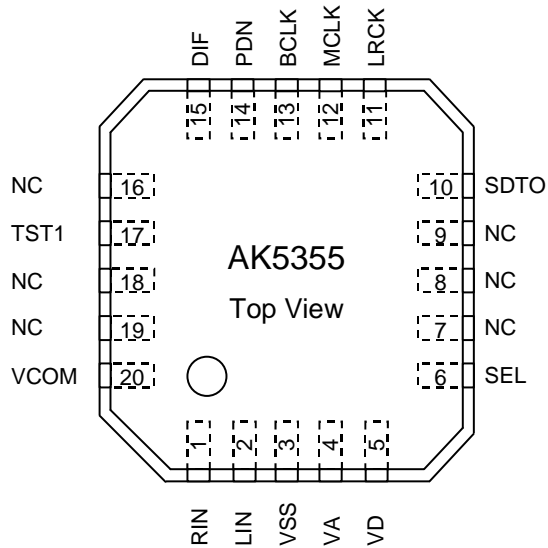

PIN/FUNCTION (AK5355VT)

No.	Pin Name	I/O	Function
1	VCOM	O	ADC Common Voltage Output Pin
2	RIN	I	Rch Input Pin
3	LIN	I	Lch Input Pin
4	VSS	-	Ground Pin
5	VA	-	Analog Power Supply Pin, +3.0V
6	VD	-	Digital Power Supply Pin, +3.0V
7	SEL	I	Input Gain Select Pin “L”: 0dB, “H”: +15dB
8	NC	-	NC Pin (No internal bonding)
9	SDTO	O	Audio Serial Data Output Pin
10	LRCK	I	Input/Output Channel Clock Pin
11	MCLK	I	Master Clock Input Pin
12	BCLK	I	Audio Serial Data Clock Pin
13	PDN	I	Reset & Power Down Pin “L” : Reset & Power down, “H” : Normal operation
14	DIF	I	Audio Data Format Select Pin “L”: MSB justified, “H”: I ² S
15	NC	-	NC Pin (No internal bonding)
16	TST1	I	TEST pin (Pull-down Pin) This pin should be left floating or connected to VSS

Note: All digital input pins should not be left floating.

PIN/FUNCTION (AK5355VN)

No.	Pin Name	I/O	Function
1	RIN	I	Rch Input Pin
2	LIN	I	Lch Input Pin
3	VSS	-	Ground Pin
4	VA	-	Analog Power Supply Pin, +3.0V
5	VD	-	Digital Power Supply Pin, +3.0V
6	SEL	I	Input Gain Select Pin “L”: 0dB, “H”: +15dB
7	NC	-	NC Pin (No internal bonding) This pin should be left floating.
8	NC	-	NC Pin (No internal bonding) This pin should be left floating.
9	NC	-	NC Pin (No internal bonding) This pin should be left floating.
10	SDTO	O	Audio Serial Data Output Pin
11	LRCK	I	Input/Output Channel Clock Pin
12	MCLK	I	Master Clock Input Pin
13	BCLK	I	Audio Serial Data Clock Pin
14	PDN	I	Reset & Power Down Pin “L”: Reset & Power down, “H”: Normal operation
15	DIF	I	Audio Data Format Select Pin “L”: MSB justified, “H”: I ² S
16	NC	-	NC Pin (No internal bonding) This pin should be left floating.
17	TST1	I	TEST pin (Pull-down Pin) This pin should be left floating or connected to VSS
18	NC	-	NC Pin (No internal bonding) This pin should be left floating.
19	NC	-	NC Pin (No internal bonding) This pin should be left floating.
20	VCOM	O	ADC Common Voltage Output Pin

Note: All digital input pins should not be left floating.

ABSOLUTE MAXIMUM RATINGS

(VSS=0V; Note 1)

Parameter		Symbol	Min	max	Units
Power Supply	Analog	VA	-0.3	4.6	V
	Digital	VD	-0.3	4.6	V
Input Current (Any Pin Except Supplies)		IIN	-	±10	mA
Analog Input Voltage (LIN, RIN pins)		VINA	-0.3	VA+0.3	V
Digital Input Voltage		VIND	-0.3	VD+0.3	V
Ambient Temperature (power applied)		Ta	-40	85	°C
Storage Temperature		Tstg	-65	150	°C

Note 1. All voltages with respect to ground.

WARNING: Operation at or beyond these limits may results in permanent damage to the device.
Normal operation is not guaranteed at these extremes.

RECOMMENDED OPERATING CONDITIONS

(VSS=0V; Note 1)

Parameter		Symbol	min	typ	max	Units
Power Supply	Analog (VA pin)	VA	2.1	3.0	3.6	V
	Digital (VD pin)	VD	2.1	3.0	VA	V

Note 1. All voltages with respect to ground.

WARNING: AKM assumes no responsibility for the usage beyond the conditions in this data sheet.

ANALOG CHARACTERISTICS

(Ta=25°C; VA, VD=3.0V; fs=44.1kHz; Signal Frequency=1kHz; Measurement frequency=10Hz ~ 20kHz; unless otherwise specified)

Parameter	min	typ	max	Units	
Resolution			16	bits	
Input PGA Characteristics (IPGA):					
Input Voltage (Note 2)	Gain = 0dB	1.65	1.8	1.95	Vpp
	Gain = +15dB	0.29	0.32	0.35	Vpp
Input Impedance	Gain = 0dB	27	40		kΩ
	Gain = +15dB	20	30		kΩ
ADC Analog Input Characteristics: (Note 3)					
S/(N+D) (-0.5dBFS Output)	Gain = 0dB	75	85		dB
	Gain = +15dB	70	80		dB
D-Range (-60dBFS Output, A-weight)	Gain = 0dB	84	91		dB
	Gain = +15dB	76	84		dB
S/N (A-weight)	Gain = 0dB	84	91		dB
	Gain = +15dB	76	84		dB
Interchannel Isolation	Gain = 0dB	90	100		dB
	Gain = +15dB	80	90		dB
Interchannel Gain Mismatch	Gain = 0dB		0.2	0.5	dB
	Gain = +15dB		0.2	1.0	dB
Power Supplies					
Power Supply Current: VA+VD					
Normal Operation (PDN="H")			5	7.5	mA
Power Down (PDN="L") (Note 4)	AK5355VT		10	100	μA
	AK5355VN		10	20	μA

Note 2. Analog input voltage (full-scale voltage) scales with VA.

Gain = 0dB; 0.6 x VA

Gain = +15dB; 0.107 x VA

Note 3. ADC measurements are input from LIN/RIN and routed through input gain amplifier.

The internal HPF cancels the offset of input gain amplifier and ADC.

Note 4. In case of power-down mode, all digital input pins including clocks pins (MCLK, BCLK and LRCK) are held at VD or VSS. PDN pin is held at VSS.

FILTER CHARACTERISTICS

(Ta=25°C; VA, VD=2.1 ~ 3.6V; fs=44.1kHz)

Parameter	Symbol	min	typ	max	Units	
ADC Digital Filter (Decimation LPF):						
Passband (Note 5)	±0.1dB -1.0dB -3.0dB	PB	0	17.4	kHz	
					20.0	kHz
					21.1	kHz
Stopband (Note 5)	SB	27.0			kHz	
Passband Ripple	PR			±0.1	dB	
Stopband Attenuation	SA	65			dB	
Group Delay (Note 6)	GD		17.0		1/fs	
Group Delay Distortion	ΔGD		0		μs	
ADC Digital Filter (HPF):						
Frequency Response (Note 5)	-3dB -0.5dB -0.1dB	FR		3.4	Hz	
					10	Hz
					22	Hz

Note 5. The passband and stopband frequencies scale with fs (sampling frequency).

For examples, PB=0.454 x fs (@ADC: -1.0dB).

Note 6. The calculated delay time caused by digital filtering. This time is from the input of an analog signal to setting the 16bit data of both channels to the output register of the ADC and includes the group delay of the HPF.

DC CHARACTERISTICS

(Ta=25°C; VA, VD=2.1 ~ 3.6V)

Parameter	Symbol	min	typ	max	Units
High-Level Input Voltage (Except for TST1 pin)	VIH	75%VD	-	-	V
Low-Level Input Voltage (Except for TST1 pin)	VIL	-	-	25%VD	V
High-Level Output Voltage (Iout=-80μA)	VOH	VD-0.4	-	-	V
Low-Level Output Voltage (Iout=80μA)	VOL	-	-	0.4	V
Input Leakage Current (Note 7)	Iin	-	-	± 10	μA

Note 7. TST1 pin is pulled-down internally (typ. 100kΩ)

SWITCHING CHARACTERISTICS

(Ta=25°C; VA, VD=2.1 ~ 3.6V; CL=20pF)

Parameter	Symbol	min	typ	max	Units
Control Clock Frequency					
Master Clock (MCLK)					
256fs: Frequency	fCLK	2.048	11.2896	12.8	MHz
Pulse Width Low	tCLKL	28			ns
Pulse Width High	tCLKH	28			ns
384fs: Frequency	fCLK	3.072	16.9344	19.2	MHz
Pulse Width Low	tCLKL	23			ns
Pulse Width High	tCLKH	23			ns
512fs: Frequency	fCLK	4.096	22.5792	25.6	MHz
Pulse Width Low	tCLKL	16			ns
Pulse Width High	tCLKH	16			ns
Channel Clock (LRCK) Frequency	fs	8	44.1	50	kHz
Duty Cycle	duty	45		55	%
Audio Interface Timing					
BCLK Period	tBLK	312.5			ns
BCLK Pulse Width Low	tBLKL	130			ns
Pulse Width High	tBLKH	130			ns
BCLK “↓” to LRCK	tBLR	-tBLKH+50		tBLKL-50	ns
LRCK Edge to SDTO (MSB)	tDLR			80	ns
BCLK “↓” to SDTO	tDSS			80	ns
Reset / Initializing Timing					
PDN Pulse Width	tPW	150			ns
PDN “↑” to SDTO (Note 8)	tPWV		4128		1/fs

Note 8. This is the number of LRCK rising after the PDN pin is pulled high.

■ Timing Diagram

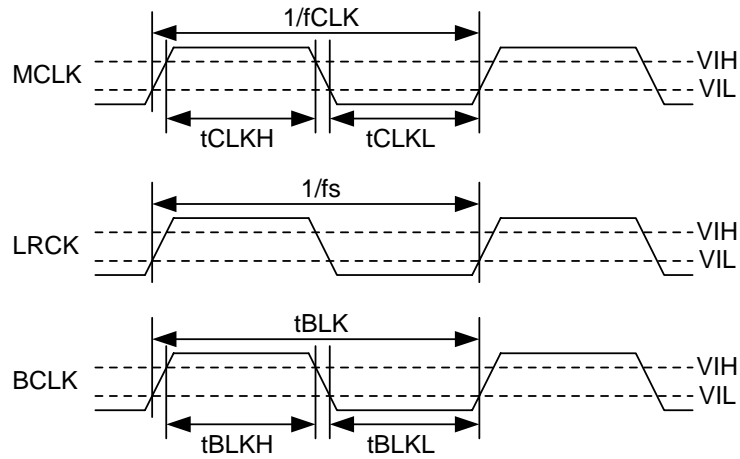

Figure 1. Clock Timing

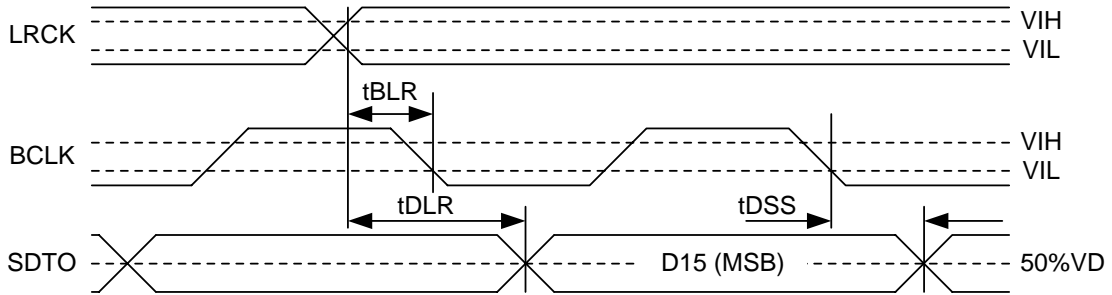

Figure 2. Audio Data Input/Output Timing (Audio I/F = No.0)

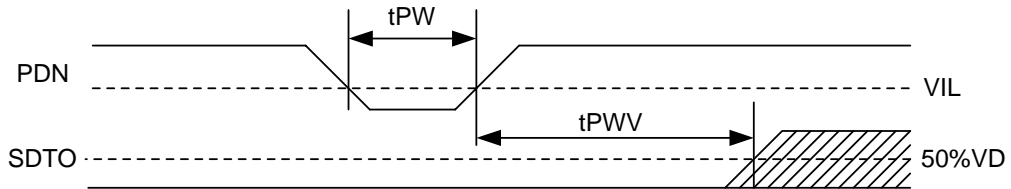

Figure 3. Reset Timing

OPERATION OVERVIEW

■ **System Clock**

The clocks required to operate are MCLK (256fs/384fs/512fs), LRCK (fs) and BCLK (32fs~). The master clock (MCLK) should be synchronized with LRCK. The phase between these clocks does not matter. The frequency of MCLK can be input as 256fs, 384fs or 512fs. When the 384fs or 512fs is input, the internal master clock is divided into 2/3 or 1/2 automatically.

*fs is sampling frequency.

All external clocks (MCLK, BCLK and LRCK) should always be present whenever the ADC is in operation. If these clocks are not provided, the AK5355 may draw excess current and will not operate properly because it utilizes these clocks for internal dynamic refresh of registers. If the external clocks are not present, the AK5355 should be placed in power-down mode.

■ **Audio Data I/F Format**

The SDTO, BCLK and LRCK pins are connected to an external controller. The audio data format has two modes, MSB-first and 2's compliment. The data format is set using the DIF pin.

No.	DIF pin	SDTO (ADC)	LRCK	BCLK	Figure
0	L	16bit MSB justified	Lch: "H", Rch: "L"	≥ 32fs	Figure 4
1	H	I ² S Compatible	Lch: "L", Rch: "H"	≥ 32fs	Figure 5

Table 1. Audio Data Format

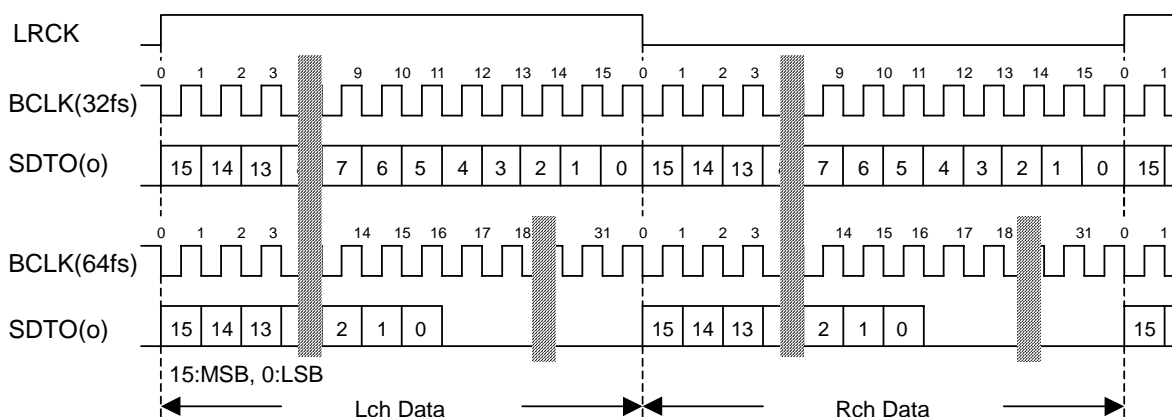

Figure 4. Audio Data Timing (No.0)

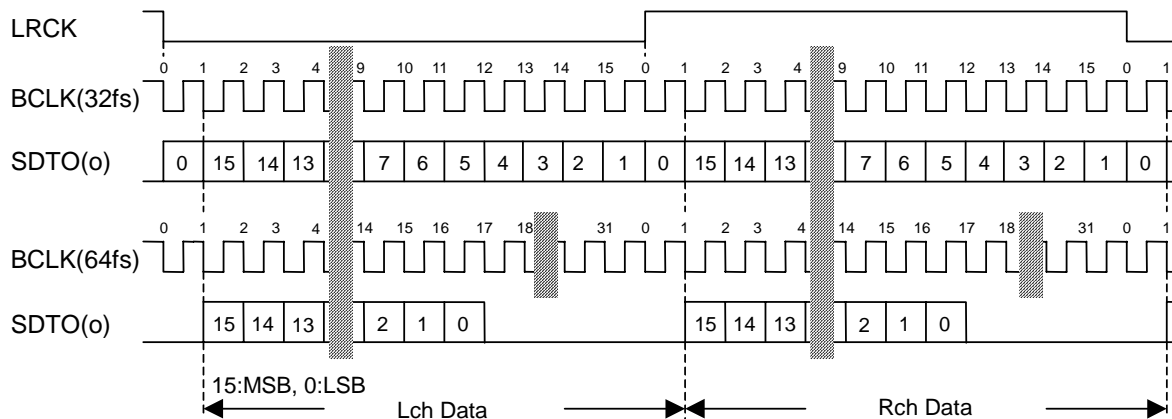

Figure 5. Audio Data Timing (No. 1)

■ Digital High Pass Filter

The AK5355 has a Digital High Pass Filter (HPF) to cancel DC-offset in both the ADC and input gain amplifier. The cut-off frequency of the HPF is 3.4Hz at fs=44.1kHz. This cut-off frequency scales with the sampling frequency (fs).

■ Input Gain Amplifier

The AK5355 includes an input gain amplifier. The gain can be changed to 0dB or +15dB by using the SEL pin. Input impedance is 40kΩ typically.

SEL pin	Gain
L	0dB
H	+15dB

Table 2. Input Gain Amplifier

■ Power down

The AK5355 is placed in the power-down mode by bringing PDN "L". The digital filter is also reset at the same time. This reset should always be done after power-up. An analog initialization cycle starts after exiting the power-down mode. The output data SDTO becomes available after 4128 cycles of LRCK clock. During initialization, the ADC digital data outputs of both channels are forced to a 2's complement "0". The ADC outputs settle to the data corresponding to the input signals at the end of initialization (Settling time equals the group delay time approximately).

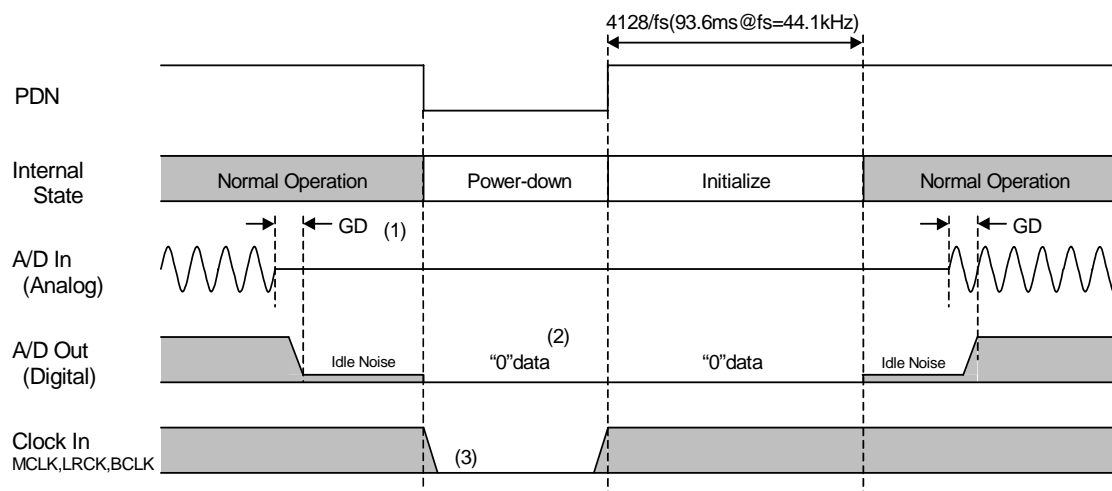

Notes:

- (1) Digital output corresponding to the analog input is delayed by the Group Delay amount (GD).
- (2) A/D output is "0" data in the power-down state.
- (3) When the external clocks (MCLK, BCLK and LRCK) are stopped, the AK5355 should be placed in the power-down state.

Figure 6. Power-down/up sequence example

■ System Reset

The AK5355 should be reset once by bringing PDN "L" upon power-up. The AK5355 is powered up and the internal timing starts clocking by LRCK "↑" after exiting reset and power down state by MCLK. The AK5355 is in the power-down mode until MCLK and LRCK are input.

SYSTEM DESIGN (AK5355VT)

Figure 7 shows the system connection diagram. An evaluation board [AKD5355] is available which demonstrates the application circuit, optimum layout, power supply arrangements and measurement results.

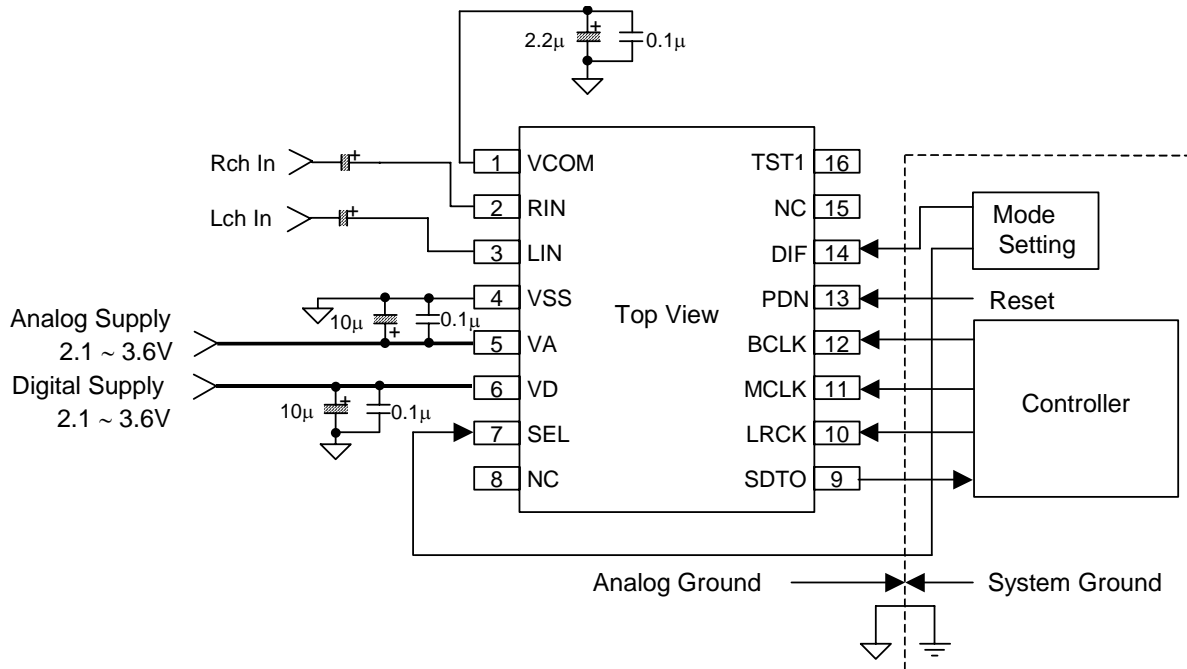

Figure 7. System Connection Diagram Example (AK5355VT)

SYSTEM DESIGN (AK5355VN)

Figure 8 shows the system connection diagram. An evaluation board [AKD5355] is available which demonstrates the application circuit, optimum layout, power supply arrangements and measurement results.

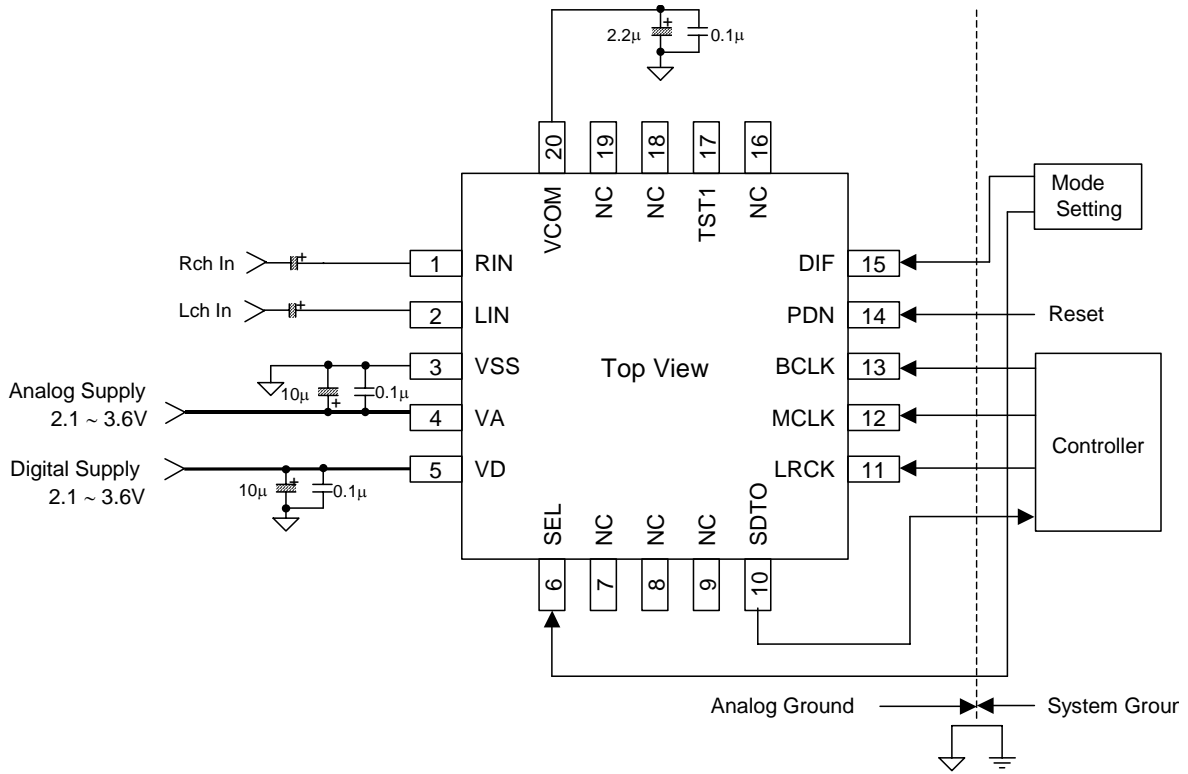

Figure 8. System Connection Diagram Example (AK5355VN)

■ MIC Device Connection Example

Figure 9 and Figure 10 show the connection example of MIC Device. In this case, a mono microphone is connected to LIN pin the AK5355. Unused RIN pin can be open. The power supply for the microphone is provided via 4.4kΩ (2.2kΩ + 2.2kΩ) from analog power supply. The power supply noise provided to the microphone should be care because the microphone gain is usually high, around 40dB. In Figure 9, 1st order LPF by 2.2kΩ and 10μF is inserted between the power supply and the microphone.

The AK5355 has a gain of +15dB in analog stage. However, as the usual application needs a gain of around 40dB or 50dB, the shortage of gain, 25dB or 35dB, should be covered by digital processing like DSP. The total S/N in each gain level is shown in Table 3

Analog Gain	Digital Gain	S/N
+15dB	0dB	83dB
+15dB	+25dB	58dB
+15dB	+35dB	48dB

Table 3. S/N of each gain level

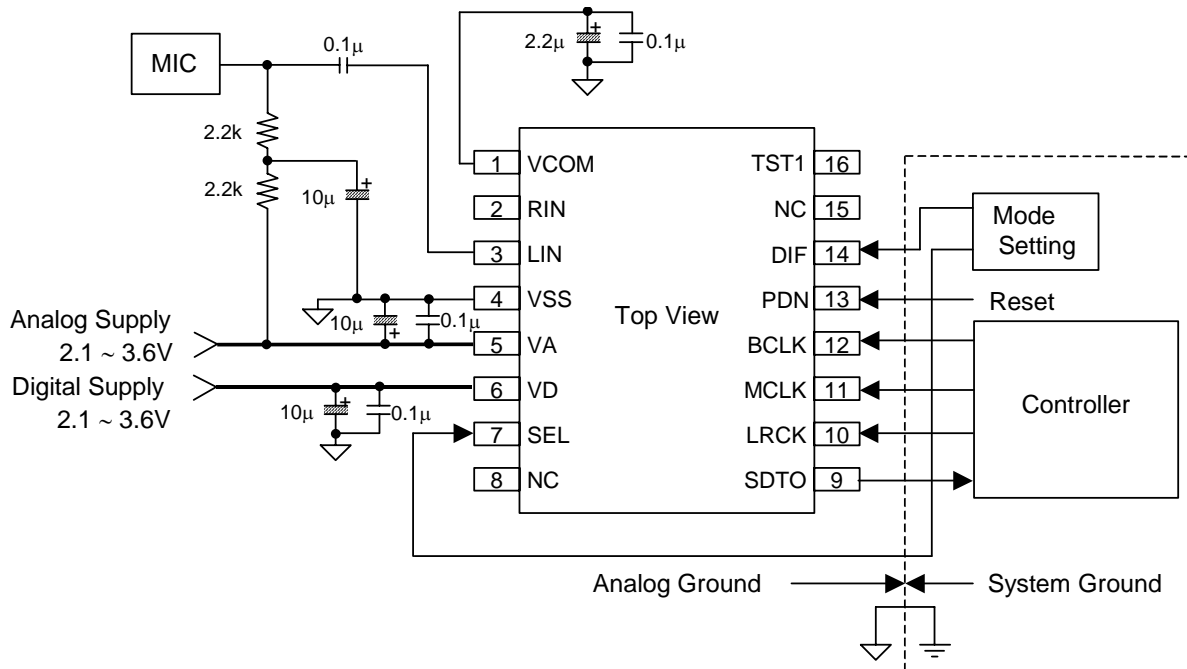

Figure 9. MIC Device Connection Example (AK5355VT)

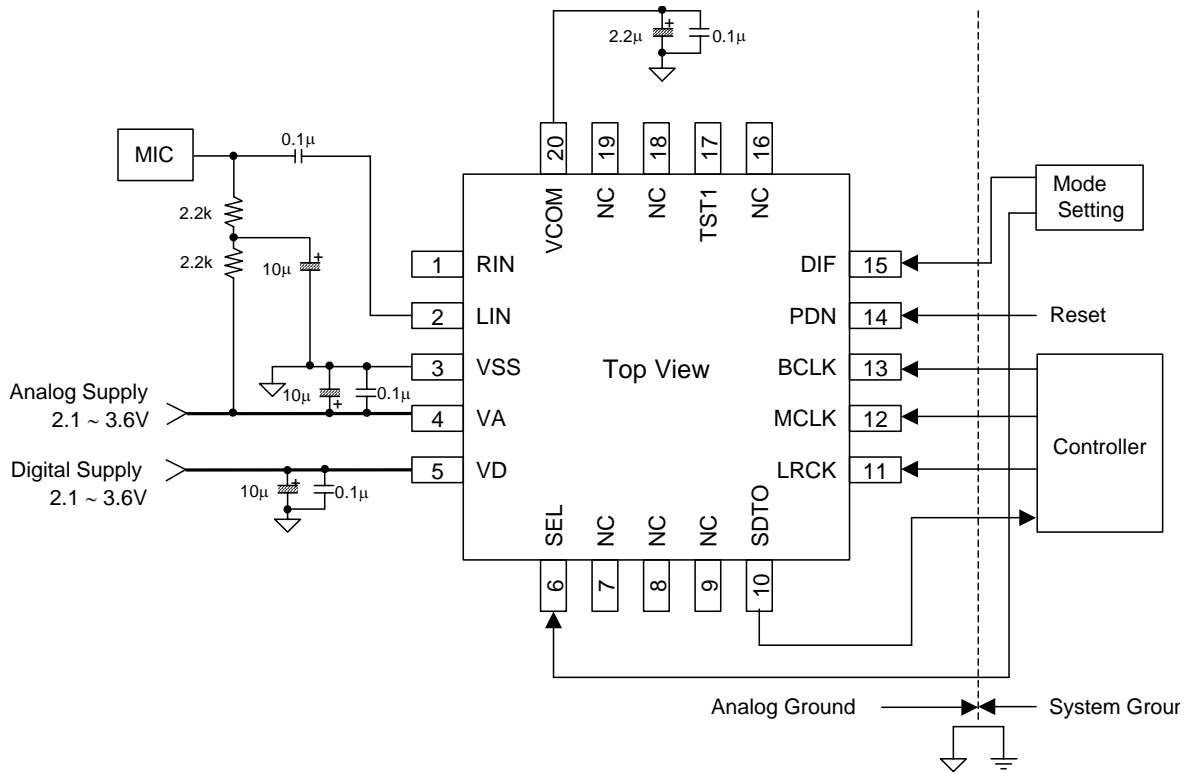

Figure 10. MIC Device Connection Example (AK5355VN)

1. Grounding and Power Supply Decoupling

The AK5355 requires careful attention to power supply and grounding arrangements. VA is usually supplied from the analog supply in the system. VD is a power supply pin to interface with the external ICs and is supplied from the digital supply in the system. VSS of the AK5355 should be connected to the analog ground plane. System analog ground and digital ground should be connected together near to where the supplies are brought onto the printed circuit board. Decoupling capacitors should be as near to the AK5355 as possible, with the small value ceramic capacitor being the nearest.

2. Voltage Reference

The input to VA Voltage sets the analog input range. A 0.1 μ F ceramic capacitor and a 10 μ F electrolytic capacitor are normally connected to VA and VSS pins. VCOM is a signal ground of this chip. An electrolytic 2.2 μ F in parallel with a 0.1 μ F ceramic capacitor attached to these pins eliminates the effects of high frequency noise. No load current may be drawn from the VCOM pin. All signals, especially clock, should be kept away from the VA, VD and VCOM pins in order to avoid unwanted coupling into the AK5355.

3. Analog Inputs

The analog inputs are single-ended and the input resistance is 40k Ω (typ). The input signal range scales with nominally $(0.6 \times VA) V_{pp}$ (typ) @ GAIN = 0dB centered around the internal common voltage (typ. $0.45 \times VA$). Usually, the input signal cuts DC with a capacitor. The cut-off frequency is $f_c = (1/2\pi RC)$. The ADC output data format is 2's complement. The DC offset including the ADC's own DC offset is removed by the internal HPF ($f_c = 3.4\text{Hz} @ f_s = 44.1\text{kHz}$).

PACKAGE (AK5355VT)

16pin TSSOP (Unit: mm)

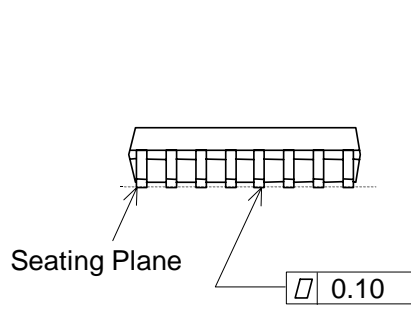
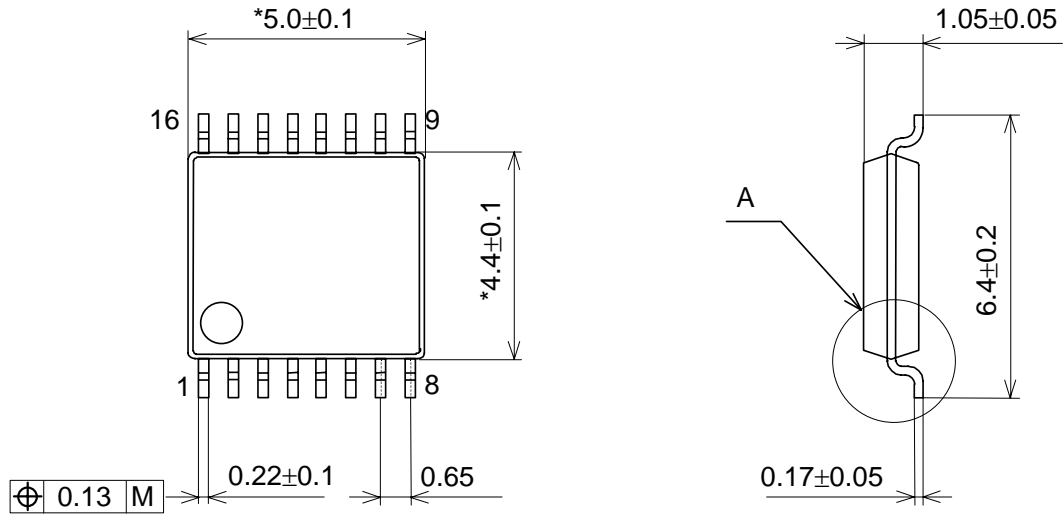

Detail A

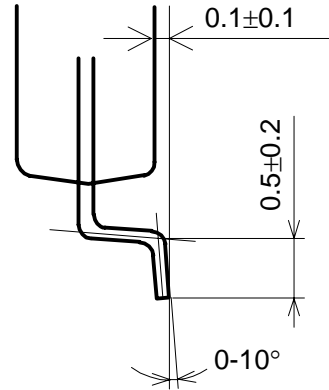

NOTE: Dimension "*" does not include mold flash.

■ Package & Lead frame material

- Package molding compound: Epoxy
- Lead frame material: Cu
- Lead frame surface treatment: Solder (Pb free) plate

PACKAGE (AK5355VN)

20pin QFN (Unit: mm)

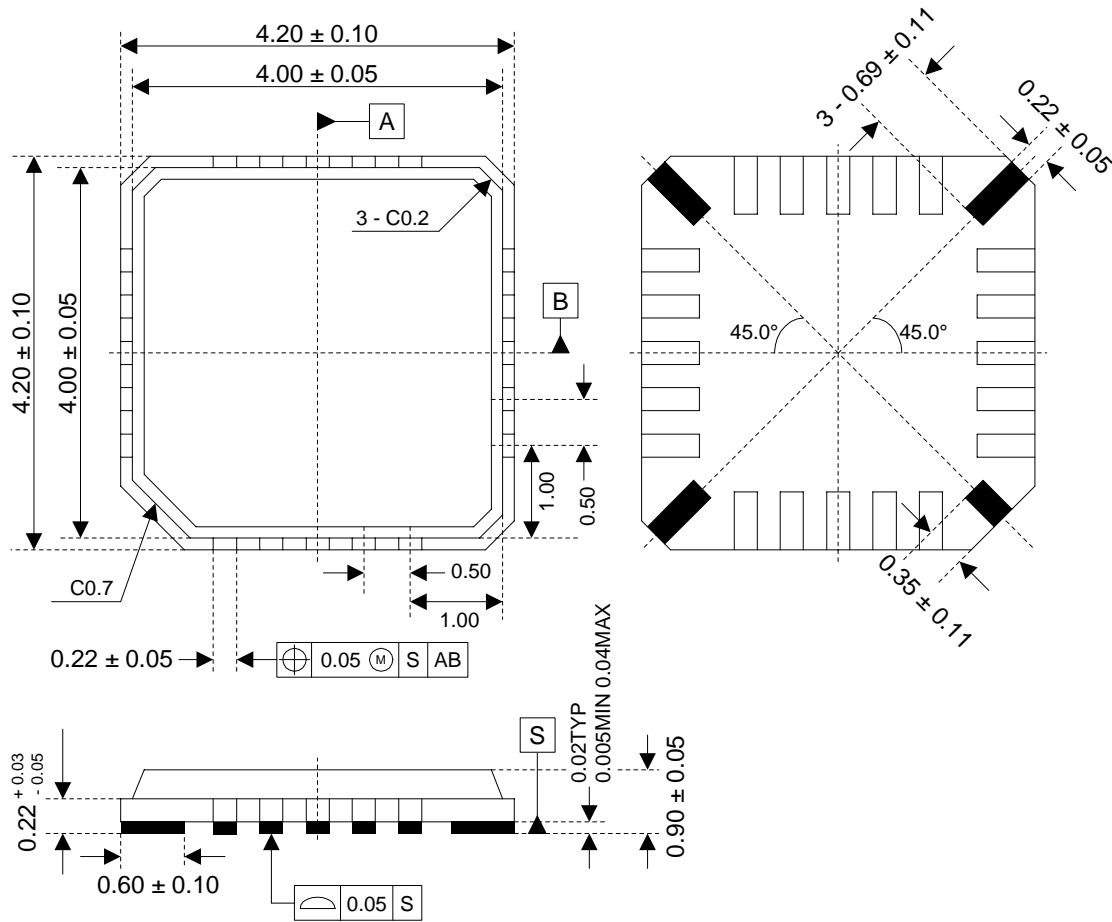

Note: The black parts of back package should be open.

■ **Package & Lead frame material**

- Package molding compound: Epoxy
- Lead frame material: Cu
- Lead frame surface treatment: Solder (Pb free) plate

MARKING (AK5355VT)

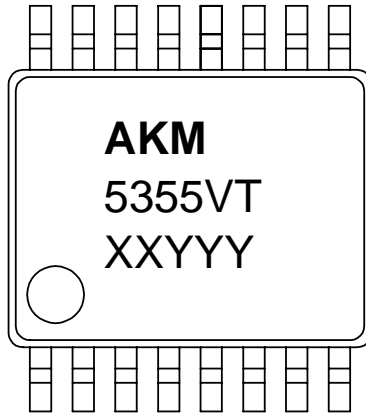

- 1) Pin #1 indication
- 2) Date Code : XXYYY (5 digits)
 - XX : Lot#
 - YYY : Date Code
- 3) Marketing Code : 5355VT
- 4) Asahi Kasei Logo

MARKING (AK5355VT)

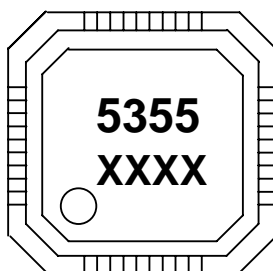

1

XXXX : Date code identifier (4 digits)

Revision History

Date (YY/MM/DD)	Revision	Reason	Page	Contents
01/08/27	00	First Edition		
05/01/20	01	Spec addition	2	20pin QFN package is added.
			6	Power supply current (Power-down mode, 20QFN): 20μA(max)

IMPORTANT NOTICE

- These products and their specifications are subject to change without notice. Before considering any use or application, consult the Asahi Kasei Microsystems Co., Ltd. (AKM) sales office or authorized distributor concerning their current status.
- AKM assumes no liability for infringement of any patent, intellectual property, or other right in the application or use of any information contained herein.
- Any export of these products, or devices or systems containing them, may require an export license or other official approval under the law and regulations of the country of export pertaining to customs and tariffs, currency exchange, or strategic materials.
- AKM products are neither intended nor authorized for use as critical components in any safety, life support, or other hazard related device or system, and AKM assumes no responsibility relating to any such use, except with the express written consent of the Representative Director of AKM. As used here:
 - a. A hazard related device or system is one designed or intended for life support or maintenance of safety or for applications in medicine, aerospace, nuclear energy, or other fields, in which its failure to function or perform may reasonably be expected to result in loss of life or in significant injury or damage to person or property.
 - b. A critical component is one whose failure to function or perform may reasonably be expected to result, whether directly or indirectly, in the loss of the safety or effectiveness of the device or system containing it, and which must therefore meet very high standards of performance and reliability.
- It is the responsibility of the buyer or distributor of an AKM product who distributes, disposes of, or otherwise places the product with a third party to notify that party in advance of the above content and conditions, and the buyer or distributor agrees to assume any and all responsibility and liability for and hold AKM harmless from any and all claims arising from the use of said product in the absence of such notification.