



# AK5388

## 120dB 24-bit 192kHz 4-Channel ADC

### GENERAL DESCRIPTION

The AK5388 is a 24bit, 216kHz sampling 4-channel A/D converter for high-end audio systems. The modulator in the AK5388 uses AKM's Enhanced Dual Bit architecture, enabling the AK5388 to realize high accuracy and low cost. The AK5388 achieves 120dB dynamic range and 110dB S/(N+D), and an optional mono mode extends dynamic range to 123dB. The AK5388's digital filter features a modified FIR architecture that minimizes group delay while maintaining excellent linear phase response. So the device is suitable for professional audio applications including recording, sound reinforcement, effects processing, sound cards, and high-end A/V receivers. The AK5388 is available in 44pin LQFP package.

### FEATURES

- ❑ Sampling Rate: 8kHz ~ 216kHz
- ❑ Full Differential Inputs
- ❑ S/(N+D): 110dB
- ❑ DR, S/N: 120dB(Mono Mode: 123dB)
- ❑ Short Delay Digital Filter (GD=12.6/fs)
  - Passband: 0~21.648kHz (@fs=48kHz)
  - Ripple: 0.01dB
  - Stopband: 80dB
- ❑ Digital HPF
- ❑ Power Supply: 4.75 ~ 5.25V(Analog), 3.0 ~ 3.6V(Digital)
- ❑ Output format: 24bit MSB justified, I<sup>2</sup>S or TDM
- ❑ Cascade TDM I/F: 8ch/48kHz, 4ch/96kHz, 4ch/192kHz
- ❑ Master & Slave Mode
- ❑ Overflow Flag
- ❑ Power Dissipation: 575 mW (@fs=48kHz)
- ❑ Package: 44pin LQFP

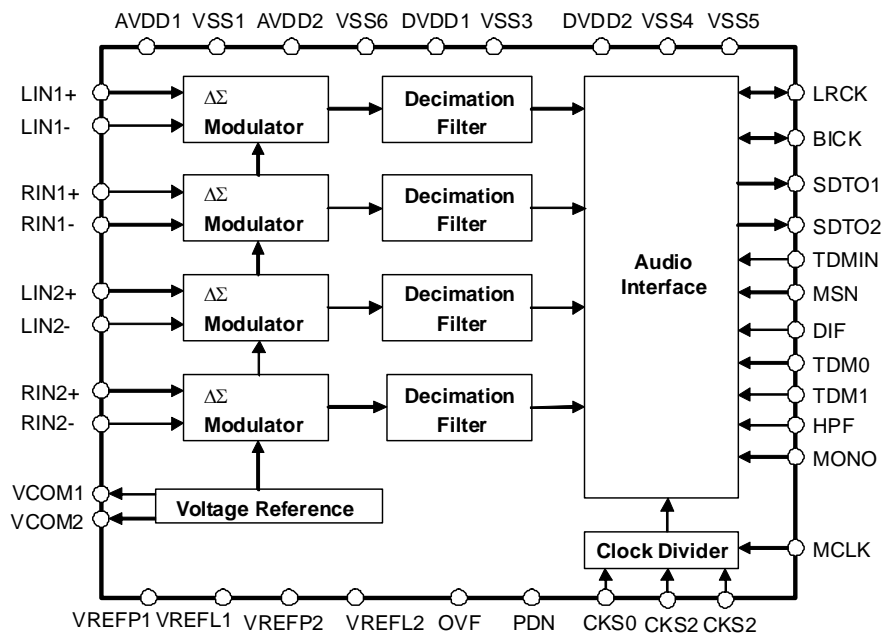

■ Ordering Guide

AK5388EQ  
AKD5388

-10 ~ +70°C  
Evaluation Board for AK5388

44pin LQFP (0.8mm pitch)

■ Pin Layout

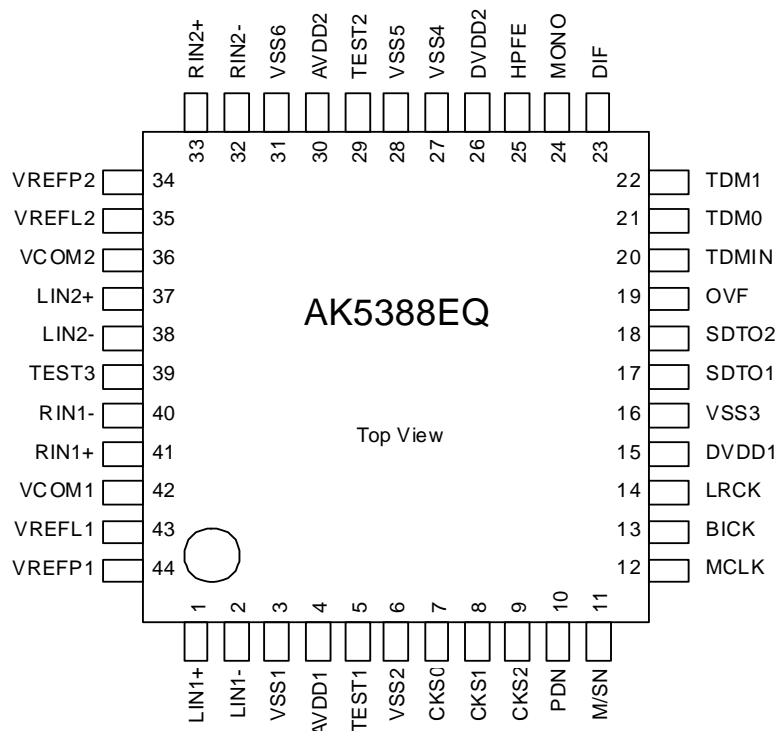

<b>PIN / FUNCTION</b>
-----------------------

No.	Pin Name	I/O	Function
1	LIN1+	I	ADC1 Lch Positive Analog Input Pin
2	LIN1-	I	ADC1 Lch Negative Analog Input Pin
3	VSS1	-	Ground Pin
4	AVDD1	-	Analog Power Supply Pin, 4.75 ~ 5.25V
5	TEST1	I	Test Pin (Connected to VSS1-6)
6	VSS2		Ground pin
7	CKS0	I	Clock Mode Select #0 Pin
8	CKS1	I	Clock Mode Select #1 Pin
9	CKS2	I	Clock Mode Select #2 Pin
10	PDN	I	Power-Down Mode Pin When "L", the circuit is in power-down mode. The AK5388 should always be reset upon power-up.
11	MSN	I	Master/Slave mode Select Pin "L": Slave mode, "H": Master mode
12	MCLK	I	Master Clock Input Pin
13	BICK	I/O	Audio Serial Data Clock Pin "L" Output in Master Mode at Power-down mode.
14	LRCK	I/O	Output Channel Clock Pin "L" Output in Master Mode at Power-down mode.
15	DVDD1	-	Digital Power Supply Pin, 3.0 ~ 3.6V
16	VSS3	-	Ground Pin
17	SDTO1	O	ADC1 Audio Serial Data Output Pin "L" Output at Power-down mode.
18	SDTO2	O	ADC2 Audio Serial Data Output Pin "L" Output at Power-down mode.
19	OVF	O	Analog Input Overflow Detect Pin This pin goes to "H" if any analog inputs overflows. "L" Output at Power-down mode.
20	TDMIN	I	TDM Data Input Pin
21	TDM0	I	TDM I/F Format Enable Pin "L": Normal Mode, "H": TDM Mode
22	TDM1	I	TDM I/F BICK Frequency Select Pin "L": Normal Mode, "H": TDM Mode
23	DIF	I	Audio Interface Format Pin "L": 24BitMSB justified, "H": 24Bit <sup>2</sup> S Compatible
24	MONO	I	Stereo/Mono mode Select Pin "L": Stereo mode, "H": Mono mode
25	HPFE	I	HPF Enable Pin "L": Disable, "H": Enable
26	DVDD2	-	Digital Power Supply Pin, 3.0 ~ 3.6V
27	VSS4	-	Ground Pin
28	VSS5		Ground pin

No.	Pin Name	I/O	Function
29	TEST2	I	Test Pin (Connected to VSS1-6)
30	AVDD2	-	Analog Power Supply Pin, 4.75 ~ 5.25V
31	VSS6	-	Ground Pin
32	RIN2-	I	ADC2 Rch Negative Analog Input Pin
33	RIN2+	I	ADC2 Rch Positive Analog Input Pin
34	VREFP2	I	ADC2 High Level Voltage Reference Input Pin
35	VREFL2	I	ADC2 Low Level Voltage Reference Input Pin
36	VCOM2	O	Common Voltage Output Pin, (AVDD2)/2 Normally connected to AVSS2 with a 0.1 $\mu$ F ceramic capacitor in parallel with an electrolytic capacitor less than 2.2 $\mu$ F.
37	LIN2+	I	ADC2 Lch Positive Analog Input Pin
38	LIN2-	I	ADC2 Lch Negative Analog Input Pin
39	TEST3	I	Test Pin (Connected to VSS1-6)
40	RIN1-	I	ADC1 Rch Negative Analog Input Pin
41	RIN1+	I	ADC1 Rch Positive Analog Input Pin
42	VCOM1	O	Common Voltage Output Pin, (AVDD1)/2 Normally connected to AVSS1 with a 0.1 $\mu$ F ceramic capacitor in parallel with an electrolytic capacitor less than 2.2 $\mu$ F.
43	VREFL1	I	ADC1 Low Level Voltage Reference Input Pin
44	VREFP1	I	ADC1 High Level Voltage Reference Input Pin

Note: All digital input pins should not be left floating.

## ■ Handling of Unused Pin

The unused I/O pins should be processed appropriately as below.

Classification	Pin Name	Setting
Analog	LIN1+/-, RIN1+/-	These pins should be connected to VSS1-6
	LIN2+/-, RIN+/-	These pins should be connected to VSS1-6
Digital	OVF	This pin should be open.
	TEST1	This pin should be connected to VSS1-6
	TEST2	This pin should be connected to VSS1-6
	TEST3	This pin should be connected to VSS1-6

### ABSOLUTE MAXIMUM RATINGS

(VSS1-6=0V; Note 1)

Parameter		Symbol	min	max	Units
Power Supplies:	Analog	AVDD1	-0.3	6.0	V
	Analog	AVDD2	-0.3	6.0	V
	Digital	DVDD1	-0.3	6.0	V
	Digital Output Buffer	DVDD2	-0.3	6.0	V
Input Current, Any Pin Except Supplies		IIN	-	±10	mA
Analog Input Voltage (Note 2)		VINA	-0.3	AVDD1+0.3	V
		VINA	-0.3	AVDD2+0.3	
Digital Input Voltage (Note 3)		VIND	-0.3	DVDD1+0.3	V
		VIND	-0.3	DVDD2+0.3	
Ambient Temperature (power applied)		Ta	-10	70	°C
Storage Temperature		Tstg	-65	150	°C

Note 1. All voltages with respect to VSS1-6 pins.

Note 2. VREFP1, VREFP2, VREFL1, VREFL2, AINL1/2+, AINL1/2-, AINR1/2+ and AINR1/2- pins

Note 3. PDN, CKS0, CKS1, CKS2, TDMIN, MCLK, BICK, LRCK, DIF, TDM0, TDM1, HPFE, MONO and TST1/2/3 pins

**WARNING:** Operation at or beyond these limits may result in permanent damage to the device.  
Normal operation is not guaranteed at these extremes.

<b>RECOMMENDED OPERATING CONDITIONS</b>
---

(VSS1-6=0V; Note 1)

Parameter		Symbol	min	typ	max	Units
Power Supplies: (Note 4)	Analog	AVDD1	4.75	5.0	5.25	V
	Analog	AVDD2	4.75	5.0	5.25	V
	Digital	DVDD1/2	3.0	3.3	3.6	V
Voltage Reference (Note 5)	“H” voltage Reference	VREFP1	AVDD1-0.5	-	AVDD1	V
		VREFP2	AVDD2-0.5	-	AVDD2	V
	“L” voltage reference	VREFL1	VSS1-6	-	-	V
		VREFL2	VSS1-6	-	-	V
	VREFP1 – VREFL1	$\Delta$ VREF	AVDD1-0.5	-	AVDD1	V
	VREFP2 – VREFL2	$\Delta$ VREF	AVDD2-0.5	-	AVDD2	V

Note 1. All voltages with respect to VSS1-6 pins.

Note 4. The power up sequence between AVDD1/2 and DVDD1/2 is not critical.

Note 5. VREFL– and VREFR– pins should be connected to VSS1-6 pins.

Analog input voltage scales with voltage of  $\{(VREFP) - (VREFL)\}$ .

$V_{in} (typ, @ 0dB) = \pm 2.8 \times \{(VREF+) - (VREF-)\} / 5 [V]$ .

WARNING: AKM assumes no responsibility for the usage beyond the conditions in this datasheet.

## ANALOG CHARACTERISTICS

(Ta = 25°C; AVDD1/2=5.0V; DVDD1/2=3.3V; VSS1-6=0V; VREFP1=VREFP2=AVDD, VREFL1 = VREFL2 = VSS1-6; fs=48kHz, 96kHz, 192kHz; BICK=64fs; Signal Frequency=1kHz; 24bit Data; Measurement frequency=10Hz ~ 20kHz at fs = 48kHz, 40Hz ~ 40kHz at fs = 96kHz, 40Hz ~ 40kHz at fs = 192kHz; unless otherwise specified)

Parameter	min	typ	max	Units		
<b>Analog Input Characteristics:</b>						
Resolution	-	-	24	Bits		
Input Voltage (Note 6)	±2.7	±2.8	±2.9	Vpp		
S/(N+D)	fs=48kHz BW=20kHz	-1dBFS	100	110	-	dB
		-20dBFS	-	97	-	dB
		-60dBFS	-	57	-	dB
	fs=96kHz BW=40kHz	-1dBFS	97	107	-	dB
		-20dBFS	-	90	-	dB
		-60dBFS	-	50	-	dB
	fs=192kHz BW=40kHz	-1dBFS	-	107	-	dB
		-20dBFS	-	90	-	dB
		-60dBFS	-	50	-	dB
Dynamic Range (-60dBFS with A-weighted)	Stereo Mode	114	120	-	dB	
	Mono Mode	-	123	-	dB	
S/N (A-weighted)	Stereo Mode	114	120	-	dB	
	Mono Mode	-	123	-	dB	
Input Resistance	3.3	3.7	4.1	kΩ		
Interchannel Isolation	110	120		dB		
Interchannel Gain Mismatch		0.1	0.5	dB		
Power Supply Rejection (Note 7)		60	-	dB		
<b>Power Supplies</b>						
Power Supply Current						
Normal Operation (PDN pin = "H")						
AVDD1/2		105	130	mA		
DVDD (fs=48kHz)		15	22	mA		
DVDD (fs=96kHz)		27	39	mA		
DVDD (fs=192kHz)		20	29	mA		
Power down mode (PDN pin = "L") (Note 8)						
AVDD+DVDD		10	100	μA		

Note 6. This value is (LIN+)-(LIN-) and (RIN+)-(RIN-). Input voltage is proportional to VREF voltage.  
 $V_{in} = 0.56 \times VREF1/2 (V_{pp})$ .

Note 7. PSR is applied to AVDD1/2 and DVDD1/2 with 1kHz, 20mVpp. The VREFP1 and VREFP2 pins held a constant voltage.

Note 8. All digital input pins are held DVDD1/2 or VSS3/4.

**FILTER CHARACTERISTICS (fs=48kHz)**

(Ta=25°C; AVDD1/2=4.75 ~ 5.25V; DVDD1/2=3.0 ~ 3.6V; DFS1 = "L", DFS0 = "L")

Parameter	Symbol	min	typ	max	Units
<b>ADC Digital Filter (Decimation LPF):</b>					
Passband (Note 9)	-0.01dB	PB	0	21.6	kHz
	-0.1dB		-	22.0	kHz
	-3.0dB		-	23.8	kHz
	-6.0dB		-	24.4	kHz
Stopband	SB	27.9			kHz
Passband Ripple	PR			±0.01	dB
Stopband Attenuation	SA	80			dB
Group Delay (Note 10)	GD		12.6		1/fs
Group Delay Distortion	ΔGD		±0.01		μs
<b>ADC Digital Filter (HPF):</b>					
Frequency Response (Note 9)	-3dB	FR		1.0	Hz
	-0.1dB			6.5	Hz

**FILTER CHARACTERISTICS (fs=96kHz)**

(Ta=25°C; AVDD1/2=4.75 ~ 5.25V; DVDD1/2=3.0 ~ 3.6V; DFS1 = "L", DFS0 = "H")

Parameter	Symbol	min	typ	max	Units
<b>ADC Digital Filter (Decimation LPF):</b>					
Passband (Note 9)	-0.01dB	PB	0	43.3	kHz
	-0.1dB		-	44.2	kHz
	-3.0dB		-	47.6	kHz
	-6.0dB		-	48.9	kHz
Stopband	SB	55.9			kHz
Passband Ripple	PR			±0.01	dB
Stopband Attenuation	SA	80			dB
Group Delay (Note 10)	GD		12.6		1/fs
Group Delay Distortion	ΔGD		±0.013		μs
<b>ADC Digital Filter (HPF):</b>					
Frequency Response (Note 9)	-3dB	FR		1.0	Hz
	-0.1dB			6.5	Hz

Note 9. The passband and stopband frequencies scale with fs. The reference frequency of these responses is 1kHz.

Note 10. The calculated delay time induced by digital filtering. This time is from the input of an analog signal to the setting of 24bit data both channels to the ADC output register for ADC.



**FILTER CHARACTERISTICS (fs=192kHz)**

(Ta=25°C; AVDD1/2=4.75 ~ 5.25V; DVDD1/2=3.0 ~ 3.6V; DFS1 = "H", DFS0 = "L")

Parameter	Symbol	min	typ	max	Units
<b>ADC Digital Filter (Decimation LPF):</b>					
Passband (Note 11)	PB	-0.08dB	-	83.0	kHz
		-0.1dB	-	83.4	kHz
		-3.0dB	-	99.9	kHz
		-6.0dB	-	106.5	kHz
Stopband	SB	141.1			kHz
Passband Ripple	PR			±0.08	dB
Stopband Attenuation	SA	80			dB
Group Delay (Note 12)	GD		9.8		1/fs
Group Delay Distortion	ΔGD		0		μs
<b>ADC Digital Filter (HPF):</b>					
Frequency Response (Note 11)	FR	-3dB	1.0		Hz
		-0.1dB	6.5		Hz

Note 11. The passband and stopband frequencies scale with fs. The reference frequency of these responses is 1kHz.

Note 12. The calculated delay time induced by digital filtering. This time is from the input of an analog signal to the setting of 24bit data both channels to the ADC output register for ADC.

**DC CHARACTERISTICS**

(Ta=25°C; AVDD1/2=4.75 ~ 5.25V; DVDD1/2=3.0 ~ 3.6V)

Parameter	Symbol	min	typ	Max	Units
High-Level Input Voltage	VIH	70%DVDD1	-	-	V
Low-Level Input Voltage	VIL	70%DVDD2	-	-	V
		-	-	30%DVDD1	V
High-Level Output Voltage (Iout=-400μA)	VOH	DVDD1-0.4	-	-	V
		DVDD2-0.4	-	-	V
Low-Level Output Voltage (Iout=400μA)	VOL	-	-	0.4	V
Input Leakage Current	Iin	-	-	±10	μA

## SWITCHING CHARACTERISTICS

(Ta=25°C; AVDD1/2=4.75 ~ 5.25V; DVDD1/2=3.0 ~ 3.6V; CL=20pF)

Parameter	Symbol	min	typ	max	Units	
<b>Master Clock Timing</b>						
Master Clock	128fs:	fCLK	1.024	24.576	27.648	MHz
	Pulse Width Low	tCLKL	0.4fCLK			ns
	Pulse Width High	tCLKH	0.4fCLK			ns
	192fs:	fCLK	1.536	36.864	41.472	MHz
	Pulse Width Low	tCLKL	0.4fCLK			ns
	Pulse Width High	tCLKH	0.4fCLK			ns
	256fs:	fCLK	2.048	12.288	27.648	MHz
	Pulse Width Low	tCLKL	0.4fCLK			ns
	Pulse Width High	tCLKH	0.4fCLK			ns
	384fs:	fCLK	3.072	18.432	41.472	MHz
	Pulse Width Low	tCLKL	0.4fCLK			ns
	Pulse Width High	tCLKH	0.4fCLK			ns
	512fs:	fCLK	4.096	24.576	27.648	MHz
	Pulse Width Low	tCLKL	0.4fCLK			ns
	Pulse Width High	tCLKH	0.4fCLK			ns
	768fs:	fCLK	6.144	36.864	41.472	MHz
	Pulse Width Low	tCLKL	0.4fCLK			ns
	Pulse Width High	tCLKH	0.4fCLK			ns
<b>LRCK Timing (Slave Mode)</b>						
<b>Normal mode (TDM1="L", TDM0="L")</b>						
	LRCK Frequency	fs	8		216	kHz
	Duty Cycle	Duty	45		55	%
<b>TDM256 MODE (TDM1="L", TDM0="H")</b>						
	LRCK Frequency	fs	8		54	kHz
	"H" time	tLRH	1/256fs			ns
	"L" time	tLRL	1/256fs			ns
<b>TDM128 MODE (TDM1="H", TDM0="H")</b>						
	LRCK Frequency	fs	8		216	kHz
	"H" time	tLRH	1/128fs			ns
	"L" time	tLRL	1/128fs			ns
<b>LRCK Timing (Master Mode)</b>						
<b>Normal mode (TDM1="L", TDM0="L")</b>						
	LRCK Frequency	fs	8		216	kHz
	Duty Cycle	Duty		50		%
<b>TDM256 MODE (TDM1="L", TDM0="H")</b>						
	LRCK Frequency	fs	8		54	kHz
	"H" time (Note 13)	tLRH		1/8fs		ns
<b>TDM128 MODE (TDM1="H", TDM0="H")</b>						
	LRCK Frequency	fs	8		216	kHz
	"H" time (Note 13)	tLRH		1/4fs		ns

Note 13. "L" time at I<sup>2</sup>S format

Parameter	Symbol	min	typ	max	Units
<b>Audio Interface Timing (Slave mode)</b>					
<b>Normal mode (TDM1="L", TDM0="L")</b>					
BICK Period					
Normal Speed Mode	TBCK	1/128fs			ns
Double , Quad Speed Mode	TBCK	1/64fs			ns
Duty Cycle	Duty	40		60	%
LRCK Edge to BICK "↑" (Note 14)	tLRB	20			ns
BICK "↑" to LRCK Edge (Note 14)	tBLR	20			ns
LRCK to SDTO1/2 (MSB) (Except I <sup>2</sup> S mode)	tLRS				ns
BICK "↓" to SDTO1/2	tBSD			20	ns
<b>TDM256 mode (TDM1="L", TDM0="H")</b>					
BICK Period	tBCK	1/256fs			ns
Duty Cycle	Duty	40		60	%
LRCK Edge to BICK "↑" (Note 14)	tLRB	20			ns
BICK "↑" to LRCK Edge (Note 14)	tBLR	20			ns
BICK "↓" to SDTO1/2 (Note 15)	tBSD			20	ns
TDMIN Setup time	tTDMS	16			ns
<b>TDM128 mode (TDM1="H", TDM0="H")</b> (8KHz ≤ fs < 108KHz)					
BICK Period	tBCK	1/128fs			ns
Duty Cycle	Duty	40		60	%
LRCK Edge to BICK "↑" (Note 14)	tLRB	20			ns
BICK "↑" to LRCK Edge (Note 14)	tBLR	20			ns
BICK "↓" to SDTO1 (Note 15)	tBSD			20	ns
<b>TDM128 mode (TDM1="H", TDM0="H")</b> (108KHz < fs ≤ 216KHz)					
BICK Period	tBCK	1/128fs			ns
Duty Cycle	Duty	40		60	%
LRCK Edge to BICK "↑" (Note 14)	tLRB	10			ns
BICK "↑" to LRCK Edge (Note 14)	tBLR	10			ns
SDTO1 Setup time BICK "↑" (Note 15)	tBSS	10			ns
SDTO1 Hold time BICK "↑" (Note 15)	tBSH	5			ns

Parameter	Symbol	min	typ	max	Units
<b>Audio Interface Timing (Master mode)</b>					
<b>Normal mode (TDM1="L", TDM0="L")</b>					
BICK Frequency	fBCK		64fs		Hz
BICK Duty	dBCK		50		%
BICK "↓" to LRCK	tMBLR	-20		20	ns
BICK "↓" to SDTO1/2	tBSD	-20		20	ns
<b>TDM256 mode (TDM1="L", TDM0="H")</b>					
BICK Frequency	fBCK		256fs		Hz
BICK Duty (Note 16)	dBCK		50		%
BICK "↓" to LRCK	tMBLR	-12		12	ns
BICK "↓" to SDTO1 (Note 15)	tBSD	-20		20	ns
<b>TDM128 mode (TDM1="H", TDM0="H") (8KHz ≤ fs &lt; 108KHz)</b>					
BICK Frequency	fBCK		128fs		Hz
BICK Duty	dBCK		50		%
BICK "↓" to LRCK	tMBLR	-12		12	ns
BICK "↓" to SDTO1 (Note 15)	tBSD	-20		20	ns
<b>TDM128 mode (TDM1="H", TDM0="H") (108KHz &lt; fs ≤ 216KHz)</b>					
BICK Frequency	fBCK		128fs		Hz
BICK Duty	dBCK		50		%
BICK "↓" to LRCK	tMBLR	-6		6	ns
BICK "↓" to SDTO1	tBSD	-10		10	ns
<b>Power-Down &amp; Reset Timing</b>					
PDN Pulse Width (Note 17)	tPD	150			ns
PDN "↑" to SDTO1/2 valid (Note 18)	tPDV		516		1/fs

Note 14. BICK rising edge must not occur at the same time as LRCK edge.

Note 15. SDTO2 output is fixed to "L".

Note 16. This value is MCLK=512fs. Duty cycle is not guaranteed when MCLK=256fs/384fs.

Note 17. The AK5388 can be reset by bringing the PDN pin = "L".

Note 18. This cycle is the number of LRCK rising edges from the PDN pin = "H". The value is when the AK5388 is in master mode. In case of in slave mode, the value will be 1LRCK clock cycle (1/fs) longer.

■ Timing Diagram

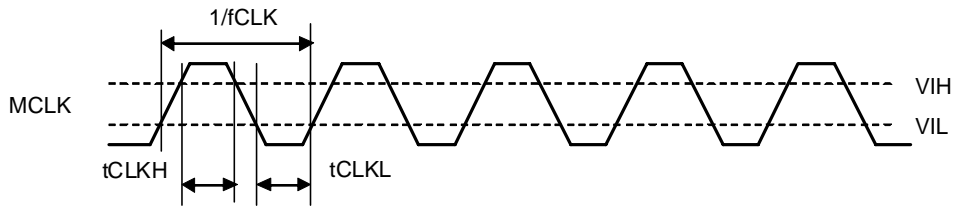

Figure 1. MCLK Timing (TDM0 pin = "L" or "H")

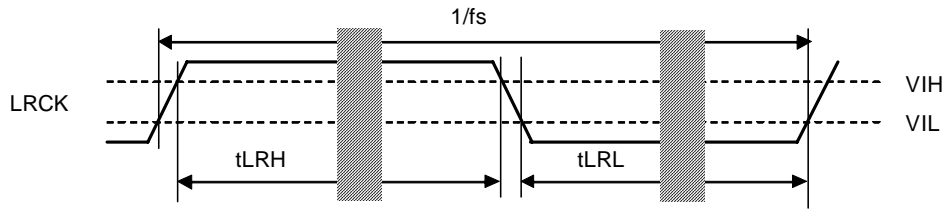

Figure 2. LRCK Timing (TDM0 pin = "L" or "H")

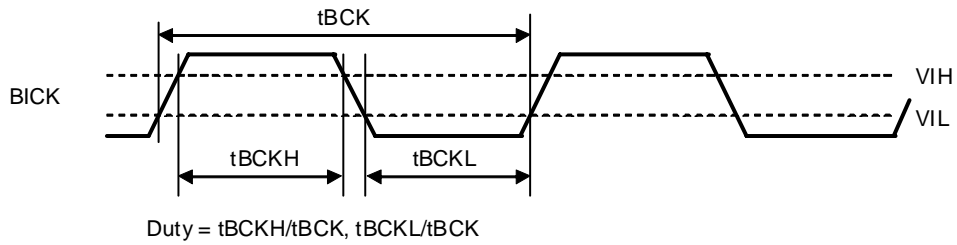

Figure 3. BICK Timing (TDM0 pin = "L" or "H")

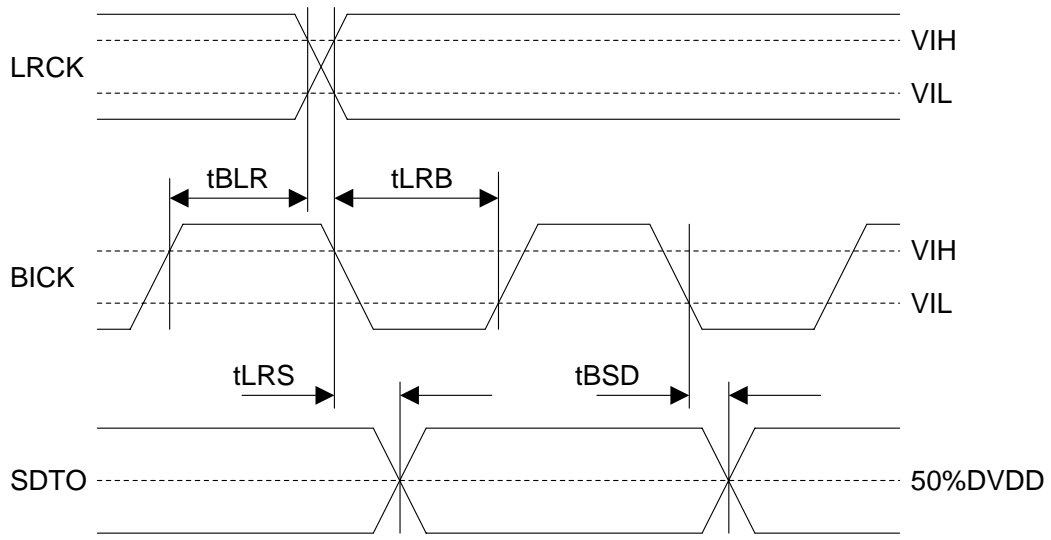

Figure 4. Audio Interface Timing (Slave mode, TDM0 pin = "L")

Note: SDTO shows SDTO1 and SDTO2.

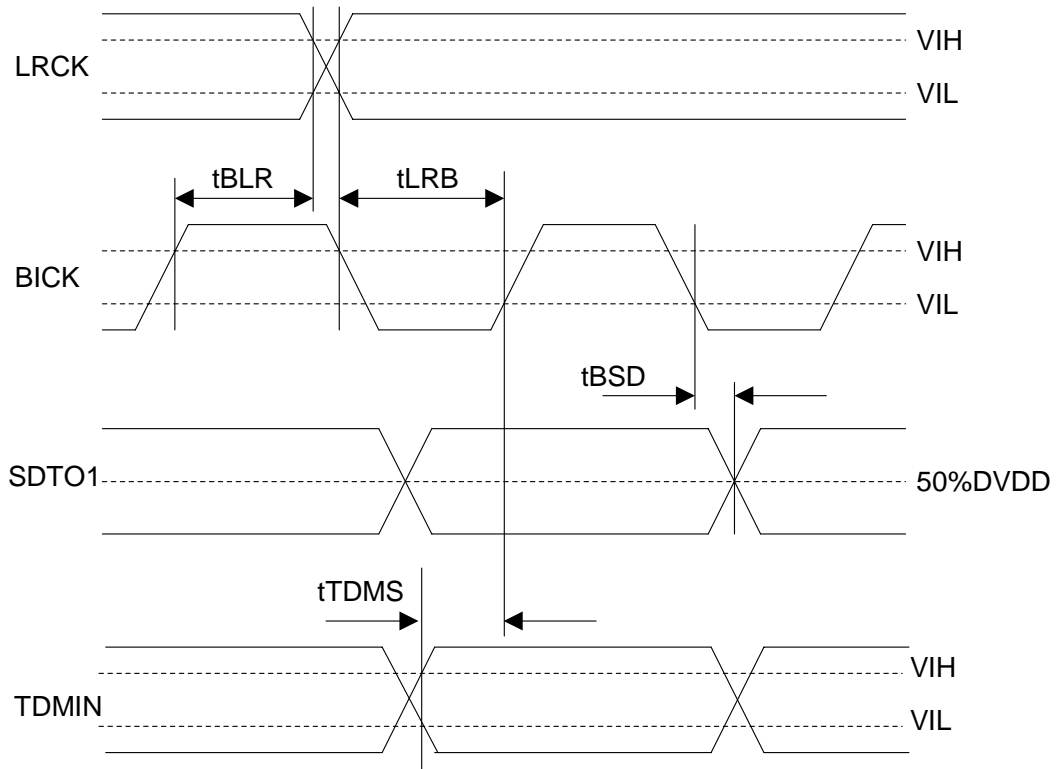

Figure 5. Audio Interface Timing (Slave mode, TDM0 pin = "H")

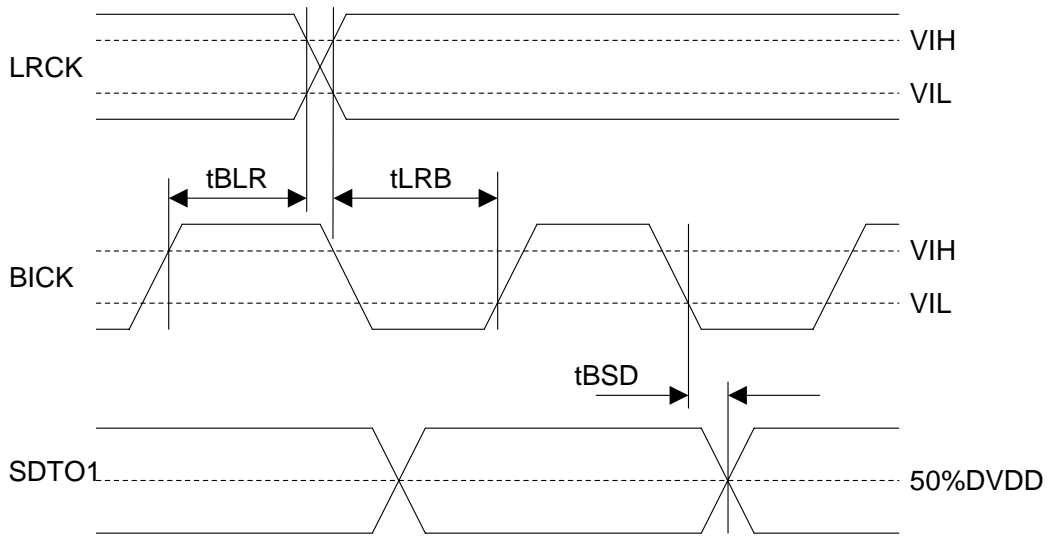

Figure 6. Audio Interface Timing (Slave mode, TDM0 pin = “H”, TDM1 pin = “H”,  $8\text{KHz} \leq f_s < 108\text{KHz}$ )

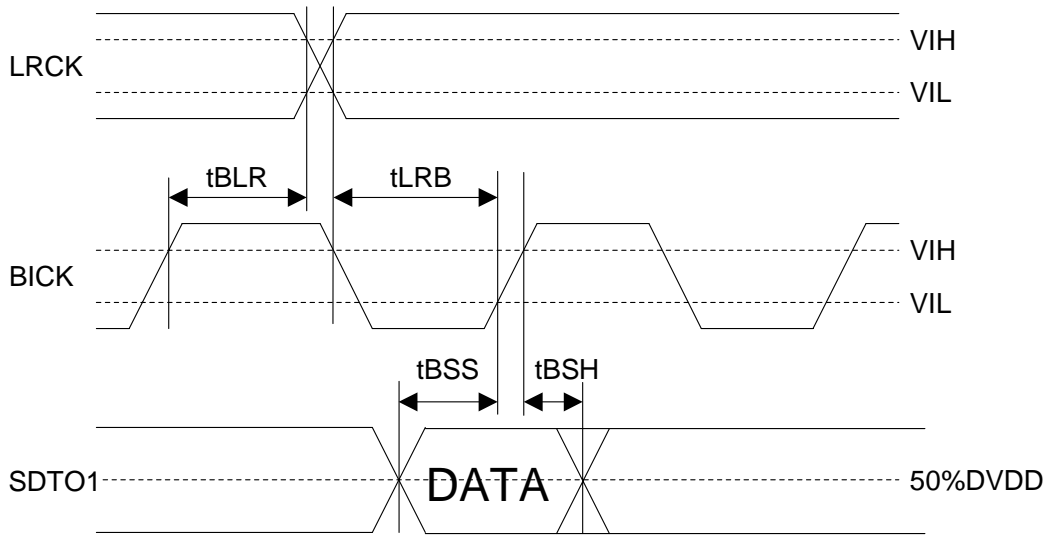

Figure 7. Audio Interface Timing (Slave mode, TDM0 pin = “H”, TDM1 pin = “H”,  $108\text{KHz} < f_s \leq 216\text{KHz}$ )

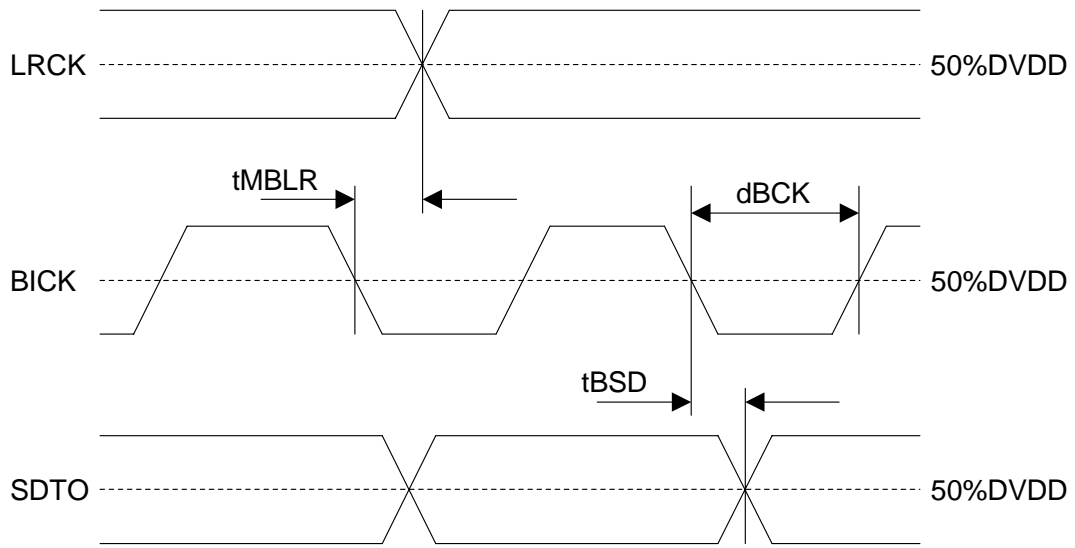

Figure 8. Audio Interface Timing (Master mode)

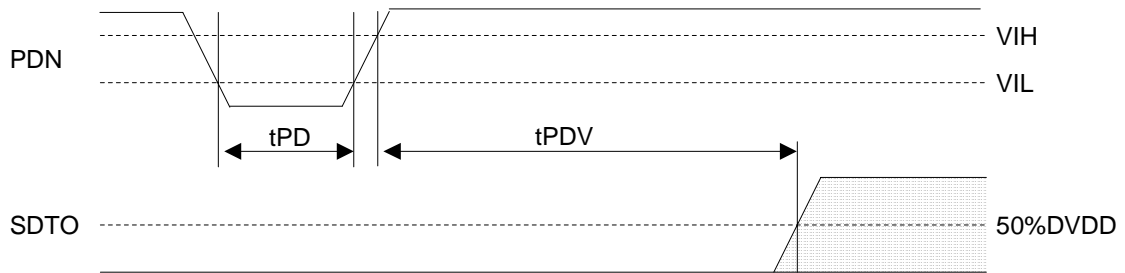

Figure 9. Power Down & Reset Timing

Note: SDTO shows SDTO1 and SDTO2.



<b>OPERATION OVERVIEW</b>
---------------------------

### ■ System Clock

MCLK (128fs/192fs/256fs/384fs/512fs/768fs), BICK (48fs~) and LRCK (fs) clocks are required in slave mode. The LRCK clock input must be synchronized with MCLK, however the phase is not critical. [Table 1](#), [Table 2](#) and [Table 3](#) show the relationship of typical sampling frequency and the system clock frequency. MCLK frequency is selected by CKS1-0 pins as shown in [Table 4](#).

Since the AK5388 includes a phase detection circuit for LRCK, the AK5388 is reset automatically when the synchronization is out of phase after changing the clock frequencies.

All external clocks (MCLK, BICK and LRCK) must be present unless the PDN pin = "L". If these clocks are not provided, the AK5388 may draw excess current due to its use of internal dynamically refreshed logic. If the external clocks are not present, place the AK5388 in power-down mode (PDN pin = "L"). In master mode, the master clock (MCLK) must be provided unless the PDN pin = "L". In case of using two or more devices, the AK5388 should be reset by the PDN pin when changing clocks, changing clock modes and switching digital interfaces for a synchronization. Clock or mode changes should be made during the reset, and a stable clock is needed after the reset.

fs	MCLK					
	128fs	192fs	256fs	384fs	512fs	768fs
32kHz	N/A	N/A	8.192MHz	12.288MHz	16.384MHz	24.576MHz
48kHz	N/A	N/A	12.288MHz	18.432MHz	24.576MHz	36.864MHz
96kHz	N/A	N/A	24.576MHz	N/A	N/A	N/A
192kHz	24.576MHz	36.864MHz	N/A	N/A	N/A	N/A

(N/A: Not available)

Table 1. System Clock Example (Slave Mode)

fs	MCLK					
	128fs	192fs	256fs	384fs	512fs	768fs
32kHz	N/A	N/A	8.192MHz	12.288MHz	16.384MHz	24.576MHz
48kHz	N/A	N/A	12.288MHz	18.432MHz	24.576MHz	36.864MHz
96kHz	N/A	N/A	24.576MHz	36.864MHz	N/A	N/A
192kHz	24.576MHz	36.864MHz	N/A	N/A	N/A	N/A

(N/A: Not available)

Table 2. System Clock Example (Master Mode)

fs	MCLK					
	128fs	192fs	256fs	384fs	512fs	768fs
32kHz	N/A	N/A	N/A	N/A	16.384MHz	24.576MHz
48kHz	N/A	N/A	N/A	N/A	24.576MHz	36.864MHz
96kHz	N/A	N/A	24.576MHz	36.864MHz	N/A	N/A
192kHz	24.576MHz	36.864MHz	N/A	N/A	N/A	N/A

(N/A: Not available)

Table 3. System Clock Example (Auto Mode)

CKS2 pin	CKS1 pin	CKS0 pin	M/S Pin	MCLK Frequency
L	L	L	L	Double Speed Mode 128fs (108KHz < fs ≤ 216KHz)
			H	
L	L	H	L	Quad Speed Mode 192fs (108KHz < fs ≤ 216KHz)
			H	
L	H	L	L	Normal Speed Mode 256fs (8KHz ≤ fs ≤ 54KHz)
			H	
L	H	H	L	Double Speed Mode 256fs (54KHz < fs ≤ 108KHz)
			H	
H	L	L	L	Auto (8KHz ≤ fs ≤ 216KHz)
			H	
H	L	H	L	Double Speed Mode 384fs (54KHz < fs ≤ 108KHz)
			H	
H	H	L	L	Normal Speed Mode 384fs (8KHz ≤ fs ≤ 54KHz)
			H	
H	H	L	L	Normal Speed Mode 512fs (8KHz < fs ≤ 54KHz)
			H	
H	H	H	L	Normal Speed Mode 768fs (8KHz ≤ fs ≤ 54KHz)

Table 4. MCLK Frequency

When changing MCLK frequency in master/slave mode, the AK5388 should reset by PDN pin = “L”. (ex. 12.288MHz(@fs=48kHz) at CKS1 pin = CKS0 pin = “L”).

### ■ Audio Interface Format

12 different audio data interface formats can be selected using the TDM1-0, M/S and DIF pins as shown in [Table 5](#). The audio data format can be selected by the DIF pin. In all formats the serial data is MSB-first, 2's complement format. The SDTO1/2 is clocked out on the falling edge of BICK.

In normal mode, Mode 0-1 are the slave mode, and BICK is available up to 128fs at fs=48kHz. BICK outputs 64fs clock in Mode 2-3.

In TDM256 mode, all of the ADC's serial data (four channels) is output from the SDTO1 pins. The SDTO2 output is fixed to “L”. BICK should be fixed to 256fs. In slave mode, “H” time and “L” time of LRCK should be at least 1/256fs. In master mode, “H” time (“L” time at I<sup>2</sup>S mode) of LRCK is 1/8fs (typ). TDM256 mode only supports 48kHz sampling.

In TDM128 mode, all of the ADC's serial data (four channels) is output from the SDTO1 pin. The SDTO2 output is fixed to “L”. BICK should be fixed to 128fs. In the slave mode, “H” time and “L” time of LRCK should be at least 1/128fs. In master mode, “H” time (“L” time at I<sup>2</sup>S mode) of LRCK is 1/4fs (typ). TDM128 mode supports up to 192kHz sampling.

Mode	TDM1	TDM0	M/S	DIF	SDTO	LRCK		BICK	
							I/O		I/O
0	Normal	L	L	L	24bit, MSB justified	H/L	I	48-128fs	I
1				H	24bit, I <sup>2</sup> S Compatible	L/H	I	48-128fs	I
2				L	24bit, MSB justified	H/L	O	64fs	O
3				H	24bit, I <sup>2</sup> S Compatible	L/H	O	64fs	O
4	TDM256	L	H	L	24bit, MSB justified	↑	I	256fs	I
5				H	24bit, I <sup>2</sup> S Compatible	↓	I	256fs	I
6				L	24bit, MSB justified	↑	O	256fs	O
7				H	24bit, I <sup>2</sup> S Compatible	↓	O	256fs	O
8	TDM128	H	H	L	24bit, MSB justified	↑	I	128fs	I
9				H	24bit, I <sup>2</sup> S Compatible	↓	I	128fs	I
10				L	24bit, MSB justified	↑	O	128fs	O
11				H	24bit, I <sup>2</sup> S Compatible	↓	O	128fs	O
12	N/A	H	L	N/A	N/A	N/A	N/A	N/A	N/A

Table 5. Audio Interface Formats (N/A: Not available)

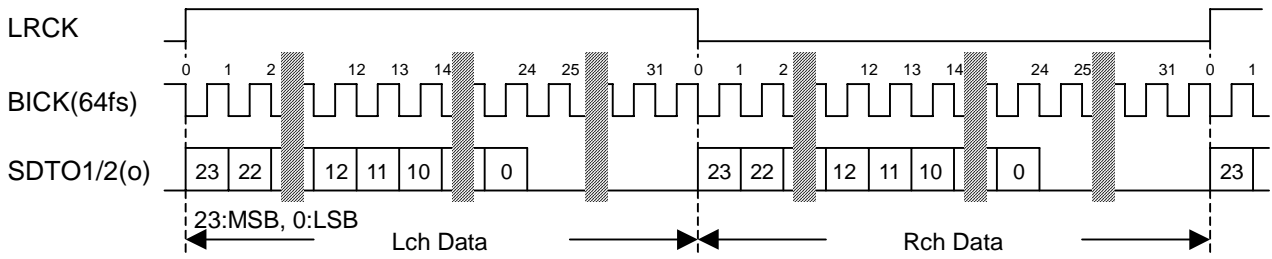

Figure 10. Mode 0/2 Timing (Normal mode, MSB justified)

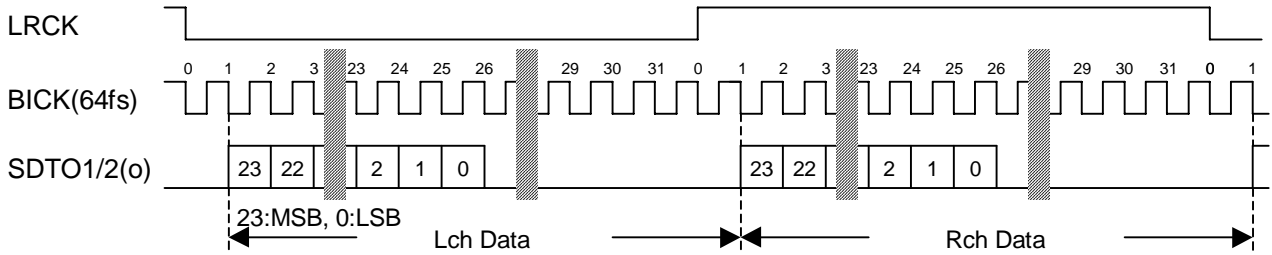

Figure 11. Mode 1/3 Timing (Normal mode, I<sup>2</sup>S Compatible)

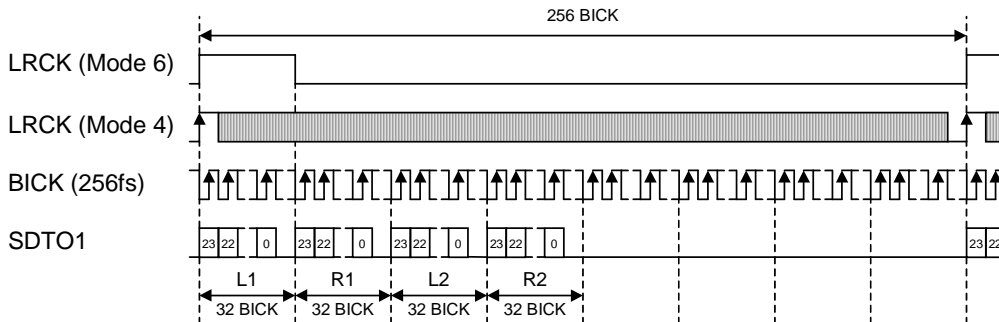

Figure 12. Mode 4/6 Timing (TDM256 mode, MSB justified)

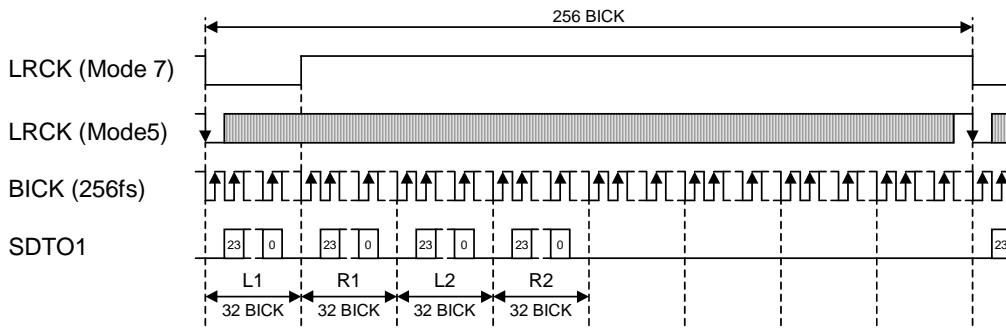

Figure 13. Mode 5/7 Timing (TDM256 mode, I<sup>2</sup>S Compatible)

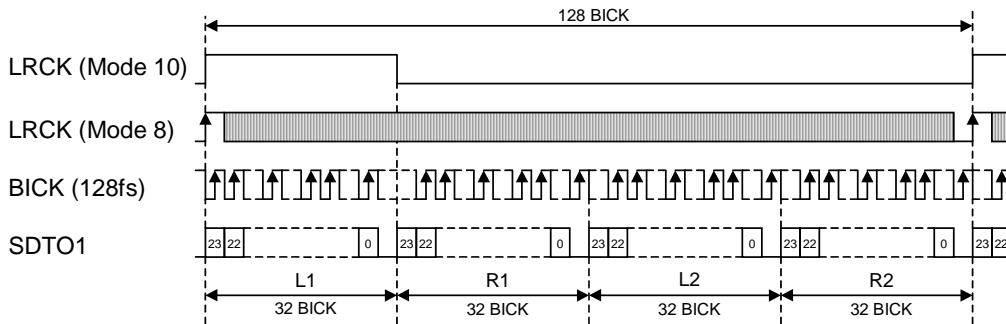

Figure 14. Mode 8/10 Timing (TDM128 mode, MSB justified)

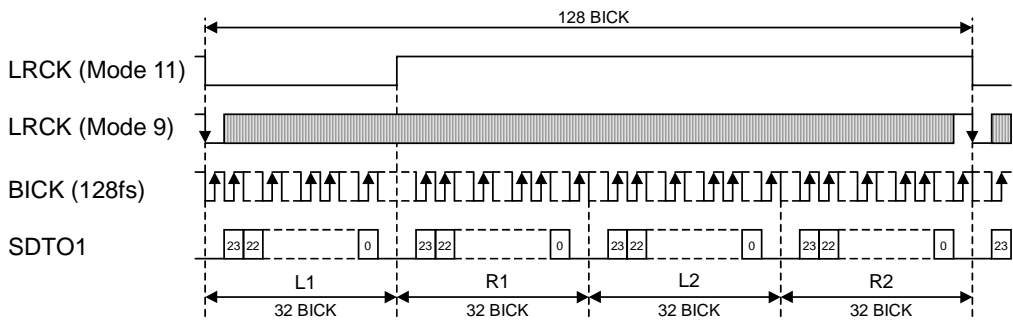

Figure 15. Mode 9/11 Timing (TDM128 mode, I<sup>2</sup>S Compatible)

## ■ Digital High Pass Filter (HPF)

The ADC has a digital high pass filter for DC offset cancellation. The HPF is controlled by the HPFE pin. If the HPF setting (ON/OFF) is changed during operation, a click noise occurs due to the change in DC offset. The HPF setting should only be changed when the PDN pin = "L".

## ■ Overflow Detection

The AK5388 has an overflow detect function for the analog input. The OVF pin goes to "H" if either channel overflows (more than  $-0.3\text{dBFS}$ ). OVF output for overflowed analog input has the same group delay as the ADC ( $\text{GD}=13/\text{fs}=0.27\text{ms}@fs=48\text{kHz}$ ). OVF is "L" for  $516/\text{fs}$  ( $=10.75\text{ms}@fs=48\text{kHz}$ ) after the PDN pin = "↑", and then overflow detection is enabled.

## ■ Power Down and Reset

The AK5388 is placed in the power-down mode by bringing PDN pin "L" and the digital filter is also reset at the same time. This reset should always be done after power-up. In the power-down mode, the VCOM is AGND level. An analog initialization cycle starts after exiting the power-down mode. The output data SDTO is valid after 516 cycles of LRCK clock in master mode (517 cycles in slave mode). During initialization, the ADC digital data outputs of both channels are forced to "0". The ADC outputs settle to data correspondent to the input signals after the end of initialization (Settling takes approximately the group delay time).

The AK5388 should be reset once by bringing the PDN pin "L" after power-up. The internal timing starts clocking by the rising edge (falling edge at Mode 1) of LRCK after exiting from reset and power down state by MCLK.

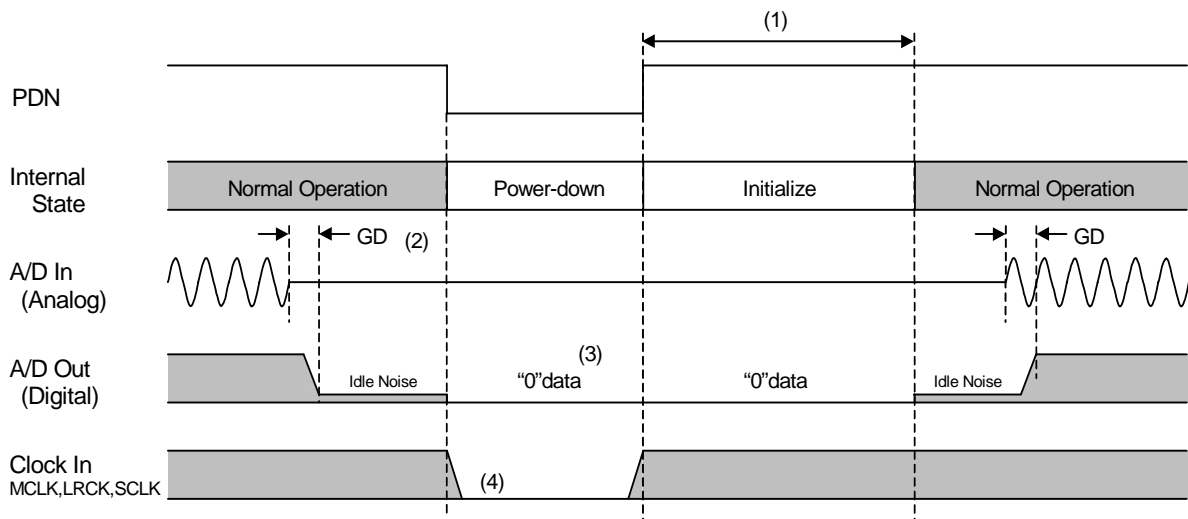

Notes:

- (1)  $517/\text{fs}$  in slave mode and  $516/\text{fs}$  in master mode.
- (2) Digital output corresponding to analog input has group delay (GD).
- (3) A/D output is "0" data in power-down state.
- (4) When the external clocks (MCLK, SCLK, LRCK) are stopped, the AK5388 should be in the power-down state.

Figure 16. Power-down/up sequence example

■ Cascade TDM Mode

The AK5388 supports cascading of up to two devices in a daisy chain configuration in TDM256 mode. In this mode, SDTO1 pin of device #1 is connected to TDMIN pin of device #2. The SDTO1 pin of device #2 can output 8-channels of TDM data multiplexed with 4-channel of TDM data from device #1 and 4-channel of TDM data from device #2. Figure 17 shows a connection example of a daisy chain.

When using two AK5388's in slave mode by cascade connection, the internal timing between device #1 and #2 may differ for 1MCLK clock cycle. BICK falling edge must be more than ±10ns from a MICK rising edge to prevent this phase difference between two devices. (Table 6)

BICK must be divided by two on a MCLK falling edge (Figure 19) when MCLK=2 x BICK (Normal speed 512fs mode or Double speed 256fs mode), and BICK must be in-phase signal to MCLK (Figure 20) when MCLK = BICK (Normal speed 256fs mode or Quad speed 128fs mode) to achieve this internal timing synchronization.

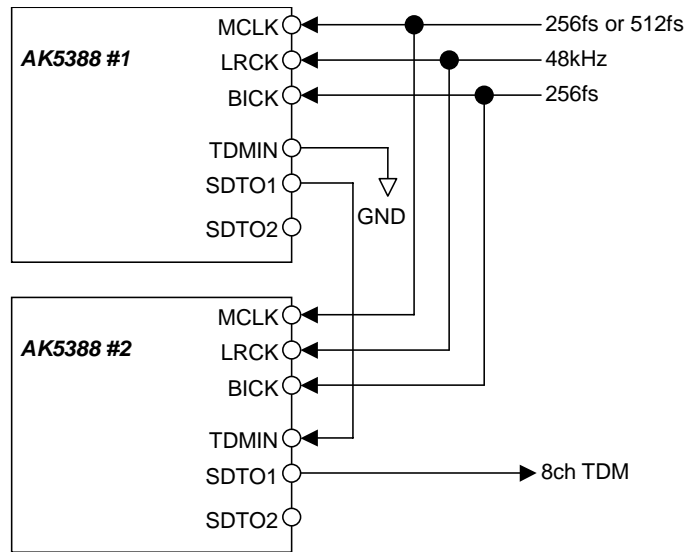

Figure 17. Cascade TDM Connection Diagram

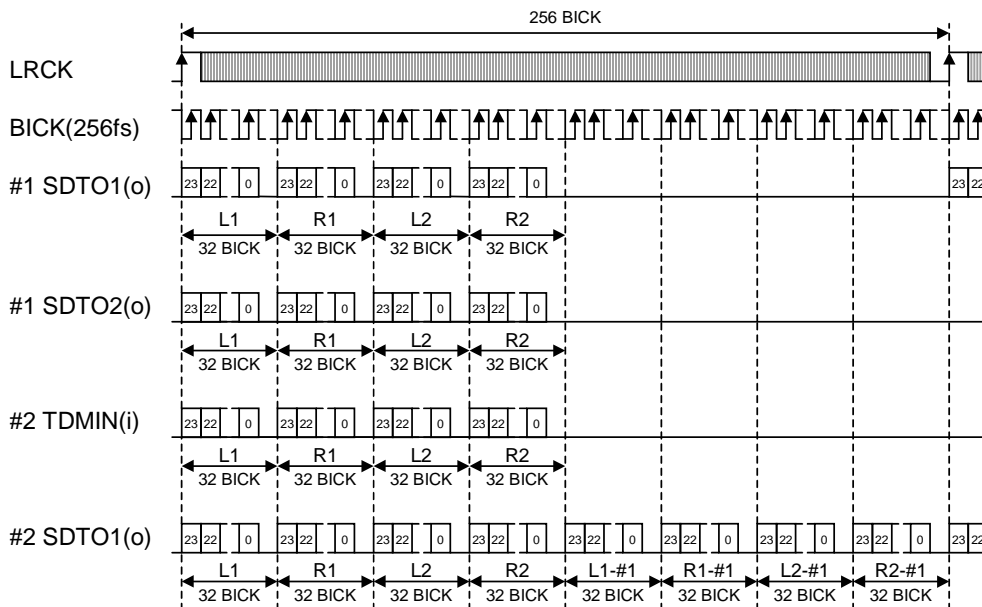

Figure 18. Cascade TDM Timing

Parameter	Symbol	min	typ	max	Units
MCLK “↑” to BICK “↓”	tMCB	10			ns
BICK “↓” to MCLK “↑”	tBIM	10			ns

Table 6 TDM Mode Clock Timing

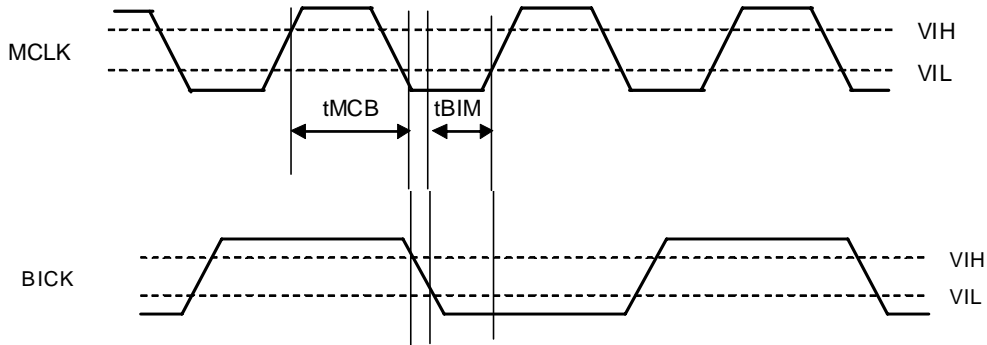

Figure 19. Audio Interface timing (Slave mode, TDM0 Mode MCLK=2 x BICK)

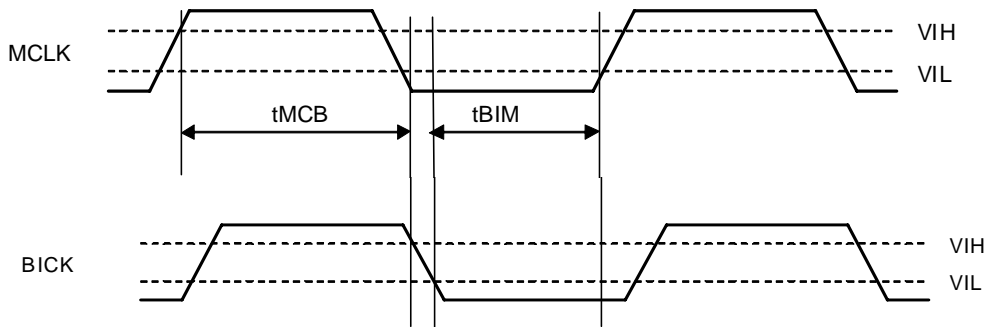

Figure 20. Audio Interface Timing (Slave mode, TDM0 Mode MCLK=BICK)

■ Mono mode

When the MONO pin is set to “H”, the AK5388 is in Mono mode. In this mode, dynamic range and S/N can be improved by approximately 3dB when the same analog signal is inputted to LIN1 and RIN1, LIN2 and RIN2. The LIN1 and RIN1 data are summed and the amplitude is attenuated into half to be output from the SDTO1 pin. The LIN2 and RIN2 data are summed and the amplitude is attenuated into half to be output from the SDTO2 pin.

MONO pin	SDTO1/2 Output Data
L	Stereo Mode
H	Mono Mode

Table 7. Setup of MONO mode

**SYSTEM DESIGN**

Figure 21 and Figure 22 show the system connection diagram. The evaluation board demonstrates application circuits, the optimum layout, power supply arrangements and measurement results.

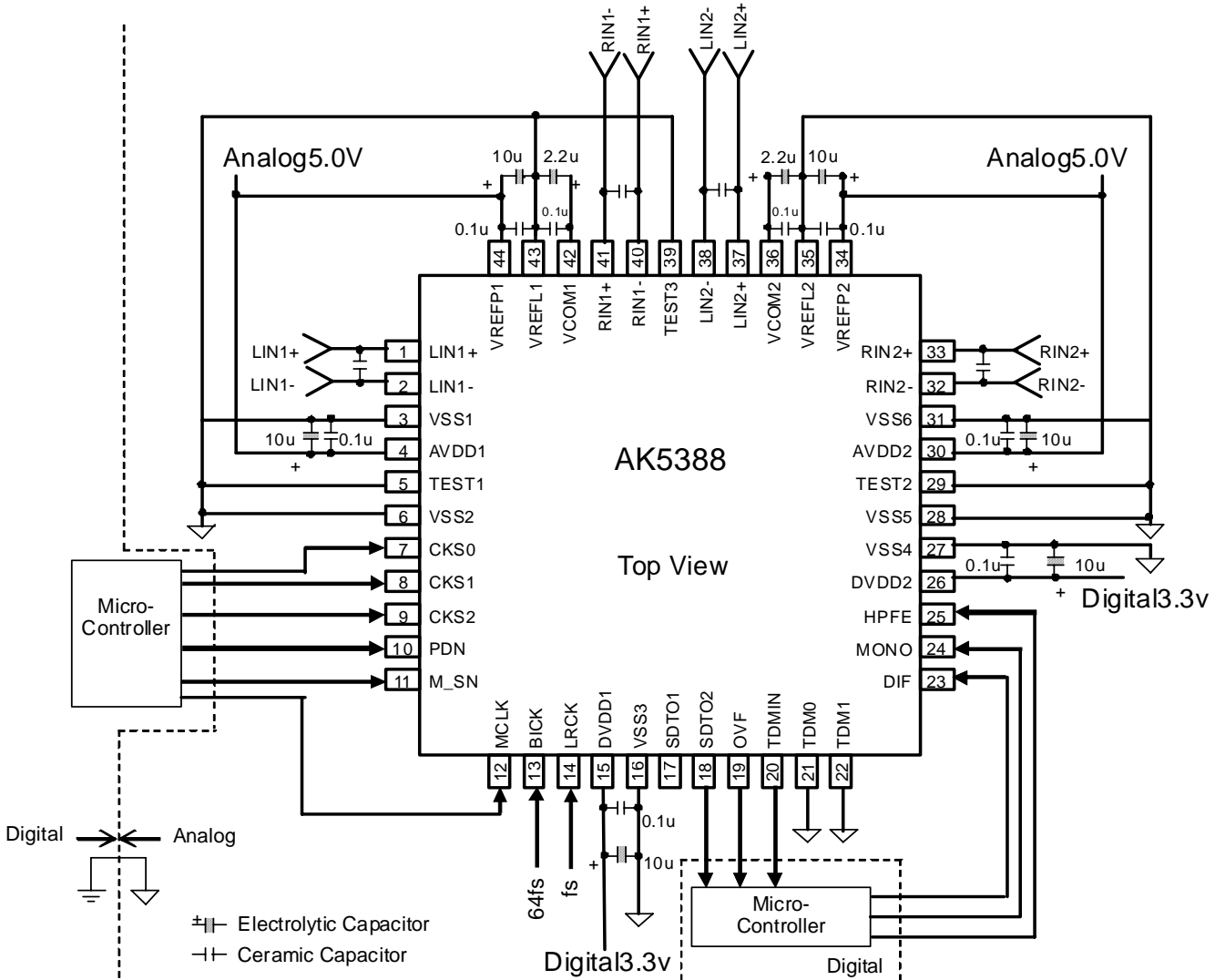

Note:

- VSS1-6 should be distributed separately from the ground of external digital devices (MPU, DSP etc.).
- All digital input pins should not be left floating.

Figure 21. Typical Connection Diagram



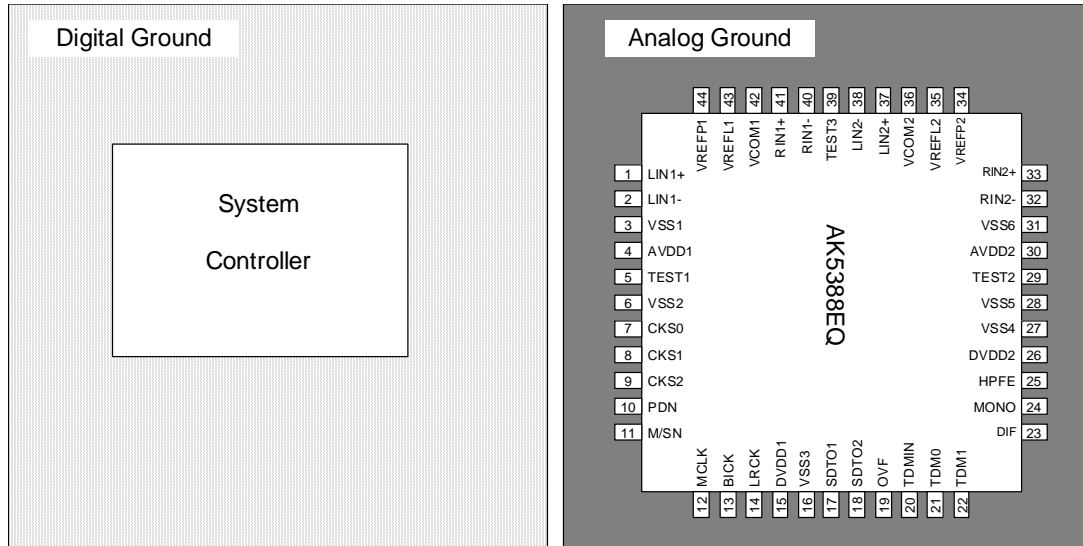

Figure 22. Ground Layout

Note: VSS1-6 must be connected to the same analog ground plane.

## 1. Grounding and Power Supply Decoupling

The AK5388 requires careful attention to power supply and grounding arrangements. AVDD1/2 and DVDD1/2 are usually supplied from the system's analog supply. Alternatively if AVDD1/2 and DVDD1/2 are supplied separately, the power up sequence is not critical. **VSS1-6 of the AK5388 must be connected to the analog ground plane.** System analog ground and digital ground should be connected together near to where the supplies are brought onto the printed circuit board. Decoupling capacitors should be as near to the AK5388 as possible, with the small value ceramic capacitor being the nearest.

## 2. Voltage Reference Inputs

The reference voltage for A/D converter is supplied from VREFP1/2 pins at VREFL1/2 reference. VREFL1/2 pins are connected to analog ground and an electrolytic capacitor over 10 $\mu$ F parallel with a 0.1 $\mu$ F ceramic capacitor between the VREFP1/2 pins and the VREFL1/2 pins eliminate the effects of high frequency noise. It is important that a ceramic capacitor should be as near to the pins as possible. All digital signals, especially clocks, should be kept away from the VREFP1/2 pins in order to avoid unwanted coupling into the AK5388.

VCOM1/2 is a signal ground for this device. An electrolytic capacitor (2.2 $\mu$ F typical) attached to the VCOM1/2 pins eliminates the effects of high frequency noise. It is important that a ceramic capacitor should be as near to the pins as possible. No load current may be drawn from the VCOM1/2 pins. All signals, especially clocks, should be kept away from the VCOM1/2 pins in order to avoid unwanted coupling into the AK5388.

## 3. Analog Inputs

The Analog input signal is differentially supplied into the modulator via the LIN+ (RIN+) and the LIN- (RIN-) pins. The input voltage is the difference between the LIN+ (RIN+) and LIN- (RIN-) pins. The full scale signal on each pin is nominally  $\pm 2.8V_{pp}$ (typ). The AK5388 can accept input voltages from VSS1-6 to AVDD1/2. The ADC output data format is two's complement. The internal HPF removes DC offset.

The AK5388 samples the analog inputs at 128fs (6.144MHz@fs=48kHz, Normal Speed Mode). The digital filter rejects noise above the stop band except for multiples of 128fs. The AK5388 includes an anti-aliasing filter (RC filter) to attenuate a noise around 128fs.

The AK5388 requires a +5V analog supply voltage. Any voltage which exceeds the upper limit of AVDD1/2+0.3V and lower limit of VSS1-6 - 0.3V and any current beyond 10mA for the analog input pins (LIN+/-, RIN+/-) should be avoided. Excessive currents to the input pins may damage the device. Hence input pins must be protected from signals at or beyond these limits. Use caution especially when using  $\pm 15V$  for other analog circuits in the system.

4. External Analog Circuit Examples

Figure 23 shows an input buffer circuit example 1. (1<sup>st</sup> order HPF;  $f_c=0.70\text{Hz}$ , 2<sup>nd</sup> order LPF;  $f_c=351\text{kHz}$ , gain=-14.5dB). The analog signal is able to input through XLR or BNC connectors. (short JP1 and JP2 for BNC input, open JP1 and JP2 for XLR input). The input level of this circuit is +/-15.0Vpp (AK5388: +/-2.8Vpp Typ.). When using this circuit, analog characteristics at  $f_s=48\text{kHz}$  is  $\text{DR}=120\text{dB}$ ,  $\text{S}/(\text{N}+\text{D})=110\text{dB}$ .

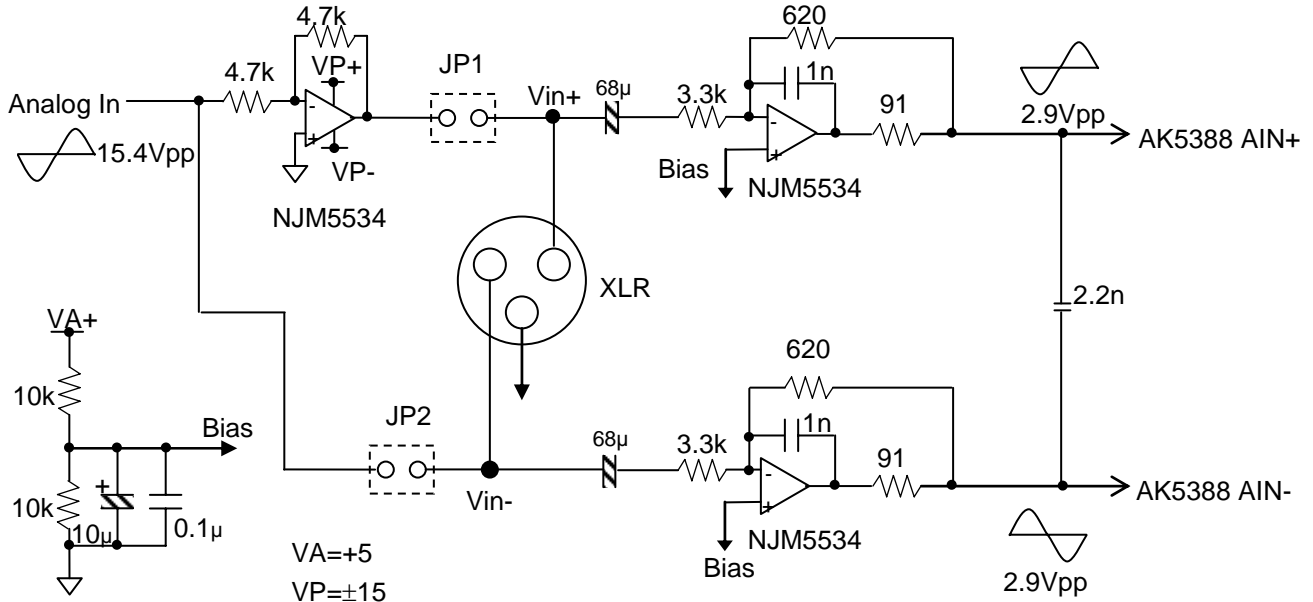

Figure 23. Input Buffer example1

$f_{in}$	1Hz	10Hz
Frequency Response	-1.77dB	-0.02dB

Table 8. Frequency Response of HPF

$f_{in}$	20kHz	40kHz	80kHz	6.144MHz
Frequency Response	0.00dB	0.00dB	0.00dB	-49.68dB

Table 9. Frequency Response of LPF

Figure 24 shows an input buffer circuit example in Mono mode. (1<sup>st</sup> order HPF;  $f_c=0.70\text{Hz}$ , 2<sup>nd</sup> order LPF;  $f_c=351\text{kHz}$ , gain=-14.5dB).

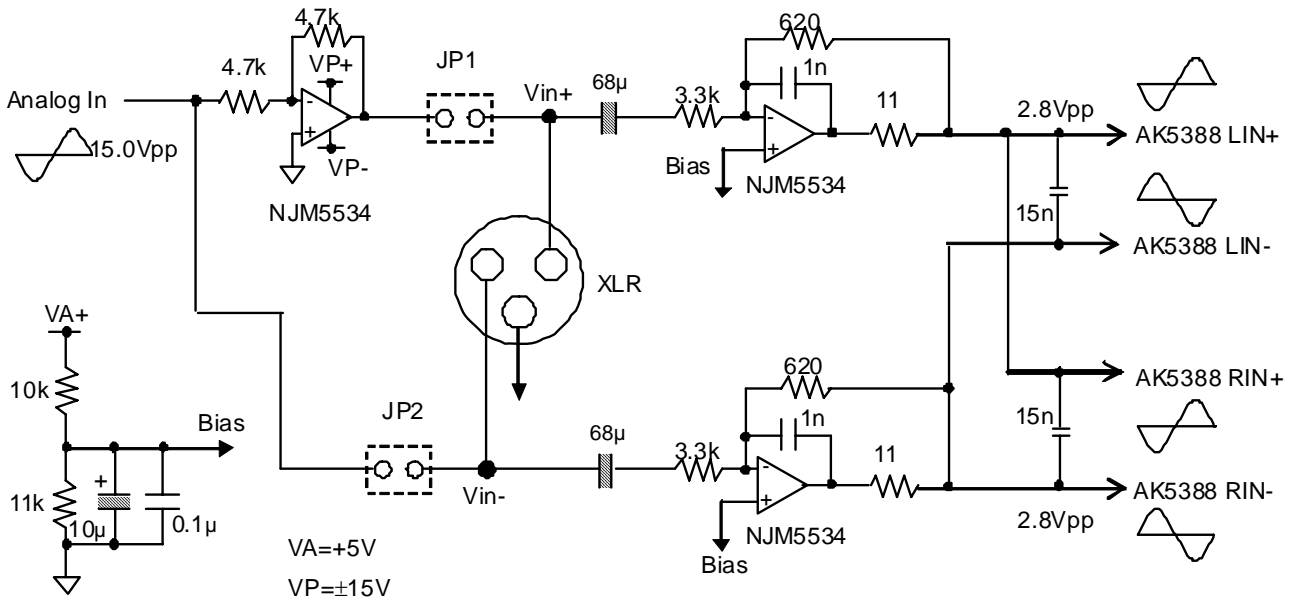

Figure 24 External Analog Circuit Examples

$f_{in}$	1Hz	10Hz
Frequency Response	-1.77dB	-0.02dB

Table 10. Frequency Response of HPF

$f_{in}$	20kHz	40kHz	80kHz	6.144MHz
Frequency Response	0.00dB	0.00dB	0.00dB	-49.68dB

Table 11. Frequency Response of LPF

## 5. Performance Plot

Figure 25 shows a FFT measurement result.

[Conditions]

Ta=25°C; AVDD1/2=5.0V; VREFP1/2=5.0V, VREFL1/2=0V, DVDD=3.3V; VSS1=VSS2=VSS3=VSS4=0V;  
fs=48kHz; Signal Frequency =1kHz, -1dBFS, Measured by Audio Precision, System Two.

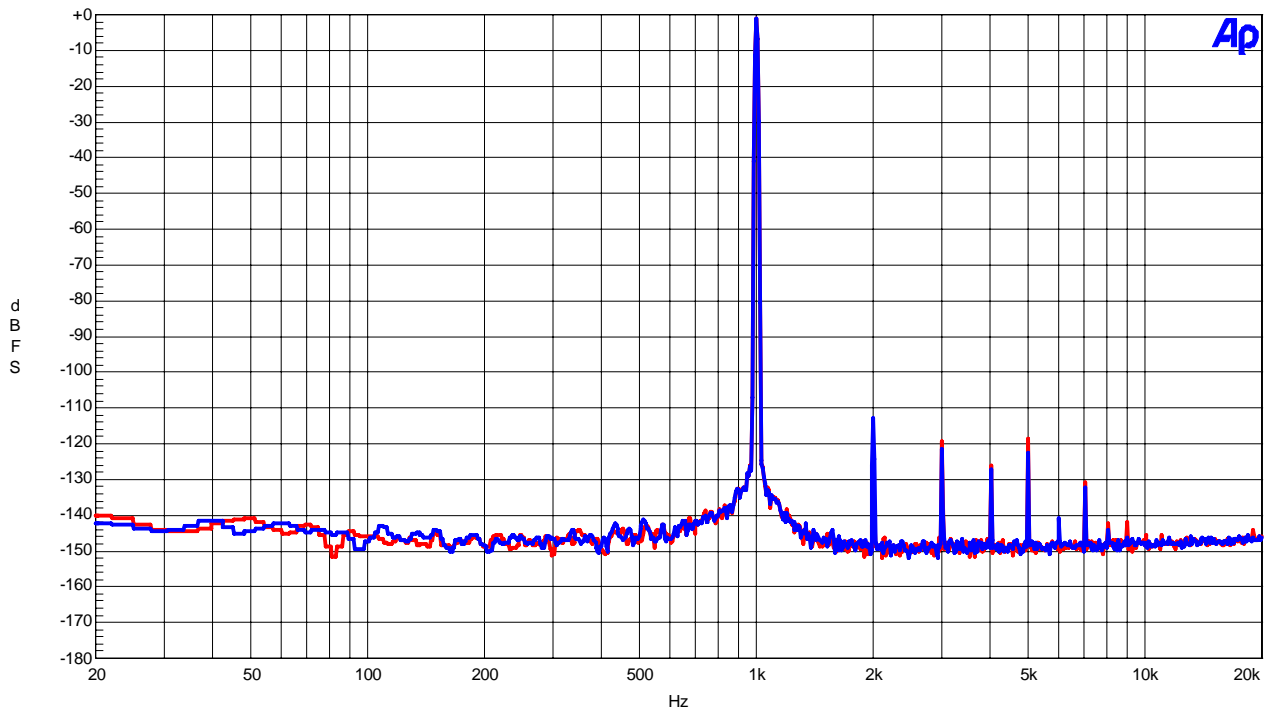
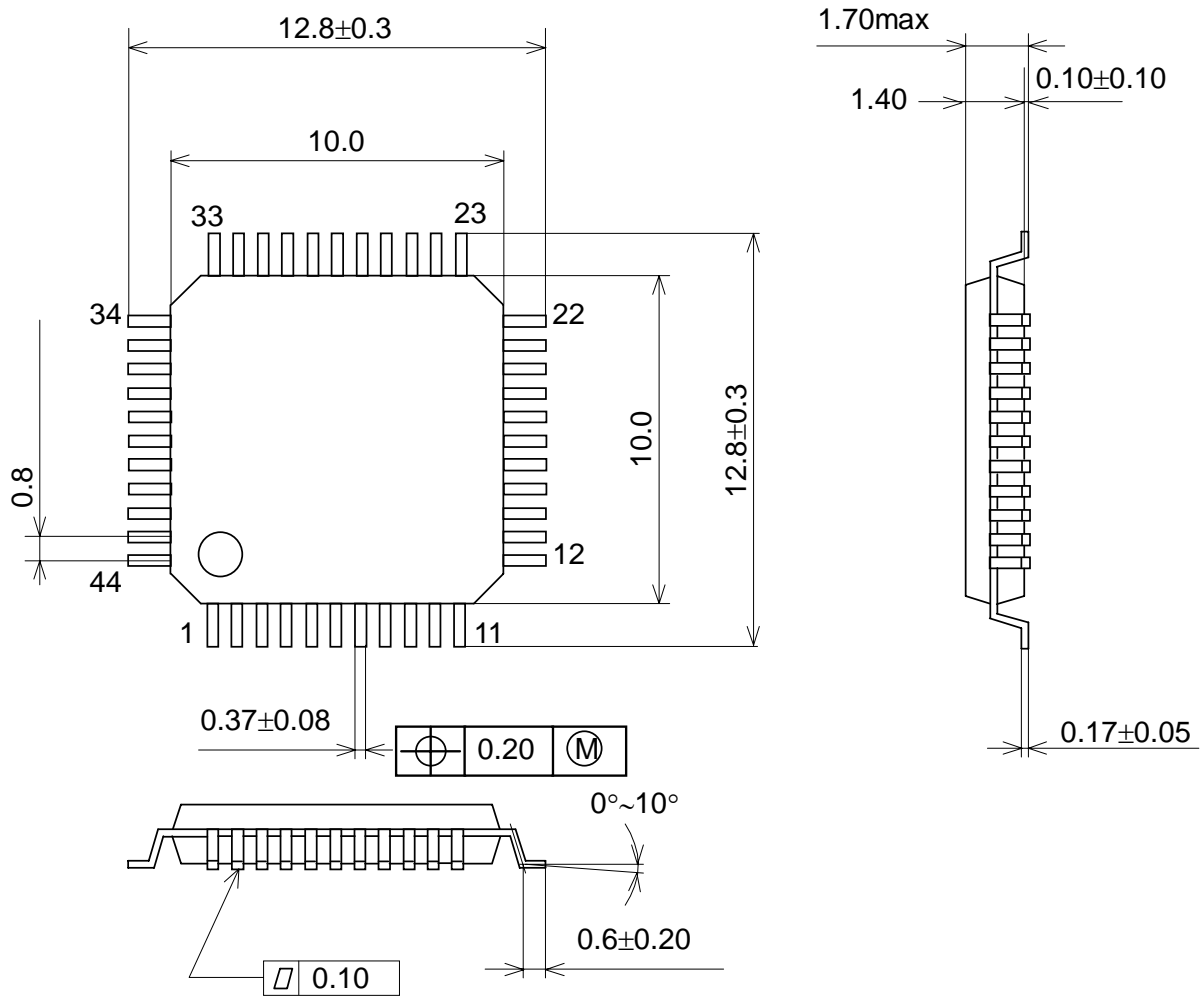

Figure 25. FFT (Blue: Left Channel, Red: Right Channel)

PACKAGE

44pin LQFP (Unit: mm)



■ Material & Lead finish

Package molding compound:	Epoxy
Lead frame material:	Cu
Lead frame surface treatment:	Solder (Pb free) plate

**MARKING**

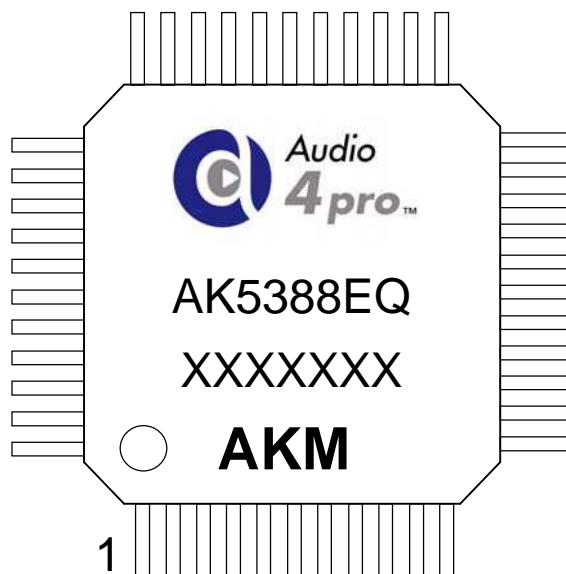

- 1) Pin #1 indication
- 2) Audio 4 pro Logo
- 3) Date Code: XXXXXXXX(7 digits)
- 4) Marking Code: AK5388
- 5) AKM Logo

**REVISION HISTORY**

Date (YY/MM/DD)	Revision	Reason	Page	Contents
09/07/09	00	First Edition		
09/08/xx	01	Error Correct	1	Pin names of block diagram were changed. VRP1 → VREFP1, VRL1 → VREFL1 VRP2 → VREFP2, VRL2 → VREFL2
			22	<ul style="list-style-type: none"> <li>■ Cascade TDM Mode</li> </ul> Figure 17 and description were corrected. SDTO2 is connected to TDMIN → SDTO1 is connected to TDMIN
			26	Figure 23 A resistor value was corrected. 3.3 → 3.3k
			28	[Conditions] VREFL1/2=5.0V → =0V

IMPORTANT NOTICE

- These products and their specifications are subject to change without notice.  
When you consider any use or application of these products, please make inquiries the sales office of Asahi Kasei Microdevices Corporation (AKM) or authorized distributors as to current status of the products.
- AKM assumes no liability for infringement of any patent, intellectual property, or other rights in the application or use of any information contained herein.
- Any export of these products, or devices or systems containing them, may require an export license or other official approval under the law and regulations of the country of export pertaining to customs and tariffs, currency exchange, or strategic materials.
- AKM products are neither intended nor authorized for use as critical components<sub>Note1)</sub> in any safety, life support, or other hazard related device or system<sub>Note2)</sub>, and AKM assumes no responsibility for such use, except for the use approved with the express written consent by Representative Director of AKM. As used here:
  - Note1) A critical component is one whose failure to function or perform may reasonably be expected to result, whether directly or indirectly, in the loss of the safety or effectiveness of the device or system containing it, and which must therefore meet very high standards of performance and reliability.
  - Note2) A hazard related device or system is one designed or intended for life support or maintenance of safety or for applications in medicine, aerospace, nuclear energy, or other fields, in which its failure to function or perform may reasonably be expected to result in loss of life or in significant injury or damage to person or property.
- It is the responsibility of the buyer or distributor of AKM products, who distributes, disposes of, or otherwise places the product with a third party, to notify such third party in advance of the above content and conditions, and the buyer or distributor agrees to assume any and all responsibility and liability for and hold AKM harmless from any and all claims arising from the use of said product in the absence of such notification.