



AK5366VR

24-Bit 48kHz $\Delta\Sigma$ ADC with Selector/PGA/ALC

GENERAL DESCRIPTION

AK5366VR is a high-performance 24-bit, 48kHz sampling ADC for consumer audio and digital recording applications. Thanks to AKM's Enhanced Dual-Bit modulator architecture, this analog-to-digital converter has an impressive dynamic range of 103dB with a high level of integration. The AK5366VR has a 5-channel stereo input selector, an input Programmable Gain Amplifier with an ALC function. All this integration with high-performance makes the AK5366VR well suited for CD and DVD recording systems.

FEATURES

1. 24bit Stereo ADC
 - 5ch Stereo Inputs Selector
 - Input PGA from +18dB to 0dB, 0.5dB Step
 - Peak Hold Function
 - Auto Level Control (ALC) Circuit
 - Digital HPF for offset cancellation ($f_c=1.0\text{Hz}@f_s=48\text{kHz}$)
 - Digital Attenuator from +8dB to -63dB, Mute
 - Soft Mute
 - Single-end Inputs
 - S/(N+D) : 94dB
 - DR, S/N : 103dB
 - Audio I/F Format : 24bit MSB justified, I²S
2. 3-wire Serial μ P Interface / I²C-Bus
3. Master / Slave Mode
4. Master Clock : 256fs/384fs/512fs
5. Sampling Rate : 32kHz to 48kHz
6. Power Supply
 - AVDD: 4.75 ~ 5.25V (typ. 5.0V)
 - DVDD: 3.0 ~ 5.25V (typ. 3.3V)
 - TVDD: 3.0 ~ 5.25V for input tolerant (typ. 5.0V)
7. Ta = -40 ~ 85°C
8. Package : 48pin LQFP (7mm x 7mm)

■ Block Diagram

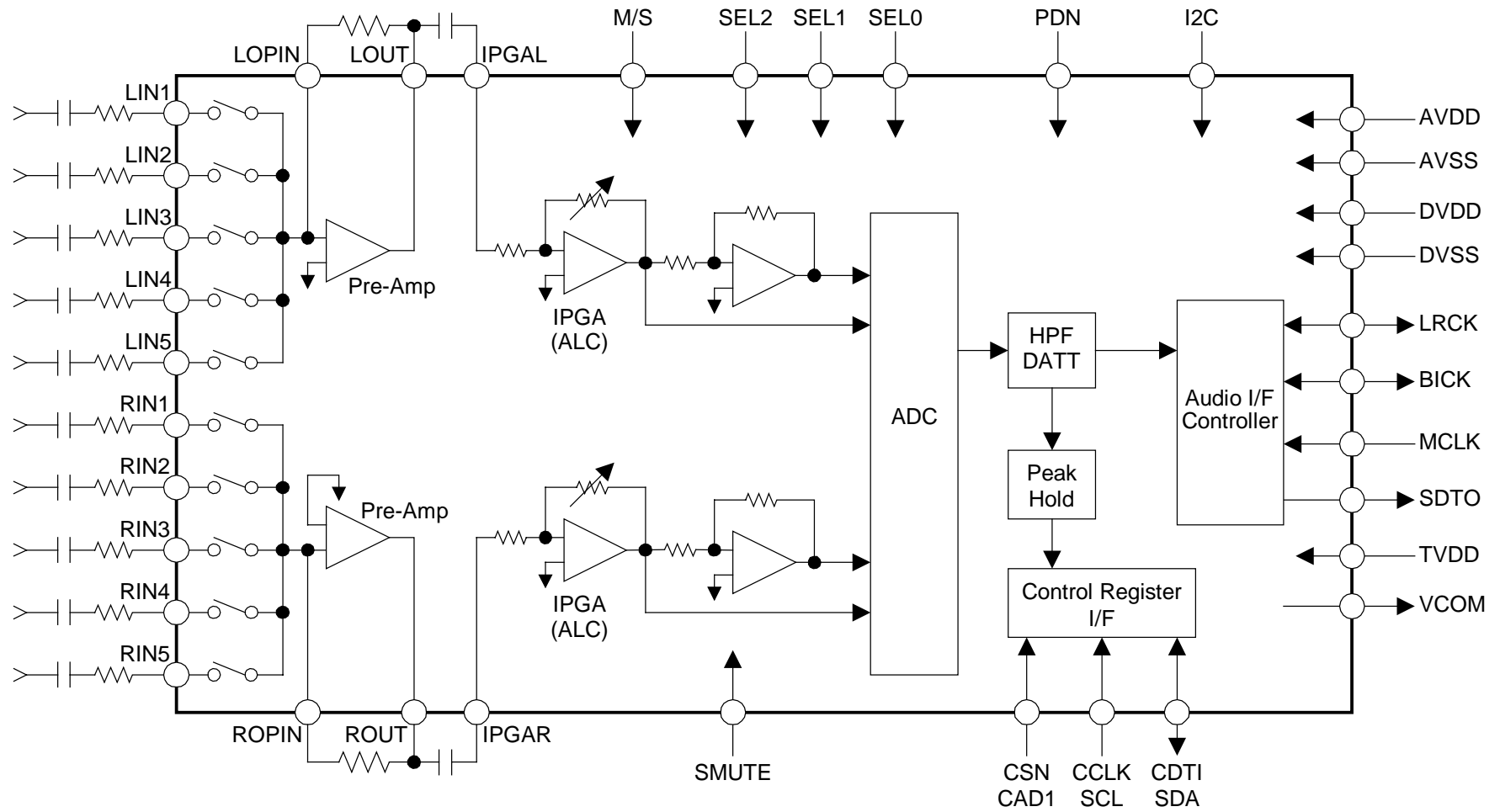

Block diagram

■ Ordering Guide

AK5366VR
AKD5366VR

-40 ~ +85°C

48pin LQFP (0.5mm pitch)

Evaluation Board for AK5366VR

■ Pin Layout

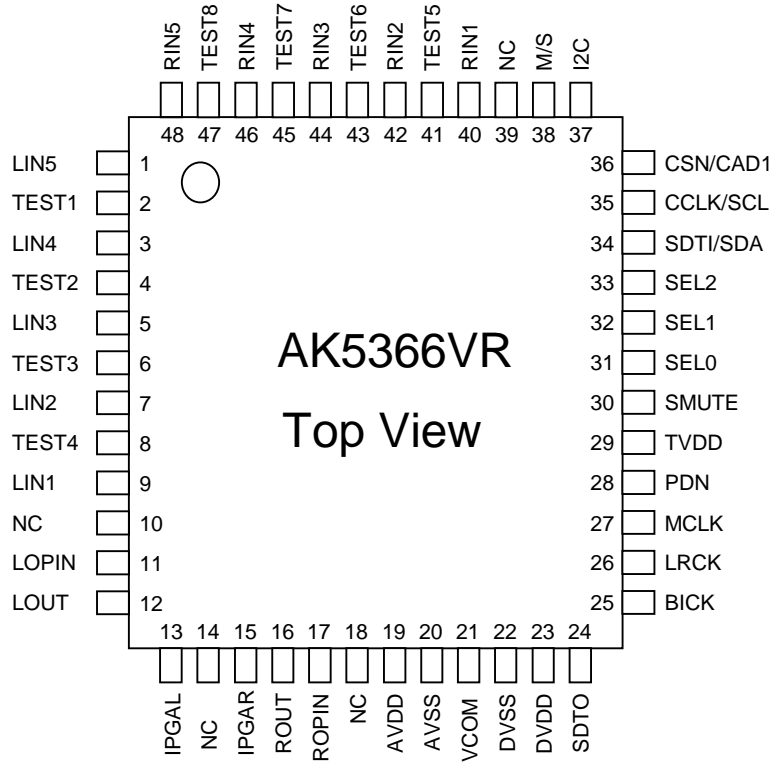

■ Compatibility with AK5365

	AK5365	AK5366	AK5366VR
fs	max. 96kHz	max. 48kHz	←
ALC bit default value	“0” : ALC=OFF	“1” : ALC=ON	←
IPGL/R7-0 default value	“7FH” : 0dB	“80H” : 0dB	←
REF7-0 bit default value	“89H” : +4.5dB	“8EH” : +7.0dB	←
IPGA Gain	0dB ~ +12dB	0dB ~ +18dB	←
DATT Volume	-72dB ~ 0dB	-63dB ~ +8dB	←
MCLK AC Coupling Input	No	Yes	←
Peak Hold Circuit	No	Yes	←
I2C Speed	100kHz	400kHz	←
5V tolerant	No	Yes	←
Package	44pin LQFP	←	48pin LQFP

Software Compatibility

Addr	Register Name	D7	D6	D5	D4	D3	D2	D1	D0
00H	Power Down & Reset Control	0	0	0	0	0	MCKPD	MCKAC	PWN
01H	Input Selector Control	0	0	0	0	0	SEL2	SEL1	SEL0
02H	Clock & Format Control	0	0	0	0	DIF	CKS1	CKS0	SMUTE
03H	Timer Select	0	0	LTM1	LTM0	ZTM1	ZTM0	WTM1	WTM0
04H	Lch IPGA Control	IPGL7	IPGL6	IPGL5	IPGL4	IPGL3	IPGL2	IPGL1	IPGL0
05H	Rch IPGA Control	IPGR7	IPGR6	IPGR5	IPGR4	IPGR3	IPGR2	IPGR1	IPGR0
06H	ALC Mode Control 1	0	0	ZELMN	ALC	FR	LMTH	RATT	LMAT
07H	ALC Mode Control 2	REF7	REF6	REF5	REF4	REF3	REF2	REF1	REF0
08H	Lch DATT Control	ATTL7	ATTL6	ATTL5	ATTL7	ATTL7	ATTL7	ATTL7	ATTL0
09H	Rch DATT Control	ATTR7	ATTR6	ATTR5	ATTR4	ATTR3	ATTR2	ATTR1	ATTR0
0AH	Lch Peak Hold Low Byte	PHL7	PHL6	PHL5	PHL4	PHL3	PHL2	PHL1	PHL0
0BH	Lch Peak Hold High Byte	PHL15	PHL14	PHL13	PHL12	PHL11	PHL10	PHL9	PHL8
0CH	Rch Peak Hold Low Byte	PHR7	PHR6	PHR5	PHR4	PHR3	PHR2	PHR1	PHR0
0DH	Rch Peak Hold High Byte	PHR15	PHR14	PHR13	PHR12	PHR11	PHR10	PHR9	PHR8

: Changing points from AK5365's register.

PIN/FUNCTION			
No.	Pin Name	I/O	Function
1	LIN5	I	Lch Analog Input 5 Pin
2	TEST1	I	Test 1 Pin This pin should be connected to AVSS.
3	LIN4	I	Lch Analog Input 4 Pin
4	TEST2	I	Test 2 Pin This pin should be connected to AVSS.
5	LIN3	I	Lch Analog Input 3 Pin
6	TEST3	I	Test 3 Pin This pin should be connected to AVSS.
7	LIN2	I	Lch Analog Input 2 Pin
8	TEST4	I	Test 4 Pin This pin should be connected to AVSS.
9	LIN1	I	Lch Analog Input 1 Pin
10	NC	-	No internal bonding. Connect to GND.
11	LOPIN	I	Lch Feedback Resistor Input Pin
12	LOUT	O	Lch Feedback Resistor Output Pin
13	IPGAL	I	Lch IPGA Input Pin
14	NC	-	No internal bonding. Connect to GND.
15	IPGAR	I	Rch IPGA Input Pin
16	ROUT	O	Rch Feedback Resistor Output Pin
17	ROPIN	I	Rch Feedback Resistor Input Pin
18	NC	-	No internal bonding. Connect to GND.
19	AVDD	-	Analog Power Supply Pin, 4.75 ~ 5.25V
20	AVSS	-	Analog Ground Pin
21	VCOM	O	Common Voltage Output Pin, AVDD/2 Bias voltage of ADC input.
22	DVSS	-	Digital Ground Pin
23	DVDD	-	Digital Power Supply Pin, 3.0 ~ 5.25V
24	SDTO	O	Audio Serial Data Output Pin

Note: All digital input pins except pull-down pins should not be left floating.

Note: TEST1, TEST2, TEST3 and TEST4 pins should be connected to AVSS.

No.	Pin Name	I/O	Function
25	BICK	I/O	Audio Serial Data Clock Pin
26	LRCK	I/O	Output Channel Clock Pin
27	MCLK	I	Master Clock Input Pin
28	PDN	I	Power-Down Mode Pin “H”: Power up, “L”: Power down reset and initializes the control register.
29	TVDD	-	Input Buffer Power Supply Pin, 3.0 ~ 5.25V
30	SMUTE	I	Soft Mute Pin (Internal Pull-down Pin, typ. 100kΩ) “H” : Soft Mute, “L” : Normal Operation
31	SEL0	I	Input Selector 0 Pin
32	SEL1	I	Input Selector 1 Pin
33	SEL2	I	Input Selector 2 Pin
34	CDTI	I	Control Data Input Pin in 3-wire Control (I2C pin = “L”)
	SDA	I/O	Control Data Input / Output Pin in I ² C Control (I2C pin = “H”)
35	CCLK	I	Control Data Clock Pin in 3-wire Control (I2C pin = “L”)
	SCL	I	Control Data Clock Pin in I ² C Control (I2C pin = “H”)
36	CSN	I	Chip Select Pin in 3-wire Control (I2C pin = “L”)
	CAD1	I	Chip Address 1 Select Pin in I ² C Control (I2C pin = “H”)
37	I2C	I	Control Mode Pin “H” : I ² C Control, “L” : 3-wire Control
38	M/S	I	Master / Slave Mode Pin “H” : Master Mode, “L” : Slave Mode
39	NC	-	No internal bonding. Connect to GND.
40	RIN1	I	Rch Analog Input 1 Pin
41	TEST5	I	Test 5 Pin This pin should be connected to AVSS.
42	RIN2	I	Rch Analog Input 2 Pin
43	TEST6	I	Test 6 Pin This pin should be connected to AVSS.
44	RIN3	I	Rch Analog Input 3 Pin
45	TEST7	I	Test 7 Pin This pin should be connected to AVSS.
46	RIN4	I	Rch Analog Input 4 Pin
47	TEST8	I	Test 8 Pin This pin should be connected to AVSS.
48	RIN5	I	Rch Analog Input 5 Pin

Note: All digital input pins except pull-down pins should not be left floating.

Note: TEST5, TEST6, TEST7 and TEST8 pins should be connected to AVSS.

■ Handling of Unused Pin

The unused input pins should be processed appropriately as below.

Classification	Pin Name	Setting
Analog	LIN1-5 RIN1-5 IPGAL IPGAR	These pins should be open.
	LOPIN/LOUT ROPIN/ROUT	Connected 10kΩ resistor between LOPIN pin and LOUT pin. Connected 10kΩ resistor between ROPIN pin and ROUT pin.
Digital	SMUTE SEL2-0 CSN CCLK/SCL CDTI/SDA I2C	These pins should be connected to DVSS.

ABSOLUTE MAXIMUM RATINGS

(AVSS, DVSS=0V; Note 1)

Parameter		Symbol	min	max	Units
Power Supplies:	Analog	AVDD	-0.3	6.0	V
	Digital	DVDD	-0.3	6.0	V
	Input Buffer (Note 2)	TVDD	-0.3	6.0	V
	AVSS - DVSS (Note 3)	ΔGND	-	0.3	V
Input Current, Any Pin Except Supplies		IIN	-	±10	mA
Analog Input Voltage (Note 4) (LIN1-5, RIN1-5, LOPIN, ROPIN, IPGAL, IPGAR, M/S pins)		VINA	-0.3	AVDD+0.3	V
Digital Input Voltage 1 (MCLK, BICK, LRCK, PDN pins)		VIND1	-0.3	DVDD+0.3	V
Digital Input Voltage 2 (SMUTE, SEL2-0, CSN/CAD1, CCLK/SCL, CDTI/SDA, I2C pins)		VIND2	-0.3	TVDD+0.3	V
Ambient Temperature (Powered applied)		Ta	-40	85	°C
Storage Temperature		Tstg	-65	150	°C

Note 1. All voltages with respect to ground.

Note 2. SMUTE, SEL2-0, CSN/CAD1, CCLK/SCL, CDTI/SDA and I2C pins correspond to 5V tolerant.

Note 3. AVSS and DVSS must be connected to the same analog ground plane.

Note 4. M/S pin is the digital input pin. However, M/S pin should be connected to AVDD or AVSS to prevent the noise to the analog input pins

WARNING: Operation at or beyond these limits may result in permanent damage to the device.

Normal operation is not guaranteed at these extremes.

RECOMMENDED OPERATING CONDITIONS

(AVSS, DVSS=0V; Note 1)

Parameter		Symbol	min	typ	max	Units
Power Supplies (Note 5)	Analog	AVDD	4.75	5.0	5.25	V
	Digital	DVDD	3.0	3.3	AVDD	V
	Input Buffer	TVDD	DVDD	5.0	AVDD	V

Note 1. All voltages with respect to ground.

Note 5. The power up sequence between AVDD, DVDD and TVDD is not critical.

WARNING: AKM assumes no responsibility for the usage beyond the conditions in this datasheet.

ANALOG CHARACTERISTICS

(Ta=25°C; AVDD=TVDD=5.0V, DVDD=3.3V; AVSS=DVSS=0V; fs=48kHz; BICK=64fs;

Signal Frequency=1kHz; 24bit Data; Measurement frequency=20Hz ~ 20kHz at fs=48kHz; unless otherwise specified)

Parameter	min	typ	max	Units
Pre-Amp Characteristics:				
Feedback Resistance	10		50	kΩ
S/(N+D) (Note 6)	-	100		dB
S/N (A-weighted) (Note 6)	-	108		dB
Load Resistance (Note 7)	6.3			kΩ
Load Capacitance			20	pF
Input PGA Characteristics:				
Input Voltage (Note 8)	0.9	1	1.1	Vrms
Input Resistance (Note 9)	6.3	10	15	kΩ
Step Size	0.2	0.5	0.8	dB
Gain Control Range	ALC = OFF	0	+18	dB
	ALC = ON	-9.5	+18	dB
ADC Analog Input Characteristics: IPGA=0dB, ALC = OFF (Note 10)				
Resolution			24	Bits
S/(N+D) (-0.5dBFS)	84	94		dB
DR (-60dBFS, A-weighted)	96	103		dB
S/N (A-weighted)	96	103		dB
Interchannel Isolation (Note 11)	90	110		dB
Interchannel Gain Mismatch		0.2	0.5	dB
Gain Drift		100	-	ppm/°C
Power Supply Rejection (Note 12)		50	-	dB
Power Supplies				
Power Supply Current				
Normal Operation (PDN pin = "H")				
AVDD		23	35	mA
DVDD+TVDD		4	8	mA
Power-down mode (PDN pin = "L") (Note 13)				
AVDD		10	100	μA
DVDD+TVDD		10	100	μA

Note 6. This value is measured at LOUT and ROUT pins using the circuit as shown in Figure 25.

The input signal voltage is 2Vrms.

Note 7. This value is the input impedance of an external device that the LOUT and ROUT pins can drive, when a device is

connected with LOUT and ROUT pin externally. The feedback resistor (min. 10kΩ) that it is usually connected with the LOUT/ROUT pins, and the value of input impedance (min. 6.3kΩ) of the IPGAL/R pins are not included.

Note 8. Full scale (0dB) of the input voltage at ALC=OFF and IPGA=0dB.

Input voltage to IPGAL and IPGAR pins is proportional to AVDD voltage. typ. Vin = 0.2 x AVDD (Vrms).

Note 9. This value is input impedance of the IPGAL and IPGAR pins.

Note 10. This value is measured via the following path. Pre-Amp → IPGA (Gain : 0dB) → ADC.

The measurement circuit is Figure 25.

Note 11. This value is the interchannel isolation between all the channels of the LIN1-5 and RIN1-5 when the applied input

signal causes the Pre-Amp output to equal IPGA input.

Note 12. PSR is applied to AVDD, DVDD and TVDD with 1kHz, 50mVpp.

Note 13. All digital input pins are held DVSS.

FILTER CHARACTERISTICS

(Ta=-40 ~ 85°C; AVDD=4.75 ~ 5.25V; DVDD, TVDD=3.0 ~ 5.25V; fs=48kHz)

Parameter	Symbol	min	typ	max	Units
ADC Digital Filter (Decimation LPF):					
Passband (Note 14)	-0.005dB	PB	0	21.5	kHz
	-0.02dB		-	21.768	kHz
	-0.06dB		-	22.0	kHz
	-6.0dB		-	24.0	kHz
Stopband	SB	26.5			kHz
Passband Ripple	PR			±0.005	dB
Stopband Attenuation	SA	80			dB
Group Delay (Note 15)	GD		31		1/fs
Group Delay Distortion	ΔGD		0		μs
ADC Digital Filter (HPF):					
Frequency Response (Note 14)	-3dB	FR		1.0	Hz
	-0.5dB			2.9	Hz
	-0.1dB			6.5	Hz

Note 14. The passband and stopband frequencies scale with fs. For example, 21.768kHz at -0.02dB is 0.454 x fs.

Note 15. The calculated delay time induced by digital filtering. This time is from the input of an analog signal to the setting of 24bit data both channels to the ADC output register for ADC.

DC CHARACTERISTICS

(Ta=-40 ~ 85°C; AVDD=4.75 ~ 5.25V; DVDD, TVDD=3.0 ~ 5.25V)

Parameter	Symbol	min	typ	max	Units
High-Level Input Voltage (Note 16)	VIH	70% DVDD	-		V
Low-Level Input Voltage (Note 16)	VIL	-	-	30% DVDD	V
Input Voltage at AC Coupling (Note 17)	VAC	50% DVDD	-	-	V
High-Level Output Voltage (Iout=-400μA)	VOH	DVDD-0.5	-	-	V
Low-Level Output Voltage (Except SDA pin : Iout=400μA)	VOL	-	-	0.5	V
	VOL	-	-	0.4	V
(SDA pin : Iout=3mA)					
Input Leakage Current (Note 18)	Iin	-	-	±10	μA

Note 16. SMUTE, SEL2-0, CSN/CAD1, CCLK/SCL, CDTI/SDA and I2C pins correspond to 5V tolerant.

Note 17. When AC coupled capacitor is connected to MCLK pin.

Note 18. SMUTE pin is internally connected to a pull-down resistor. (typ. 100kΩ)

SWITCHING CHARACTERISTICS

(Ta=-40 ~ 85°C; AVDD=4.75 ~ 5.25V; DVDD, TVDD=3.0 ~ 5.25V; C_L=20pF)

Parameter	Symbol	min	typ	max	Units
Master Clock Timing					
Frequency	fCLK	8.192		24.576	MHz
Pulse Width Low	tCLKL	0.3/fCLK			ns
Pulse Width High	tCLKH	0.3/fCLK			ns
AC Pulse Width (Note 19)	tACW	0.4/fCLK			ns
LRCK Frequency					
Frequency	fsn	32		48	kHz
Duty Cycle	Slave mode	45		55	%
	Master mode		50		%
Audio Interface Timing					
Slave mode					
BICK Period	tBCK	160			ns
BICK Pulse Width Low	tBCKL	65			ns
Pulse Width High	tBCKH	65			ns
LRCK Edge to BICK “↑” (Note 20)	tLRB	30			ns
BICK “↑” to LRCK Edge (Note 20)	tBLR	30			ns
LRCK to SDTO (MSB) (Except I ² S mode)	tLRS			35	ns
BICK “↓” to SDTO	tBSD			35	ns
Master mode					
BICK Frequency	fBCK		64fs		Hz
BICK Duty	dBCK		50		%
BICK “↓” to LRCK	tMBLR	-20		20	ns
BICK “↓” to SDTO	tBSD	-20		35	ns

Note 19. Pulse width to ground level when MCLK is connected to a capacitor in series and a resistor is connected to ground.

Note 20. BICK rising edge must not occur at the same time as LRCK edge.

Parameter	Symbol	min	typ	max	Units
Control Interface Timing (3-wire Serial mode):					
CCLK Period	tCCK	200			ns
CCLK Pulse Width Low	tCCKL	80			ns
Pulse Width High	tCCKH	80			ns
CDTI Setup Time	tCDS	40			ns
CDTI Hold Time	tCDH	40			ns
CSN "H" Time	tCSW	150			ns
CSN "↓" to CCLK "↑"	tCSS	50			ns
CCLK "↑" to CSN "↑"	tCSH	50			ns
Control Interface Timing (I²C Bus mode):					
SCL Clock Frequency	fSCL	-		400	kHz
Bus Free Time Between Transmissions	tBUF	1.3		-	μs
Start Condition Hold Time (prior to first clock pulse)	tHD:STA	0.6		-	μs
Clock Low Time	tLOW	1.3		-	μs
Clock High Time	tHIGH	0.6		-	μs
Setup Time for Repeated Start Condition	tSU:STA	0.6		-	μs
SDA Hold Time from SCL Falling (Note 21)	tHD:DAT	0		-	μs
SDA Setup Time from SCL Rising	tSU:DAT	0.1		-	μs
Rise Time of Both SDA and SCL Lines	tR	-		0.3	μs
Fall Time of Both SDA and SCL Lines	tF	-		0.3	μs
Setup Time for Stop Condition	tSU:STO	0.6		-	μs
Pulse Width of Spike Noise Suppressed by Input Filter	tSP	0		50	ns
Reset Timing					
PDN Pulse Width (Note 22)	tPD	150			ns
PDN "↑" to SDTO valid (Note 23)	tPDV		516		1/fs
CSN "↑" to SDTO valid (Note 24)	tPDV		516		1/fs

Note 21. Data must be held long enough to bridge the 300ns-transition time of SCL.

Note 22. The AK5366VR can be reset by bringing the PDN pin = "L".

Note 23. This cycle is the number of LRCK rising edges from the PDN pin = "H".

Note 24. This cycle is the number of LRCK rising edges from the CSN = "H".

Purchase of Asahi Kasei Microsystems Co., Ltd I²C components conveys a license under the Philips I²C patent to use the components in the I²C system, provided the system conform to the I²C specifications defined by Philips.

■ Timing Diagram

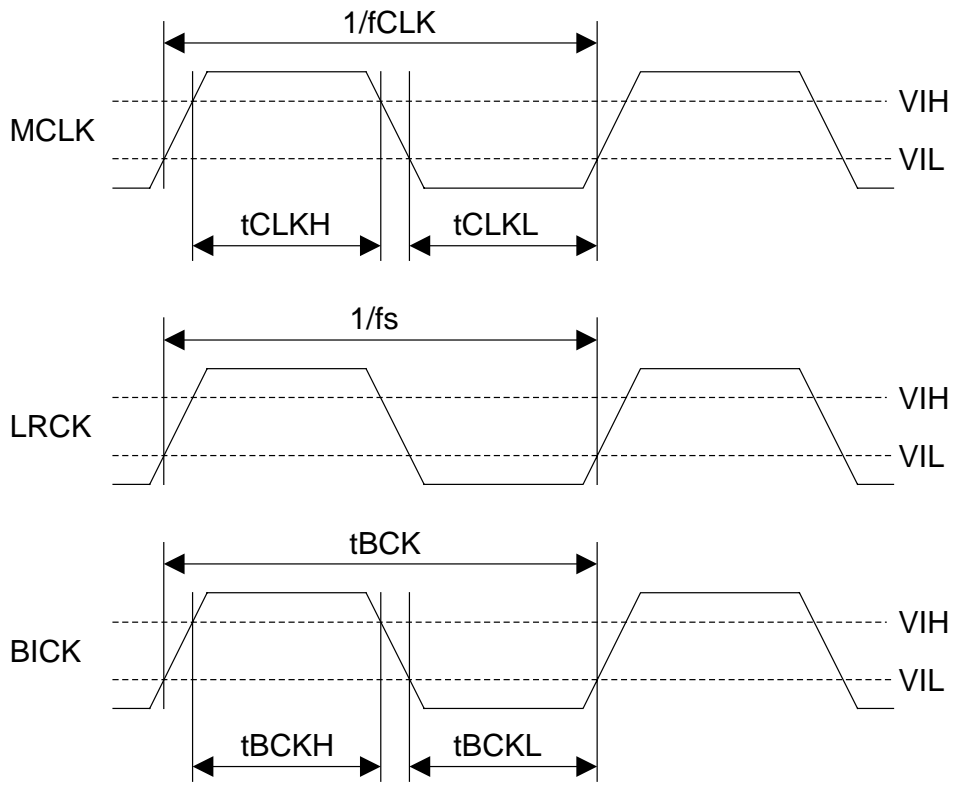

Clock Timing

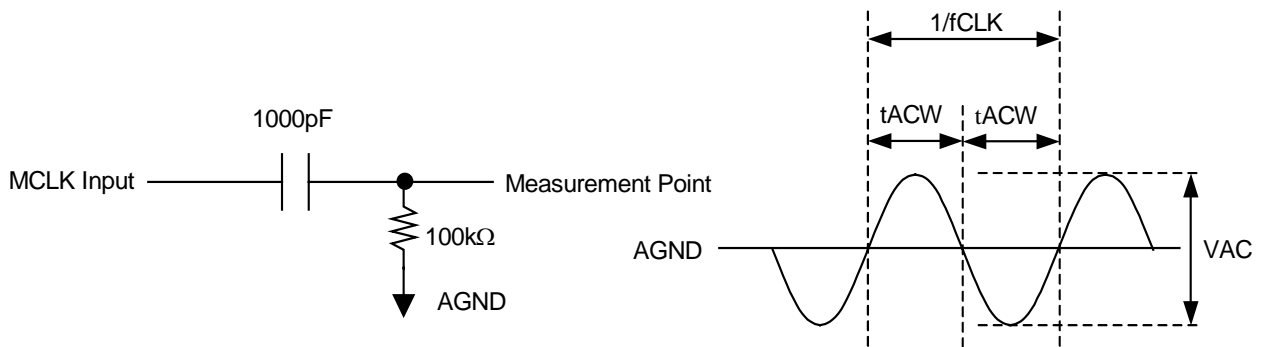

MCLK AC Coupling Timing (Measurement condition)

*Refer to Figure 2 for input circuit example.

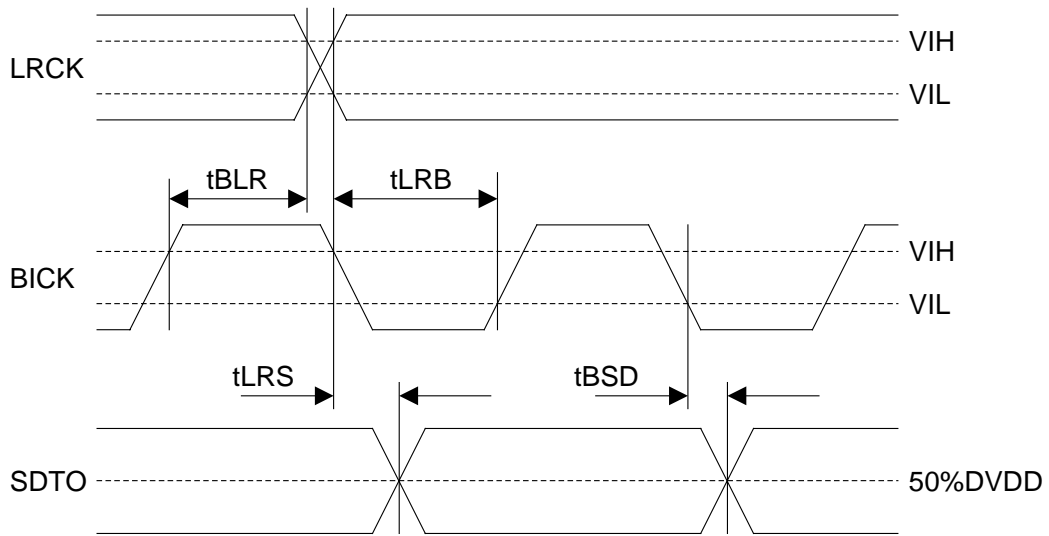

Audio Interface Timing (Slave mode)

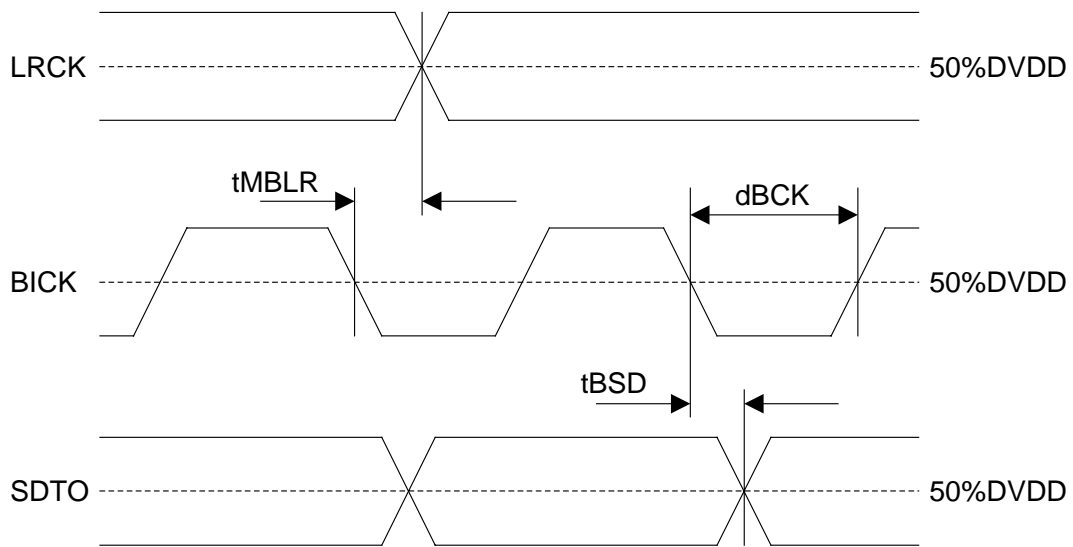

Audio Interface Timing (Master mode)

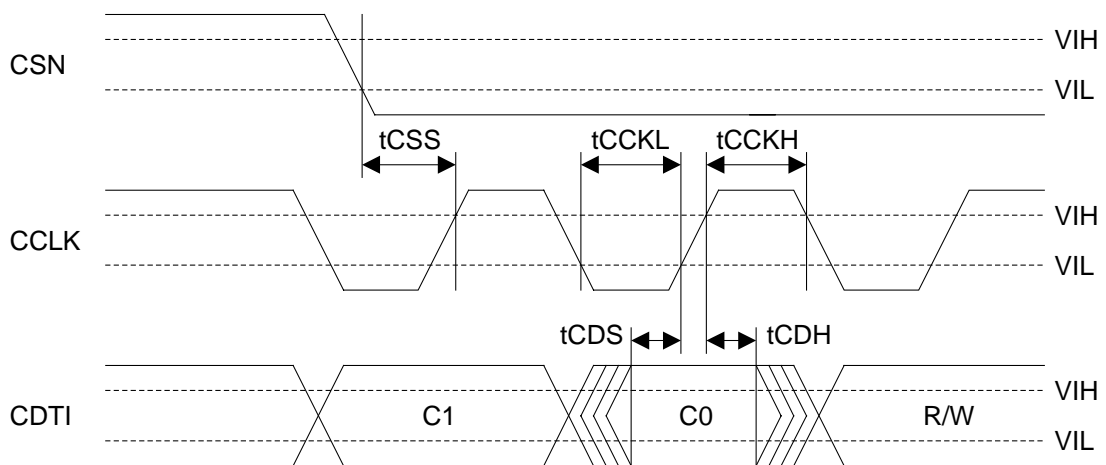

WRITE Command Input Timing

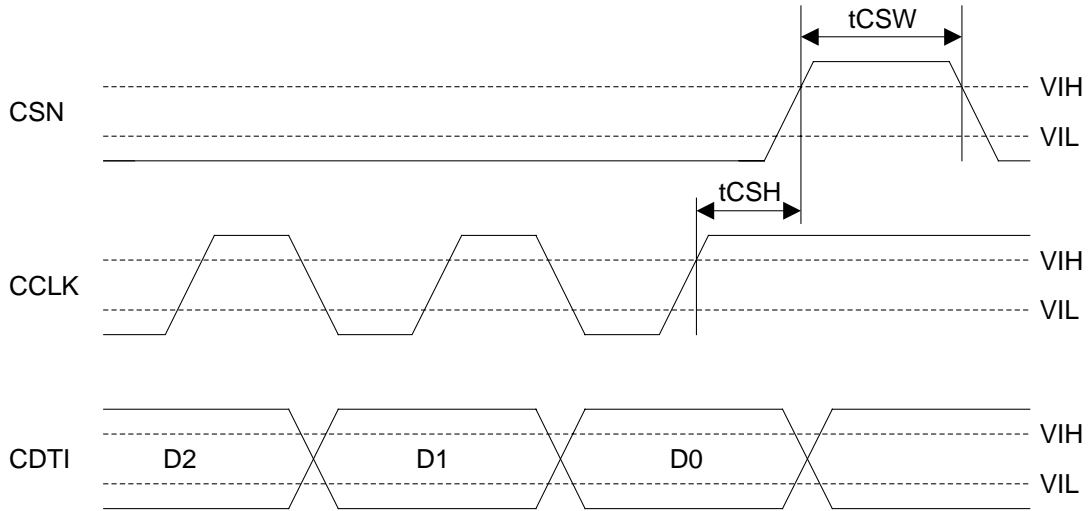

WRITE Data Input Timing

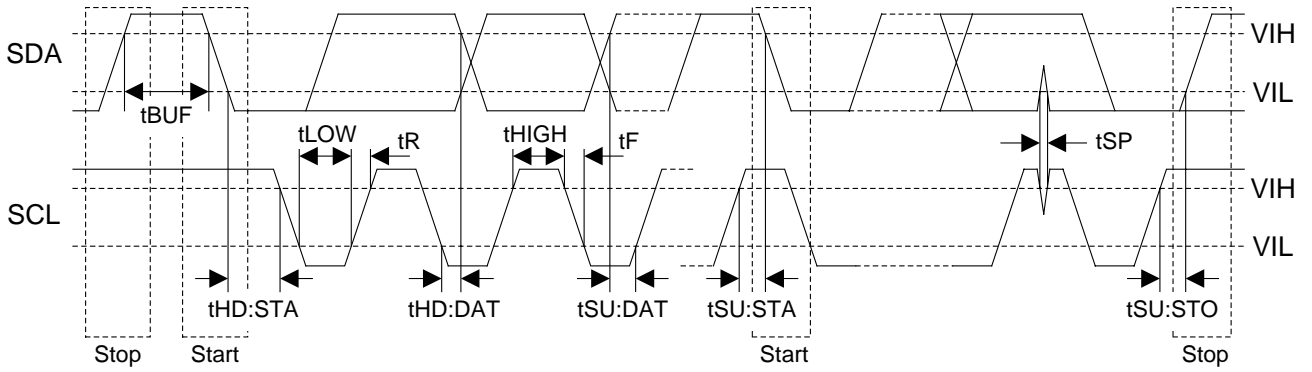

I²C Bus Mode Timing

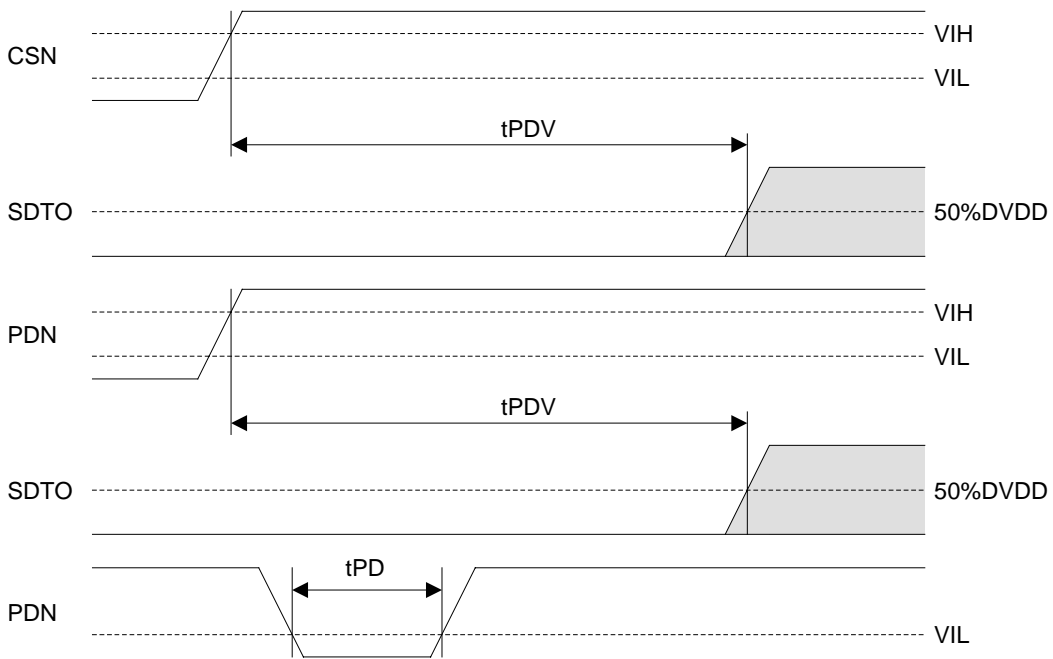

Power Down & Reset Timing

OPERATION OVERVIEW

■ System Clock

MCLK (256fs/384fs/512fs), BICK (48fs~) and LRCK (fs) clocks are required in slave mode. The LRCK clock input must be synchronized with MCLK, however the phase is not critical. MCLK frequency is automatically detected in slave mode. Table 1 shows the relationship of typical sampling frequency and the system clock frequency. Setting of CKS 1-0 bit is ignored.

MCLK (256fs/384fs/512fs) is required in master mode. MCLK frequency is selected by CKS1-0 bits as shown in Table 2. In master mode, after setting CKS1-0 bits, there is a possibility the frequency and duty of LRCK and BICK outputs become an abnormal state.

All external clocks (MCLK, BICK and LRCK) must be present unless PDN pin = “L” and PWN bit = “1”. If these clocks are not provided, the AK5366VR may draw excess current due to its use of internal dynamically refreshed logic. If the external clocks are not present, place the AK5366VR in power-down mode (PDN pin = “L” or PWN bit = “0”). In master mode, the master clock (MCLK) must be provided unless PDN pin = “L”.

fs	MCLK		
	256fs	384fs	512fs
32kHz	8.192MHz	12.288MHz	16.384MHz
44.1kHz	11.2896MHz	16.9344MHz	22.5792MHz
48kHz	12.288MHz	18.432MHz	24.576MHz

Table 1. System clock example (Slave mode)

CKS1	CKS0	MCLK	Default
0	0	256fs	
0	1	512fs	
1	0	384fs	
1	1	N/A	

Table 2. Master clock frequency select (Master mode)

[MCLK AC Coupling input]

MCLK AC coupling input becomes possible by controlling MCKPD bit and MCKAC bit.

Master Clock	Status	MCKAC bit	MCKPD bit
External Clock Direct Input (Figure 1)	Clock is input to MCLK pin.	0	0
	Clock isn't input to MCLK pin.	0	Don't care
AC Coupling Input (Figure 2)	Clock is input to MCLK pin.	1	0
	Clock isn't input to MCLK pin.	1	1

Table 3. MCKPD bit and MCKAC bit setting for Master Clock Status

(1) External clock direct input

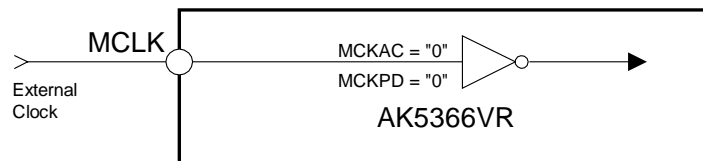

Figure 1. External Master Clock Input Block

(2) AC coupling input

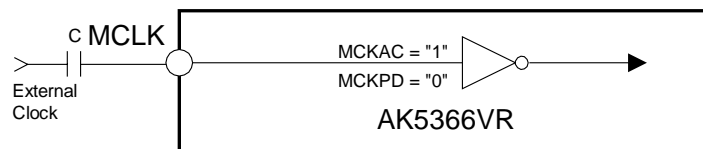

Figure 2. External Clock mode (Input : $\geq 50\%DVDD$, Input circuit example)
 - Note: This clock level must not exceed DVDD level. (C : 0.1 μ F)

■ Audio Interface Format

Two kinds of data formats can be chosen with the DIF bit (Table 4). In both modes, the serial data is in MSB first, 2's complement format. The SDTO is clocked out on the falling edge of BICK. The audio interface supports both master and slave modes. In master mode, BICK and LRCK are output with the BICK frequency fixed to 64fs and the LRCK frequency fixed to 1fs.

Mode	DIF bit	SDTO	LRCK	BICK	Figure
0	0	24bit, MSB justified	H/L	$\geq 48fs$ (Slave) 64fs (Master)	Figure 3
1	1	24bit, I ² S Compatible	L/H	$\geq 48fs$ (Slave) 64fs (Master)	Figure 4

Default

Table 4. Audio Interface Format

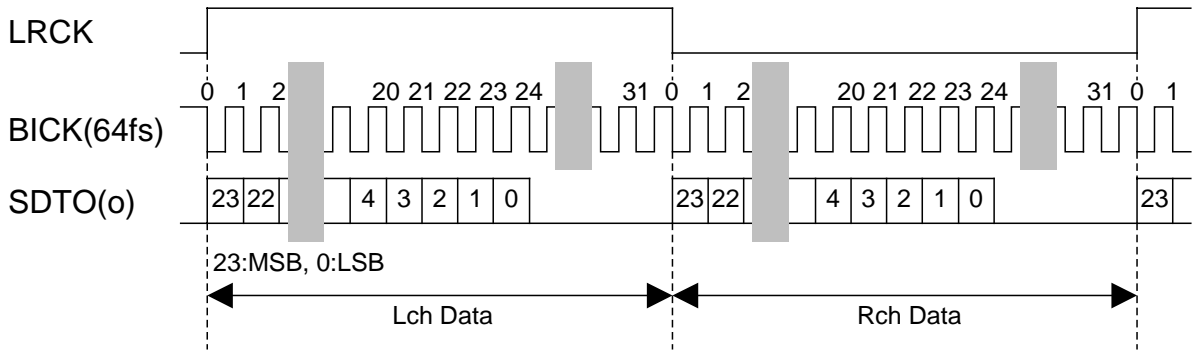

Figure 3. Mode 0 Timing

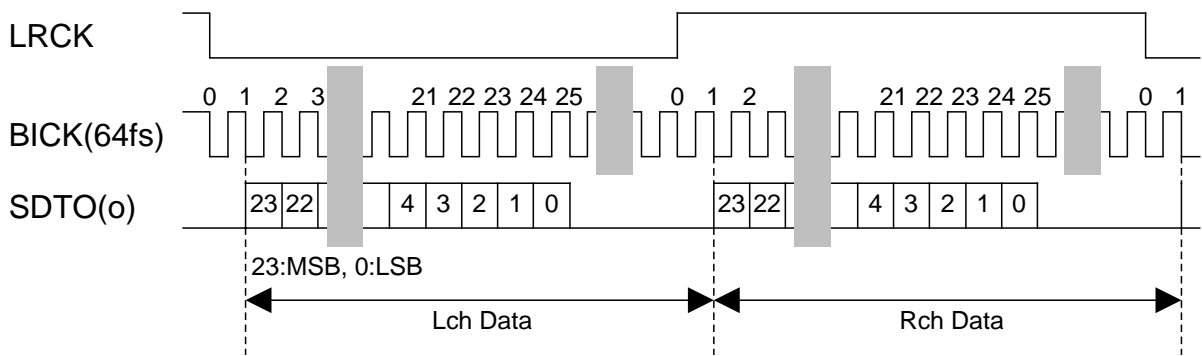

Figure 4. Mode 1 Timing

■ Master Mode and Slave Mode

The M/S pin selects either master or slave mode. M/S pin = “H” selects master mode and “L” selects slave mode. The AK5366VR outputs BICK and LRCK in master mode. In slave mode, MCLK, BICK and LRCK are input externally.

	BICK, LRCK
Slave Mode	BICK = Input LRCK = Input
Master Mode	BICK = Output LRCK = Output

Table 5. Master mode/Slave mode

■ Digital High Pass Filter

The ADC has a digital high pass filter for DC offset cancellation. The cut-off frequency of the HPF is 1.0Hz (@fs=48kHz) and scales with sampling rate (fs).

■ Power-up/down

The AK5366VR is placed in the power-down mode by bringing PDN pin = “L” and the digital filter is also reset at the same time. This reset should always be done after power-up. An analog initialization cycle starts after exiting the power-down mode. Therefore, the output data SDTO becomes available after 516 cycles of LRCK.

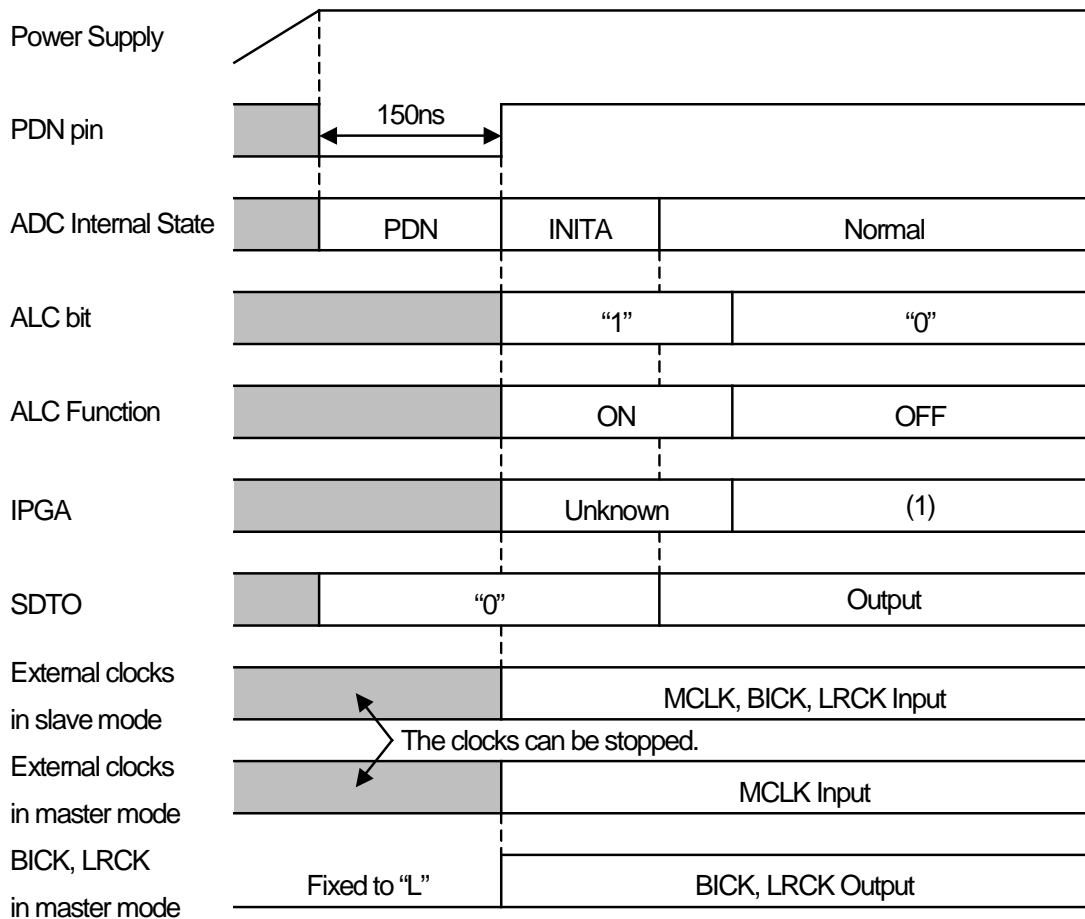

- PDN : Power down state.
- INITA : Initializing period of ADC analog section (516/fs).
- (1) : After ALC operation is disabled, the IPGA changes to the last written data during or before ALC operation.

Figure 5. Power-up Sequence

■ Peak Hold Circuit

The AK5366VR includes the peak hold circuit. The peak is held L/R audio data independently. These registers are reset by reading 8bit of MSB, reading 8bit of both MSB and LSB should be continuity controlled by reading in order of 8bit of MSB from LSB. After reading 8bit of LSB the last, 8bit of MSB is lost by reading 8bit of LSB the last. The output value is the absolute value. Full scale is “FFFFH”.

■ Input Selector

The AK5366VR includes 5ch stereo input selectors (Figure 6). The input selector is 5 to 1 selector. The input channel is set by the SEL2-0 bits (Table 6) and the SEL2-0 pins (Table 7). The SEL2-0 pins should be fixed to “LLL” if the AK5366VR is controlled by the SEL 2-0 bits, because the setting of the SEL2-0 pins are prior to the SEL2-0 bits setting.

SEL2 bit	SEL1 bit	SEL0 bit	Input Channel
0	0	0	LIN1 / RIN1
0	0	1	LIN2 / RIN2
0	1	0	LIN3 / RIN3
0	1	1	LIN4 / RIN4
1	0	0	LIN5 / RIN5

Default

Table 6. Input Selector (SEL2-0 pin = “LLL”)

SEL2 pin	SEL1 pin	SEL0 pin	Input Channel
L	L	L	LIN1 / RIN1
L	L	H	LIN2 / RIN2
L	H	L	LIN3 / RIN3
L	H	H	LIN4 / RIN4
H	L	L	LIN5 / RIN5

Table 7. Input Selector (SEL2-0 bit = “000”)

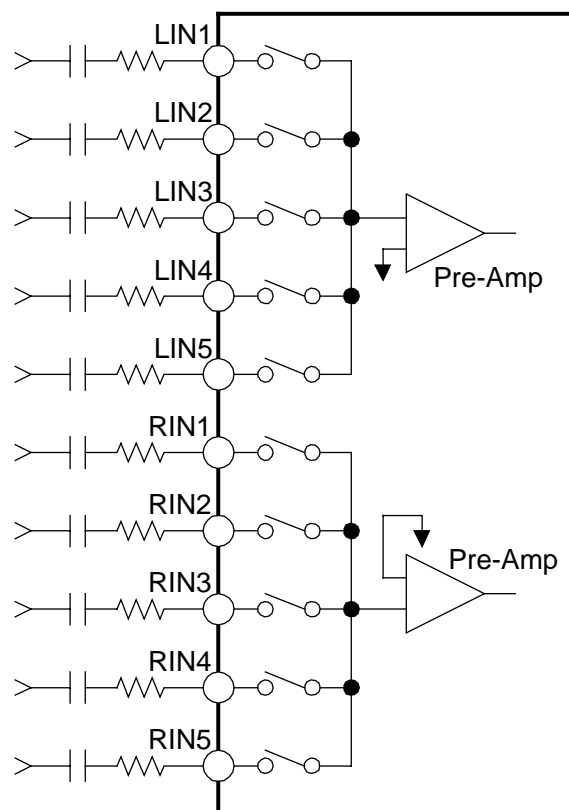

Figure 6. Input Selector

[Input selector switching sequence]

The input selector should be changed after soft mute to avoid the switching noise of the input selector (Figure 7).

1. Enable the soft mute before changing channel.
2. Change channel.
3. Disable the soft mute.

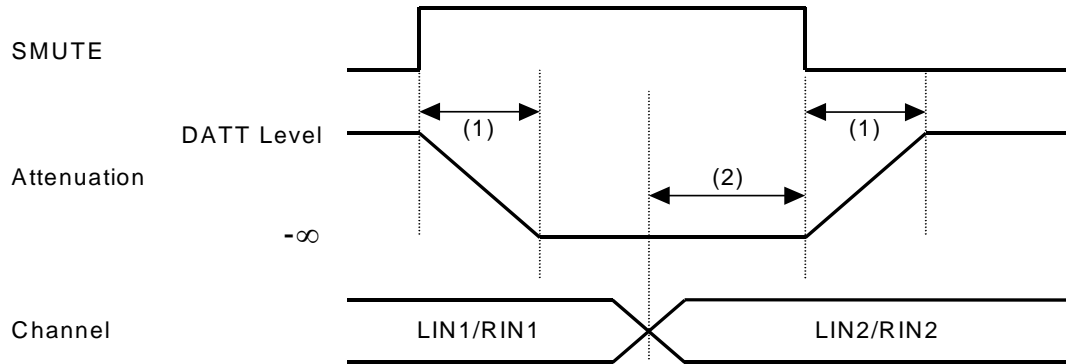

Figure 7. Input channel switching sequence example

The period of (1) varies in the setting value of DATT. It takes 1028/fs to mute when DATT value is +8dB.

When changing channels, the input channel should be changed during (2). The period of (2) should be around 200ms because there is some DC difference between the channels.

■ Input Attenuator

The input ATTs are constructed by adding the input resistor (R_i) for LIN1-5/RIN1-5 pins and the feedback resistor (R_f) between LOPIN (ROPIN) pin and LOOUT (ROUT) pin (Figure 8). The input voltage range of the IPGAL/IPGAR pin is typically $typ. 0.2 \times AVDD$ (Vrms). If the input voltage of the input selector exceeds $typ. 0.2 \times AVDD$, the input voltage of the IPGAL/IPGAR pins must be attenuated to $0.2 \times AVDD$ by the input ATTs. Table 8 shows the example of R_i and R_f .

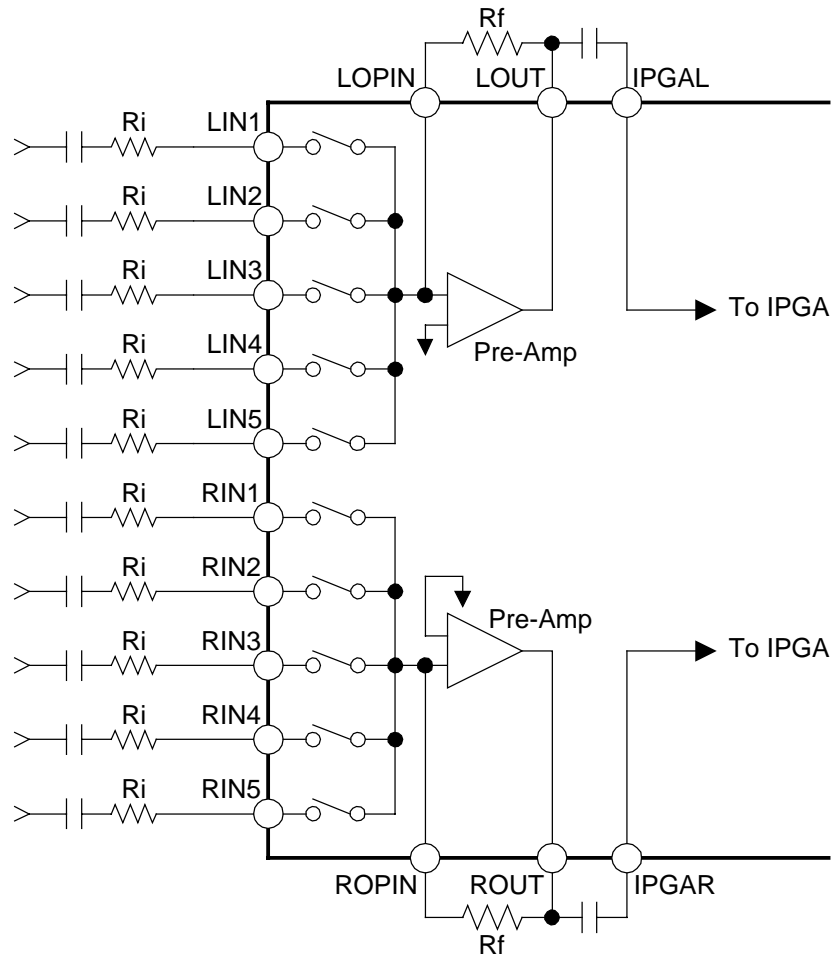

Figure 8. Input ATT

- Example for input range

Input Range	R_i [k Ω]	R_f [k Ω]	ATT Gain [dB]	IPGAL/R pin
4Vrms	47	12	-11.86	1.02Vrms
2Vrms	47	24	-5.84	1.02Vrms
1Vrms	47	47	0	1Vrms

Table 8. Input ATT example

■ Input Volume

The AK5366VR includes two independent channel analog volumes (IPGA) with 37 levels at 0.5dB steps located in front of the ADC.

The IPGA is a true analog volume control that improves the S/N ratio as seen in Table 9. Independent zero-crossing detection is used to ensure level changes only occur during zero-crossings. If there are no zero-crossings, the level will then change after a time-out period (Table 10); the time-out period scales with f_s . If a new value is written to the IPGA register before the IPGA changes at the zero crossing or time-out, the previous value becomes invalid. The timer (channel independent) for time-out is reset and the timer restarts for new IPGA value.

	Input Gain Setting		
	0dB	+6dB	+18dB
$f_s=48\text{kHz}$, A-weight	103dB	100dB	89dB

Table 9. PGA+ADC S/N

ZTM1	ZTM0	Zero crossing timeout period	@ $f_s=48\text{kHz}$	Default
0	0	288/ f_s	6ms	
0	1	1152/ f_s	24ms	
1	0	2304/ f_s	48ms	
1	1	4608/ f_s	96ms	

Table 10. Zero crossing timeout period

[Writing operation at ALC Enable]

Writing to the area over 7FH (Table 17) of IPGL/R registers (04H, 05H) is ignored during ALC operation. After ALC is disabled, the IPGA changes to the last written data by zero-crossing or time-out. In case of writing to the DATT area (08H, 09H), the DATT changes even if ALC is enabled.

■ Output Volume

The AK5366VR includes two independent channel digital volumes (DATT) with 144 levels at 0.5dB steps located behind the ADC. When changing levels, transitions are executed via soft changes; thus no switching noise occurs during these transitions. The data must not be written over 90H.

ATTL/R7-0	Attenuation	Default
8FH	+8.0dB	
8EH	+7.5dB	
:	:	
81H	+1.0dB	
80H	+0.5dB	
7FH	0dB	
7EH	-0.5dB	
7DH	-1.0dB	
:	:	
02H	-62.5dB	
01H	-63dB	
00H	Mute ($-\infty$)	

Table 11. DATT Code Table

■ ALC Operation

[1] ALC Limiter Operation

When the ALC limiter is enabled, and either Lch or Rch exceed the ALC limiter detection level (LMTH bit), the IPGA value is attenuated by the amount defined in the ALC limiter ATT step (LMAT bit) automatically. Then the IPGA value is changed commonly for L/R channels.

When the ZELMN bit = "1", the timeout period is set by the LTM1-0 bits. The operation for attenuation is done continuously until the input signal level becomes the ALC limiter detection level (LMTH bit) or less. If the ALC bit does not change into "0" or the ALC pin does not change into "L" after completing the attenuation, the attenuation operation repeats until the input signal level equals or exceeds the ALC limiter detection level (LMTH bit).

When the ZELMN bit = "0", the timeout period is set by the ZTM1-0 bits. This enables the zero-crossing attenuation function so that the IPGA value is attenuated at the zero-detect points of the waveform.

When FR bit = "1", the ALC operation corresponds to the impulse noise in addition to the normal ALC operation. Then if the impulse noise is supplied at ZELMN bit = "0", the ALC operation becomes the faster period than a set of ZTM1-0 bits. In case of ZELMN bit = "1", it becomes the same period as LTM1-0 bits. When FR bit = "0", the ALC operation is the normal ALC operation.

[2] ALC Recovery Operation

The ALC recovery refers to the amount of time that the AK5366VR will allow a signal to exceed a predetermined limiting value prior to enabling the limiting function. The ALC recovery operation uses the WTM1-0 bits to define the wait period used after completing an ALC limiter operation. If the input signal does not exceed the "ALC Recovery Waiting Counter Reset Level", the ALC recovery operation starts. The IPGA value increases automatically during this operation up to the reference level (REF7-0 bits). The ALC recovery operation is done at a period set by the WTM1-0 bits. Zero crossing is detected during WTM1-0, the ALC recovery operation waits WTM1-0 period and the next recovery operation starts.

During the ALC recovery operation, when input signal level exceeds the ALC limiter detection level (LMTH bit), the ALC recovery operation changes immediately into an ALC limiter operation.

In the case of "(Recovery waiting counter reset level) ≤ Input Signal < Limiter detection level" during the ALC recovery operation, the wait timer for the ALC recovery operation is reset. Therefore, in the case of "(Recovery waiting counter reset level) > Input Signal", the wait timer for the ALC recovery operation starts.

When the impulse noise is input at FR bit = "1", the ALC recovery operation becomes faster than a normal recovery operation. When the FR bit = "0", the ALC recovery operation is done by normal period.

[3] ALC Level Diagram

(1) ALC=OFF

Figure 9 and 10 show the level diagram example at ALC=OFF. In Figure 9, Input ATT is -12dB.

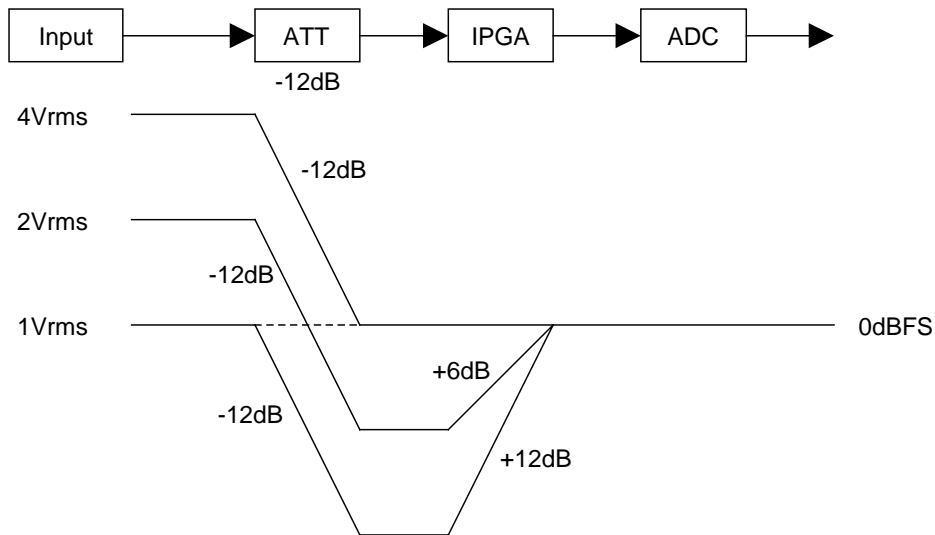

Figure 9. ALC Level diagram example (ALC=OFF)

In Figure 10, Input ATT is -6dB.

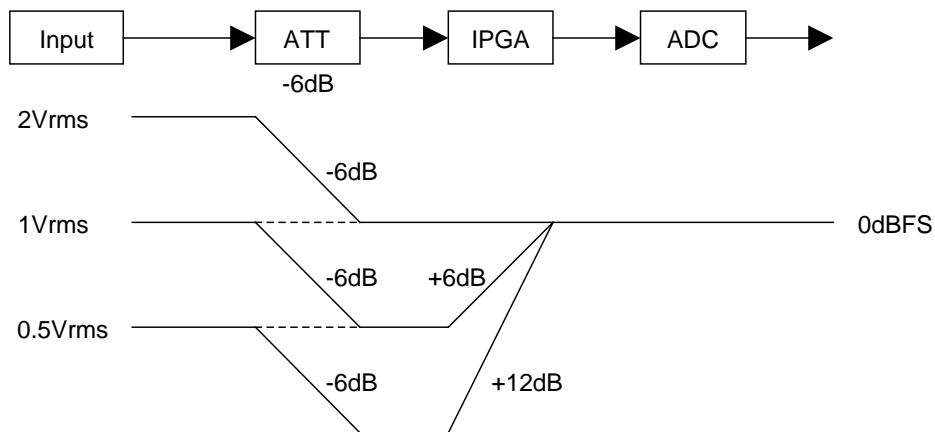

Figure 10. ALC Level diagram example (ALC=OFF)

(2) ALC=ON

Figure 11 and 12 show the level diagram example at ALC=ON. In Figure 11, Input ATT is -12dB and REF7-0 bits are "8CH".

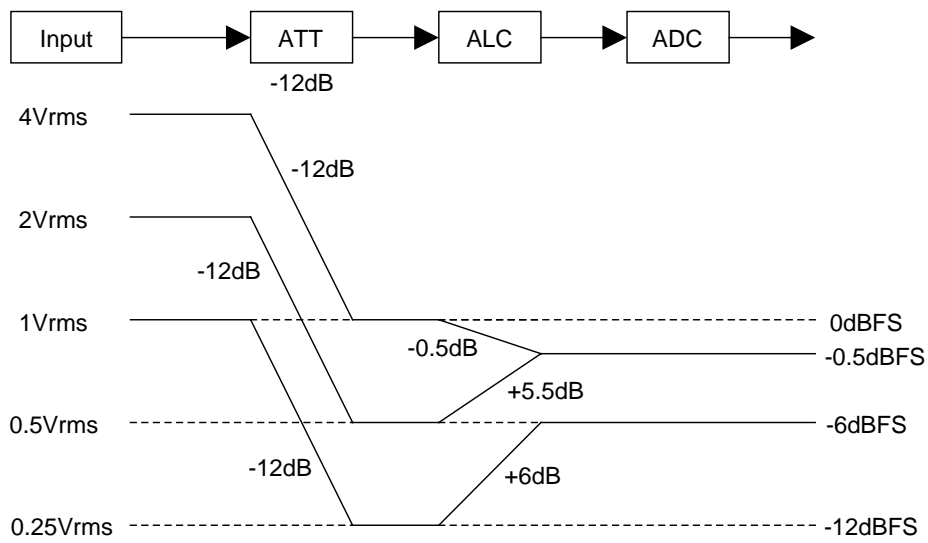

Figure 11. ALC Level diagram example (ALC=ON, LMTH bit="0")

In Figure 12, Input ATT is -6dB and REF7-0 bits are "8CH".

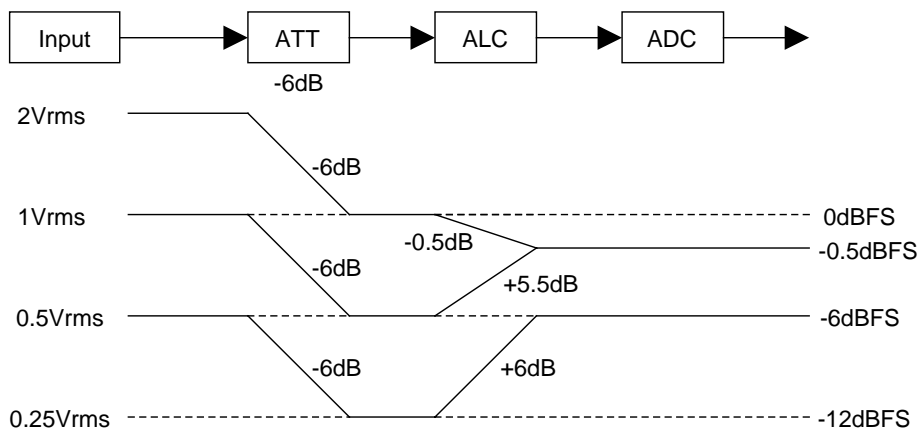

Figure 12. ALC Level diagram example (ALC=ON, LMTH="0")

[4] Example of ALC Operation

The following registers should not be changed during the ALC operation.

- **LTM1-0, LMTH, LMAT, WTM1-0, ZTM1-0, RATT, REF7-0, ZELMN bits**

- The IPGA value of Lch becomes the start value if the IPGA value is different with Lch and Rch when the ALC starts.
- Writing to the area over 80H (Table 17) of IPGL/R registers (04H, 05H) is ignored during ALC operation.

After ALC is disabled, the IPGA changes to the last written data by zero-crossing or time-out. In case of writing to the DATT area (Table 11) of DATT registers (08H, 09H), the DATT changes even if ALC is enabled.

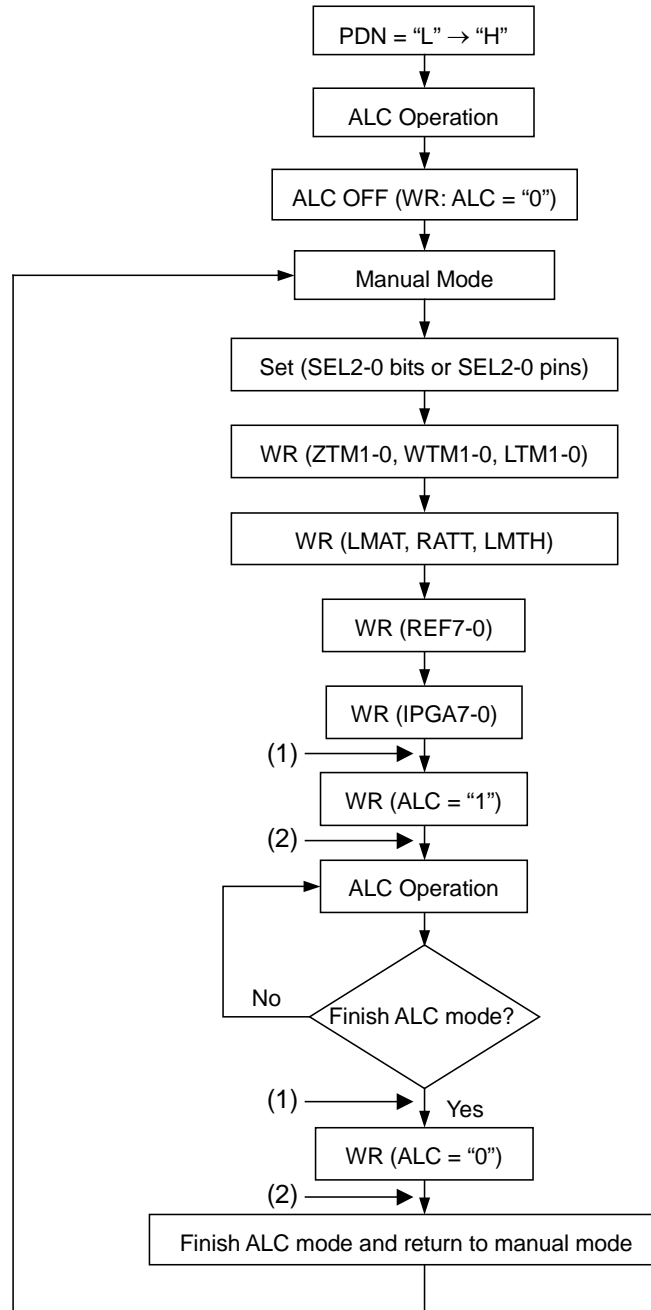

Note : WR : Write

Figure 13. Registers set-up sequence at ALC operation

(1): Enable soft mute (2): Disable soft mute

Note : After ALC operation is disabled, the IPGA changes to the last written data during or before ALC operation.

[5] IPGA value before and after ALC operation

After ALC operation is disabled, the IPGA changes to the last written data during or before ALC operation.

[Operation Example 1]

1. Set IPGA = +12dB at ALC=OFF. DATT portion is set to 0dB internally.
2. ALC=ON after soft mute is enabled.
3. Disable the soft mute.
4. During ALC operation. The IPGA changes from -9.5dB to the value set by REF7-0 bits.
5. ALC=OFF after soft mute is enabled.
6. Disable the soft mute. The IPGA return to +12dB automatically.

[Operation Example 2]

1. Set IPGA = +12dB at ALC=OFF. DATT portion is set to 0dB internally.
2. ALC=ON after soft mute is enabled.
3. Disable the soft mute.
4. During ALC operation. When the DATT portion is set to -10dB, the IPGA changes from -19.5dB to the value set by REF7-0 bits.
5. ALC=OFF after soft mute is enabled.
6. Disable the soft mute. The IPGA setting is -10dB.

■ Soft Mute Operation

Soft mute operation is performed in the digital domain of the ADC output.

Soft mute can be controlled by SMUTE bit or SMUTE pin. The SMUTE bit and SMUTE pin are ORed between pin and register. When SMUTE bit goes "1" or SMUTE pin goes "H", the ADC output data is attenuated by $-\infty$ within 1028 LRCK cycles. When the SMUTE bit returned "0" and SMUTE pin goes "L" the mute is cancelled and the output attenuation gradually changes to DATT value within 1028 LRCK cycles. If the soft mute is cancelled before mute state after starting of the operation, the attenuation is discontinued and returned to DATT value.

Soft mute function and digital volume are common.

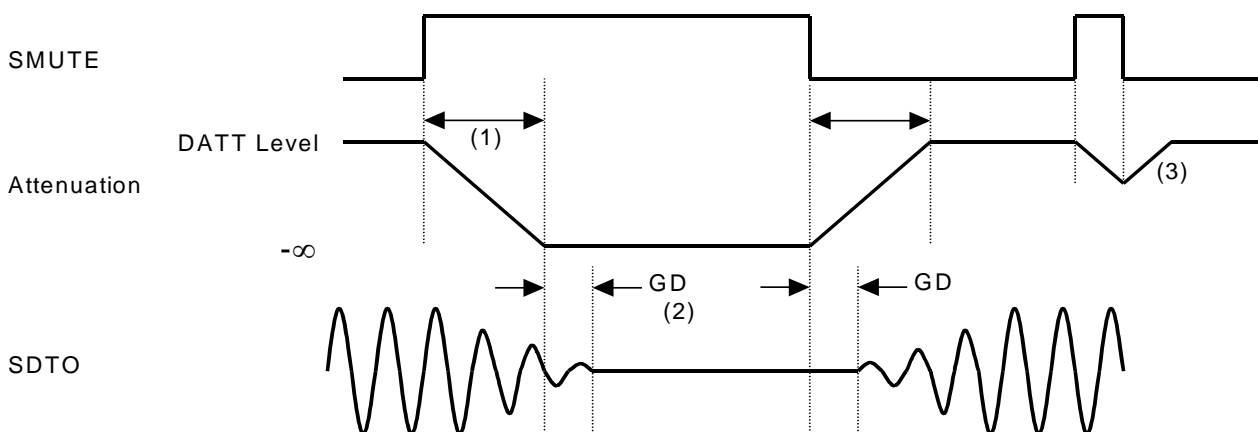

Figure 14. Soft Mute Function

- (1) The output signal is attenuated by $-\infty$ within 1028 LRCK cycles (1028/fs).
- (2) Digital output delay from the analog input is called the group delay (GD).
- (3) If the soft mute is cancelled before the mute, the attenuation is discontinued and returned to DATT value.

■ Chip Address

In case of 3-wire control mode, the chip address is fixed to C1 bit = “1” and C0 bit = “0”. Table 12 shows the relationship between chip address (C1-0 bits) and CAD1 pin in I²C-bus control mode.

CAD1 pin	C1 bit	C0 bit
L	0	Fixed to “1”
H	1	Fixed to “1”

Table 12. Chip address in I²C-bus control

Note : C1 bit should match with the input level of CAD1 pin.

■ Serial Control Interface

(1) 3-wire Serial Control Mode (I2C pin = “L”)

Internal registers may be written by using the 3-wire μP interface pins (CSN, CCLK and CDTI). The data on this interface consists of a Chip address (2bits, Fixed to “10”), Read/Write (1bit, Fixed to “1”, Write only), Register address (MSB first, 5bits) and Control data (MSB first, 8bits). Address and data is clocked in on the rising edge of CCLK and data is clocked out on the falling edge. After a low-to-high transition of CSN, data is latched for write operations. The clock speed of CCLK is 5MHz (max). The value of internal registers is initialized at PDN pin = “L”.

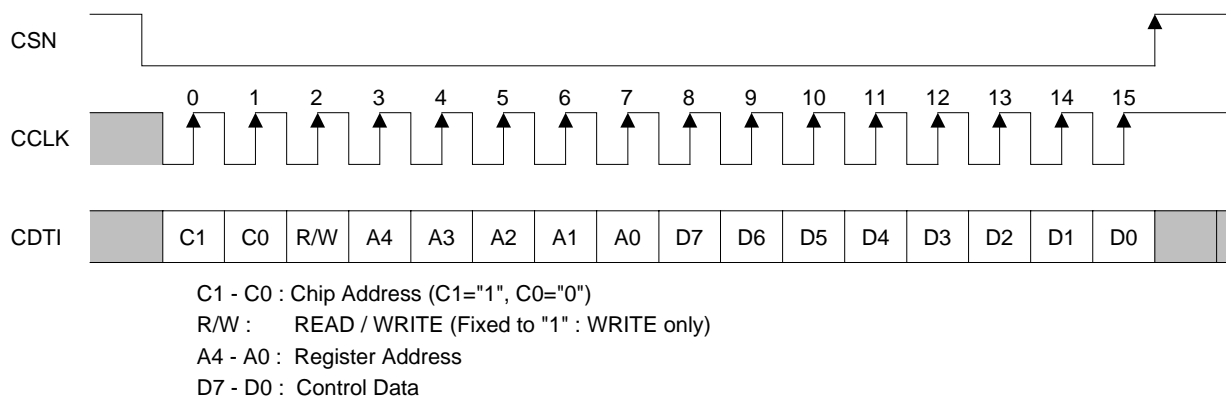

Figure 15. Serial Control I/F Timing

(2) I²C-bus Control Mode (CTRL pin = “H”)

The AK5366VR supports the standard-mode and the first-mode I²C-bus system (max: 400kHz).

(2)-1. WRITE Operations

Figure 16 shows the data transfer sequence for the I²C-bus mode. All commands are preceded by a START condition. A HIGH to LOW transition on the SDA line while SCL is HIGH indicates a START condition (Figure 22). After the START condition, a slave address is sent. This address is 7 bits long followed by an eighth bit that is a data direction bit (R/W). The most significant five bits of the slave address are fixed as “00100”. The next one bit are CAD1 (device address bits). This one bit identify the specific device on the bus. The hard-wired input pin (CAD1 pin) set these device address bits (Figure 17). If the slave address matches that of the AK5366VR, the AK5366VR generates an acknowledge and the operation is executed. The master must generate the acknowledge-related clock pulse and release the SDA line (HIGH) during the acknowledge clock pulse (Figure 23). A R/W bit value of “1” indicates that the read operation is to be executed. A “0” indicates that the write operation is to be executed.

The second byte consists of the control register address of the AK5366VR. The format is MSB first, and those most significant 3-bits are fixed to zeros (Figure 18). The data after the second byte contains control data. The format is MSB first, 8bits (Figure 19). The AK5366VR generates an acknowledge after each byte has been received. A data transfer is always terminated by a STOP condition generated by the master. A LOW to HIGH transition on the SDA line while SCL is HIGH defines a STOP condition (Figure 22).

The AK5366VR can perform more than one byte write operation per sequence. After receipt of the third byte the AK5366VR generates an acknowledge and awaits the next data. The master can transmit more than one byte instead of terminating the write cycle after the first data byte is transferred. After receiving each data packet the internal 5-bit address counter is incremented by one, and the next data is automatically taken into the next address. If the address exceeds 0DH prior to generating the stop condition, the address counter will “roll over” to 00H and the previous data will be overwritten.

The data on the SDA line must remain stable during the HIGH period of the clock. The HIGH or LOW state of the data line can only change when the clock signal on the SCL line is LOW (Figure 24) except for the START and STOP conditions.

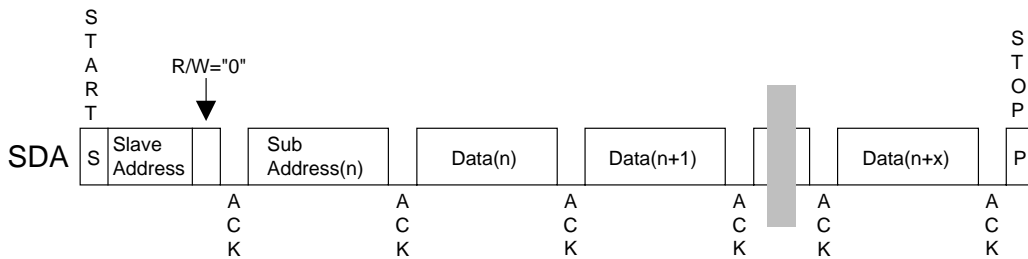
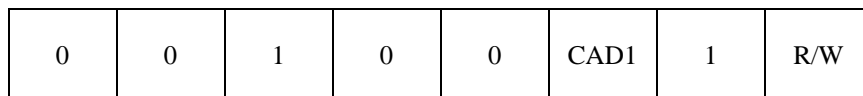

Figure 16. Data Transfer Sequence at the I²C-Bus Mode



(CAD1 should match with CAD1 pin.)

Figure 17. The First Byte

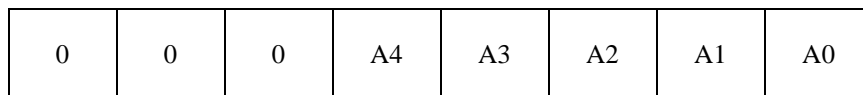

Figure 18. The Second Byte

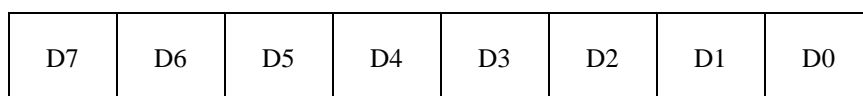

Figure 19. Byte Structure after the second byte

(2)-2. READ Operations

Set the R/W bit = "1" for the READ operation of the AK5366VR. After transmission of data, the master can read the next address's data by generating an acknowledge instead of terminating the write cycle after the receipt of the first data word. After receiving each data packet the internal 5-bit address counter is incremented by one, and the next data is automatically taken into the next address. If the address exceeds 0DH prior to generating a stop condition, the address counter will "roll over" to 00H and the previous data will be overwritten.

The AK5366VR supports two basic read operations: CURRENT ADDRESS READ and RANDOM ADDRESS READ.

(2)-2-1. CURRENT ADDRESS READ

The AK5366VR contains an internal address counter that maintains the address of the last word accessed, incremented by one. Therefore, if the last access (either a read or write) were to address n, the next CURRENT READ operation would access data from the address n+1. After receipt of the slave address with R/W bit set to "1", the AK5366VR generates an acknowledge, transmits 1-byte of data to the address set by the internal address counter and increments the internal address counter by 1. If the master does not generate an acknowledge to the data but instead generates a stop condition, the AK5366VR ceases transmission.

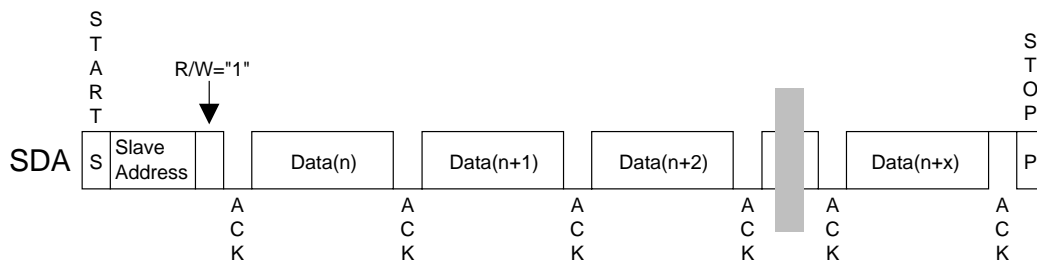

Figure 20. CURRENT ADDRESS READ

(2)-2-2. RANDOM ADDRESS READ

The random read operation allows the master to access any memory location at random. Prior to issuing the slave address with the R/W bit set to "1", the master must first perform a "dummy" write operation. The master issues a start request, a slave address (R/W bit = "0") and then the register address to read. After the register address is acknowledged, the master immediately reissues the start request and the slave address with the R/W bit set to "1". The AK5366VR then generates an acknowledge, 1 byte of data and increments the internal address counter by 1. If the master does not generate an acknowledge to the data but instead generates a stop condition, the AK5366VR ceases transmission.

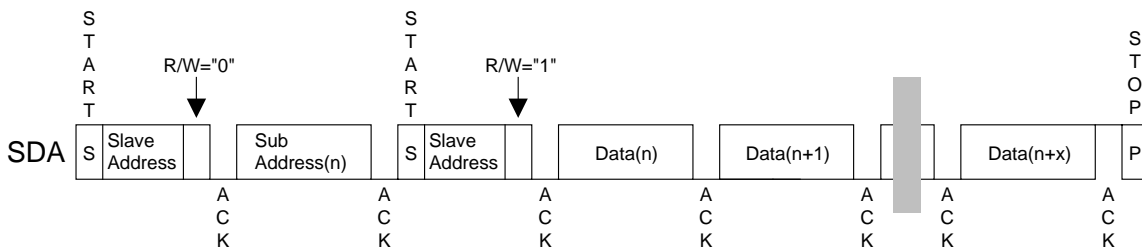

Figure 21. RANDOM ADDRESS READ

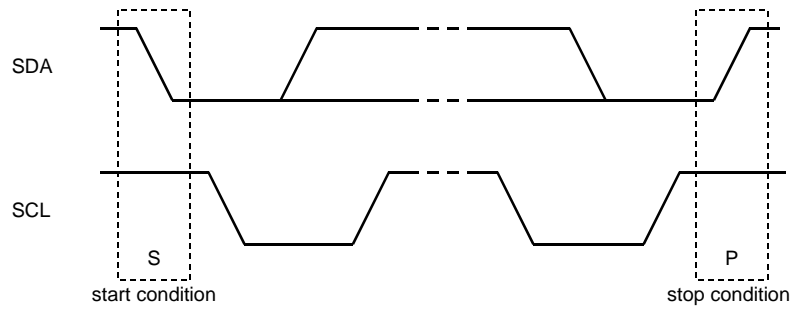

Figure 22. START and STOP Conditions

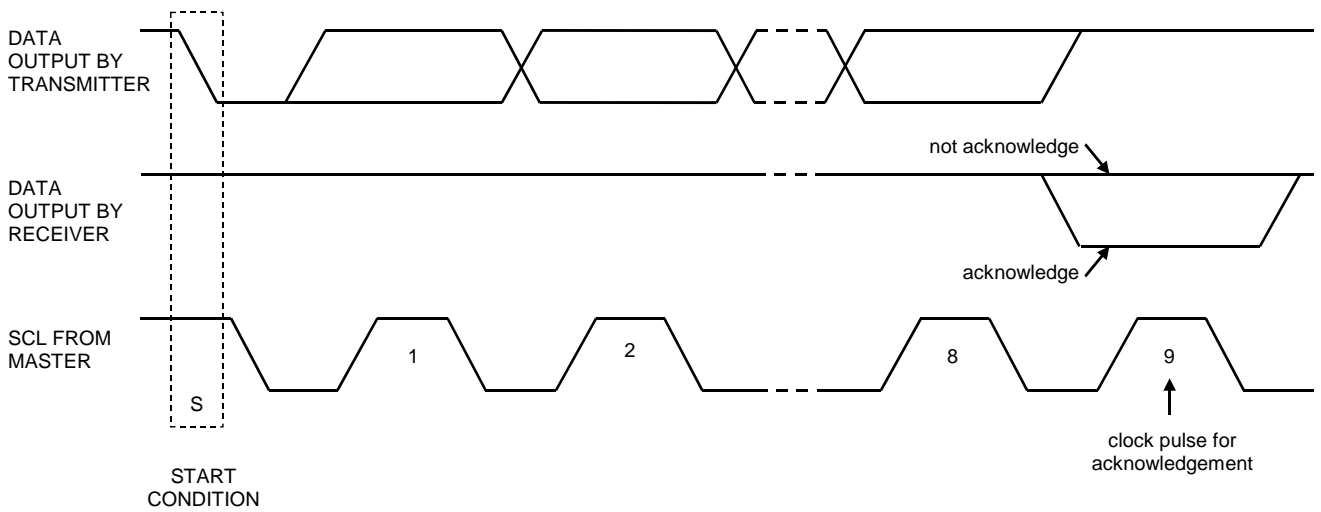

Figure 23. Acknowledge on the I²C-Bus

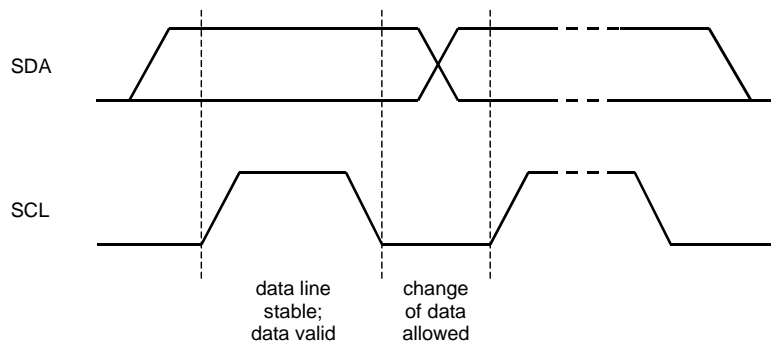

Figure 24. Bit Transfer on the I²C-Bus

■ Control by Pin and Bit

Function	Pin	bit
Input Selector	SEL2-0 Pin “LLL” : LIN1/RIN1 “LLH” : LIN2/RIN2 “LHL” : LIN3/RIN3 “LHH” : LIN4/RIN4 “HLL” : LIN5/RIN5	SEL2-0 bit “000” : LIN1/RIN1 “001” : LIN2/RIN2 “010” : LIN3/RIN3 “011” : LIN4/RIN4 “100” : LIN5/RIN5
Soft Mute	SMUTE Pin (Internal Pull-down) “L” : Normal operation “H” : Soft muted	SMUTE bit “0” : Normal operation “1” : Soft muted

Table 13. Pin and Bit control

Note : The SEL2-0 pins should be fixed to “LLL” if the AK5366VR is controlled by the SEL2-0 bits, because the setting of the

SEL2-0 pins are prior to the SEL2-0 bits setting. Soft Mute is ORed between pin and register.

■ Register Map

Addr	Register Name	D7	D6	D5	D4	D3	D2	D1	D0
00H	Power Down & Reset Control	0	0	0	0	0	MCKPD	MCKAC	PWN
01H	Input Selector Control	0	0	0	0	0	SEL2	SEL1	SEL0
02H	Clock & Format Control	0	0	0	0	DIF	CKS1	CKS0	SMUTE
03H	Timer Select	0	0	LTM1	LTM0	ZTM1	ZTM0	WTM1	WTM0
04H	Lch IPGA Control	IPGL7	IPGL6	IPGL5	IPGL4	IPGL3	IPGL2	IPGL1	IPGL0
05H	Rch IPGA Control	IPGR7	IPGR6	IPGR5	IPGR4	IPGR3	IPGR2	IPGR1	IPGR0
06H	ALC Mode Control 1	0	0	ZELMN	ALC	FR	LMTH	RATT	LMAT
07H	ALC Mode Control 2	REF7	REF6	REF5	REF4	REF3	REF2	REF1	REF0
08H	Lch DATT Control	ATTL7	ATTL6	ATTL5	ATTL7	ATTL7	ATTL7	ATTL7	ATTL0
09H	Rch DATT Control	ATTR7	ATTR6	ATTR5	ATTR4	ATTR3	ATTR2	ATTR1	ATTR0
0AH	Lch Peak Hold Low Byte	PHL7	PHL6	PHL5	PHL4	PHL3	PHL2	PHL1	PHL0
0BH	Lch Peak Hold High Byte	PHL15	PHL14	PHL13	PHL12	PHL11	PHL10	PHL9	PHL8
0CH	Rch Peak Hold Low Byte	PHR7	PHR6	PHR5	PHR4	PHR3	PHR2	PHR1	PHR0
0DH	Rch Peak Hold High Byte	PHR15	PHR14	PHR13	PHR12	PHR11	PHR10	PHR9	PHR8

PDN pin = “L” resets the registers to their default values.

Note: Unused bits must contain a “0” value.

Note: Only write to address 00H to 09H.

Note: 3-wire serial control does not support Read function. I2C control supports Read function.

■ Register Definitions

Addr	Register Name	D7	D6	D5	D4	D3	D2	D1	D0
00H	Power Down & Reset Control	0	0	0	0	0	MCKPD	MCKAC	PWN
	R/W	RD	RD	RD	RD	RD	R/W	R/W	R/W
	Default	0	0	0	0	0	0	0	1

PWN: Power down control

0 : Power down. All registers are not initialized.

1 : Normal Operation (Default)

“0” powers down all sections and then both IPGA and ADC do not operate. The contents of all register are not initialized and enabled to write to the registers.

When MCLK and LRCK are changed, it is not necessary to reset by the PDN pin or PWN bit because the AK5366VR builds in reset-free circuit. However, it can be reduced the noise by reset.

MCKAC: Master Clock input Mode Select

0 : CMOS input (Default)

1 : AC coupling input

MCKPD: MCLK Input Buffer Control

0 : Enable (Default)

1 : Disable

When MCLK input with AC coupling is stopped, MCKPD bit should be set to “1”.

Addr	Register Name	D7	D6	D5	D4	D3	D2	D1	D0
01H	Input Selector Control	0	0	0	0	0	SEL2	SEL1	SEL0
	R/W	RD	RD	RD	RD	RD	R/W	R/W	R/W
	Default	0	0	0	0	0	0	0	0

SEL2-0: Input selector (see Table 6)

Initial values are “000”.

Addr	Register Name	D7	D6	D5	D4	D3	D2	D1	D0
02H	Clock & Format Control	0	0	0	0	DIF	CKS1	CKS0	SMUTE
	R/W	RD	RD	RD	RD	R/W	R/W	R/W	R/W
	Default	0	0	0	0	0	0	0	0

SMUTE: Soft Mute control

0 : Normal Operation (Default)

1 : SDTO outputs soft-muted.

CKS1-0: Master clock frequency select (see Table 2)

Initial values are “00”.

DIF: Audio interface format (see Table 4)

Initial values are “0” (24bit, MSB first).

Addr	Register Name	D7	D6	D5	D4	D3	D2	D1	D0
03H	Timer Select	0	0	LTM1	LTM0	ZTM1	ZTM0	WTM1	WTM0
	R/W	RD	RD	R/W	R/W	R/W	R/W	R/W	R/W
	Default	0	0	1	0	1	0	1	1

WTM1-0: ALC Recovery waiting time (see Table 14)

A period of recovery operation when any limiter operation does not occur during the ALC operation.

WTM1	WTM0	ALC recovery operation waiting period	@fs=48kHz
0	0	288/fs	6ms
0	1	1152/fs	24ms
1	0	2304/fs	48ms
1	1	4608/fs	96ms

Default

Table 14. ALC recovery waiting time

ZTM1-0: Zero crossing timeout (see Table 15)

When the IPGA of each L/R channels perform zero crossing or timeout independently, the IPGA value is changed by the μ P WRITE operation, ALC recovery operation or ALC limiter operation (ZELMN bit = "0").

ZTM1	ZTM0	Zero crossing timeout period	@fs=48kHz
0	0	288/fs	6ms
0	1	1152/fs	24ms
1	0	2304/fs	48ms
1	1	4608/fs	96ms

Default

Table 15. Zero crossing timeout

LTM1-0: ALC Limiter period (see Table 16)

When ZELMN bit = "1", the IPGA value is changed immediately. When the IPGA value is changed continuously, the change is done by the period set by the LTM1-0 bits.

LTM1	LTM0	ALC limiter operation period	@fs=48kHz
0	0	3/fs	63 μ s
0	1	6/fs	125 μ s
1	0	12/fs	250 μ s
1	1	24/fs	500 μ s

Default

Table 16. ALC limiter period

Addr	Register Name	D7	D6	D5	D4	D3	D2	D1	D0
04H	Lch IPGA Control	IPGL7	IPGL6	IPGL5	IPGL4	IPGL3	IPGL2	IPGL1	IPGL0
05H	Rch IPGA Control	IPGR7	IPGR6	IPGR5	IPGR4	IPGR3	IPGR2	IPGR1	IPGR0
	R/W	R/W	R/W	R/W	R/W	R/W	R/W	R/W	R/W
	Default	1	0	0	0	0	0	0	0

IPGL/R7-0: Input PGA & Digital volume control (see Table 17)
Initial values are "80H".

The data must not be written under 80H.

Writing to the area over 7FH (Table 17) of IPGL/R registers (04H, 05H) is ignored during ALC operation. After ALC is disabled, the IPGA changes to the last written data by zero-crossing or time-out. In case of writing to the DATT area (Table 11) of DATT registers (08H, 09H), the DATT changes even if ALC is enabled.

Data (hex)	Gain (dB)	Step width (dB)	
A4H	+18	0.5	IPGA Analog volume with 0.5dB step
:	:	0.5	
9EH	+15	0.5	
:	:	0.5	
98H	+12	0.5	
97H	+11.5	0.5	
96H	+11	0.5	
:	:	0.5	
82H	+1.0	0.5	
81H	+0.5	0.5	
80H	0	-	

Table 17. IPGA Code Table

Addr	Register Name	D7	D6	D5	D4	D3	D2	D1	D0
06H	ALC Mode Control 1	0	0	ZELMN	ALC	FR	LMTH	RATT	LMAT
	R/W	RD	RD	R/W	R/W	R/W	R/W	R/W	R/W
	Default	0	0	1	0	1	0	0	0

LMAT: ALC Limiter ATT step (see Table 18)

During the ALC limiter operation, when either Lch or Rch exceeds the ALC limiter detection level set by LMTH bit, the number of steps attenuated from the current IPGA value is set. For example, when the current IPGA value is 94H and the LMAT bit = "1", the IPGA transition to 92H when the ALC limiter operation starts, resulting in the input signal level being attenuated by 1dB (=0.5dB x 2).

LMAT	ATT Step
0	1
1	2

Default

Table 18. ALC limiter ATT step

RATT: ALC Recovery gain step (see Table 19)

During the ALC recovery operation, the number of steps changed from the current IPGA value is set. For example, when the current IPGA value is 82H and RATT bit = "1" is set, the IPGA changes to 84H by the ALC recovery operation and the output signal level is gained up by 1dB (=0.5dB x 2). When the IPGA value exceeds the reference level (REF7-0 bits), the IPGA value does not increase.

RATT	Gain Step
0	1
1	2

Default

Table 19. ALC recovery gain step

LMTH: ALC Limiter detection level / Recovery waiting counter reset level (see Table 20)

The ALC limiter detection level and the ALC recovery counter reset level may be offset by about ± 2 dB.

LMTH	ALC Limiter Detection Level	ALC Recovery Waiting Counter Reset Level
0	ALC Output ≥ -0.5 dBFS	-0.5 dBFS > ALC Output ≥ -2.5 dBFS
1	ALC Output ≥ -2.0 dBFS	-2.0 dBFS > ALC Output ≥ -4.0 dBFS

Default

Table 20. ALC Limiter detection level / Recovery waiting counter reset level

FR: ALC fast recovery

0 : Disable

1 : Enable (Default)

When the impulse noise is input, the ALC recovery operation becomes faster than a normal recovery operation.

ALC: ALC enable flag

0 : ALC Disable (Default)

1 : ALC Enable

ZELMN: Zero crossing enable flag at ALC limiter operation

0 : Enable

1 : Disable (Default)

When the ZELMN bit = "0", the IPGA of each L/R channel perform a zero crossing or timeout independently. The zero crossing timeout is the same as the ALC recovery operation. When the ZELMN bit = "1", the IPGA value is changed immediately. The ALC Limiter period can be set up by a ZTM 1-0 bits when ZELMN bit = "0", it can be set up by a LTM1-0 bits when ZELMN bit = "1"

Addr	Register Name	D7	D6	D5	D4	D3	D2	D1	D0
07H	ALC Mode Control 2	REF7	REF6	REF5	REF4	REF3	REF2	REF1	REF0
R/W		R/W	R/W	R/W	R/W	R/W	R/W	R/W	R/W
Default		1	0	0	0	1	1	1	0

REF7-0: Reference value at ALC recovery operation (see Table 21)

During the ALC recovery operation, if the IPGA value exceeds the setting reference value by gain operation, then the IPGA does not become larger than the reference value.

The REF7-0 bits should not be set up except for Table 21.

DATA (hex)	Gain (dB)
A4H	+18.0
:	:
90H	+8.0
8FH	+7.5
8EH	+7.0
8DH	+6.5
:	:
89H	+4.5
:	:
81H	+0.5
80H	0

Default

Table 21. Reference value at ALC recovery operation

Addr	Register Name	D7	D6	D5	D4	D3	D2	D1	D0
08H	Lch DATT Control	ATTL7	ATTL6	ATTL5	ATTL4	ATTL3	ATTL2	ATTL1	ATTL0
09H	Rch DATT Control	ATTR7	ATTR6	ATTR5	ATTR4	ATTR3	ATTR2	ATTR1	ATTR0
R/W		R/W	R/W	R/W	R/W	R/W	R/W	R/W	R/W
Default		0	1	1	1	1	1	1	1

ATTL/R7-0: Digital output volume control (see Table 11)

Initial value is “7FH”.

The data must not be written over 90H.

When PDN pin = “L”, ATTL/R7-0 bits are initialized “7FH”.

When PWN bit = “0”, the DATT holds the last setting value.

Addr	Register Name	D7	D6	D5	D4	D3	D2	D1	D0
0AH	Lch Peak Hold Low Byte	PHL7	PHL6	PHL5	PHL4	PHL3	PHL2	PHL1	PHL0
0BH	Lch Peak Hold High Byte	PHL15	PHL14	PHL13	PHL12	PHL11	PHL10	PHL9	PHL8
0CH	Rch Peak Hold Low Byte	PHR7	PHR6	PHR5	PHR4	PHR3	PHR2	PHR1	PHR0
0DH	Rch Peak Hold High Byte	PHR15	PHR14	PHR13	PHR12	PHR11	PHR10	PHR9	PHR8
R/W		RD							
Default		0	0	0	0	0	0	0	0

PHL15-0: Lch Peak Hold Low/High Byte

PHR15-0: Rch Peak Hold Low/High Byte

The AK5366VR includes the peak hold circuit. The peak is held L/R audio data independently. These registers are reset by reading 8bit of MSB, reading 8bit of both MSB and LSB should be continuity controlled by reading in order of 8bit of MSB from LSB. After reading 8bit of LSB the last, 8bit of MSB is lost by reading 8bit of LSB the last. The output value is the absolute value. Full scale is “FFFFH”.

These registers are reset by PDN pin = “L” or PWN bit = “0”.

SYSTEM DESIGN

Figure 25 shows the system connection diagram. An evaluation board is available which demonstrates application circuits, the optimum layout, power supply arrangements and measurement results.

- Master Mode, 3-wire control (I2C pin = "L")

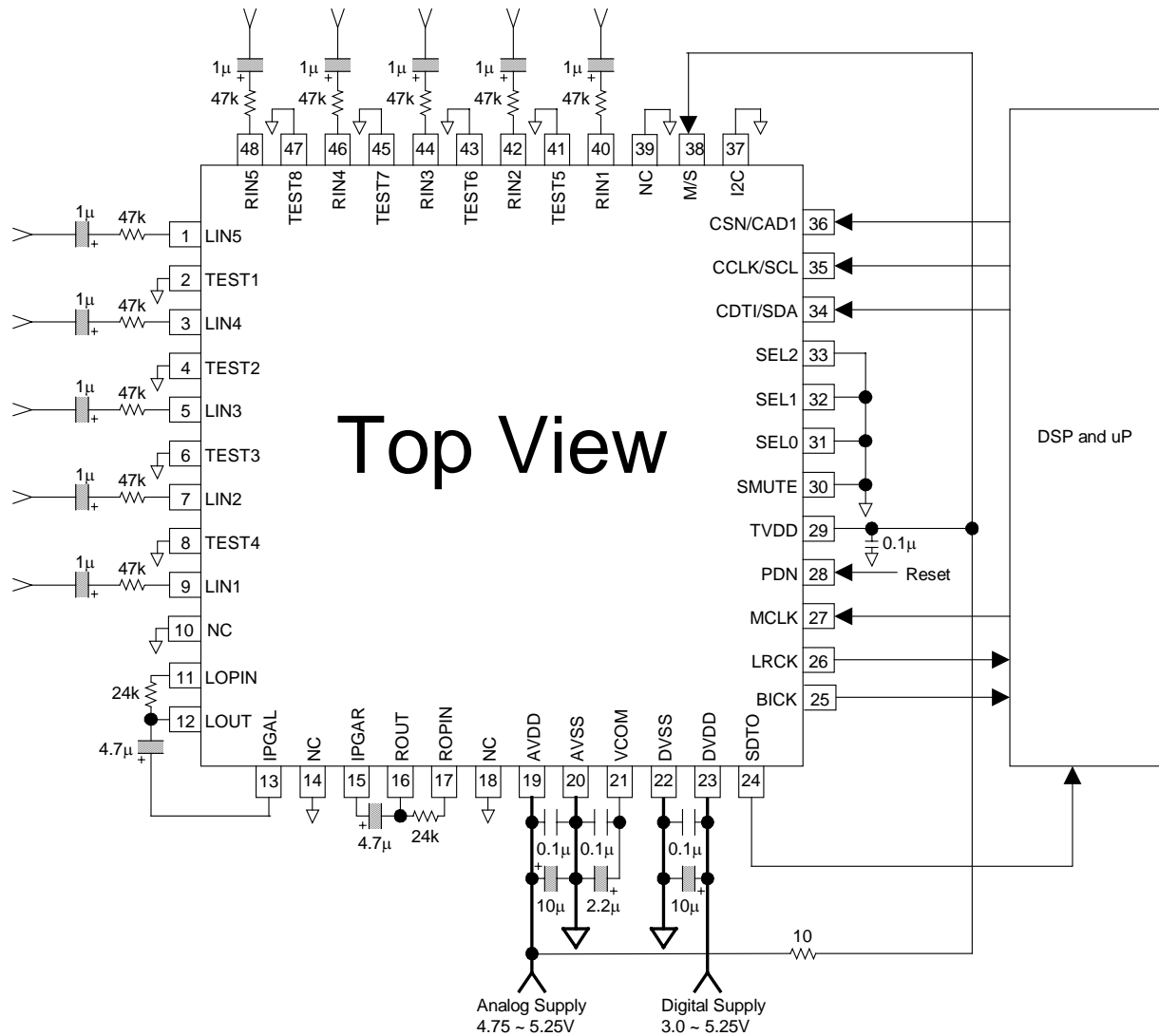

Note:

- AVSS and DVSS of the AK5366VR should be distributed separately from the ground of external digital devices (MPU, DSP etc.).
- When LOUT/ROUT drives a capacitive load, resistors should be added in series between LOUT/ROUT and capacitive load.
- All digital input pins should not be left floating.
- M/S pin should be connected to AVDD or AVSS.

Figure 25. Typical Connection Diagram

1. Grounding and Power Supply Decoupling

The AK5366VR requires careful attention to power supply and grounding arrangements. AVDD, DVDD and TVDD are usually supplied from the analog supply in the system. Alternatively if AVDD, DVDD and TVDD are supplied separately, the power up sequence is not critical. **AVSS and DVSS of the AK5366VR must be connected to analog ground plane.** System analog ground and digital ground should be connected together near to where the supplies are brought onto the printed circuit board. Decoupling capacitors should be as near to the AK5366VR as possible, with the small value ceramic capacitor being the closest.

2. Voltage Reference Inputs

The differential voltage between AVDD and AVSS sets the analog input range. VCOM is a signal ground of this chip. An electrolytic capacitor 2.2 μ F parallel with a 0.1 μ F ceramic capacitor attached to VCOM pin eliminates the effects of high frequency noise. No load current may be drawn from the VCOM pin. All signals, especially clocks, should be kept away from the VREF and VCOM pins in order to avoid unwanted coupling into the AK5366VR.

3. Analog Inputs

An analog input of AK5366VR is single-ended input to Pre-Amp through the external resistor. For input signal range, adjust feedback resistor so that Pre-Amp output may become the input range (typ. 0.2 x AVDD Vrms) of IPGA (IPGAL, IPGAR pin). Between the Pre-Amp output (LOUT, ROUT pin) and the IPGA input (IPGAL, IPGAR pin) is AC coupled with capacitor. When the impedance of IPGAL/R pins is "R" and the capacitor of between the Pre-Amp output and the IPGA input is "C", the cut-off frequency is $f_c = 1/(2\pi RC)$.

The ADC output data format 2's complement. The internal HPF removes the DC offset.

The AK5366VR samples the analog inputs at 64fs. The digital filter rejects noise above the stop band except for multiples of 64fs. The AK5366VR includes an anti-aliasing filter (RC filter) to attenuate a noise around 64fs.

4. Attention to the PCB Wiring

LIN1-5 and RIN1-5 pins are the summing nodes of the Pre-Amp. Attention should be given to avoid coupling with other signals on those nodes. This can be accomplished by making the wire length of the input resistors as short as possible. The same theory also applies to the LOPIN/ROPIN pins and feedback resistors; keep the wire length to a minimum. Unused input pins among LIN1-5 and RIN1-5 pins should be left open.

When external devices are connected to LOUT and ROUT pin, the input impedance of an external device which the LOUT and ROUT pins can drive is min 6.3k Ω .

PACKAGE

48pin LQFP(Unit:mm)

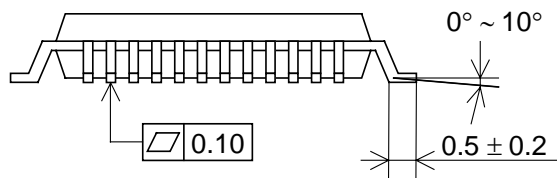
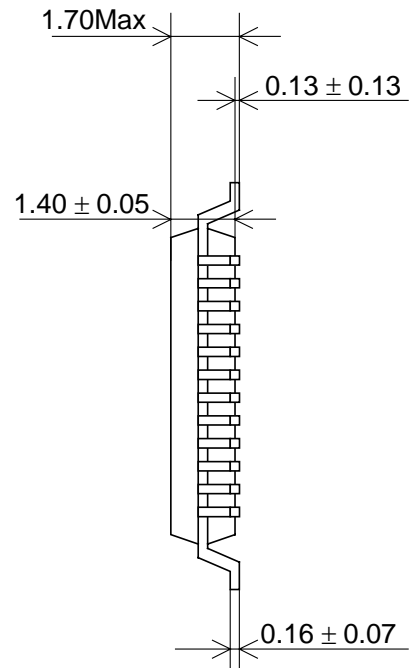
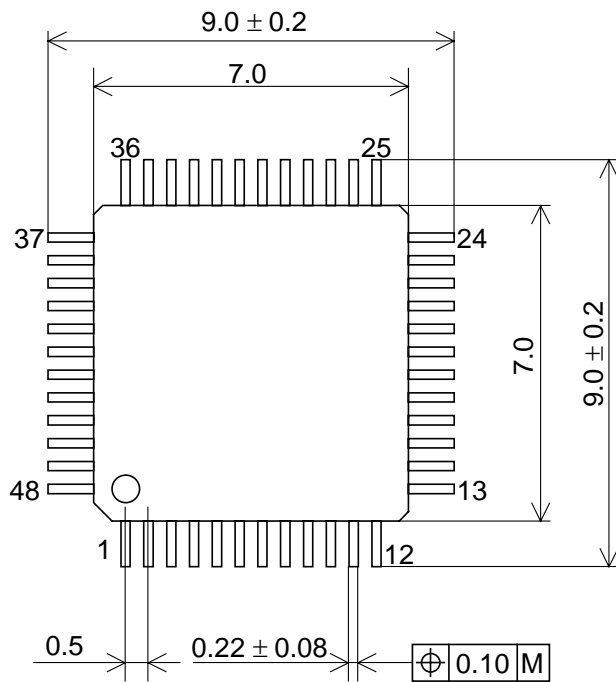

■ Material & Lead finish

- Package molding compound: Epoxy
- Lead frame material: Cu
- Lead frame surface treatment: Solder (Pb free) plate

MARKING

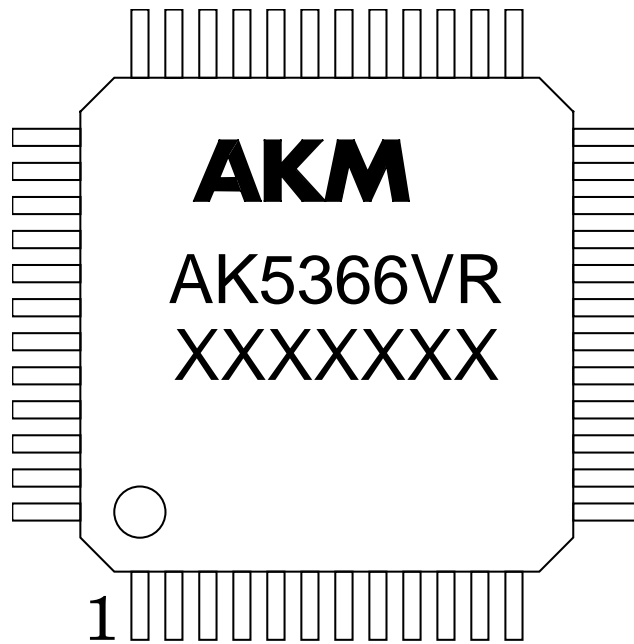

XXXXXXX : Date Code Identifier (7 digits)

Date (YY/MM/DD)	Revision	Reason	Page	Contents
06/07/20	00	First edition		

IMPORTANT NOTICE

- These products and their specifications are subject to change without notice. Before considering any use or application, consult the Asahi Kasei Microsystems Co., Ltd. (AKM) sales office or authorized distributor concerning their current status.
- AKM assumes no liability for infringement of any patent, intellectual property, or other right in the application or use of any information contained herein.
- Any export of these products, or devices or systems containing them, may require an export license or other official approval under the law and regulations of the country of export pertaining to customs and tariffs, currency exchange, or strategic materials.
- AKM products are neither intended nor authorized for use as critical components in any safety, life support, or other hazard related device or system, and AKM assumes no responsibility relating to any such use, except with the express written consent of the Representative Director of AKM. As used here:
 - a. A hazard related device or system is one designed or intended for life support or maintenance of safety or for applications in medicine, aerospace, nuclear energy, or other fields, in which its failure to function or perform may reasonably be expected to result in loss of life or in significant injury or damage to person or property.
 - b. A critical component is one whose failure to function or perform may reasonably be expected to result, whether directly or indirectly, in the loss of the safety or effectiveness of the device or system containing it, and which must therefore meet very high standards of performance and reliability.
- It is the responsibility of the buyer or distributor of an AKM product who distributes, disposes of, or otherwise places the product with a third party to notify that party in advance of the above content and conditions, and the buyer or distributor agrees to assume any and all responsibility and liability for and hold AKM harmless from any and all claims arising from the use of said product in the absence of such notification.