



#### GENERAL DESCRIPTION

The AK4114 is a digital audio transceiver supporting 192kHz, 24bits. The channel status decoder supports both consumer and professional modes. The AK4114 can automatically detect a Non-PCM bit stream. When combined with the multi channel codec (AK4527B or AK4529), the two chips provide a system solution for AC-3 applications. The dedicated pins or a serial  $\mu$ P I/F can control the mode setting. The small package, 48pin LQFP saves the system space.

\*AC-3 is a trademark of Dolby Laboratories.

#### FEATURES

- AES3, IEC60958, S/PDIF, EIAJ CP1201 Compatible
- Low jitter Analog PLL
- PLL Lock Range : 32kHz to 192kHz
- Clock Source: PLL or X'tal
- 8-channel Receiver input
- 2-channel Transmission output (Through output or DIT)
- Auxiliary digital input
- De-emphasis for 32kHz, 44.1kHz, 48kHz and 96kHz
- Detection Functions
  - Non-PCM Bit Stream Detection
  - DTS-CD Bit Stream Detection
  - Sampling Frequency Detection  
(32kHz, 44.1kHz, 48kHz, 88.2kHz, 96kHz, 176.4kHz, 192kHz)
  - Unlock & Parity Error Detection
  - Validity Flag Detection
- Up to 24bit Audio Data Format
- Audio I/F: Master or Slave Mode
- 40-bit Channel Status Buffer
- Burst Preamble bit Pc and Pd Buffer for Non-PCM bit stream
- Q-subcode Buffer for CD bit stream
- Serial  $\mu$ P I/F
- Two Master Clock Outputs: 64fs/128fs/256fs/512fs
- Operating Voltage: 2.7 to 3.6V with 5V tolerance
- Small Package: 48pin LQFP
- Ta: -10 to 70°C

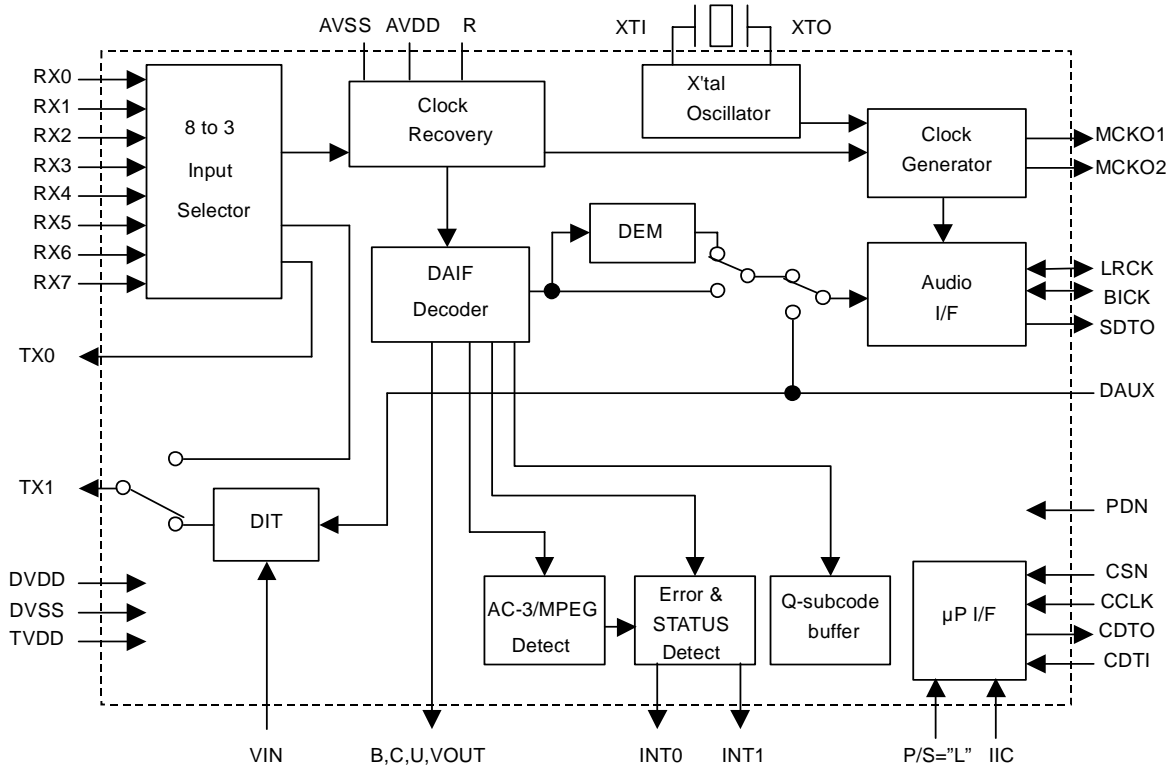

Serial Control Mode

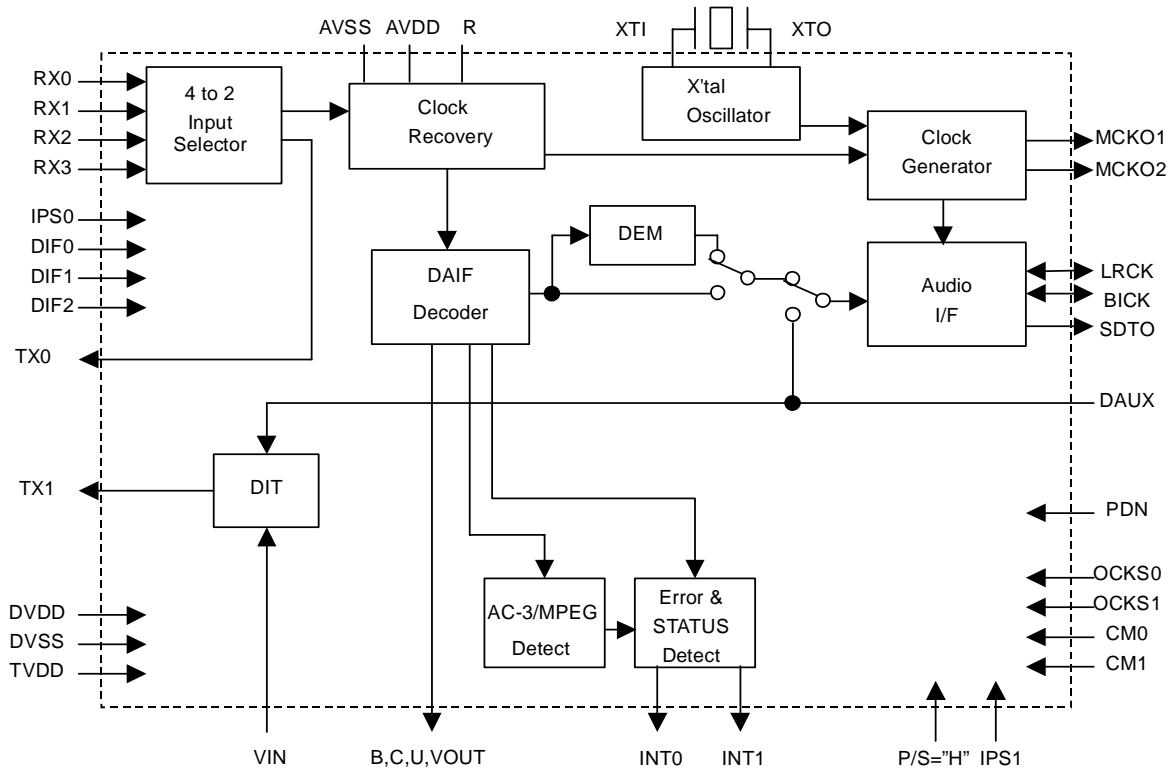

Parallel Control Mode

■ Ordering Guide

AK4114VQ      -10 ~ +70 °C      48pin LQFP (0.5mm pitch)

■ Pin Layout

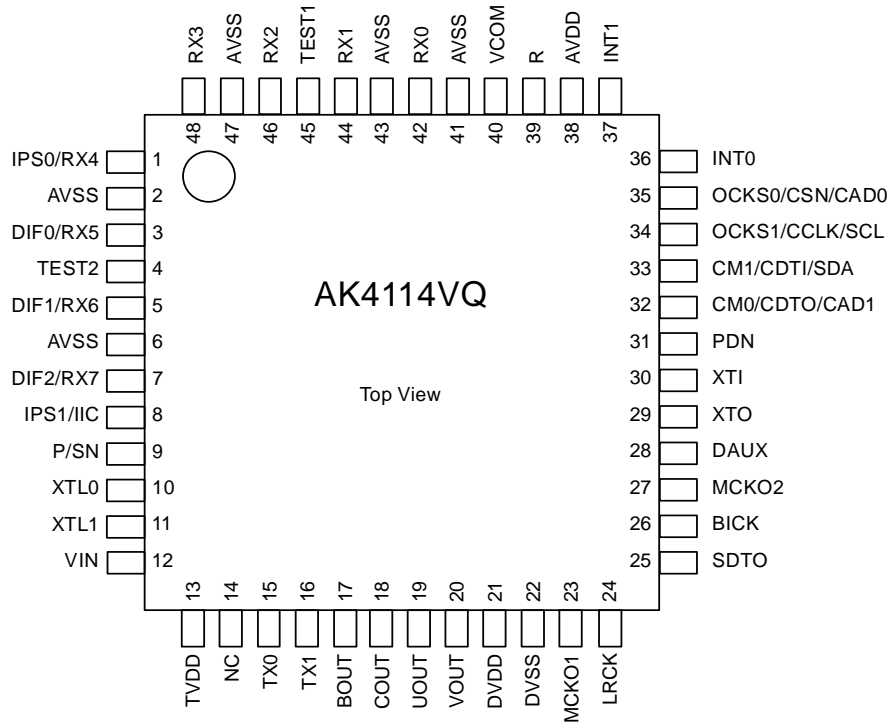

PIN/FUNCTION			
No.	Pin Name	I/O	Function
1	IPS0	I	Input Channel Select 0 Pin in Parallel Mode
	RX4	I	Receiver Channel 4 Pin in Serial Mode (Internal biased pin)
2	NC(AVSS)	I	No Connect No internal bonding. This pin should be connected to AVSS.
3	DIF0	I	Audio Data Interface Format 0 Pin in Parallel Mode
	RX5	I	Receiver Channel 5 Pin in Serial Mode (Internal biased pin)
4	TEST2	I	TEST 2 pin This pin should be connect to AVSS.
5	DIF1	I	Audio Data Interface Format 1 Pin in Parallel Mode
	RX6	I	Receiver Channel 6 Pin in Serial Mode (Internal biased pin)
6	NC(AVSS)	I	No Connect No internal bonding. This pin should be connected to AVSS.
7	DIF2	I	Audio Data Interface Format 2 Pin in Parallel Mode
	RX7	I	Receiver Channel 7 Pin in Serial Mode (Internal biased pin)
8	IPS1	I	Input Channel Select 1 Pin in Parallel Mode
	IIC	I	IIC Select Pin in Serial Mode. “L”: 4-wire Serial, “H”: IIC
9	P/SN	I	Parallel/Serial Select Pin “L”: Serial Mode, “H”: Parallel Mode
10	XTL0	I	X'tal Frequency Select 0 Pin
11	XTL1	I	X'tal Frequency Select 1 Pin
12	VIN	I	V-bit Input Pin for Transmitter Output
13	TVDD	I	Input Buffer Power Supply Pin, 3.3V or 5V
14	NC	I	No Connect No internal bonding. This pin should be open or connected to DVSS.
15	TX0	O	Transmit Channel (Through Data) Output 0 Pin
16	TX1	O	When TX bit = “0”, Transmit Channel (Through Data) Output 1 Pin. When TX bit = “1”, Transmit Channel (DAUX Data) Output Pin (Default).
17	BOUT	O	Block-Start Output Pin for Receiver Input “H” during first 40 frames.
18	COUT	O	C-bit Output Pin for Receiver Input
19	UOUT	O	U-bit Output Pin for Receiver Input
20	VOUT	O	V-bit Output Pin for Receiver Input
21	DVDD	I	Digital Power Supply Pin, 3.3V
22	DVSS	I	Digital Ground Pin
23	MCKO1	O	Master Clock Output 1 Pin
24	LRCK	I/O	Channel Clock Pin
25	SDTO	O	Audio Serial Data Output Pin
26	BICK	I/O	Audio Serial Data Clock Pin
27	MCKO2	O	Master Clock Output 2 Pin
28	DAUX	I	Auxiliary Audio Data Input Pin
29	XTO	O	X'tal Output Pin
30	XTI	I	X'tal Input Pin

## PIN/FUNCTION (Continued)

No.	Pin Name	I/O	Function
31	PDN	I	Power-Down Mode Pin When "L", the AK4114 is powered-down and reset.
32	CM0	I	Master Clock Operation Mode 0 Pin in Parallel Mode
	CDTO	O	Control Data Output Pin in Serial Mode, IIC= "L".
	CAD1	I	Chip Address 1 Pin in Serial Mode, IIC= "H".
33	CM1	I	Master Clock Operation Mode 1 Pin in Parallel Mode
	CDTI	I	Control Data Input Pin in Serial Mode, IIC= "L".
	SDA	I/O	Control Data Pin in Serial Mode, IIC= "H".
34	OCKS1	I	Output Clock Select 1 Pin in Parallel Mode
	CCLK	I	Control Data Clock Pin in Serial Mode, IIC= "L"
	SCL	I	Control Data Clock Pin in Serial Mode, IIC= "H"
35	OCKS0	I	Output Clock Select 0 Pin in Parallel Mode
	CSN	I	Chip Select Pin in Serial Mode, IIC="L".
	CAD0	I	Chip Address 0 Pin in Serial Mode, IIC= "H".
36	INT0	O	Interrupt 0 Pin
37	INT1	O	Interrupt 1 Pin
38	AVDD	I	Analog Power Supply Pin, 3.3V
39	R	-	External Resistor Pin 18k $\Omega$ +/-1% resistor should be connected to AVSS externally.
40	VCOM	-	Common Voltage Output Pin 0.47 $\mu$ F capacitor should be connected to AVSS externally.
41	AVSS	I	Analog Ground Pin
42	RX0	I	Receiver Channel 0 Pin (Internal biased pin) This channel is default in serial mode.
43	NC(AVSS)	I	No Connect No internal bonding. This pin should be connected to AVSS.
44	RX1	I	Receiver Channel 1 Pin (Internal biased pin)
45	TEST1	I	TEST 1 pin. This pin should be connected to AVSS.
46	RX2	I	Receiver Channel 2 Pin (Internal biased pin)
47	NC(AVSS)	I	No Connect No internal bonding. This pin should be connected to AVSS.
48	RX3	I	Receiver Channel 3 Pin (Internal biased pin)

Note 1. All input pins except internal biased pins should not be left floating.

**ABSOLUTE MAXIMUM RATINGS**

(AVSS, DVSS=0V; Note 2)

Parameter	Symbol	min	max	Units	
Power Supplies:	Analog	AVDD	-0.3	4.6	V
	Digital	DVDD	-0.3	4.6	V
	Input Buffer	TVDD	-0.3	6.0	V
	AVSS-DVSS  (Note 3)	ΔGND		0.3	V
Input Current (Any pins except supplies)	IIN	-	±10	mA	
Input Voltage (Except XTI pin)	VIN	-0.3	TVDD+0.3	V	
Input Voltage (XTI pin)	VINX	-0.3	DVDD+0.3	V	
Ambient Temperature (Power applied)	Ta	-10	70	°C	
Storage Temperature	Tstg	-65	150	°C	

Note 2. All voltages with respect to ground.

Note 3. AVSS and DVSS must be connected to the same ground.

WARNING: Operation at or beyond these limits may result in permanent damage to the device.

Normal operation is not guaranteed at these extremes.

**RECOMMENDED OPERATING CONDITIONS**

(AVSS, DVSS=0V; Note 2)

Parameter	Symbol	min	typ	max	Units	
Power Supplies:	Analog	AVDD	2.7	3.3	3.6	V
	Digital	DVDD	2.7	3.3	AVDD	V
	Input Buffer	TVDD	DVDD	3.3	5.5	V

Note 2. All voltages with respect to ground.

**S/PDIF RECEIVER CHARACTERISTICS**

(Ta=25°C; AVDD, DVDD=2.7~3.6V;TVDD=2.7~5.5V)

Parameter	Symbol	min	typ	max	Units
Input Resistance	Zin		10		kΩ
Input Voltage	VTH	200			mVpp
Input Hysteresis	VHY		50		mV
Input Sample Frequency	fs	32	-	192	kHz

**DC CHARACTERISTICS**

(Ta=25°C; AVDD, DVDD=2.7~3.6V;TVDD=2.7~5.5V; unless otherwise specified)

Parameter	Symbol	min	typ	max	Units
Power Supply Current	Normal operation: PDN = "H" (Note 4)		28	56	mA
	Power down: PDN = "L" (Note 5)		10	100	μA
High-Level Input Voltage	VIH	70%DVDD	-	TVDD	V
Low-Level Input Voltage	VIL	DVSS-0.3	-	30%DVDD	V
High-Level Output Voltage (Iout=-400μA)	VOH	DVDD-0.4	-	-	V
Low-Level Output Voltage	(Except SDA pin: Iout=400μA)	VOL	-	0.4	V
	( SDA pin: Iout= 3mA)	VOL	-	0.4	V
Input Leakage Current	Iin	-	-	± 10	μA

Note 4. AVDD, DVDD=3.3V, TVDD=5.0V, C<sub>L</sub>=20pF, fs=192kHz, X'tal=24.576MHz, Clock Operation Mode 2,

OCKS1=1, OCKS0=1. AVDD=11mA (typ), DVDD=17mA (typ), TVDD=10μA (typ).

DVDD=28mA (typ) when the circuit of Figure 22 is attached to both TX0 and TX1 pins.

Note 5. RX inputs are open and all digital input pins are held DVDD or DVSS.

SWITCHING CHARACTERISTICS						
(Ta=25°C; DVDD, AVDD2.7~3.6V, TVDD=2.7~5.5V; CL=20pF)						
Parameter		Symbol	min	typ	max	Units
<b>Master Clock Timing</b>						
Crystal Resonator	Frequency	fXTAL	11.2896		24.576	MHz
External Clock	Frequency	fECLK	11.2896		24.576	MHz
	Duty	dECLK	40	50	60	%
MCKO1 Output	Frequency	fMCK1	4.096		24.576	MHz
	Duty	dMCK1	40	50	60	%
MCKO2 Output	Frequency	fMCK2	2.048		24.576	MHz
	Duty	dMCK2	40	50	60	%
PLL Clock Recover Frequency (RX0-7)		fpll	32	-	192	kHz
LRCK Frequency		fs	32		192	kHz
Duty Cycle		dLCK	45		55	%
<b>Audio Interface Timing</b>						
<b>Slave Mode</b>						
BICK Period		tBCK	80			ns
BICK Pulse Width Low		tBCKL	30			ns
Pulse Width High		tBCKH	30			ns
LRCK Edge to BICK “↑”	(Note 6)	tLRB	20			ns
BICK “↑” to LRCK Edge	(Note 6)	tBLR	20			ns
LRCK to SDTO (MSB)		tLRM			30	ns
BICK “↓” to SDTO		tBSD			30	ns
DAUX Hold Time		tDXH	20			ns
DAUX Setup Time		tDXS	20			ns
<b>Master Mode</b>						
BICK Frequency		fBCK		64fs		Hz
BICK Duty		dBCK		50		%
BICK “↓” to LRCK		tMBLR	-20		20	ns
BICK “↓” to SDTO		tBSD			10	ns
DAUX Hold Time		tDXH	20			ns
DAUX Setup Time		tDXS	20			ns
<b>Control Interface Timing (4-wire serial mode)</b>						
CCLK Period		tCCK	200			ns
CCLK Pulse Width Low		tCCKL	80			ns
Pulse Width High		tCCKH	80			ns
CDTI Setup Time		tCDS	50			ns
CDTI Hold Time		tCDH	50			ns
CSN “H” Time		tCSW	150			ns
CSN “↓” to CCLK “↑”		tCSS	50			ns
CCLK “↑” to CSN “↑”		tCSH	50			ns
CDTO Delay		tDCD			45	ns
CSN “↑” to CDTO Hi-Z		tCCZ			70	ns

Note 6. BICK rising edge must not occur at the same time as LRCK edge.

**SWITCHING CHARACTERISTICS (Continued)**

(Ta=25°C; DVDD, AVDD2.7~3.6V, TVDD=2.7~5.5V; CL=20pF)

Parameter	Symbol	min	typ	max	Units
<b>Control Interface Timing (I<sup>2</sup>C Bus mode):</b>					
SCL Clock Frequency	fSCL	-		100	kHz
Bus Free Time Between Transmissions	tBUF	4.7		-	μs
Start Condition Hold Time (prior to first clock pulse)	tHD:STA	4.0		-	μs
Clock Low Time	tLOW	4.7		-	μs
Clock High Time	tHIGH	4.0		-	μs
Setup Time for Repeated Start Condition	tSU:STA	4.7		-	μs
SDA Hold Time from SCL Falling (Note 7)	tHD:DAT	0		-	μs
SDA Setup Time from SCL Rising	tSU:DAT	250		-	ns
Rise Time of Both SDA and SCL Lines	tR	-		1000	ns
Fall Time of Both SDA and SCL Lines	tF	-		300	ns
Setup Time for Stop Condition	tSU:STO	4.0		-	μs
Capacitive load on bus	Cb	-		400	pF
<b>Reset Timing</b>					
PDN Pulse Width	tPW	150			ns

Note 7. Data must be held for sufficient time to bridge the 300 ns transition time of SCL.

Note 8. I<sup>2</sup>C is a registered trademark of Philips Semiconductors.

Purchase of Asahi Kasei Microsystems Co., Ltd I<sup>2</sup>C components conveys a license under the Philips I<sup>2</sup>C patent to use the components in the I<sup>2</sup>C system, provided the system conform to the I<sup>2</sup>C specifications defined by Philips.



■ Timing Diagram

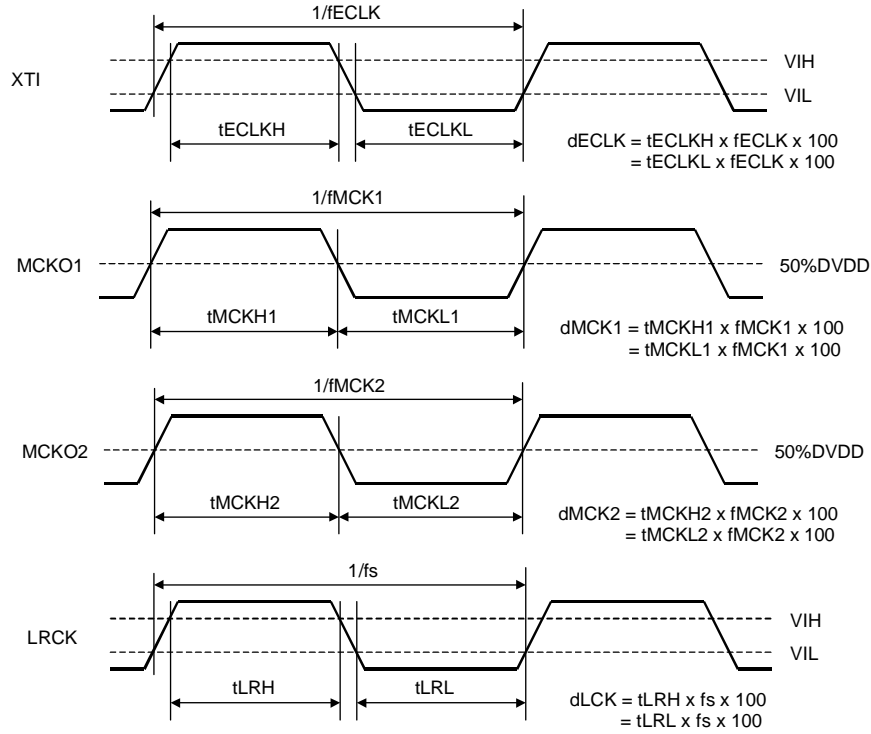

Figure 1. Clock Timing

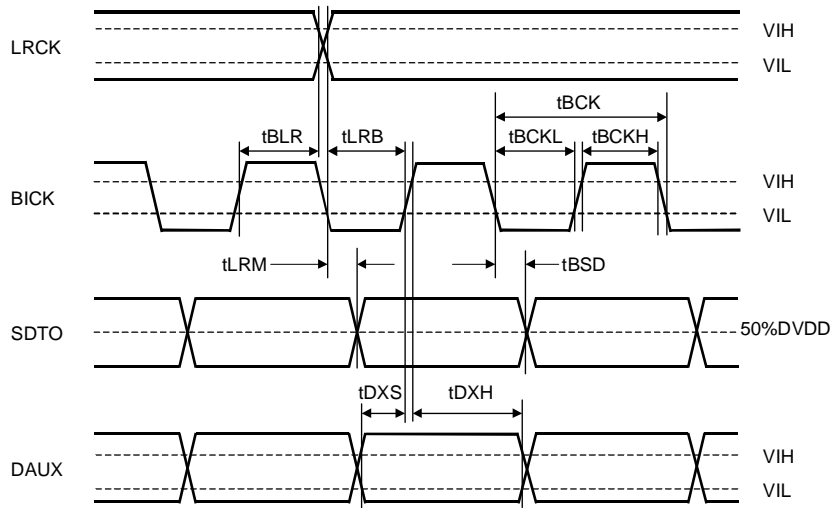

Figure 2. Serial Interface Timing (Slave Mode)

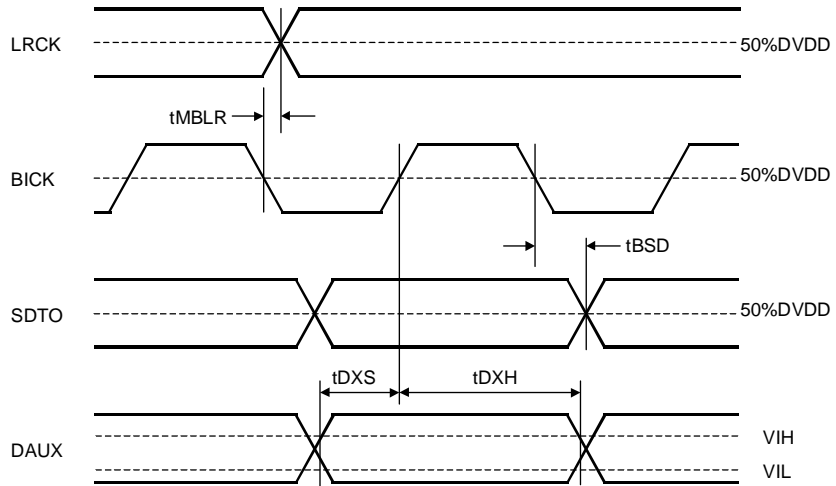

Figure 3. Serial Interface Timing (Master Mode)

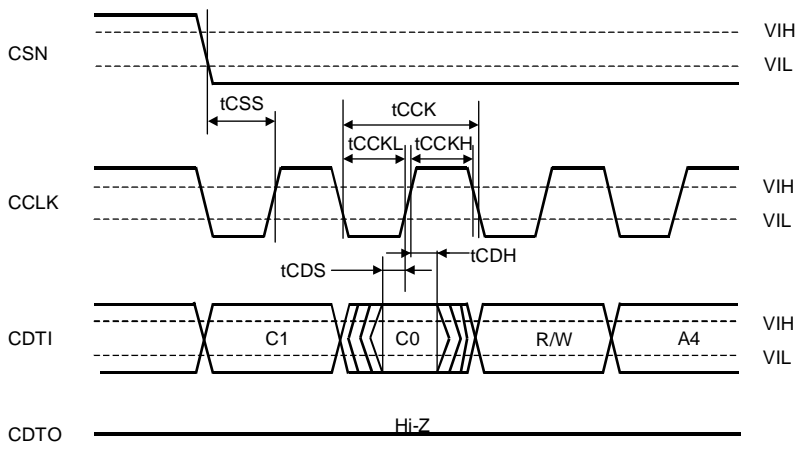

Figure 4. WRITE/READ Command Input Timing in 4-wire serial mode

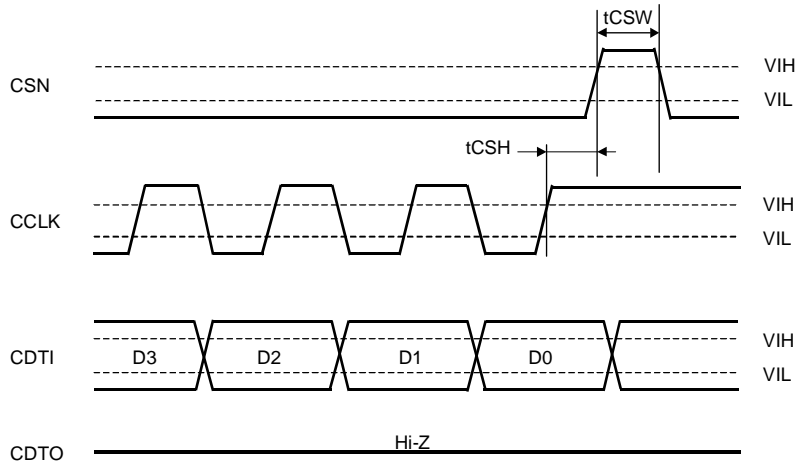

Figure 5. WRITE Data Input Timing in 4-wire serial mode

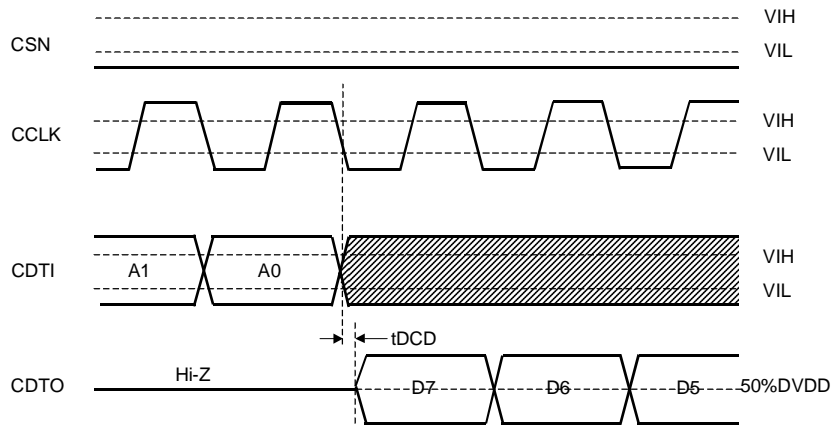

Figure 6. READ Data Output Timing 1 in 4-wire serial mode

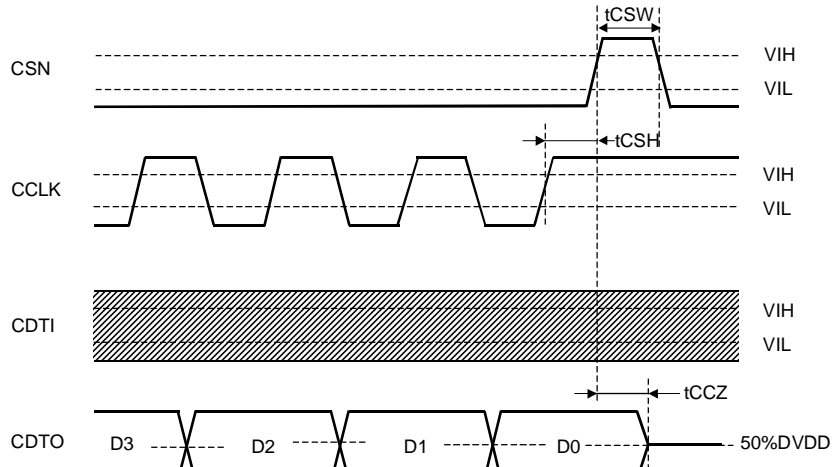

Figure 7. READ Data Input Timing 2 in 4-wire serial mode

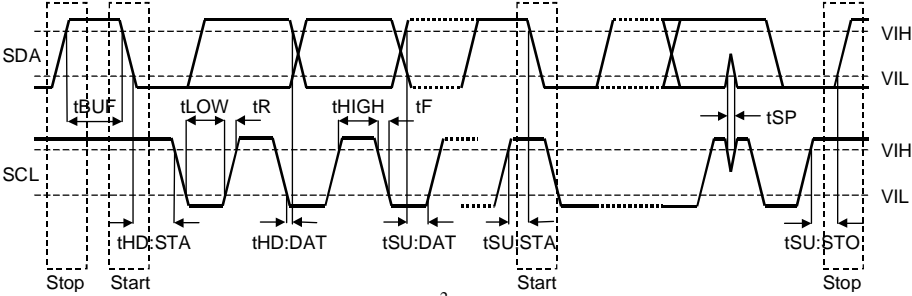

Figure 8. I<sup>2</sup>C Bus mode Timing

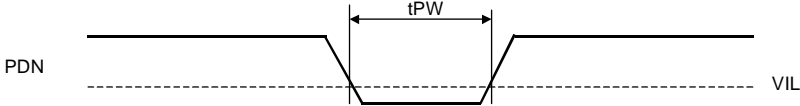

Figure 9. Power Down & Reset Timing

## OPERATION OVERVIEW

### ■ Non-PCM (AC-3, MPEG, etc.) and DTS-CD Bitstream Detection

The AK4114 has a Non-PCM steam auto-detection function. When the 32bit mode Non-PCM preamble based on Dolby “AC-3 Data Stream in IEC60958 Interface” is detected, the AUTO bit goes “1”. The 96bit sync code consists of 0x0000, 0x0000, 0x0000, 0x0000, 0xF872 and 0x4E1F. Detection of this pattern will set the AUTO “1”. Once the AUTO is set “1”, it will remain “1” until 4096 frames pass through the chip without additional sync pattern being detected. When those preambles are detected, the burst preambles Pc and Pd that follow those sync codes are stored to registers. The AK4114 also has the DTS-CD bitstream auto-detection function. When AK4114 detects DTS-CD bitstreams, DTSCD bit goes to “1”. When the next sync code does not come within 4096 flames, DTSCD bit goes to “0” until when AK4114 detects the stream again.

### ■ 192kHz Clock Recovery

On chip low jitter PLL has a wide lock range with 32kHz to 192kHz and the lock time is less than 20ms. The AK4114 has the sampling frequency detect function. By either the clock comparison against X’tal oscillator or using the channel status, AK4114 detects the sampling frequency (32kHz, 44.1kHz, 48kHz, 88.2kHz, 96kHz, 176.4kHz and 192kHz). The PLL loses lock when the received sync interval is incorrect.

### ■ Master Clock

The AK4114 has two clock outputs, MCKO1 and MCKO2. These clocks are derived from either the recovered clock or from the X’tal oscillator. The frequencies of the master clock outputs (MCKO1 and MCKO2) are set by OCKS0 and OCKS1 as shown in Table 1. The 512fs clock will not output when 96kHz and 192kHz. The 256fs clock will not output when 192kHz.

No.	OCKS1	OCKS0	MCKO1	MCKO2	X’tal	fs (max)	Default
0	0	0	256fs	256fs	256fs	96 kHz	
1	0	1	256fs	128fs	256fs	96 kHz	
2	1	0	512fs	256fs	512fs	48 kHz	
3	1	1	128fs	64fs	128fs	192 kHz	

Table 1. Master Clock Frequency Select (Stereo mode)

### ■ Clock Operation Mode

The CM0/CM1 pins (or bits) select the clock source and the data source of SDTO. In Mode 2, the clock source is switched from PLL to X’tal when PLL goes unlock state. In Mode3, the clock source is fixed to X’tal, but PLL is also operating and the recovered data such as C bits can be monitored. For Mode2 and 3, it is recommended that the frequency of X’tal is different from the recovered frequency from PLL.

Mode	CM1	CM0	UNLOCK	PLL	X’tal	Clock source	SDTO	Default
0	0	0	-	ON	ON(Note)	PLL	RX	
1	0	1	-	OFF	ON	X’tal	DAUX	
2	1	0	0	ON	ON	PLL	RX	
			1	ON	ON	X’tal	DAUX	
3	1	1	-	ON	ON	X’tal	DAUX	

ON: Oscillation (Power-up), OFF: STOP (Power-down)

Note : When the X’tal is not used as clock comparison for fs detection (i.e. XTL1,0= “1,1”), the X’tal is off.

Table 2. Clock Operation Mode select

■ Clock Source

The following circuits are available to feed the clock to XTI pin of AK4114.

1) X'tal

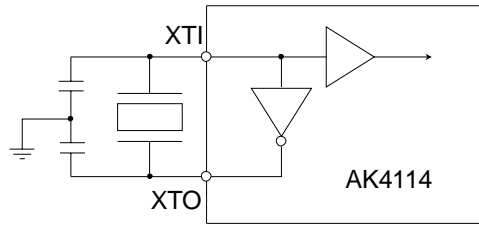

Figure 10. X'tal mode

Note: External capacitance depends on the crystal oscillator (Typ. 10-40pF)

2) External clock

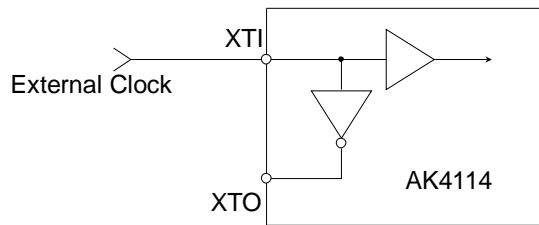

Figure 11. External clock mode

Note: Input clock must not exceed DVDD.

3) Fixed to the Clock Operation Mode 0

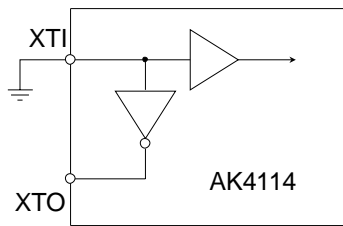

Figure 12. off mode

■ Sampling Frequency and Pre-emphasis Detection

The AK4114 has two methods for detecting the sampling frequency as follows.

1. Clock comparison between recovered clock and X'tal oscillator
2. Sampling frequency information on channel status

Those could be selected by XTL1, 0 bits. And the detected frequency is reported on FS3-0 bits.

XTL1	XTL0	X'tal Frequency	Default
0	0	11.2896MHz	
0	1	12.288MHz	
1	0	24.576MHz	
1	1	(Use channel status)	

Table 3. Reference X'tal frequency

Register output				fs	Except XTL1,0= "1,1"	XTL1,0= "1,1"		
					Clock comparison (Note 1)	Consumer mode (Note 2)	Professional mode	
FS3	FS2	FS1	FS0		Byte3 Bit3,2,1,0	Byte0 Bit7,6	Byte4 Bit6,5,4,3	
0	0	0	0	44.1kHz	44.1kHz	0 0 0 0	0 1	0 0 0 0
0	0	0	1	Reserved	Reserved	0 0 0 1	(Others)	
0	0	1	0	48kHz	48kHz	0 0 1 0	1 0	0 0 0 0
0	0	1	1	32kHz	32kHz	0 0 1 1	1 1	0 0 0 0
1	0	0	0	88.2kHz	88.2kHz	( 1 0 0 0 )	0 0	1 0 1 0
1	0	1	0	96kHz	96kHz	( 1 0 1 0 )	0 0	0 0 1 0
1	1	0	0	176.4kHz	176.4kHz	( 1 1 0 0 )	0 0	1 0 1 1
1	1	1	0	192kHz	192kHz	( 1 1 1 0 )	0 0	0 0 1 1

Note1: At least ±3% range is identified as the value in the Table 4. In case of intermediate frequency of those two, FS3-0 bits indicate nearer value. When the frequency is much bigger than 192kHz or much smaller than 32kHz, FS3-0 bits may indicate "0001".

Note2: When consumer mode, Byte3 Bit3-0 are copied to FS3-0.

Table 4. fs Information

The pre-emphasis information is detected and reported on PEM bit. These information are extracted from channel 1 at default. It can be switched to channel 2 by CS12 bit in control register.

PEM	Pre-emphasis	Byte 0 Bits 3-5
0	OFF	≠ 0X100
1	ON	0X100

Table 5. PEM in Consumer Mode

PEM	Pre-emphasis	Byte 0 Bits 2-4
0	OFF	≠ 110
1	ON	110

Table 6. PEM in Professional Mode

■ De-emphasis Filter Control

The AK4114 includes the digital de-emphasis filter (tc=50/15µs) by IIR filter corresponding to four sampling frequencies (32kHz, 44.1kHz, 48kHz and 96kHz). When DEAU bit="1", the de-emphasis filter is enabled automatically by sampling frequency and pre-emphasis information in the channel status. The AK4114 goes this mode at default. Therefore, in Parallel Mode, the AK4114 is always placed in this mode and the status bits in channel 1 control the de-emphasis filter. In Serial Mode, DEM0/1 and DFS bits can control the de-emphasis filter when DEAU is "0". The internal de-emphasis filter is bypassed and the recovered data is output without any change if either pre-emphasis or de-emphasis Mode is OFF.

PEM	FS3	FS2	FS1	FS0	Mode
1	0	0	0	0	44.1kHz
1	0	0	1	0	48kHz
1	0	0	1	1	32kHz
1	1	0	1	0	96kHz
1	(Others)				OFF
0	x	x	x	x	OFF

Table 7. De-emphasis Auto Control at DEAU = "1" (Default)

PEM	DFS	DEM1	DEM0	Mode
1	0	0	0	44.1kHz
1	0	0	1	OFF
1	0	1	0	48kHz
1	0	1	1	32kHz
1	1	0	0	OFF
1	1	0	1	OFF
1	1	1	0	96kHz
1	1	1	1	OFF
0	x	x	x	OFF

Default

Table 8. De-emphasis Manual Control at DEAU = "0"

■ System Reset and Power-Down

The AK4114 has a power-down mode for all circuits by PDN pin can be partially power-down by PWN bit. The RSTN bit initializes the register and resets the internal timing. In Parallel Mode, only the control by PDN pin is enabled. The AK4114 should be reset once by bringing PDN pin = "L" upon power-up.

PDN Pin:

All analog and digital circuit are placed in the power-down and reset mode by bringing PDN= "L". All the registers are initialized, and clocks are stopped. Reading/Writing to the register are disabled.

RSTN Bit (Address 00H; D0):

All the registers except PWN and RSTN are initialized by bringing RSTN bit = "0". The internal timings are also initialized. Writing to the register is not available except PWN and RSTN. Reading to the register is disabled.

PWN Bit (Address 00H; D1):

The clock recovery part is initialized by bringing PWN bit = "0". In this case, clocks are stopped. The registers are not initialized and the mode settings are kept. Writing and Reading to the registers are enabled.



■ Biphase Input and Through Output

Eight receiver inputs (RX0-7) are available in Serial Control Mode. Each input includes amplifier corresponding to unbalance mode and can accept the signal of 200mV or more. IPS2-0 selects the receiver channel. When BCU bit = "1", the Block start signal, C bit and U bit can output from each pins.

IPS2	IPS1	IPS0	INPUT Data
0	0	0	RX0
0	0	1	RX1
0	1	0	RX2
0	1	1	RX3
1	0	0	RX4
1	0	1	RX5
1	1	0	RX6
1	1	1	RX7

Default

Table 9. Recovery Data Select

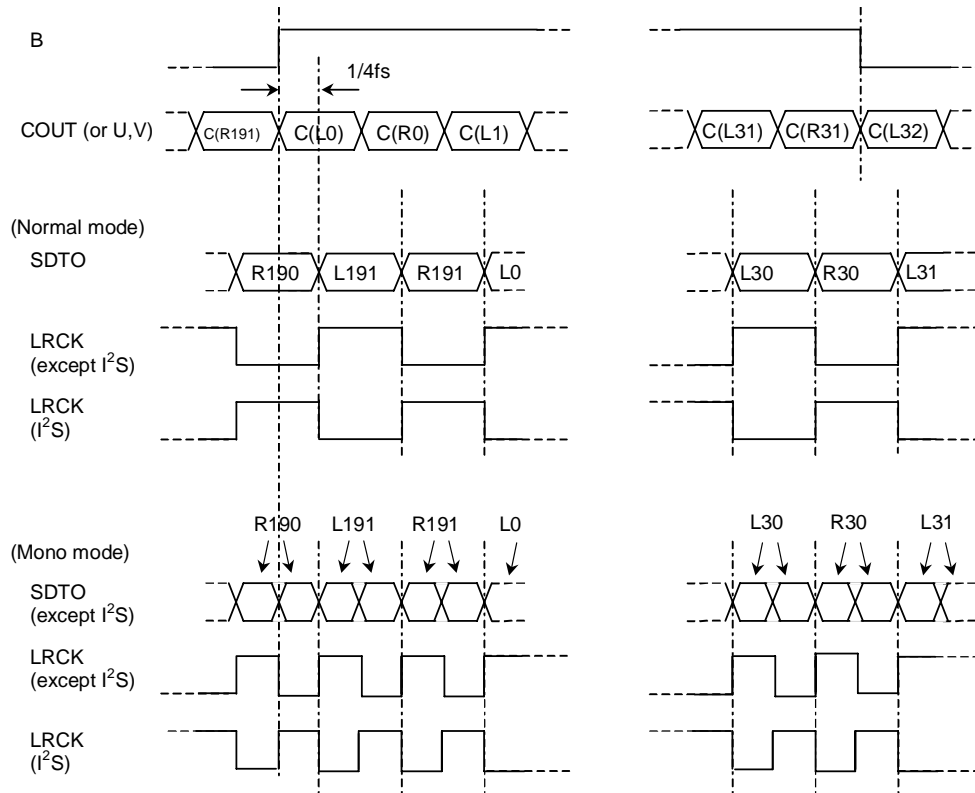

Figure 13. B, C, U, V output/input timings

■ Biphase Output

The AK4114 can output either the through output(from DIR) or transmitter output(DIT; the data from DAUX is transformed to IEC60958 format.) from TX1/0 pins. Those could be selected by DIT bit. The source of the through output from TX0 could be selected among RX0-8 by OPS00,01 and 02 bits, for TX1, by OPS10,11 and 12 bits respectively. When output DAUX data, V bit could be controlled by VIN pin and first 5 bytes of C bit could be controlled by CT39-CT0 bits in control registers. When bit0= "0"(consumer mode), bit20-23(Audio channel) could not be controlled directly but be controlled by CT20 bit. When the CT20 bit is "1", AK4114 outputs "1000" as C20-23 for left channel and output "0100" at C20-23 for right channel automatically. When CT20 bit is "0", AK4114 outputs "0000" set as "1000" for sub frame 1, and "0100" for sub frame 2. U bits are fixed to "0".as C20-23 for both channel. U bit could be controlled by UDIT bit as follows; When UDIT bit is "0", U bit is always "L". When UDIT bit is "1", the recovered U bits are used for DIT( DIR-DIT loop mode of U bit). This mode is only available when PLL is locked and the master mode.

OPS02	OPS01	OPS00	Output Data
0	0	0	RX0
0	0	1	RX1
0	1	0	RX2
0	1	1	RX3
1	0	0	RX4
1	0	1	RX5
1	1	0	RX6
1	1	1	RX7

Default

Table 10. Output Data Select for TX0

DIT	OPS12	OPS11	OPS10	Output Data
0	0	0	0	RX0
0	0	0	1	RX1
0	0	1	0	RX2
0	0	1	1	RX3
0	1	0	0	RX4
0	1	0	1	RX5
0	1	1	0	RX6
0	1	1	1	RX7
1	x	x	x	DAUX

Default

Table 11. Output Data Select for TX1

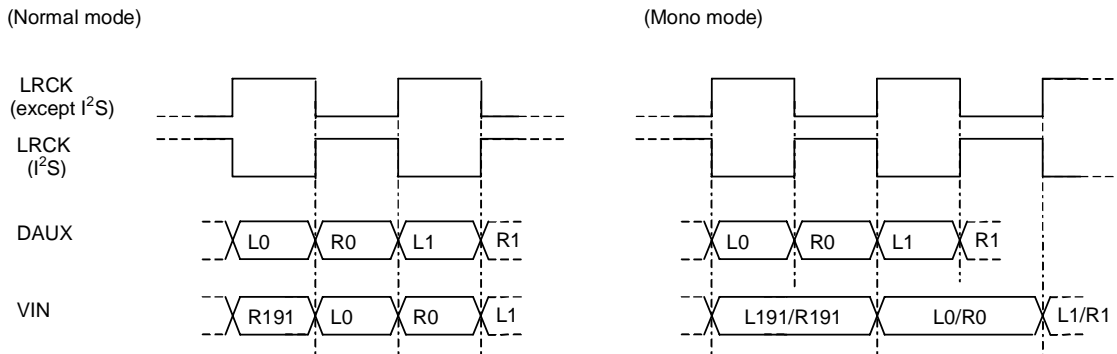

Figure 14. DAUX and VIN input timings

■ Double sampling frequency mode

When MONO bit = “1”, the AK4114 outputs data with double speed according to “Single channel double sampling frequency mode” of AES3. For example, when 192kHz mono data is transmitted or received, L/R channels of 96kHz biphas data are used. In this case, 1 frame is 96kHz and LRCK frequency is 192kHz.

1) RX

When MONO bit = “1”, AK4114 outputs mono data from SDTO as follows.

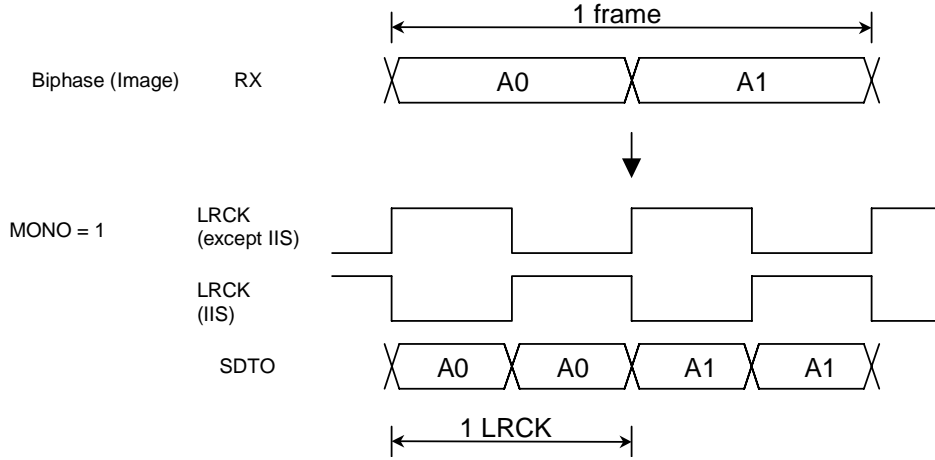

Figure 15. MONO mode (RX)

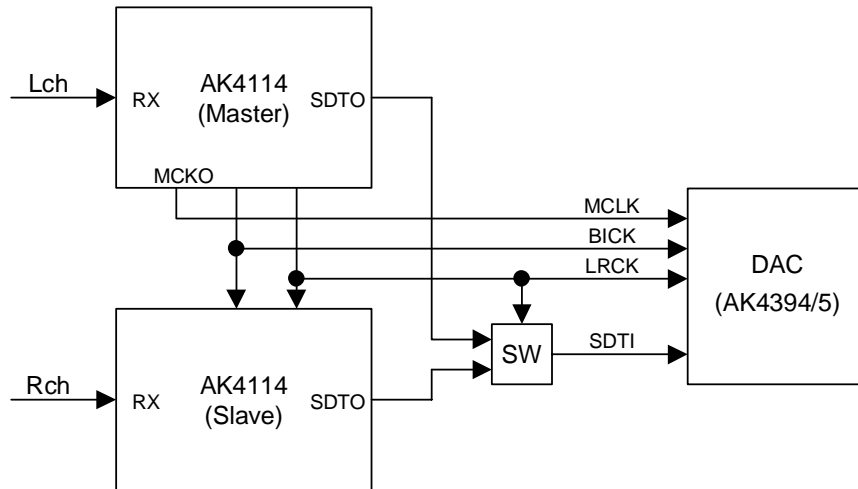

Figure 16. MONO mode Connection Example (RX)

2) TX

When MONO bit = "1" and TLR bit = "0", the AK4114 outputs Lch data through TX1 as biphasic signal. When MONO bit = "1" and TLR bit = "1", then Rch data.

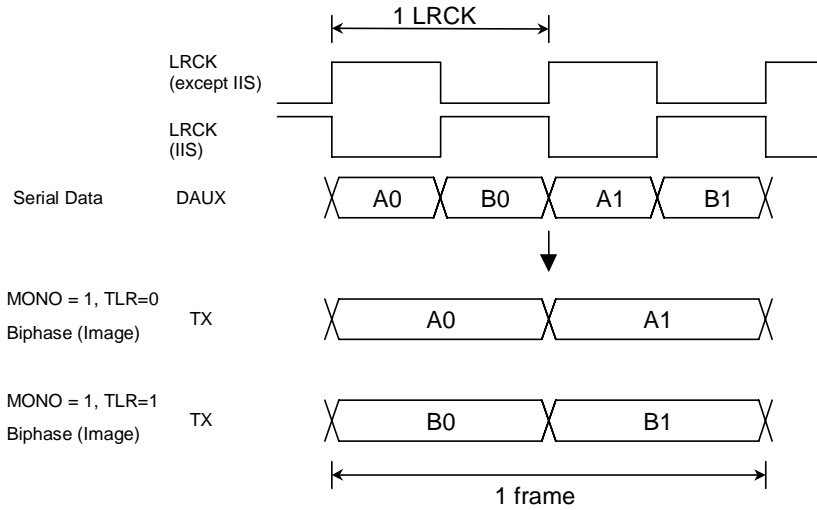

Figure 17. MONO mode (TX)

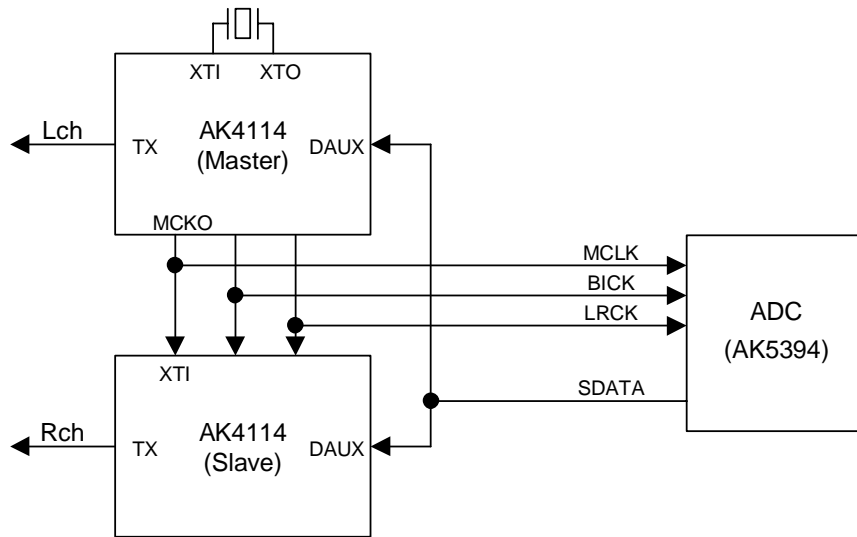
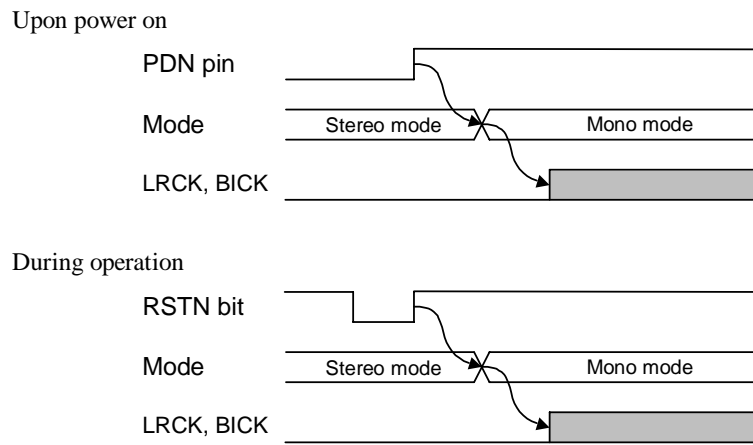

Figure 18. MONO mode Connection Example (TX)

Note: When the connection example (Figure 18) or multiple AK4114s are used, LRCK and BICK should be input after reset so that the phase of TX outputs is aligned. The AK4114s should be set by following sequence (Figure 19).



- (1) Reset all the AK4114s by PDN pin = “L” → “H” or RSTN bit = “0” → “1”.
- (2) Set all the AK4114s to MONO mode while they are still in slave mode.
- (3) Set one of the AK4114s to master mode so that LRCK is input to all other AK4114s at the same time, or LRCK should be input to all the AK4114s at the same time.

Figure 19. MONO mode setup sequence (TX)

■ Biphase signal input/output circuit

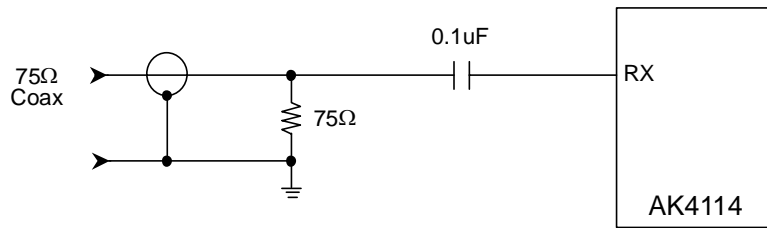

Figure 20. Consumer Input Circuit (Coaxial Input)

Note: In case of coaxial input, if a coupling level to this input from the next RX input line pattern exceeds 50mV, there is a possibility to occur an incorrect operation. In this case, it is possible to lower the coupling level by adding this decoupling capacitor.

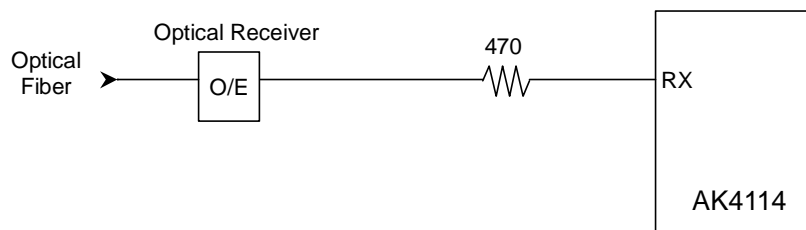

Figure 21. Consumer Input Circuit (Optical Input)

In case of coaxial input, as the input level of RX line is small, in Serial Mode, be careful not to crosstalk among RX input lines. For example, by inserting the shield pattern among them. In Parallel Mode, four channel inputs (RX0,1,2,3) are available and RX4-7 change to other pins for audio format control. Those pins must be fixed to “H” or “L”.

The AK4114 includes the TX output buffer. The output level meets combination 0.5V $\pm$ 20% using the external resistor network. The T1 in Figure 22 is a transformer of 1:1.

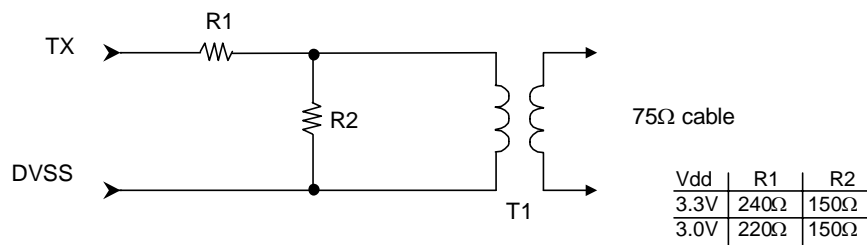
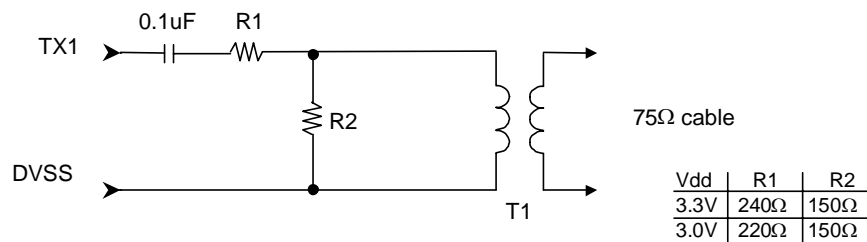

Figure 22. TX External Resistor Network

Note: When the AK4114 is in the power-down mode (PDN= “L”), power supply current can be suppressed by using AC couple capacitor as following figure since TX1 pin output becomes uncertain at power-down mode.



■ Q-subcode buffers

The AK4114 has Q-subcode buffer for CD application. The AK4114 takes Q-subcode into registers by following conditions.

1. The sync word (S0,S1) is constructed at least 16 “0”s.
2. The start bit is “1”.
3. Those 7bits Q-W follows to the start bit.
4. The distance between two start bits are 8-16 bits.

The QINT bit in the control register goes “1” when the new Q-subcode differs from old one, and goes “0” when QINT bit is read.

	1	2	3	4	5	6	7	8	*
S0	0	0	0	0	0	0	0	0	0...
S1	0	0	0	0	0	0	0	0	0...
S2	1	Q2	R2	S2	T2	U2	V2	W2	0...
S3	1	Q3	R3	S3	T3	U3	V3	W3	0...
:	:	:	:	:	:	:	:	:	:
S97	1	Q97	R97	S97	T97	U97	V97	W97	0...
S0	0	0	0	0	0	0	0	0	0...
S1	0	0	0	0	0	0	0	0	0...
S2	1	Q2	R2	S2	T2	U2	V2	W2	0...
S3	1	Q3	R3	S3	T3	U3	V3	W3	0...
:	:	:	:	:	:	:	:	:	:

(\*) number of "0" : min=0; max=8.  
 Figure 23. Configuration of U-bit(CD)

Q2	Q3	Q4	Q5	Q6	Q7	Q8	Q9	Q10	Q11	Q12	Q13	Q14	Q15	Q16	Q17	Q18	Q19	Q20	Q21	Q22	Q23	Q24	Q25
CTRL				ADRS				TRACK NUMBER								INDEX							
Q26	Q27	Q28	Q29	Q30	Q31	Q32	Q33	Q34	Q35	Q36	Q37	Q38	Q39	Q40	Q41	Q42	Q43	Q44	Q45	Q46	Q47	Q48	Q49
MINUTE							SECOND							FRAME									
Q50	Q51	Q52	Q53	Q54	Q55	Q56	Q57	Q58	Q59	Q60	Q61	Q62	Q63	Q64	Q65	Q66	Q67	Q68	Q69	Q70	Q71	Q72	Q73
ZERO							ABSOLUTE MINUTE								ABSOLUTE SECOND								
Q74	Q75	Q76	Q77	Q78	Q79	Q80	Q81	Q82	Q83	Q84	Q85	Q86	Q87	Q88	Q89	Q90	Q91	Q92	Q93	Q94	Q95	Q96	Q97
ABSOLUTE FRAME								CRC															

$G(x)=x^{16}+x^{12}+x^5+1$

Figure 24. Q-subcode

Addr	Register Name	D7	D6	D5	D4	D3	D2	D1	D0
	Q-subcode Address / Control	Q9	Q8	...	...	...	...	Q3	Q2
	Q-subcode Track	Q17	Q16	...	...	...	...	Q11	Q10
	Q-subcode Index	...	...	...	...	...	...	...	...
	Q-subcode Minute	...	...	...	...	...	...	...	...
	Q-subcode Second	...	...	...	...	...	...	...	...
	Q-subcode Frame	...	...	...	...	...	...	...	...
	Q-subcode Zero	...	...	...	...	...	...	...	...
	Q-subcode ABS Minute	...	...	...	...	...	...	...	...
	Q-subcode ABS Second	...	...	...	...	...	...	...	...
	Q-subcode ABS Frame	Q81	Q80	...	...	...	...	Q75	Q74

Figure 25. Q-subcode register

■ Error Handling

There are the following eight events who make INT0/1 pin “H”. INT0/1 pin shows the status of following conditions.

1. UNLOCK : “1” when the PLL loses lock.  
AK4114 loses lock when the distance between two preambles is not correct or when those preambles are not correct.
2. PAR : “1” when parity error or biphas coding error is detected, and keeps “1” until this register is read.  
Updated every sub-frame cycle. Reading this register resets itself.
3. AUTO : “1” when Non-PCM bitstream is detected.  
Updated every 4096 frames cycle.
4. DTSCD : “1” when DTS-CD bitstream is detected.  
Updated every DTS-CD sync cycle.
5. AUDION : “1” when the “AUDIO” bit in recovered channel status indicates “1”.  
Updated every block cycle.
6. PEM : “1” when “PEM” in recovered channel status indicates “1”.  
Updated every block cycle.
7. QINT : “1” when Q-subcode differ from old one, and keeps “1” until this register is read.  
Updated every sync code cycle for Q-subcode. Reading this register resets itself.
8. CINT : “1” when received C bits differ from old one, and keeps “1” until this register is read.  
Updated every block cycle. Reading this register resets itself.

Both INT0/1 are fixed to “L” when the PLL is off (CM1,0= “01”). Once the INT0 pin goes to “H”, this pin holds “H” for 1024/fs cycles(this value can be changed by EFH0/1 bits) after those events are removed. INT1 goes to “L” at the same time when those events are removed. Each INT0/1 pins can mask those eight events individually. Once PAR, QINT and CINT bit goes to “1”, those registers are held to “1” until those registers are read. While the AK4114 loses lock, registers regarding C-bit or U-bits are not initialized and keep previous value.

1. Parallel mode

In Parallel Mode, INT0 pin outputs the ORed signal between UNLOCK and PAR, INT1 pin outputs the ORed signal among AUTO, DTSCD and AUDION. Once INT0 pin goes ”H”, it maintains “H” for 1024/fs cycles after the all error events are removed. Table 12 shows the state of each output pins when the INT0/1 pin is “H”.

Event (State of Internal Register)					Pin				
UNLOCK	PAR	AUTO	DTSCD	AUDION	INT0	INT1	SDTO	V	TX
1	x	x	x	x	“H”	-	“L”	“L”	Output
0	1	x	x	Previous Data			Output		
0	0	x	x	Output			Output		
x	x	1	x	-	“H”	-	-		
x	x	x	1						
x	x	x	1						
x	x	0	0						
x	x	0	0	-	“L”	-	-	-	

Table 12. Error Handling (Parallel Mode) x: Don’t care



2. Serial mode

In Serial Mode, INT0/1 pin output the ORed signal among those eight events. However, each events can be masked by each mask bits. When each bit masks those events, the event does not affect INT0/1 pin operation (those mask do not affect those registers (UNLOCK, PAR, etc.) themselves. Once INT0 pin goes “H”, it maintains “H” for 1024/fs cycles (this value can be changed by EFH0-1 bits) after the all events are removed. Once those PAR, QINT or CINT bit goes “1”, it holds “1” until reading those registers. While the AK4114 loses lock, the channel status an Q-subcode bits are not updated and holds the previous data. At initial state, INT0 outputs the ORed signal between UNLOCK and PAR, INT1 outputs the ORed signal among AUTO, DTSCD and AUDION.

Register								Pin		
UNLOCK	PAR	AUTO	DTSCD	AUDION	PEM	QINT	CINT	SDTO	V	TX
1	x	x	x	x	x	x	x	“L”	“L”	Output
0	1	x	x	x	x	x	x	Previous Data	Output	Output
0	0	1	x	x	x	x	x	Output	Output	Output
0	0	x	1	x	x	x	x	Output	Output	Output
0	0	x	x	1	x	x	x	Output	Output	Output
0	0	x	x	x	1	x	x	Output	Output	Output
0	0	x	x	x	x	1	x	Output	Output	Output
0	0	x	x	x	x	x	1	Output	Output	Output

Table 13. Error Handling (Serial Mode)

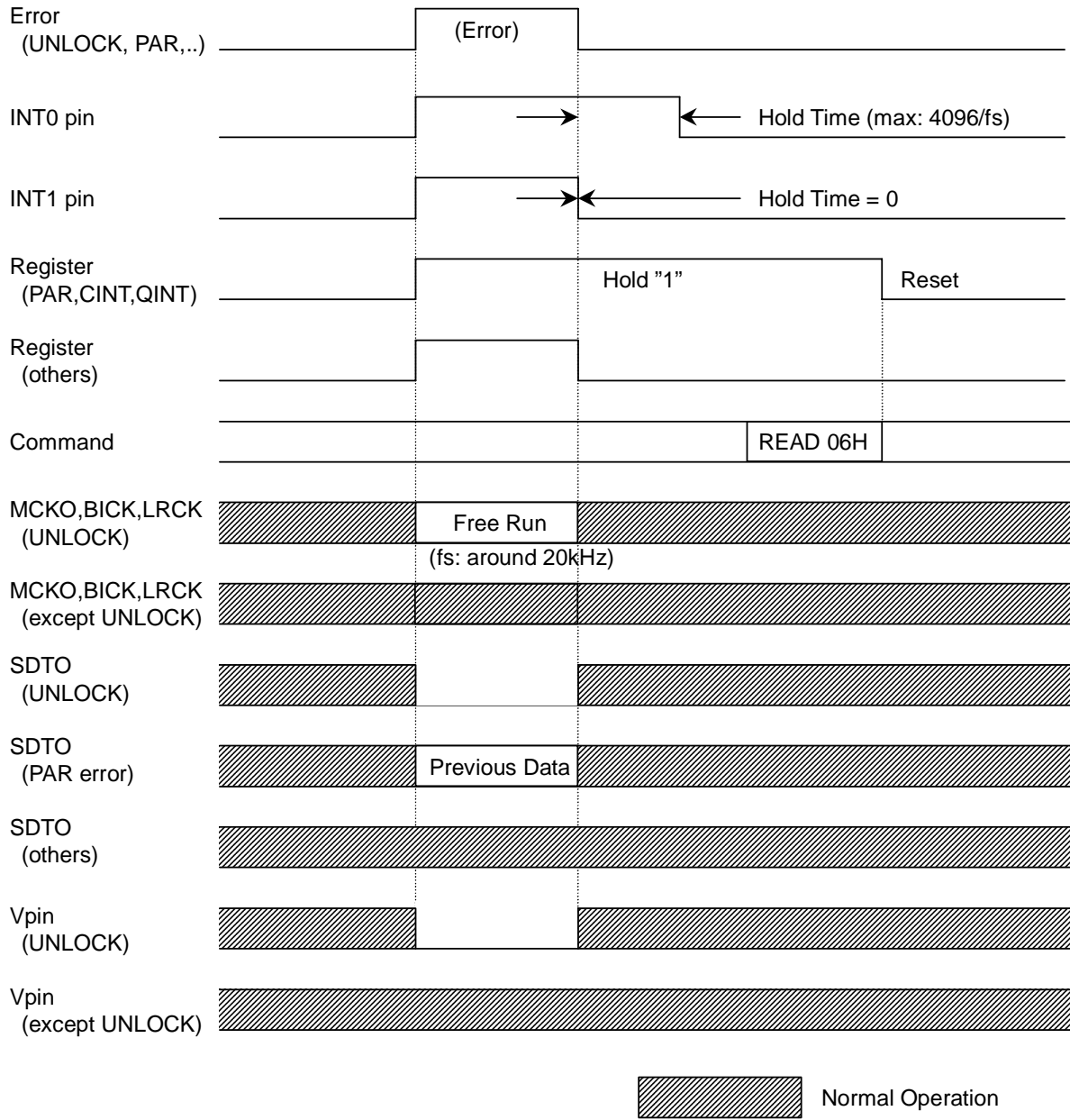

Figure 26. INT0/1 pin timing

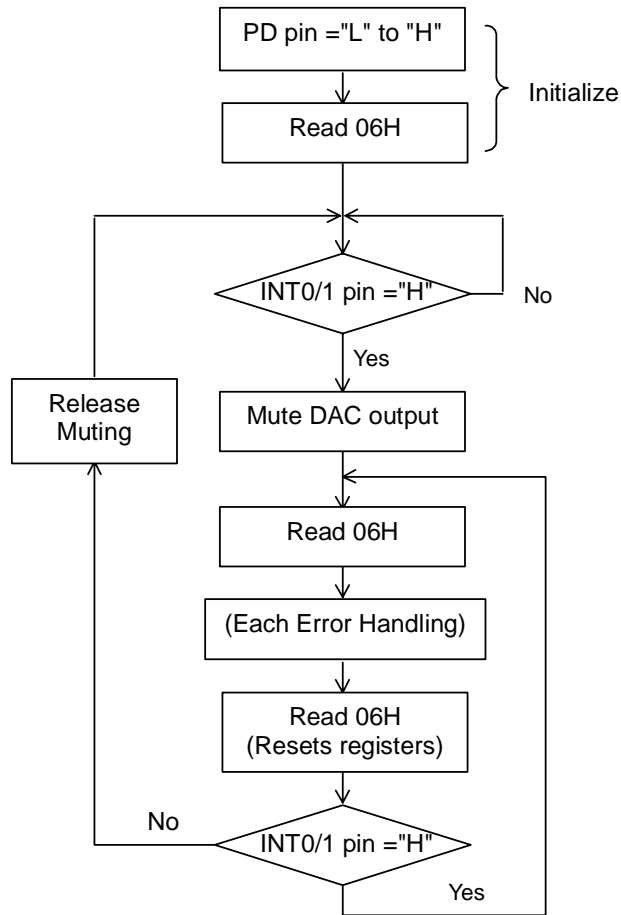

Figure 27. Error Handling Sequence Example 1

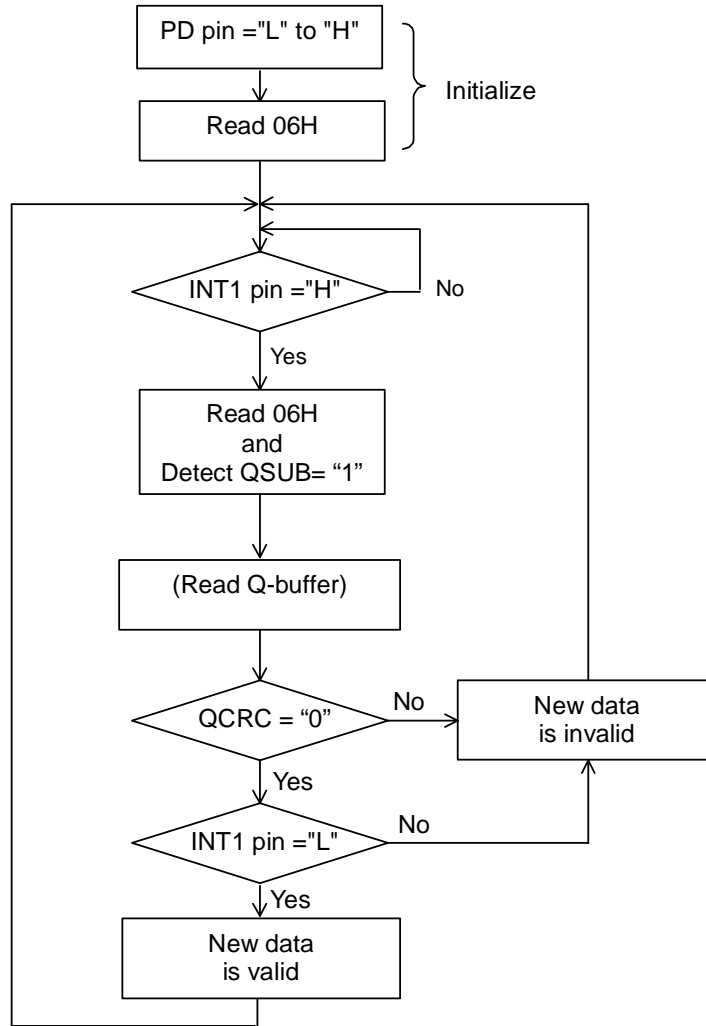

Figure 28. Error Handling Sequence Example (for Q/CINT)

■ Audio Serial Interface Format

The DIF0, DIF1 and DIF2 pins can select eight serial data formats as shown in Table 14. In all formats the serial data is MSB-first, 2's compliment format. The SDTO is clocked out on the falling edge of BICK and the DAUX is latched on the rising edge of BICK. BICK outputs 64fs clock in Mode 0-5. Mode 6-7 are Slave Modes, and BICK is available up to 128fs at fs=48kHz. In the format equal or less than 20bit (Mode0-2), LSBs in sub-frame are truncated. In Mode 3-7, the last 4LSBs are auxiliary data (see Figure 29).

When the Parity Error, Biphas Error or Frame Length Error occurs in a sub-frame, AK4114 continues to output the last normal sub-frame data from SDTO repeatedly until the error is removed. When the Unlock Error occurs, AK4114 output "0" from SDTO. In case of using DAUX pin, the data is transformed and output from SDTO. DAUX pin is used in Clock Operation Mode 1, 3 and unlock state of Mode 2.

The input data format to DAUX should be left justified except in Mode5 and 7(Table 14). In Mode5 or 7, both the input data format of DAUX and output data format of SDTO are I<sup>2</sup>S. Mode6 and 7 are Slave Mode that is corresponding to the Master Mode of Mode4 and 5. In salve Mode, LRCK and BICK should be fed with synchronizing to MCKO1/2.

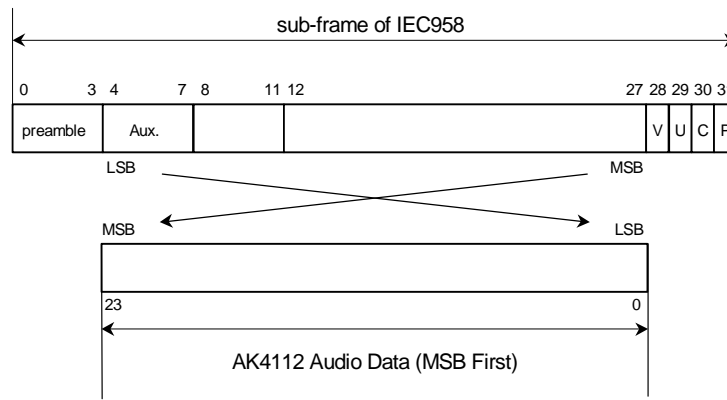

Figure 29. Bit configuration

Mode	DIF2	DIF1	DIF0	DAUX	SDTO	LRCK		BICK	
							I/O		I/O
0	0	0	0	24bit, Left justified	16bit, Right justified	H/L	O	64fs	O
1	0	0	1	24bit, Left justified	18bit, Right justified	H/L	O	64fs	O
2	0	1	0	24bit, Left justified	20bit, Right justified	H/L	O	64fs	O
3	0	1	1	24bit, Left justified	24bit, Right justified	H/L	O	64fs	O
4	1	0	0	24bit, Left justified	24bit, Left justified	H/L	O	64fs	O
5	1	0	1	24bit, I <sup>2</sup> S	24bit, I <sup>2</sup> S	L/H	O	64fs	O
6	1	1	0	24bit, Left justified	24bit, Left justified	H/L	I	64-128fs	I
7	1	1	1	24bit, I <sup>2</sup> S	24bit, I <sup>2</sup> S	L/H	I	64-128fs	I

Default

Table 14. Audio data format

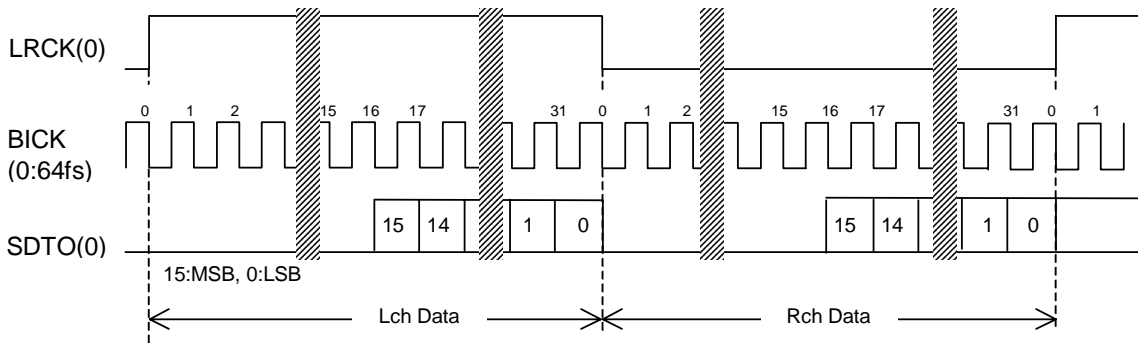

Figure 30. Mode 0 Timing

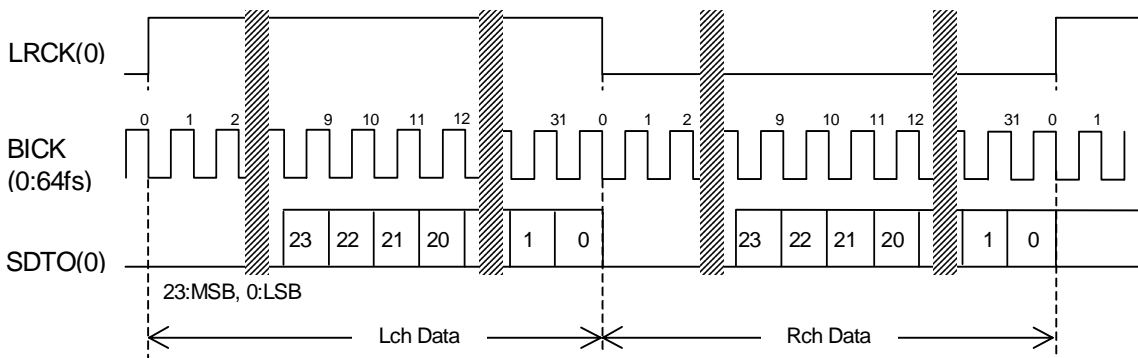

Figure 31. Mode 3 Timing

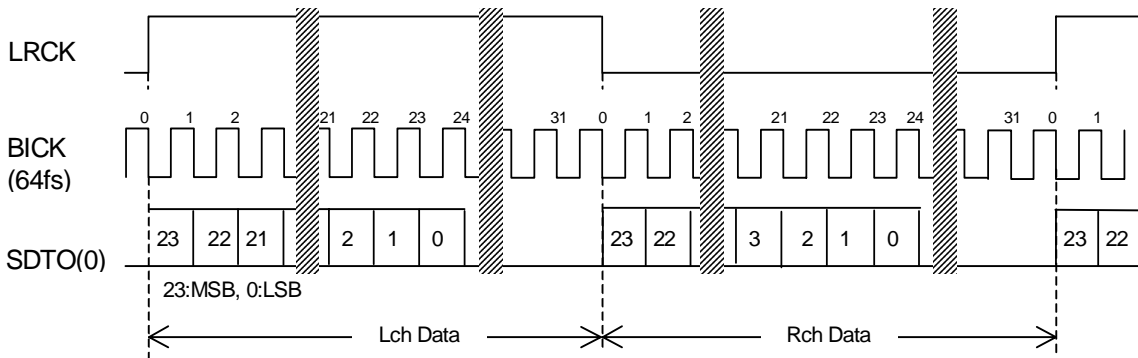

Figure 32. Mode 4, 6 Timing

Mode4 : LRCK, BICK : Output  
 Mode6 : LRCK, BICK : Input

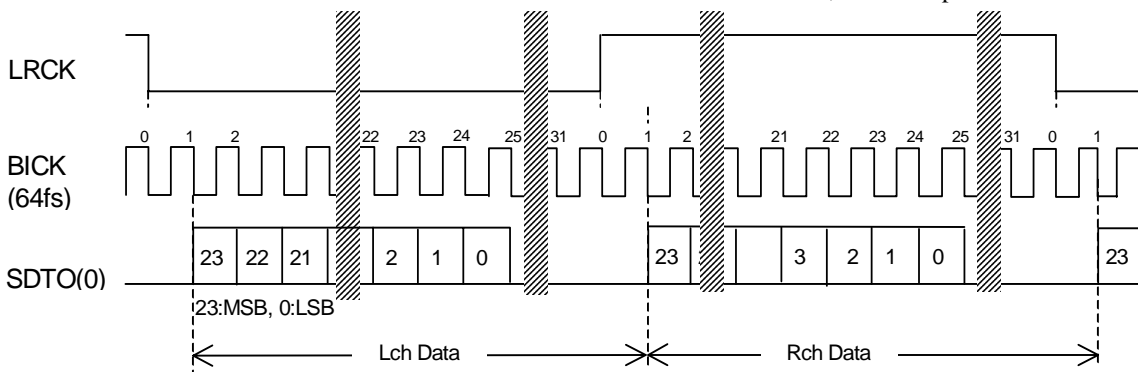

Figure 33. Mode 5, 7 Timing

Mode5 : LRCK, BICK : Output  
 Mode7 : LRCK, BICK : Input

■ Serial Control Interface

(1). 4-wire serial control mode (IIC= “L”)

The internal registers may be either written or read by the 4-wire  $\mu$ P interface pins: CSN, CCLK, CDTI & CDTO. The data on this interface consists of Chip address (2bits, C1-0 are fixed to “00”), Read/Write (1bit), Register address (MSB first, 5bits) and Control data (MSB first, 8bits). Address and data is clocked in on the rising edge of CCLK and data is clocked out on the falling edge. For write operations, data is latched after the 16th rising edge of CCLK, after a high-to-low transition of CSN. For read operations, the CDTO output goes high impedance after a low-to-high transition of CSN. The maximum speed of CCLK is 5MHz. PDN= “L” resets the registers to their default values. When the state of P/S pin is changed, the AK4114 should be reset by PDN= “L”.

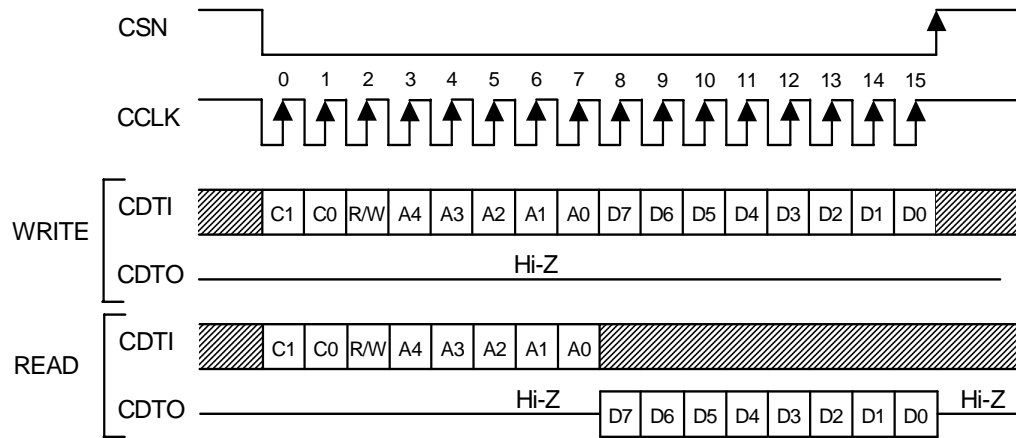

C1-C0: Chip Address (Fixed to “00”)  
 R/W: READ/WRITE (0:READ, 1:WRITE)  
 A4-A0: Register Address  
 D7-D0: Control Data

Figure 34. 4-wire Serial Control I/F Timing

(2). I<sup>2</sup>C bus control mode (IIC= "H")

AK4114 supports the standard-mode I<sup>2</sup>C-bus (max : 100kHz). Then AK4114 can not be incorporated in a fast-mode I<sup>2</sup>C-bus system (max : 400kHz).

(2)-1. Data transfer

All commands are preceded by a START condition. After the START condition, a slave address is sent. After the AK4114 recognizes the START condition, the device interfaced to the bus waits for the slave address to be transmitted over the SDA line. If the transmitted slave address matches an address for one of the devices, the designated slave device pulls the SDA line to LOW (ACKNOWLEDGE). The data transfer is always terminated by a STOP condition generated by the master device.

(2)-1-1. Data validity

The data on the SDA line must be stable during the HIGH period of the clock. The HIGH or LOW state of the data line can only change when the clock signal on the SCL line is LOW except for the START and the STOP condition.

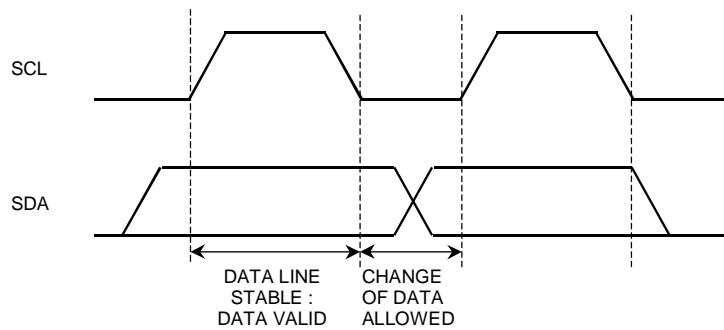

Figure 35. Data transfer

(2)-1-2. START and STOP condition

A HIGH to LOW transition on the SDA line while SCL is HIGH indicates a START condition. All sequences start from the START condition.

A LOW to HIGH transition on the SDA line while SCL is HIGH defines a STOP condition. All sequences end by the STOP condition.

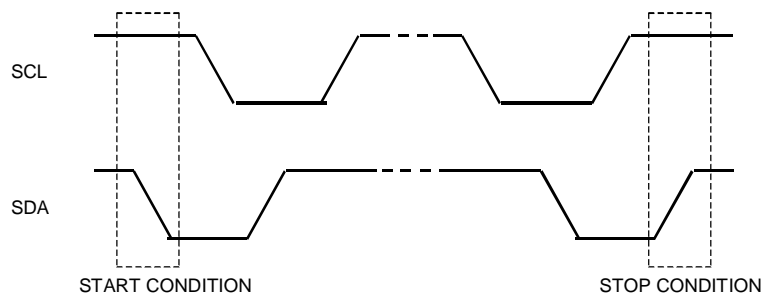

Figure 36. START and STOP conditions



(2)-1-3. ACKNOWLEDGE

ACKNOWLEDGE is a software convention used to indicate successful data transfers. The transmitting device will release the SDA line (HIGH) after transmitting eight bits. The receiver must pull down the SDA line during the acknowledge clock pulse so that that it remains stable “L” during “H” period of this clock pulse. The AK4114 will generate an acknowledge after each byte has been received.

In the read mode, the slave, AK4114 will transmit eight bits of data, release the SDA line and monitor the line for an acknowledge. If an acknowledge is detected and no STOP condition is generated by the master, the slave will continue to transmit data. If an acknowledge is not detected, the slave will terminate further data transmissions and await the STOP condition.

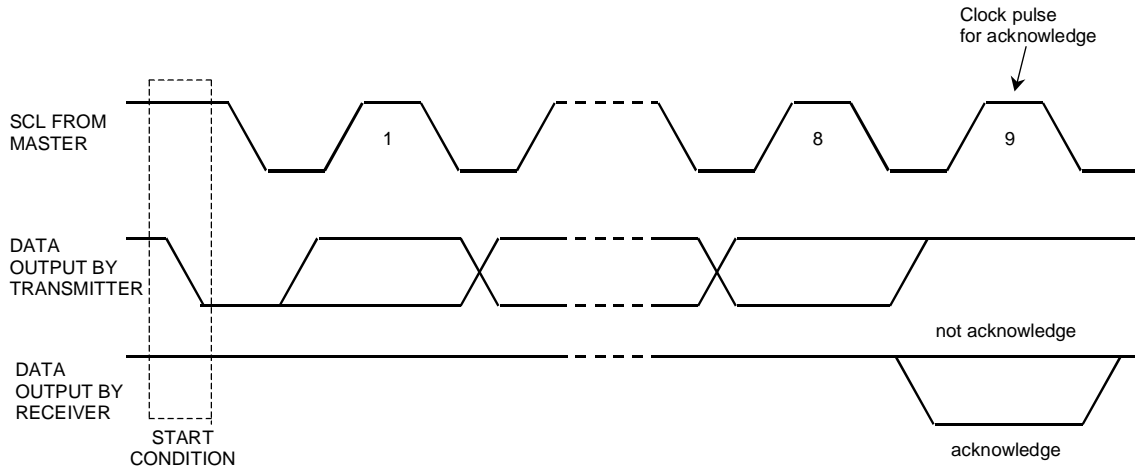
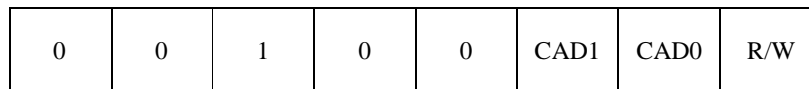

Figure 37. Acknowledge on the I<sup>2</sup>C-bus

(2)-1-4. FIRST BYTE

The first byte, which includes seven bits of slave address and one bit of R/W bit, is sent after the START condition. If the transmitted slave address matches an address for one of the device, the receiver who has been addressed pulls down the SDA line.

The most significant five bits of the slave address are fixed as “00100”. The next two bits are CAD1 and CAD0 (device address bits). These two bits identify the specific device on the bus. The hard-wired input pins (CAD1 pin and CAD0 pin) set them. The eighth bit (LSB) of the first byte (R/W bit) defines whether a write or read condition is requested by the master. A “1” indicates that the read operation is to be executed. A “0” indicates that the write operation is to be executed.



(Those CAD1/0 should match with CAD1/0 pins.)

Figure 38. The First Byte

(2)-2. WRITE Operations

Set R/W bit = "0" for the WRITE operation of AK4114.

After receipt the start condition and the first byte, the AK4114 generates an acknowledge, and awaits the second byte (register address). The second byte consists of the address for control registers of AK4114. The format is MSB first, and those most significant 3-bits are "Don't care".

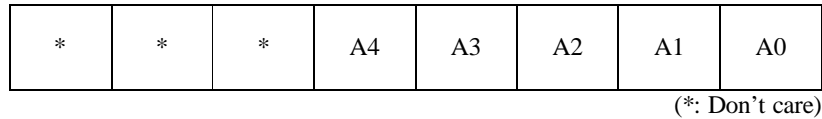

Figure 39. The Second Byte

After receipt the second byte, the AK4114 generates an acknowledge, and awaits the third byte. Those data after the second byte contain control data. The format is MSB first, 8bits.

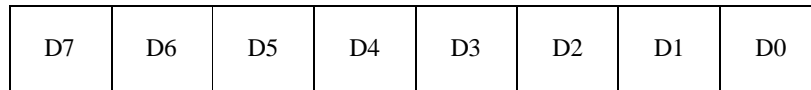

Figure 40. Byte structure after the second byte

The AK4114 is capable of more than one byte write operation by one sequence.

After receipt of the third byte, the AK4114 generates an acknowledge, and awaits the next data again. The master can transmit more than one words instead of terminating the write cycle after the first data word is transferred. After the receipt of each data, the internal 5bits address counter is incremented by one, and the next data is taken into next address automatically. If the address exceed 1FH prior to generating the stop condition, the address counter will "roll over" to 00H and the previous data will be overwritten.

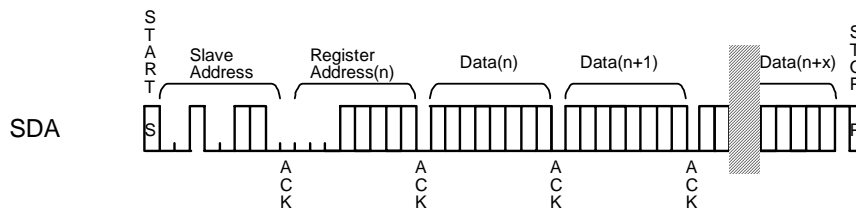

Figure 41. WRITE Operation

(2)-3. READ Operations

Set R/W bit = “1” for the READ operation of AK4114.

After transmission of a data, the master can read next address’s data by generating the acknowledge instead of terminating the write cycle after the receipt the first data word. After the receipt of each data, the internal 5bits address counter is incremented by one, and the next data is taken into next address automatically. If the address exceed 1FH prior to generating the stop condition, the address counter will “roll over” to 00H and the previous data will be overwritten.

The AK4114 supports two basic read operations: CURRENT ADDRESS READ and RANDOM READ.

(2)-3-1. CURRENT ADDRESS READ

The AK4114 contains an internal address counter that maintains the address of the last word accessed, incremented by one. Therefore, if the last access (either a read or write) was to address n, the next CURRENT READ operation would access data from the address n+1.

After receipt of the slave address with R/W bit set to “1”, the AK4114 generates an acknowledge, transmits 1byte data which address is set by the internal address counter and increments the internal address counter by 1. If the master does not generate an acknowledge to the data but generate the stop condition, the AK4114 discontinues transmission

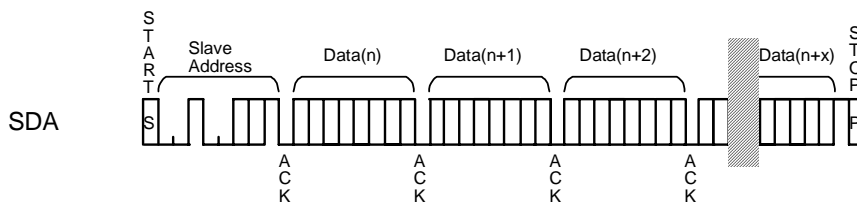

Figure 42. CURRENT ADDRESS READ

(2)-3-2. RANDOM READ

Random read operation allows the master to access any memory location at random. Prior to issuing the slave address with the R/W bit set to “1”, the master must first perform a “dummy” write operation.

The master issues the start condition, slave address(R/W=“0”) and then the register address to read. After the register address’s acknowledge, the master immediately reissues the start condition and the slave address with the R/W bit set to “1”. Then the AK4114 generates an acknowledge, 1byte data and increments the internal address counter by 1. If the master does not generate an acknowledge to the data but generate the stop condition, the AK4114 discontinues transmission.

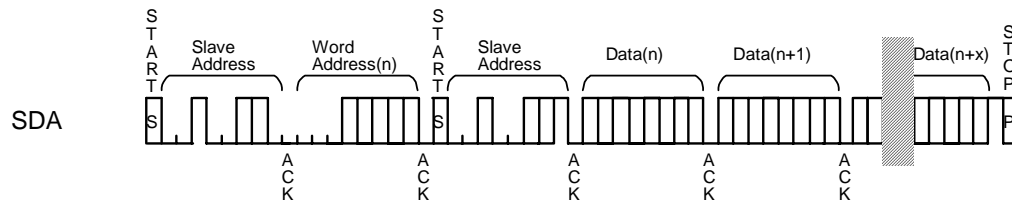

Figure 43. RANDOM READ

## ■ Register Map

Addr	Register Name	D7	D6	D5	D4	D3	D2	D1	D0
00H	CLK & Power Down Control	CS12	BCU	CM1	CM0	OCKS1	OCKS0	PWN	RSTN
01H	Format & De-em Control	MONO	DIF2	DIF1	DIF0	DEAU	DEM1	DEM0	DFS
02H	Input/ Output Control 0	TX1E	OPS12	OPS11	OPS10	TX0E	OPS02	OPS01	OPS00
03H	Input/ Output Control 1	EFH1	EFH0	UDIT	TLR	DIT	IPS2	IPS1	IPS0
04H	INT0 MASK	MQIT0	MAUT0	MCIT0	MULK0	MDTS0	MPE0	MAUD0	MPAR0
05H	INT1 MASK	MQIT1	MAUT1	MCIT1	MULK1	MDTS1	MPE1	MAUD1	MPAR1
06H	Receiver status 0	QINT	AUTO	CINT	UNLCK	DTSCD	PEM	AUDION	PAR
07H	Receiver status 1	FS3	FS2	FS1	FS0	0	V	QCRC	CCRC
08H	RX Channel Status Byte 0	CR7	CR6	CR5	CR4	CR3	CR2	CR1	CR0
09H	RX Channel Status Byte 1	CR15	CR14	CR13	CR12	CR11	CR10	CR9	CR8
0AH	RX Channel Status Byte 2	CR23	CR22	CR21	CR20	CR19	CR18	CR17	CR16
0BH	RX Channel Status Byte 3	CR31	CR30	CR29	CR28	CR27	CR26	CR25	CR24
0CH	RX Channel Status Byte 4	CR39	CR38	CR37	CR36	CR35	CR34	CR33	CR32
0DH	TX Channel Status Byte 0	CT7	CT6	CT5	CT4	CT3	CT2	CT1	CT0
0EH	TX Channel Status Byte 1	CT15	CT14	CT13	CT12	CT11	CT10	CT9	CT8
0FH	TX Channel Status Byte 2	CT23	CT22	CT21	CT20	CT19	CT18	CT17	CT16
10H	TX Channel Status Byte 3	CT31	CT30	CT29	CT28	CT27	CT26	CT25	CT24
11H	TX Channel Status Byte 4	CT39	CT39	CT39	CT39	CT39	CT39	CT39	CT32
12H	Burst Preamble Pc Byte 0	PC7	PC6	PC5	PC4	PC3	PC2	PC1	PC0
13H	Burst Preamble Pc Byte 1	PC15	PC14	PC13	PC12	PC11	PC10	PC9	PC8
14H	Burst Preamble Pd Byte 0	PD7	PD6	PD5	PD4	PD3	PD2	PD1	PD0
15H	Burst Preamble Pd Byte 1	PD15	PD14	PD13	PD12	PD11	PD10	PD9	PD8
16H	Q-subcode Address / Control	Q9	Q8	Q7	Q6	Q5	Q4	Q3	Q2
17H	Q-subcode Track	Q17	Q16	Q15	Q14	Q13	Q12	Q11	Q10
18H	Q-subcode Index	Q25	Q24	Q23	Q22	Q21	Q20	Q19	Q18
19H	Q-subcode Minute	Q33	Q32	Q31	Q30	Q29	Q28	Q27	Q26
1AH	Q-subcode Second	Q41	Q40	Q39	Q38	Q37	Q36	Q35	Q34
1BH	Q-subcode Frame	Q49	Q48	Q47	Q46	Q45	Q44	Q43	Q42
1CH	Q-subcode Zero	Q57	Q56	Q55	Q54	Q53	Q52	Q51	Q50
1DH	Q-subcode ABS Minute	Q65	Q64	Q63	Q62	Q61	Q60	Q59	Q58
1EH	Q-subcode ABS Second	Q73	Q72	Q71	Q70	Q69	Q68	Q67	Q66
1FH	Q-subcode ABS Frame	Q81	Q80	Q79	Q78	Q77	Q76	Q75	Q74

When PDN pin goes “L”, the registers are initialized to their default values.

When RSTN bit goes “0”, the internal timing is reset and the registers are initialized to their default values.

All data can be written to the register even if PWN bit is “0”.

■ Register Definitions

Reset & Initialize

Addr	Register Name	D7	D6	D5	D4	D3	D2	D1	D0
00H	CLK & Power Down Control	CS12	BCU	CM1	CM0	OCKS1	OCKS0	PWN	RSTN
	R/W	R/W	R/W	R/W	R/W	R/W	R/W	R/W	R/W
	Default	0	1	0	0	0	0	1	1

RSTN: Timing Reset & Register Initialize

0: Reset & Initialize

1: Normal Operation

PWN: Power Down

0: Power Down

1: Normal Operation

OCKS1-0: Master Clock Frequency Select

CM1-0: Master Clock Operation Mode Select

BCU: Block start & C/U Output Mode

When BCU=1, the three Output Pins(BOUT, COUT, UOUT) become to be enabled.

The block signal goes high at the start of frame 0 and remains high until the end of frame 31.

CS12: Channel Status Select

0: Channel 1

1: Channel 2

Selects which channel status is used to derive C-bit buffers, AUDION, PEM, FS3, FS2, FS1, FS0, Pc and Pd. The de-emphasis filter is controlled by channel 1 in the Parallel Mode.

Format & De-emphasis Control

Addr	Register Name	D7	D6	D5	D4	D3	D2	D1	D0
01H	Format & De-em Control	MONO	DIF2	DIF1	DIF0	DEAU	DEM1	DEM0	DFS
	R/W	R/W	R/W	R/W	R/W	R/W	R/W	R/W	R/W
	Default	0	1	1	0	1	0	1	0

DFS: 96kHz De-emphasis Control

DEM1-0: 32, 44.1, 48kHz De-emphasis Control (see Table 8.)

DEAU: De-emphasis Auto Detect Enable

0: Disable

1: Enable

DIF2-0: Audio Data Format Control (see Table 14.)

MONO: Double sampling frequency mode enable

0: Stereo mode

1: Mono mode

**Input/Output Control**

Addr	Register Name	D7	D6	D5	D4	D3	D2	D1	D0
02H	Input/ Output Control 0	TX1E	OPS12	OPS11	OPS10	TX0E	OPS02	OPS01	OPS00
	R/W	R/W	R/W	R/W	R/W	R/W	R/W	R/W	R/W
	Default	1	0	0	0	1	0	0	0

OPS02-00: Output Through Data Select for TX0 pin

OPS12-10: Output Through Data Select for TX1 pin

TX0E: TX0 Output Enable

0: Disable. TX0 outputs "L".

1: Enable

TX1E: TX1 Output Enable

0: Disable. TX1 outputs "L".

1: Enable

Addr	Register Name	D7	D6	D5	D4	D3	D2	D1	D0
03H	Input/ Output Control 1	EFH1	EFH0	UDIT	TLR	DIT	IPS2	IPS1	IPS0
	R/W	R/W	R/W	R/W	R/W	R/W	R/W	R/W	R/W
	Default	0	1	0	0	1	0	0	0

IPS2-0: Input Recovery Data Select

DIT: Through data/Transmit data select for TX1 pin

0: Through data (RX data).

1: Transmit data (DAUX data).

TLR: Double sampling frequency mode channel select for DIT(stereo)

0: L channel

1: R channel

UDIT: U bit control for DIT

0: U bit is fixed to "0"

1: Recovered U bit is used for DIT (loop mode for U bit)

EFH1-0: Interrupt 0 Pin Hold Count Select

00: 512 LRCK

01: 1024 LRCK

10: 2048 LRCK

11: 4096 LRCK

**Mask Control for INT0**

Addr	Register Name	D7	D6	D5	D4	D3	D2	D1	D0
04H	INT0 MASK	MQI0	MAT0	MCI0	MUL0	MDTS0	MPE0	MAN0	MPR0
	R/W	R/W	R/W	R/W	R/W	R/W	R/W	R/W	R/W
	Default	1	1	1	0	1	1	1	0

- MPR0: Mask Enable for PAR bit
- MAN0: Mask Enable for AUDN bit
- MPE0: Mask Enable for PEM bit
- MDTS0: Mask Enable for DTSCD bit
- MUL0: Mask Enable for UNLOCK bit
- MCI0: Mask Enable for CINT bit
- MAT0: Mask Enable for AUTO bit
- MQI0: Mask Enable for QINT bit

0: Mask disable  
 1: Mask enable

**Mask Control for INT1**

Addr	Register Name	D7	D6	D5	D4	D3	D2	D1	D0
05H	INT1 MASK	MQI1	MAT1	MCI1	MUL1	MDTS1	MPE1	MAN1	MPR1
	R/W	R/W	R/W	R/W	R/W	R/W	R/W	R/W	R/W
	Default	1	0	1	1	0	1	0	1

- MPR1: Mask Enable for PAR bit
- MAN1: Mask Enable for AUDN bit
- MPE1: Mask Enable for PEM bit
- MDTS1: Mask Enable for DTSCD bit
- MUL1: Mask Enable for UNLOCK0 bit
- MCI1: Mask Enable for CINT bit
- MAT1: Mask Enable for AUTO bit
- MQI1: Mask Enable for QINT bit

0: Mask disable  
 1: Mask enable





**Receiver Channel Status**

Addr	Register Name	D7	D6	D5	D4	D3	D2	D1	D0
08H	RX Channel Status Byte 0	CR7	CR6	CR5	CR4	CR3	CR2	CR1	CR0
09H	RX Channel Status Byte 1	CR15	CR14	CR13	CR12	CR11	CR10	CR9	CR8
0AH	RX Channel Status Byte 2	CR23	CR22	CR21	CR20	CR19	CR18	CR17	CR16
0BH	RX Channel Status Byte 3	CR31	CR30	CR29	CR28	CR27	CR26	CR25	CR24
0CH	RX Channel Status Byte 4	CR39	CR38	CR37	CR36	CR35	CR34	CR33	CR32
R/W		RD							
Default		Not initialized							

CR39-0: Receiver Channel Status Byte 4-0

**Transmitter Channel Status**

Addr	Register Name	D7	D6	D5	D4	D3	D2	D1	D0
0DH	TX Channel Status Byte 0	CT7	CT6	CT5	CT4	CT3	CT2	CT1	CT0
0EH	TX Channel Status Byte 1	CT15	CT14	CT13	CT12	CT11	CT10	CT9	CT8
0FH	TX Channel Status Byte 2	CT23	CT22	CT21	CT20	CT19	CT18	CT17	CT16
10H	TX Channel Status Byte 3	CT31	CT30	CT29	CT28	CT27	CT26	CT25	CT24
11H	TX Channel Status Byte 3	CT39	CT38	CT37	CT36	CT35	CT34	CT33	CT32
R/W		R/W							
Default		0							

CT39-0: Transmitter Channel Status Byte 4-0

**Burst Preamble Pc/Pd in non-PCM encoded Audio Bitstreams**

Addr	Register Name	D7	D6	D5	D4	D3	D2	D1	D0
12H	Burst Preamble Pc Byte 0	PC7	PC6	PC5	PC4	PC3	PC2	PC1	PC0
13H	Burst Preamble Pc Byte 1	PC15	PC14	PC13	PC12	PC11	PC10	PC9	PC8
14H	Burst Preamble Pd Byte 0	PD7	PD6	PD5	PD4	PD3	PD2	PD1	PD0
15H	Burst Preamble Pd Byte 1	PD15	PD14	PD13	PD12	PD11	PD10	PD9	PD8
R/W		RD							
Default		Not initialized							

PC15-0: Burst Preamble Pc Byte 0 and 1

PD15-0: Burst Preamble Pd Byte 0 and 1

**Q-subcode Buffer**

Addr	Register Name	D7	D6	D5	D4	D3	D2	D1	D0
16H	Q-subcode Address / Control	Q9	Q8	Q7	Q6	Q5	Q4	Q3	Q2
17H	Q-subcode Track	Q17	Q16	Q15	Q14	Q13	Q12	Q11	Q10
18H	Q-subcode Index	Q25	Q24	Q23	Q22	Q21	Q20	Q19	Q18
19H	Q-subcode Minute	Q33	Q32	Q31	Q30	Q29	Q28	Q27	Q26
1AH	Q-subcode Second	Q41	Q40	Q39	Q38	Q37	Q36	Q35	Q34
1BH	Q-subcode Frame	Q49	Q48	Q47	Q46	Q45	Q44	Q43	Q42
1CH	Q-subcode Zero	Q57	Q56	Q55	Q54	Q53	Q52	Q51	Q50
1DH	Q-subcode ABS Minute	Q65	Q64	Q63	Q62	Q61	Q60	Q59	Q58
1EH	Q-subcode ABS Second	Q73	Q72	Q71	Q70	Q69	Q68	Q67	Q66
1FH	Q-subcode ABS Frame	Q81	Q80	Q79	Q78	Q77	Q76	Q75	Q74
R/W		RD							
Default		Not initialized							

■ Burst Preambles in non-PCM Bitstreams

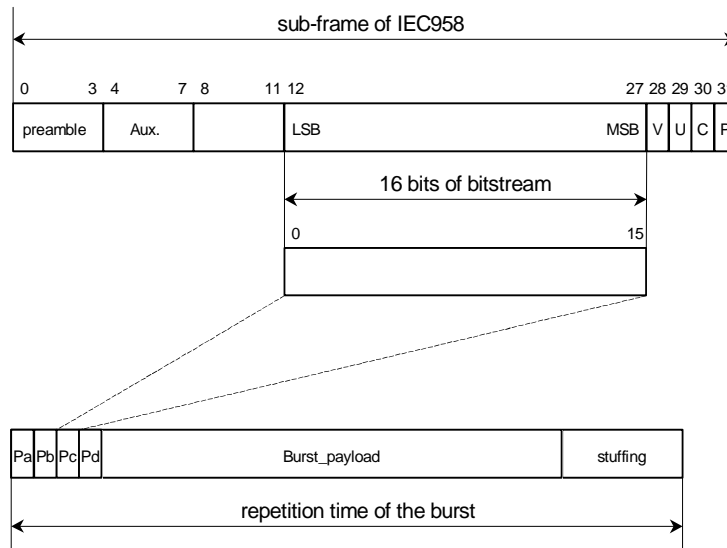

Figure 44. Data structure in IEC60958

Preamble word	Length of field	Contents	Value
Pa	16 bits	sync word 1	0xF872
Pb	16 bits	sync word 2	0x4E1F
Pc	16 bits	Burst info	See Table 16
Pd	16 bits	Length code	Numbers of bits

Table 15. Burst preamble words

Bits of Pc	Value	Contents	Repetition time of burst in IEC60958 frames
0-4		data type	
	0	NULL data	≤4096
	1	Dolby AC-3 data	1536
	2	reserved	
	3	PAUSE	
	4	MPEG-1 Layer1 data	384
	5	MPEG-1 Layer2 or 3 data or MPEG-2 without extension	1152
	6	MPEG-2 data with extension	1152
	7	MPEG-2 AAC ADTS	1024
	8	MPEG-2, Layer1 Low sample rate	384
	9	MPEG-2, Layer2 or 3 Low sample rate	1152
	10	reserved	
	11	DTS type I	512
	12	DTS type II	1024
	13	DTS type III	2048
	14	ATRAC	512
15	ATRAC2/3	1024	
16-31	reserved		
5, 6	0	reserved, shall be set to "0"	
7	0	error-flag indicating a valid burst_payload	
	1	error-flag indicating that the burst_payload may contain errors	
8-12		data type dependent info	
13-15	0	bit stream number, shall be set to "0"	

Table 16. Fields of burst info Pc

■ Non-PCM Bitstream timing

1) When Non-PCM preamble is not coming within 4096 frames,

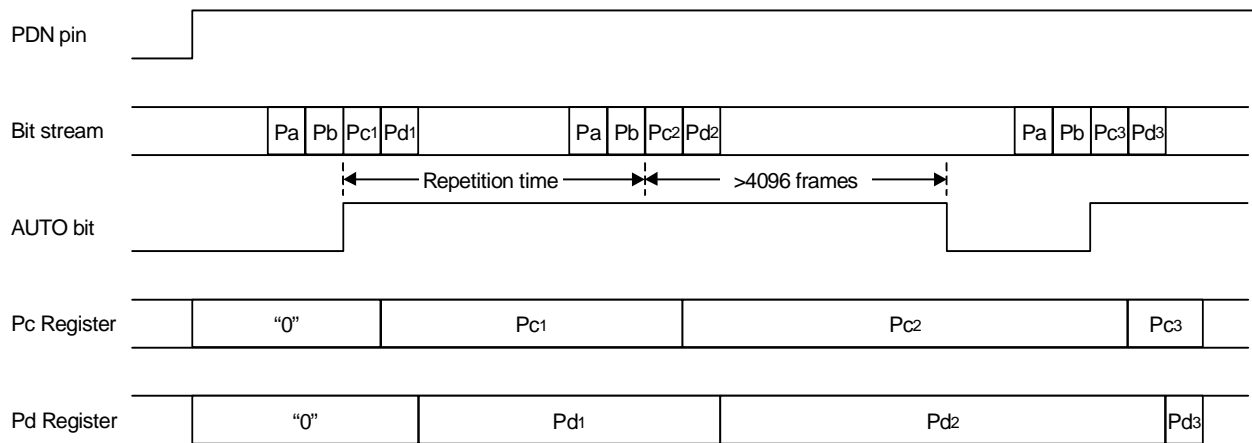

Figure 45. Timing example 1

2) When Non-PCM bitstream stops (when MULK0=0),

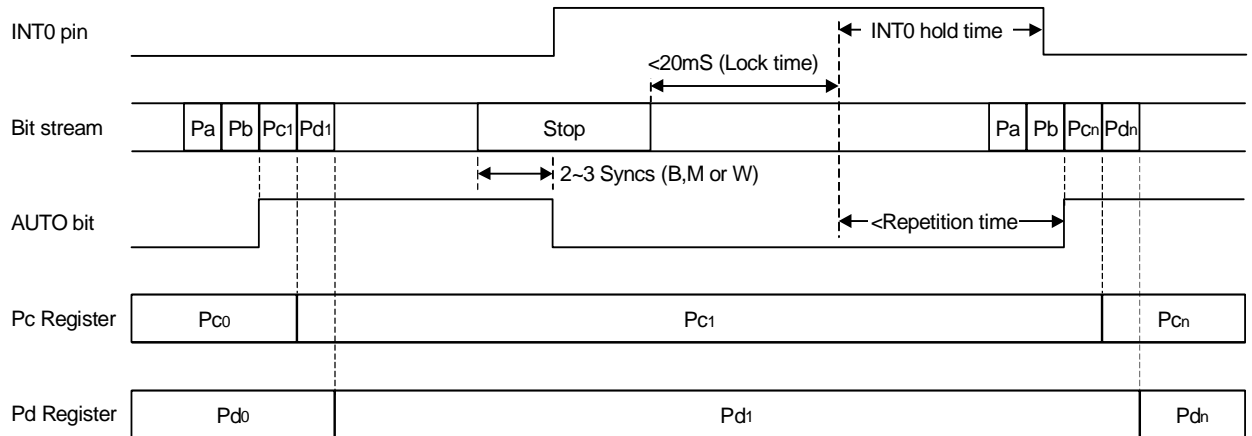

Figure 46. Timing example 2

**SYSTEM DESIGN**

Figure 47 shows the example of system connection diagram for Serial Mode.

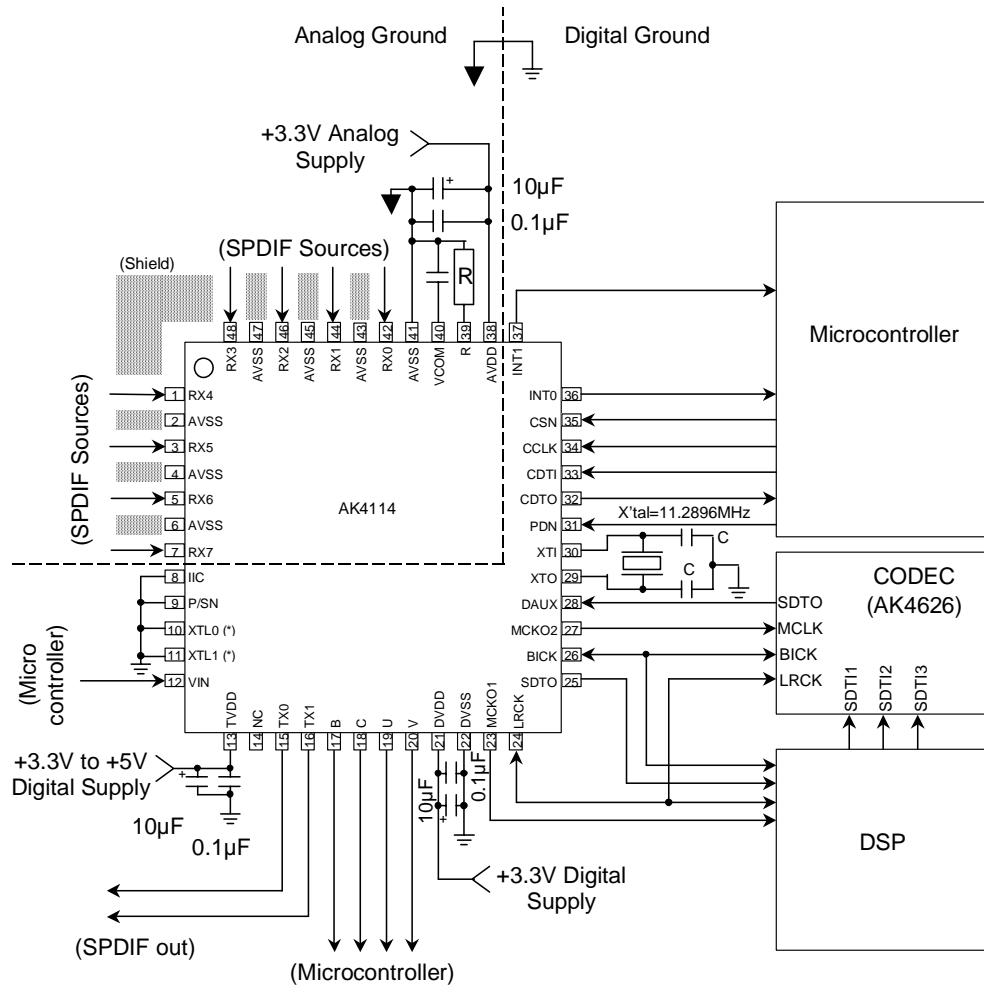

Figure 47. Typical Connection Diagram (Serial Mode)

Notes:

- For setting of XTAL0 and XTAL1, refer the Table 3.
- "C" depends on the crystal.
- AVSS and DVSS must be connected the same ground plane.
- Digital signals, especially clocks, should be kept away from the R pin in order to avoid an effect to the clock jitter performance.

PACKAGE

### 48pin LQFP(Unit:mm)

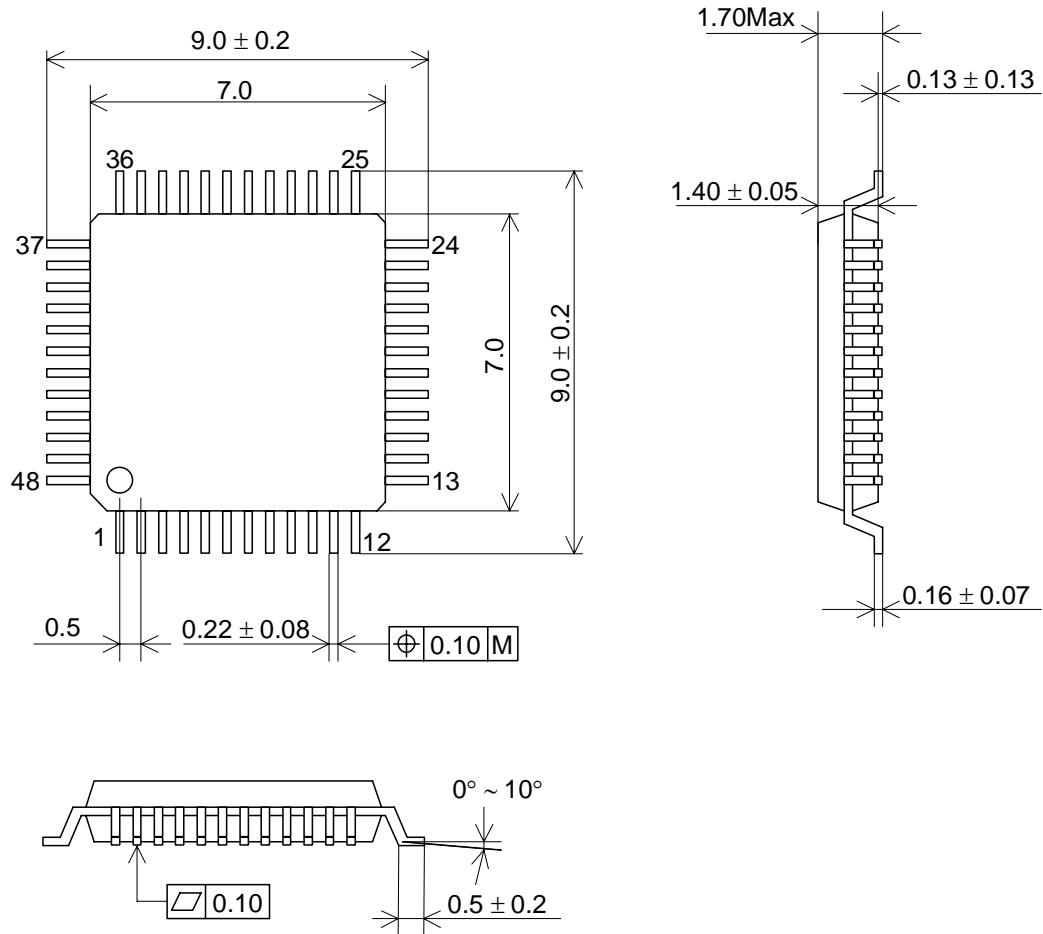

■ Material & Lead finish

- Package molding compound: Epoxy
- Lead frame material: Cu
- Lead frame surface treatment: Solder (Pb free) plate

<b>MARKING</b>
----------------

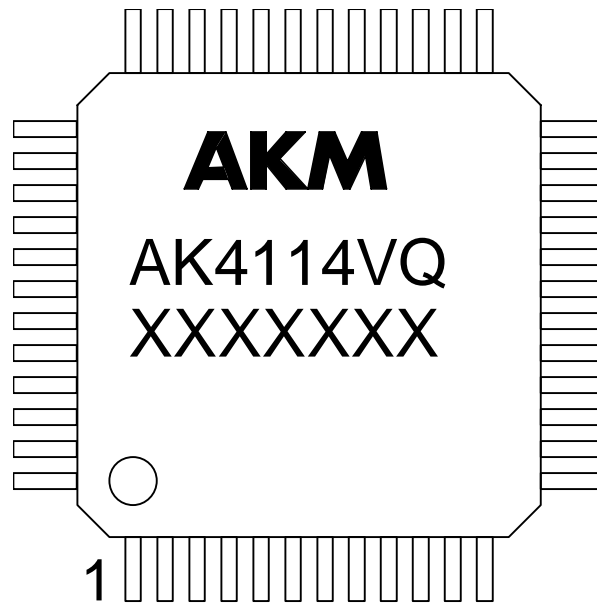

XXXXXXXX: Date code identifier

IMPORTANT NOTICE

- These products and their specifications are subject to change without notice. Before considering any use or application, consult the Asahi Kasei Microsystems Co., Ltd. (AKM) sales office or authorized distributor concerning their current status.
- AKM assumes no liability for infringement of any patent, intellectual property, or other right in the application or use of any information contained herein.
- Any export of these products, or devices or systems containing them, may require an export license or other official approval under the law and regulations of the country of export pertaining to customs and tariffs, currency exchange, or strategic materials.
- AKM products are neither intended nor authorized for use as critical components in any safety, life support, or other hazard related device or system, and AKM assumes no responsibility relating to any such use, except with the express written consent of the Representative Director of AKM. As used here:
  - (a) A hazard related device or system is one designed or intended for life support or maintenance of safety or for applications in medicine, aerospace, nuclear energy, or other fields, in which its failure to function or perform may reasonably be expected to result in loss of life or in significant injury or damage to person or property.
  - (b) A critical component is one whose failure to function or perform may reasonably be expected to result, whether directly or indirectly, in the loss of the safety or effectiveness of the device or system containing it, and which must therefore meet very high standards of performance and reliability.
- It is the responsibility of the buyer or distributor of an AKM product who distributes, disposes of, or otherwise places the product with a third party to notify that party in advance of the above content and conditions, and the buyer or distributor agrees to assume any and all responsibility and liability for and hold AKM harmless from any and all claims arising from the use of said product in the absence of such notification.