



AK4252

Output Coupling Capacitor-less Video Amp with LPF

GENERAL DESCRIPTION

The AK4252 is a Video Amp with LPF. The output coupling capacitor can be removed because the AK4252 includes the negative power supply circuit. The AK4252 is housed in a space-saving 8-pin USON package.

FEATURE

1. Video Function
 - A Composite Video Input
 - A Video-Amp (+12dB) for Composite Video Signal
 - Low Pass Filter
 - Charge pump circuit for negative power supply
2. Ta = -40 ~ 85 °C
3. Power Supply: 2.7 ~ 3.6V (typ. 3.0V)
4. Power Supply Current: 10 mA
5. Package: 8 pin USON

■ Block Diagram

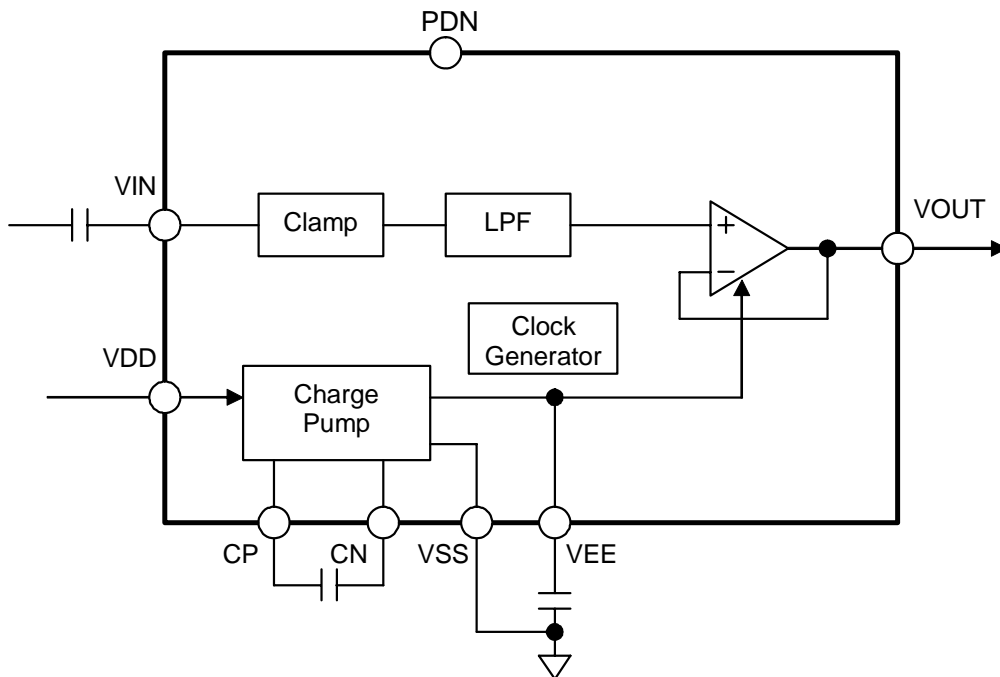
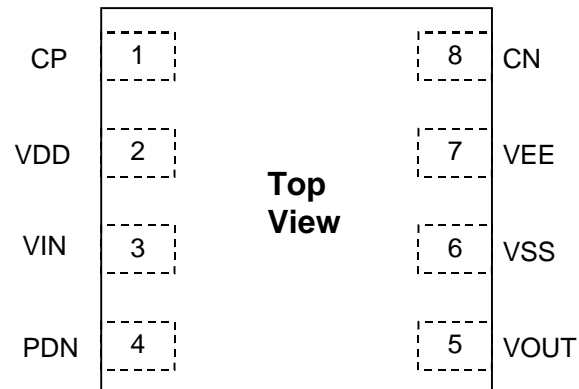

Figure 1. AK4252 Block Diagram

■ Ordering GuideAK4252VU
AKD4252-40 ~ +85°C
Evaluation board for AK4252

8 pin USON (0.5mm pitch)

■ Pin Layout

PIN/FUNCTION

No.	Pin Name	I/O	Function
1	CP	O	Positive Charge Pump Capacitor Terminal Pin
2	VDD	-	Power Supply Pin.
3	VIN	I	Composite Video Signal Input Pin
4	PDN	I	Power-Down Mode Pin. Internal Pull Down 100kΩ. “H”: Power up, “L”: Power down.
5	VOUT	O	Composite Video Signal Driver Pin
6	VSS	-	Ground Pin
7	VEE	O	Negative Voltage Output Pin for Video Amplifier
8	CN	I	Negative Charge Pump Capacitor Terminal Pin

ABSOLUTE MAXIMUM RATINGS

(VSS=0V; Note 1)

Parameter	Symbol	min	max	Units
Power Supplies	VDD	-0.3	4.0	V
Input Current, Any Pin Except Supplies	IIN	-	±10	mA
Input Voltage (Note 2)	VIN	-0.3	(VDD+0.3) or 4.0	V
Ambient Temperature (powered applied)	Ta	-40	85	°C
Storage Temperature	Tstg	-65	150	°C

Note 1. All voltages are with respect to ground.

Note 2. VIN, PDIN pins. Max value is smaller value between (VDD+0.3)V and 4.0V. The VOUT pin becomes Hi-Z at the PDN pin = “L”. Therefore the VOUT pin is available to signal line from another device by Wired-OR. The input signal to the VOUT pin must not exceed this input voltage range. Any voltage must not be applied to the CN pin.

WARNING: Operation at or beyond these limits may result in permanent damage to the device.
Normal operation is not guaranteed at these extremes.

RECOMMENDED OPERATING CONDITIONS

(VSS=0V; Note 1)

Parameter	Symbol	min	typ	max	Units
Power Supplies	VDD	2.7	3.0	3.6	V

Note 1. All voltages with respect to ground.

* AKM assumes no responsibility for the usage beyond the conditions in this datasheet.

ANALOG CHARACTERISTICS

(Ta=25°C; VDD=3.0V; VSS = 0V; unless otherwise specified)

Parameter	Conditions	min	typ	max	Units
V Input Characteristics					
Input Voltage		-	-	0.75	Vpp
Input Sync Chip Clamp Voltage	(Note 3)	-0.193	-0.143	-0.093	V
V Output Characteristics (Note 4)					
Output Gain	VIN=100kHz, 0.2Vpp	11.0	12.0	13.0	dB
Maximum output voltage	VIN=100kHz, THD=-30dB	2.52	-	-	Vpp
S/N	BW=100kHz ~ 6MHz, (Note 5)	-	65	-	dB
Secondary Distortion	VIN=3.58MHz, 0.2Vpp (Sin Wave)	-	-45	-	dB
Load Resistance		140	150	-	Ω
Load Capacitance	C1 (Figure 2)	-	-	15	pF
	C2 (Figure 2)	-	-	400	pF
LPF					
Frequency Response	Response at 6.75MHz	-3	-0.5	-	dB
Input= 0.2Vpp, Sin Wave (0dB at 100kHz)	Response at 27MHz	-	-40	-20	dB
Group Delay	GD3MHz - GD6MHz	-	10	100	nsec
Power Supplies					
Power Up	Black signal is output and no load resistance.	-	10	15	mA
Power Down	PDN pin = 0V	-	1	2	μA

Note 3. The Charge Pump circuit will not work well, if the sync chip clamp voltage input to the VIN pin is not within this voltage range. This sync chip clamp voltage is the voltage from the pedestal voltage

Note 4. The measurement point is the point A in Figure 2

Note 5. The reference signal is the 100% white signal.

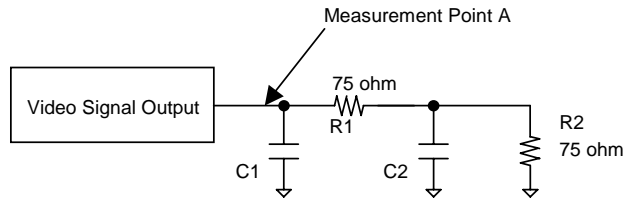

Figure 2. Load Capacitance C1 and C2

DC CHARACTERISTICS

(Ta=25°C; VDD=2.7 ~ 3.6V)

Parameter		Symbol	min	typ	max	Units
High-Level Input Voltage	(PDN pin)	VIH	1.5	-	-	V
Low-Level Input Voltage	(PDN pin)	VIL	-	-	0.6	V

■ Video Block

The Video Amp has drivability for a load resistance of 150Ω. The AK4252 has a composite input and output and includes a low pass filter (LPF). Internal negative power supply circuit supplies negative voltage to the video amp and video amp 0V output is used for a pedestal level. Therefore, the output coupling capacitor can be removed.

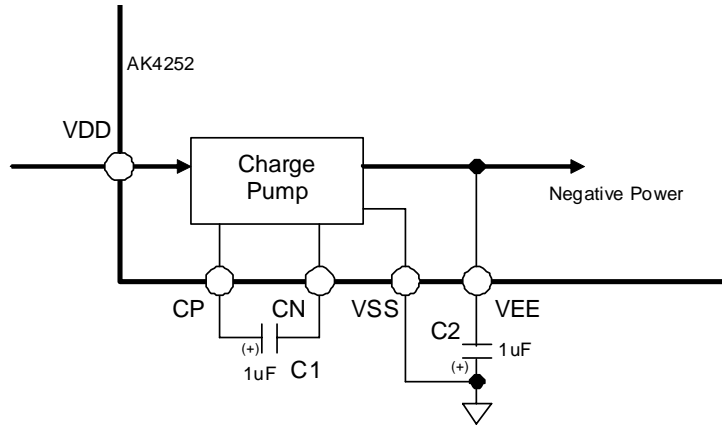

Note 6. C1 and C2 capacitors should have the low ESR (Equivalent Series Resistance) over all temperature range. When these capacitors have the polarity, the positive polarity pin should be connected to the CP pin and the VSS pin. Non polarity capacitors can also be used.

Figure 3. Negative Power Supply circuit

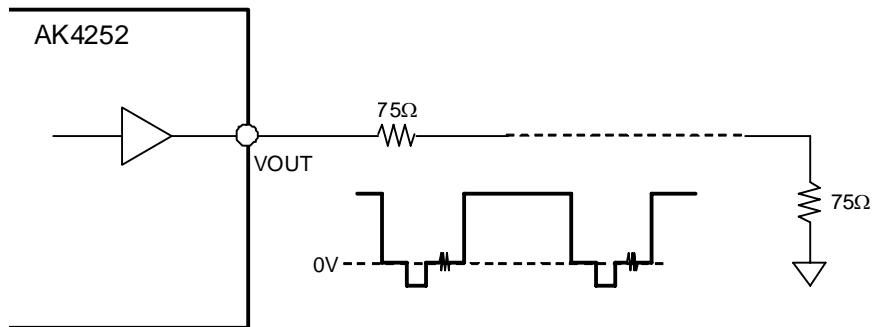

Figure 4. Video signal output

■ Power Down Control

When the PDN pin is “L”, the AK4252 is forced to Power Down Mode (Power consumption: typ 1μA). The VOUT pin becomes Hi-Z at the PDN pin = “L”. The AK4252 includes a power-on-reset function. Therefore any external reset is not required.

SYSTEM DESIGN

Figure 5 shows the system connection diagram for the AK4252. An evaluation board [AKD4252] is available which demonstrates the optimum layout, power supply arrangements and measurement results.

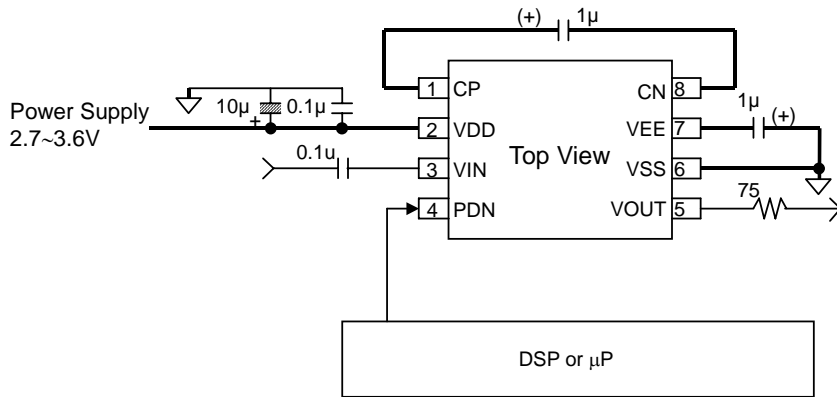

Figure 5. Typical Connection Diagram

Note:

- Any voltage must not be applied to the CN pin.

PACKAGE

8pin USON (Unit: mm)

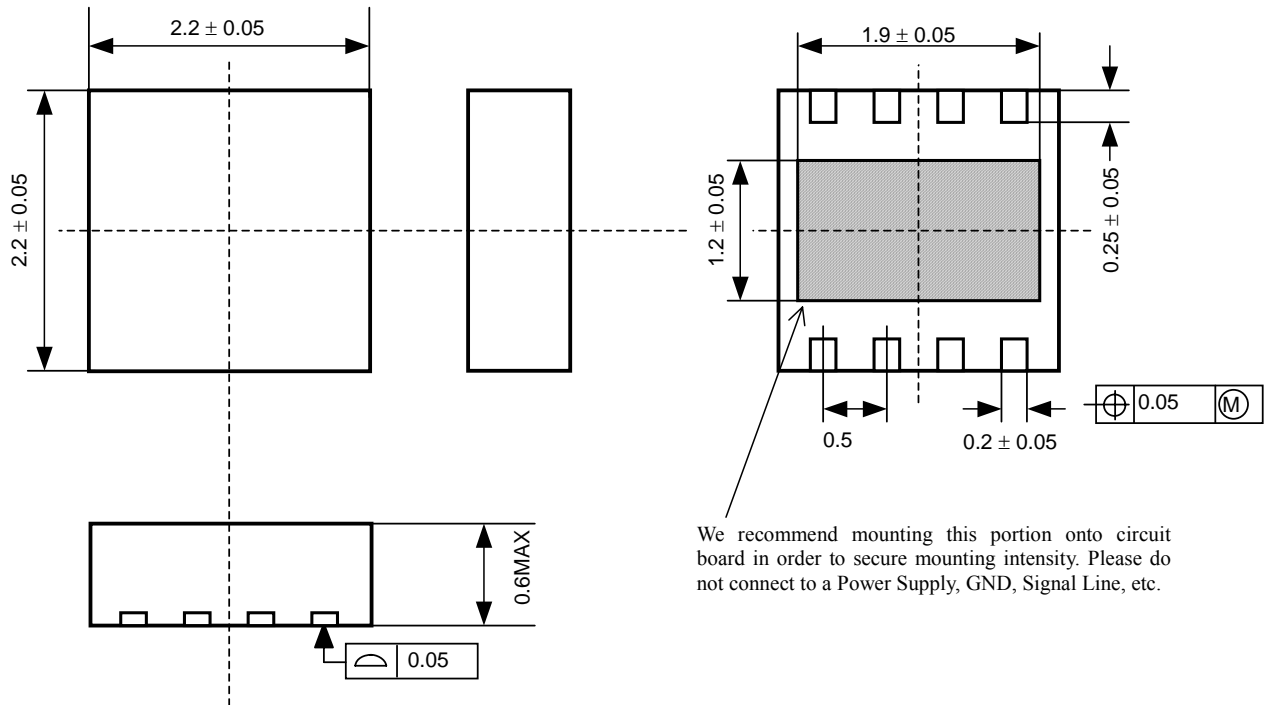

■ Material & Lead finish

Package molding compound:	Epoxy, Halogen (bromine and chlorine) free
Lead frame material:	Ni
Lead frame surface treatment:	Au plate

MARKING

■ **AK4252VU**

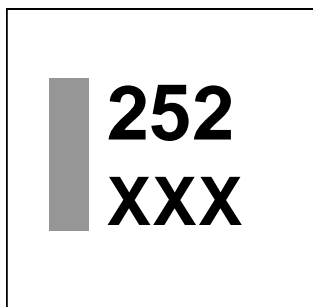

1

XXX: Date code (3 digit)

REVISION HISTORY

Date (YY/MM/DD)	Revision	Reason	Page	Contents
09/06/10	00	First Edition		
10/04/08	03	Error Correct	7	<ul style="list-style-type: none"> ■ Material & Lead finish <li style="padding-left: 20px;">Lead frame surface treatment: Ag plate → Au plate

IMPORTANT NOTICE

- These products and their specifications are subject to change without notice.
When you consider any use or application of these products, please make inquiries the sales office of Asahi Kasei Microdevices Corporation (AKM) or authorized distributors as to current status of the products.
- AKM assumes no liability for infringement of any patent, intellectual property, or other rights in the application or use of any information contained herein.
- Any export of these products, or devices or systems containing them, may require an export license or other official approval under the law and regulations of the country of export pertaining to customs and tariffs, currency exchange, or strategic materials.
- AKM products are neither intended nor authorized for use as critical components_{Note1}) in any safety, life support, or other hazard related device or system_{Note2}), and AKM assumes no responsibility for such use, except for the use approved with the express written consent by Representative Director of AKM. As used here:
 - Note1) A critical component is one whose failure to function or perform may reasonably be expected to result, whether directly or indirectly, in the loss of the safety or effectiveness of the device or system containing it, and which must therefore meet very high standards of performance and reliability.
 - Note2) A hazard related device or system is one designed or intended for life support or maintenance of safety or for applications in medicine, aerospace, nuclear energy, or other fields, in which its failure to function or perform may reasonably be expected to result in loss of life or in significant injury or damage to person or property.
- It is the responsibility of the buyer or distributor of AKM products, who distributes, disposes of, or otherwise places the product with a third party, to notify such third party in advance of the above content and conditions, and the buyer or distributor agrees to assume any and all responsibility and liability for and hold AKM harmless from any and all claims arising from the use of said product in the absence of such notification.