



AK4145

Digital BTSC Stereo Encoder

GENERAL DESCRIPTION

The AK4145 is a BTSC Encoder with D/A Converter, which is optimized for Digital AV application. The AK4145 achieves high audio performance using a digital BTSC encoding architecture which requires no alignment of external parts. The AK4145 supports major audio data formats (MSB justified, I²S, TDM) to interface with usual DSP. Therefore, the AK4145 is suitable for the systems such as Digital STB/TV, digital recorder.

FEATURES

- Alignment Free Digital BTSC Stereo Encoding
- Base band Composite Audio Output (Mono/Stereo)
- Digital Volume for Composite Audio Output
- Digital De-emphasis filter (32k/44.1k/48kHz)
- Stereo Digital Volume Control for Audio Input Data
- Soft Mute
- Stereo Matrix Control
- Sampling Rate (fs): 32k/44.1k/48kHz
- Master Clock: 256fs/384fs/512fs/768fs
- I/F format: 24-Bit MSB justified, 24/20/16-Bit LSB justified or I²S
- Control: Standalone/I²C-bus Selectable
- Video Input for Pilot Synchronization
- S/(N+D): 0.01%
- S/N: 82dB
- Channel Separation: 47dB
- Power Supply: 1.7V ~ 1.9V, 2.7 ~ 3.6V
- Ta: -20 ~ 85°C

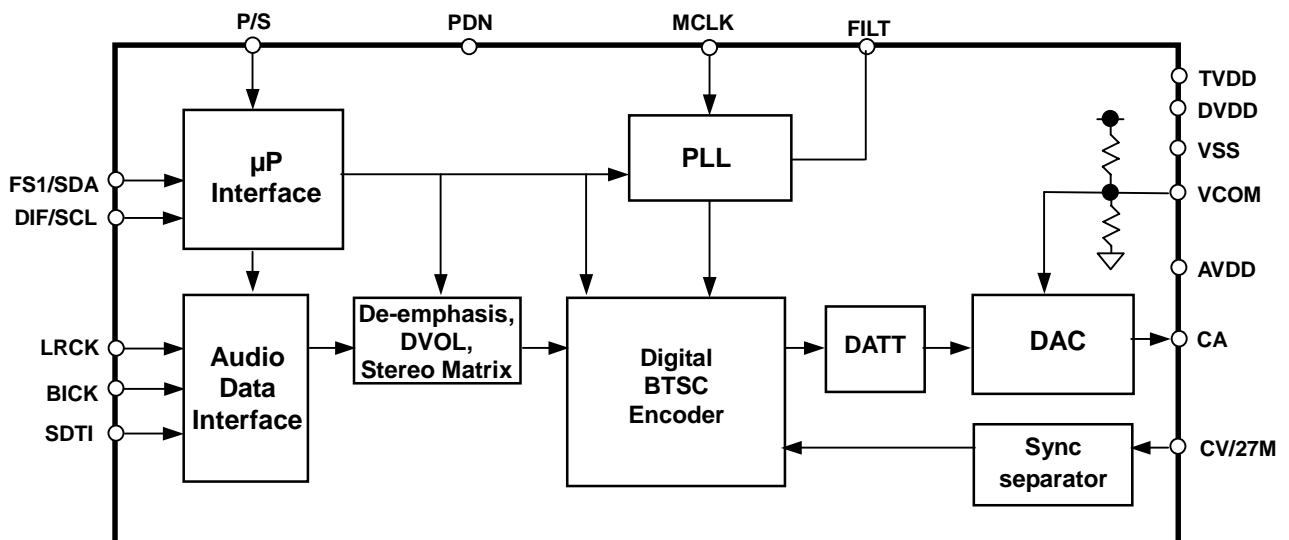

■ Ordering Guide

AK4145ET
AKD4145-20 ~ +85°C
Evaluation Board

16pinTSSOP

■ Pin Layout

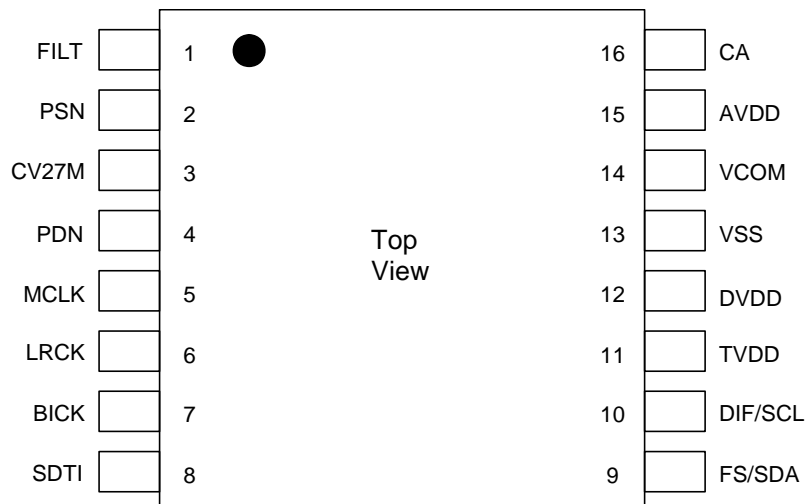

PIN/FUNCTION			
No.	Pin Name	I/O	Function
1	FILT	-	Filter Pin, 4.7nF must be connected between FILT pin and VSS pin.
2	PSN	I	Parallel/Serial Select Pin “L”: Serial control mode, “H”: Parallel control mode
3	CV27M	I	Composite Video or 27MHz Signal Input Pin.
4	PDN	I	Power-Down Mode Pin When at “L”, the AK4145 is in the power-down mode and is held in reset. The AK4145 must be reset once upon power-up.
5	MCLK	I	Master Clock Input Pin
6	LRCK	I	Channel Clock Input Pin
7	BICK	I	Audio Serial Data Clock Input Pin
8	SDTI	I	Audio Serial Data Input Pin
9	FS	I	Sampling Rate Control Pin in parallel control mode
	SDA	I/O	Control Data Pin in serial control mode
10	DIF	I	Audio Data Interface Format Pin in parallel control mode
	SCL	I	Control Data Clock Pin in serial control mode
11	TVDD	-	Digital I/O Power Supply Pin, DVDD(min:1.7V) ~ 3.6V
12	DVDD	-	Digital Power Supply Pin, 1.7 ~ 1.9V
13	VSS	-	Ground Pin
14	VCOM	O	Common Voltage Pin, AVDD/2 Normally connected to VSS with a 0.1μF ceramic capacitor in parallel with a 10μF electrolytic cap.
15	AVDD	-	Analog Power Supply Pin, 2.7 ~ 3.6V
16	CA	O	Baseband Composite Audio Output Pin

Note: All input pins should not be left floating.

■ Handling of Unused Pin

The unused I/O pins should be processed appropriately as below.

Classification	Pin Name	Setting
Analog	CV	Connect to VSS.
Digital	FS(Parallel mode), DIF(Parallel mode)	Connect to VDD or VSS.

■ Output Status at PDN pin = “L”

Below is the output status of each output pin when the PDN pin = “L”.

Pin#	Pin Name	Status
1	FILT	VSS
9	SDA	Hi-Z
14	VCOM	VSS
16	CA	VCOM(=VSS)

ABSOLUTE MAXIMUM RATINGS

(VSS=0V; Note 1)

Parameter	Symbol	min	max	Units
Power Supply	AVDD	-0.3	4.3	V
	DVDD	-0.3	2.4	V
	TVDD	-0.3	4.3	V
Input Current, Any Pin Except Supply	IIN	-	±10	mA
Analog Input Voltage (CV27M pin)	VINA	-0.3	AVDD+0.3	V
Digital Input Voltage (Note 2)	VIND	-0.3	TVDD+0.3	V
Ambient Temperature (powered applied)	Ta	-20	85	°C
Storage Temperature	Tstg	-65	150	°C

Note 1. All voltages with respect to ground.

Note 2. PSN, PDN, MCLK, LRCK, BICK, SDTI, FS/SDA, DIF/SCL pin

WARNING: Operation at or beyond these limits may result in permanent damage to the device.
Normal operation is not guaranteed at these extremes.

RECOMMENDED OPERATING CONDITIONS

(VSS=0V; Note 1)

Parameter	Symbol	min	typ	max	Units
Power Supply	AVDD	2.7	3.3	3.6	V
	DVDD	1.7	1.8	1.9	V
	TVDD	DVDD	3.3	3.6	V

WARNING: AKM assumes no responsibility for the usage beyond the conditions in this datasheet.

ANALOG CHARACTERISTICS

(Ta=25°C; AVDD=TVDD=3.3V; DVDD=1.8V; fs=48kHz; BICK=64fs; Signal Frequency=1kHz; 16bit Data; Measurement frequency=50Hz ~ 13kHz; unless otherwise specified)

Parameter	min	typ	max	Units	
Resolution			16	Bits	
Composite Audio Output Characteristics					
Output Voltage		2.2		Vp-p	
Load Resistance	5			kΩ	
Load Capacitance			25	pF	
BTSC Encoder Characteristics (Note 4)					
S/(N+D)	Mono (1kHz, 100%EIM)		0.01	0.3	%
	Stereo (1kHz, 100%EIM. L or R)		0.01	0.3	%
S/N (A-weighted)	Mono (input off)	75	82		dB
	Stereo (input off)	75	82		dB
Stereo Separation	1kHz		47		dB
	20Hz~500Hz	30			dB
	500Hz~5kHz	27			dB
	5kHz~13kHz	23			dB
Frequency response	Mono (20~13kHz)	-1		1	dB
	Stereo (20~13kHz)	-1		1	dB
Video Sync Input Characteristics					
Video Input Sync Level	100			mVp-p	
Video Input Current		2		uA	
Power Supplies					
Power Supply Current					
Normal Operation (PDN pin = "H"):					
AVDD		14		mA	
DVDD		9		mA	
TVDD		1		mA	
AVDD+DVDD+TVDD			30	mA	
Power down mode (PDN pin = "L"): (Note 5)					
AVDD		10	100	μA	
DVDD		10	100	μA	
TVDD		10	100	μA	

Note 3. AC-load.

Note 4. Received by the Belar TVM230 (BTSC Decoder) and measured by the Audio Precision (System Two). Refer to the evaluation board manual.

Note 5. All digital input pins are held to VSS.

DC CHARACTERISTICS

(Ta=-20~ 85°C; AVDD=TVDD=1.7~3.6V, DVDD=1.7~1.9V)

Parameter	Symbol	min	typ	Max	Units
High-Level Input Voltage					
TVDD < 2.7V	VIH	80%TVDD	-	-	V
TVDD ≥ 2.7V(PSN pin)	VIH	80%TVDD	-	-	V
TVDD ≥ 2.7V(except PSN pin)	VIH	70%TVDD	-	-	V
Low-Level Input Voltage					
TVDD < 2.7V	VIL	-	-	20%TVDD	V
TVDD ≥ 2.7V(PSN pin)	VIL	-	-	20%TVDD	V
TVDD ≥ 2.7V(except PSN pin)	VIL	-	-	30%TVDD	V
Low-Level Output Voltage (SDA pin: Iout= 3mA)	VOL	-	-	0.3	V
Input Leakage Current	Iin	-	-	± 10	μA

SWITCHING CHARACTERISTICS

(Ta=-20~ 85°C; AVDD=2.7 ~ 3.6V, TVDD=1.7~3.6V, DVDD=1.7~1.9V)

Parameter	Symbol	min	typ	max	Units
Master Clock Frequency	fCLK	8.192		36.8640	MHz
Duty Cycle	dCLK	40		60	%
LRCK Frequency	fs	32		48	kHz
Duty Cycle	Duty	45		55	%
Audio Interface Timing					
BICK Period	tBCK	1/128fs			ns
BICK Pulse Width Low	tBCKL	30			ns
Pulse Width High	tBCKH	30			ns
BICK rising to LRCK Edge	tBLR	20			ns
LRCK Edge to BICK rising	tLRB	20			ns
SDTI Hold Time	tSDH	20			ns
SDTI Setup Time	tSDS	20			ns
Control Interface Timing (I ² C Bus)					
SCL Clock Frequency	fSCL	-		400	kHz
Bus Free Time Between Transmissions	tBUF	1.3		-	μs
Start Condition Hold Time (prior to first clock pulse)	tHD:STA	0.6		-	μs
Clock Low Time	tLOW	1.3		-	μs
Clock High Time	tHIGH	0.6		-	μs
Setup Time for Repeated Start Condition	tSU:STA	0.6		-	μs
SDA Hold Time from SCL Falling	tHD:DAT	0		-	μs
SDA Setup Time from SCL Rising	tSU:DAT	0.1		-	μs
Rise Time of Both SDA and SCL Lines	tR	-		0.3	μs
Fall Time of Both SDA and SCL Lines	tF	-		0.3	μs
Setup Time for Stop Condition	tSU:STO	0.6		-	μs
Pulse Width of Spike Noise Suppressed by Input Filter	tSP	-		50	ns
Capacitive load on bus	Cb	0		400	pF
Reset Timing					
PDN Pulse Width	tPD	150			ns

Note 6. BICK rising edge must not occur at the same time as LRCK edge.

Note 7. Data must be held for sufficient time to bridge the 300 ns transition time of SCL.

Note 8. The AK4145 can be reset by bringing the PDN pin = "L".

Note 9. I²C-bus is a trademark of NXP B.V.

■ Timing Diagram

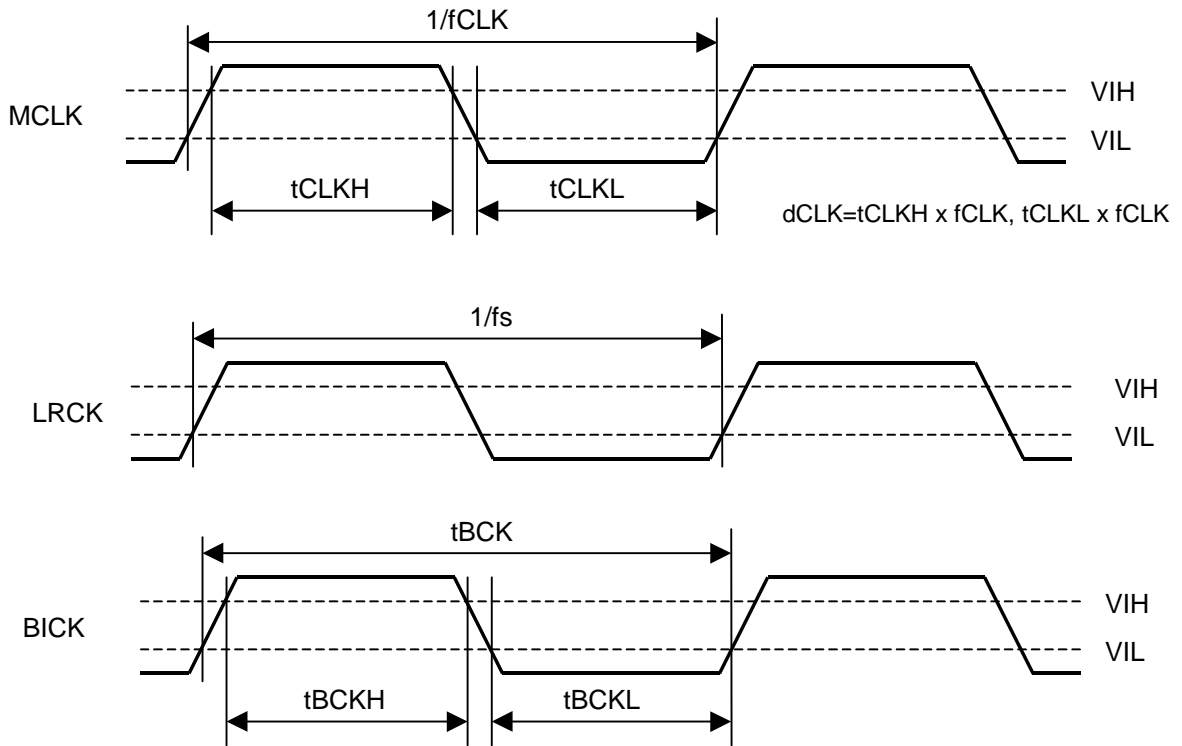

Figure 1. Clock Timing

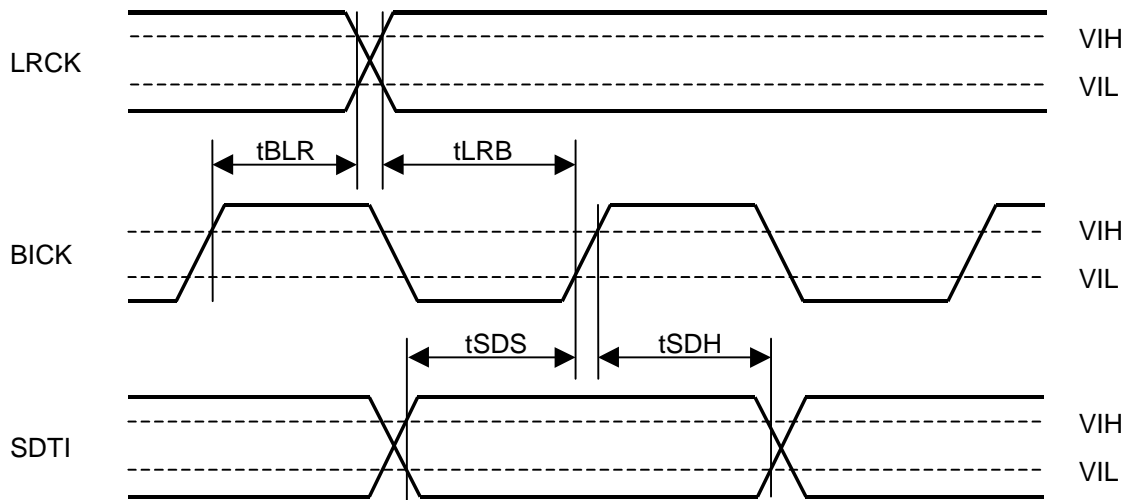

Figure 2. Serial Interface Timing

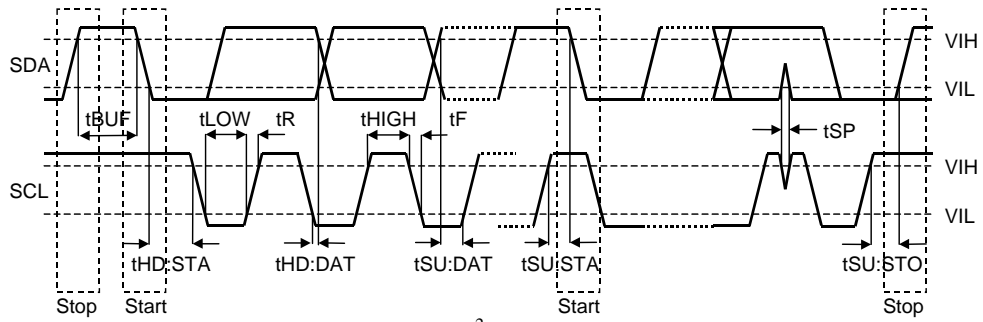

Figure 3. I²C Bus mode Timing

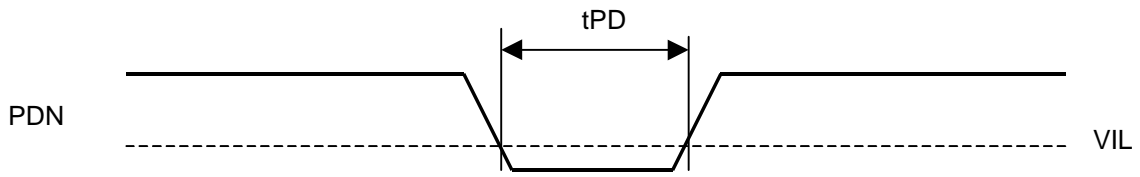

Figure 4. Power-down Timing

OPERATION OVERVIEW

■ Parallel/Serial Control Mode

Pins (Parallel Control Mode) or registers (Serial Control Mode) control each function of the AK4145 (Table 1). In Parallel Control Mode (PSN pin = “H”), register settings are ignored, and pin settings are ignored in Serial Control Mode (PSN pin = “L”). In Serial Control Mode, the default state is in software reset and soft-muted. Write “1” to RSTN bit and “0” to SMUTE bit for normal operation. The PSN pin must be fixed during power-up.

Function	Parallel mode	Serial mode
Sampling Rate	32k, 48k	32k, 44.1k, 48k
Audio Data Format	I2S, MSB justified	I2S, MSB justified, LSB justified
Stereo Volume Control	-	X
De-emphasis Filter	-	X
Soft Mute	-	X
MONO Mode	-	X
Audio Composite Volume Control	-	X
Sync Source for Pilot Generation	Video Signal	Video Signal, 27MHz Clock
Stereo Matrix Control	-	X

Table 1. Function List (X: Available, -: Not available)

■ System Reset and Power-down Mode

The AK4145 should be reset once by bringing the PDN pin = “L” upon power-up.

PDN pin: Power down pin

“H”: Normal operation

“L”: Device power down. All registers are initialized.

■ Audio Sampling Rate

The AK4145 supports 3 sampling rates (32kHz, 44.1kHz and 48kHz). The FS1-0 bits select the sampling rate in serial control mode. The FS1 pin is only available in parallel control mode (Table 2, Table 3). These bits and pin can be changed without a reset by the PDN pin.

FS1 bit	FS0 bit	Sampling rate
0	0	32kHz
0	1	44.1kHz
1	0	48kHz
1	1	(Reserved)

(default)

Table 2. Sampling rate select in serial control mode

FS1 pin	Sampling rate
0	32kHz
1	48kHz

Table 3. Sampling rate select in parallel control mode

■ Power-on Sequence

After setting the PDN pin “L” to “H”, the AK4145 remains in power-down mode until a LRCK rising edge after MCLK. When the MCLK and LRCK are provided, the AK4145 exits reset state, power-on the voltage reference circuit, and the PLL will be locked. The output signal is masked until when the PLL locks to the MCLK (also RSTN bit = “1” is required in serial mode).

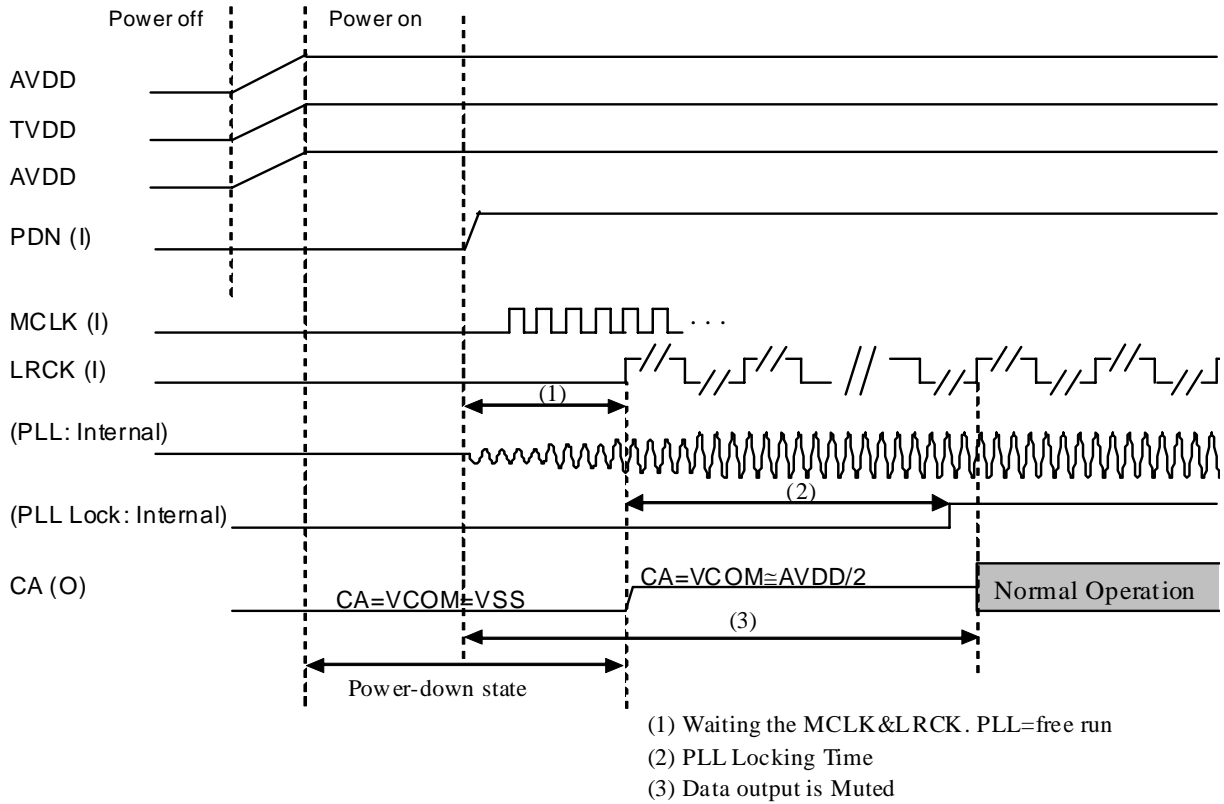

Figure 5. Power-on Sequence

Note:

When changing the sampling rate, the PLL lock signal and BTSC encoder are initialized. The output is muted until the PLL re-locks.

■ System Clock

The external clocks required to operate the AK4145 are MCLK, LRCK and BICK. The AK4145 supports 256fs, 384fs, 512fs and 768fs as master clock (MCLK). The AK4145 should be reset by the PDN pin = “L” after these clocks are provided. After exiting reset by the PDN pin = “H”, the AK4145 remains in power-down mode until a LRCK rising edge after MCLK.

fs	MCLK				BICK	
	256fs	384fs	512fs	768fs	64fs	128fs
32.0kHz	8.1920MHz	12.2880MHz	16.3840MHz	24.576MHz	2.0480MHz	4.0960MHz
44.1kHz	11.2896MHz	16.9344MHz	22.5792MHz	33.8688MHz	2.8224MHz	5.6448MHz
48.0kHz	12.2880MHz	18.4320MHz	24.5760MHz	36.8640MHz	3.0720MHz	6.1440MHz

Table 4. System clock example

■ Audio Serial Interface Format

Data is shifted in via the SDTI pin using BICK and LRCK inputs. In serial control mode (P/S pin = “L”), the DIF0-2 bits select five serial data modes as shown in Table 5. In parallel control mode (P/S pin = “H”), the DIF pin select two serial data modes as shown in Table 6. In all modes the serial data is MSB-first, 2’s compliment format and it is latched on the rising edge of BICK. Mode 2 can be used for 16/20 MSB justified formats by zeroing the unused LSBs.

Mode	DIF2 Bit	DIF1 Bit	DIF0 bit	SDTI Format	BICK	Figure
0	0	0	0	16bit LSB Justified	≥32fs	Figure 1
1	0	0	1	20bit LSB Justified	≥40fs	Figure 2
2	0	1	0	24bit MSB Justified	≥48fs	Figure 3
3	0	1	1	16/24bit I ² S Compatible	32fs or ≥48fs	Figure 4
4	1	0	0	24bit LSB Justified	≥48fs	Figure 2

(default)

Table 5. Audio Data Formats (Serial control mode)

Mode	DIF pin	SDTI Format	BICK	Figure
2	0	24bit MSB Justified	≥48fs	Figure 3
3	1	16/24bit I ² S Compatible	32fs or ≥48fs	Figure 4

Table 6. Audio Data Formats (Parallel control mode)

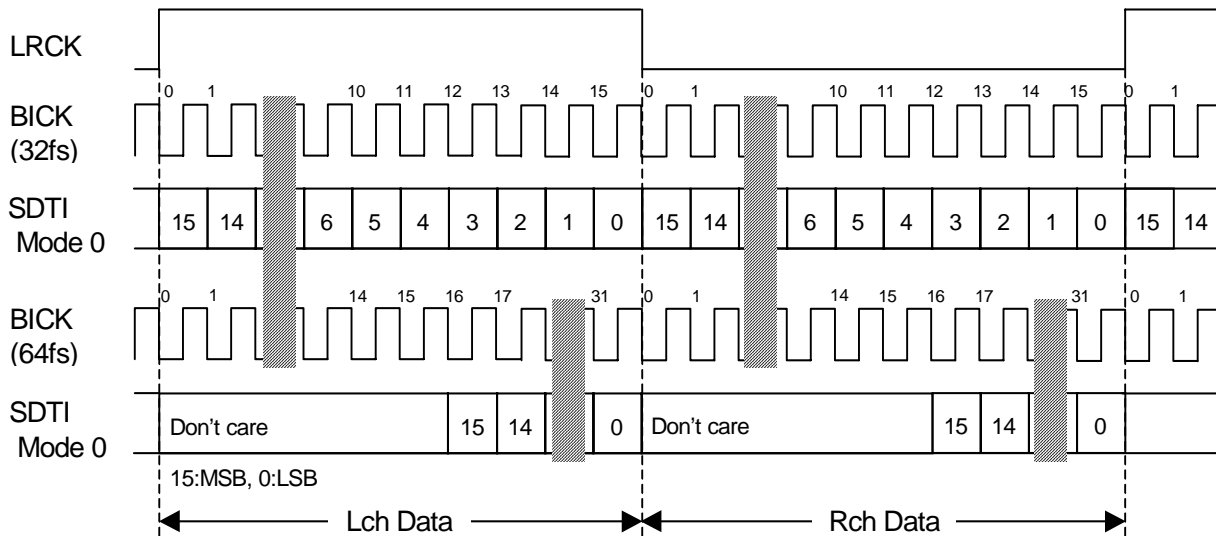

Figure 1. Mode 0 Timing

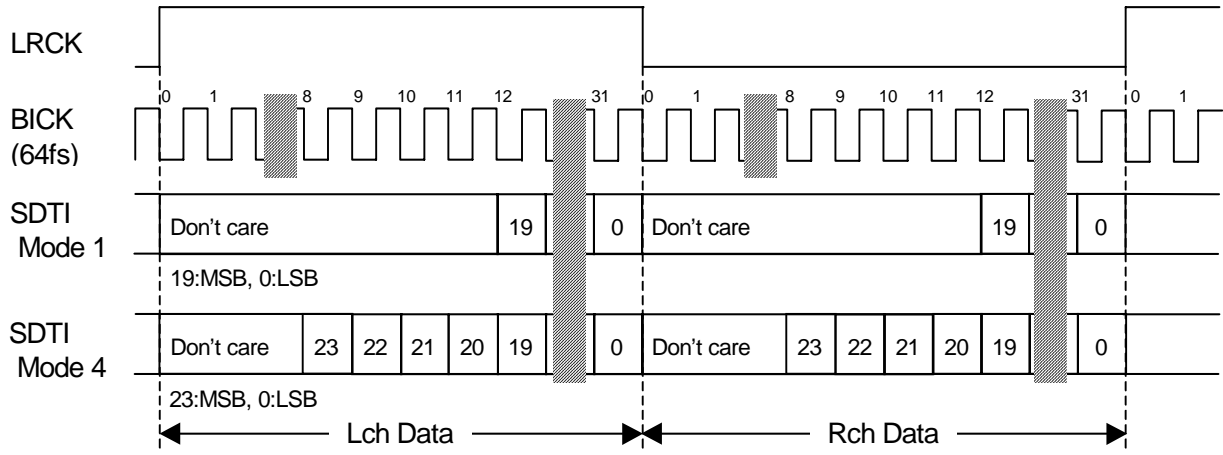

Figure 2. Mode 1/4 Timing

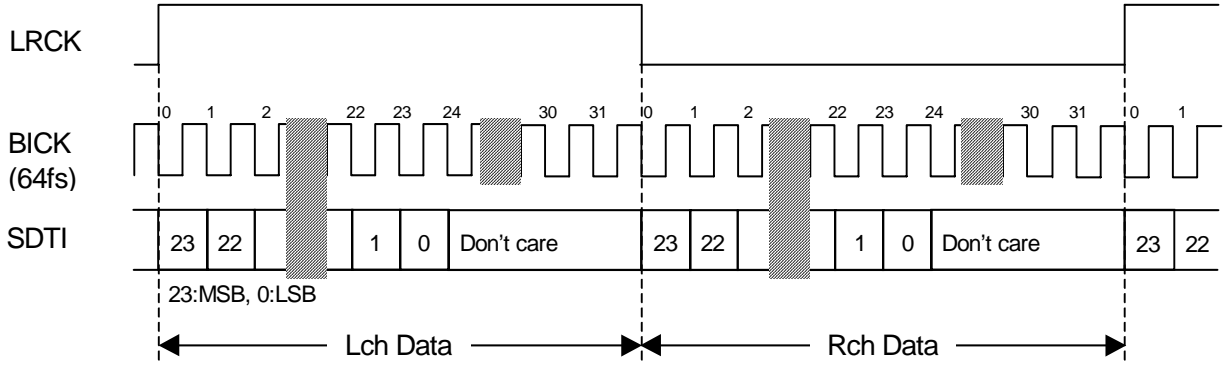

Figure 3. Mode 2 Timing

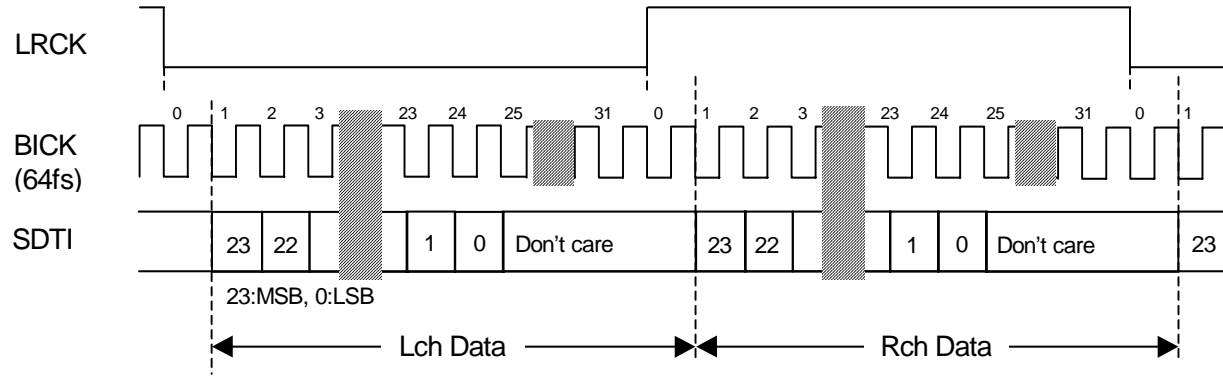

Figure 4. Mode 3 Timing

■ Input Level to BTSC Encoder

The AK4145 is designed to be 100% modulation of L+R signal when L=R= 50% (approx. -6dBFS) signal data is input. In addition to this -6dBFS, the BTSC standard contains the pre-emphasis filter. To prevent the clipping in a BTSC encoder of the AK4145, following maximum input levels are recommended. The input data can be attenuated by controlling the Stereo Volume Control registers (L7-0, R7-0 bits).

Frequency[Hz]	Maximum Input Level to BTSC Encoder[dBFS]
20~1000	-7
2500	-10
5000	-14
8000	-15
13000	-22

Table 7. Maximum Input Level to BTSC Encoder

■ Stereo Volume Control (DVOL)

The AK4145 has a stereo digital volume control (DVOL. 256 levels, 0.5dB step, Mute). The L7-0, R7-0 bits control the gain. The gain ranges from +31.0dB to -96.0dB, or MUTE. When the VOLC bit = "1" (default), the L7-0 bits control gain for both Lch and Rch. When the VOLC bit = "0", the L7-0 bits control gain for Lch and R7-0 bits control gain for Rch. This volume has a soft transition function. When changing levels, transitions are executed in soft changes; thus no switching noise occurs during these transitions. The transition time of 1 level and all levels are shown in Table 8. In parallel control mode, volume control is fixed to 0dB.

DVOL Transition Time		
1 Level	0dB to -96dB	+31.0dB to -96dB
4LRCK	768LRCK	1016LRCK

Table 8. DVOL Transition Time

L7-0	Gain
00H	+31.0dB
01H	+30.5dB
:	:
3DH	+0.5dB
3EH	0dB
3FH	-0.5dB
:	:
FDH	-95.5dB
FEH	-96.0dB
FFH	MUTE (-∞)

(default)

Table 9. Lch Digital Volume

R7-0	Gain
00H	+31.0dB
01H	+30.5dB
:	:
3DH	+0.5dB
3EH	0dB
3FH	-0.5dB
:	:
FDH	-95.5dB
FEH	-96.0dB
FFH	MUTE (-∞)

(default)

Table 10. Rch Digital Volume

■ De-emphasis Filter

A digital de-emphasis filter is built-in ($t_c = 50/15\mu s$) for pre-emphasized audio data input. Setting the DEM bit “1” enables the digital de-emphasis filter. In parallel control mode, the de-emphasis filter is always “OFF”

DEM bit	De-emphasis Filter
1	ON
0	OFF

(default)

Table 11. De-emphasis Filter Control

■ Soft Mute Operation

When the SMUTE bit is set to “1”, if the volume level was 0dB, the output signal is attenuated to $-\infty dB$ in 772 LRCK cycles. When the SMUTE bit returns to “0”, the mute is cancelled and the attenuation gradually changes to the volume level. If the soft mute is cancelled before attenuating to the mute state, the attenuation is discontinued and returned to volume level by the same cycles. The soft mute is effective for changing the signal source without stopping the signal transmission. In parallel control mode, the soft mute function is not available.

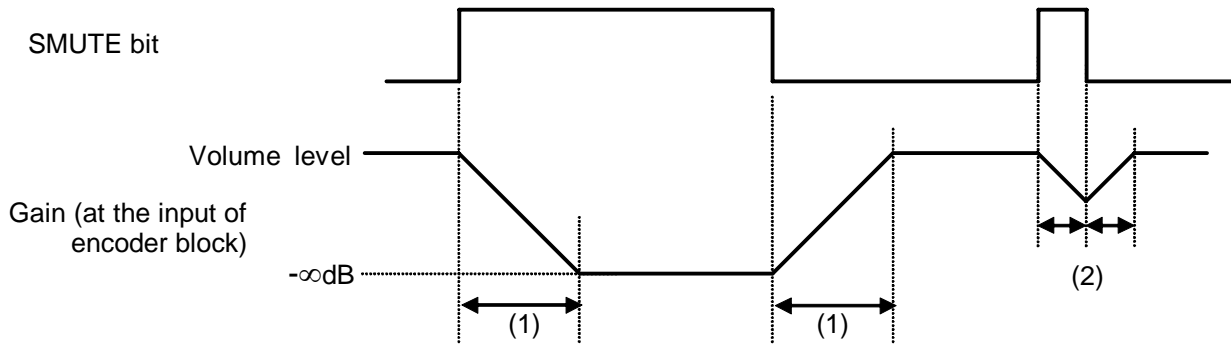

Notes:

- (1) Transition time. 772 LRCK cycles ($772/f_s$) when the volume level is 0dB.
- (2) If the soft mute is cancelled before attenuating to $-\infty$, the attenuation is discontinued and returned to the volume level by the same number of clock cycles.

Figure 6. Soft Mute

■ BTSC Stereo/MONO Output Control

The STR bit controls Stereo/MONO output mode. Setting of the STR bit “1” (default) selects BTSC stereo output mode. Setting of the STR bit “0” selects MONO mode. In parallel control mode, the AK4145 is fixed to stereo mode. The external pre-emphasis circuit must not be used.

STR bit	Composite audio output	
1	Stereo mode, outputs BTSC stereo composite	(default)
0	MONO mode, outputs only pre-emphasized (L+R) component.	

Table 12. Stereo/MONO Control

■ Audio Composite Output Volume (DATT)

The AK4145 includes a digital output volume control (DATT) for base band with 256 levels at linear step including MUTE. This volume control is in front of the DAC and can attenuate the input data from 0dB to -42dB and mute. When changing levels, transitions are executed in soft changes; thus no switching noise occurs during these transitions. The transition time of 1 level and all 256 levels is shown in Table 10. In parallel control mode, this volume is fixed to 0dB.

DATT Transition Time	
1 Level	255 to 0
4LRCK	1020LRCK

Table 10. DATT Transition Time

■ Video Sync Input

When VCLK bit = “0” (default), the sync separator generates the sync signal using external composite video signal via the CV27M pin. When VCLK bit = “1”, the 27MHz clock is required through this pin to generate the video sync signal. The sync signal is used to generate the 15.734kHz pilot tone for BTSC stereo encoding. In parallel control mode, this pin is fixed to video sync input.

■ Stereo Matrix Control

The AK4145 has the stereo matrix control. The PL3-0 bits control the matrix.

PL3	PL2	PL1	PL0	Lch Output	Rch Output	Note	
0	0	0	0	MUTE	MUTE	MUTE	
0	0	0	1	MUTE	R		
0	0	1	0	MUTE	L		
0	0	1	1	MUTE	(L+R)/2		
0	1	0	0	R	MUTE		
0	1	0	1	R	R		
0	1	1	0	R	L	REVERSE	
0	1	1	1	R	(L+R)/2		
1	0	0	0	L	MUTE		
1	0	0	1	L	R	STEREO	(default)
1	0	1	0	L	L		
1	0	1	1	L	(L+R)/2		
1	1	0	0	(L+R)/2	MUTE		
1	1	0	1	(L+R)/2	R		
1	1	1	0	(L+R)/2	L		
1	1	1	1	(L+R)/2	(L+R)/2	MONO	

Table 13. Stereo Matrix Control

■ Serial Control Interface

The AK4145 supports the fast-mode I²C-bus system (max: 400kHz).

1. Data transfer

All commands are preceded by START condition. After the START condition, a slave address is sent. When the AK4145 recognizes START condition, the device interfaced to the bus waits for the slave address to be transmitted over the SDA line. If the transmitted slave address matches an address for one of the devices, the designated slave device (receiver) pulls the SDA line to LOW (ACKNOWLEDGE). The data transfer is always terminated by STOP condition generated by the master device.

1-1. Data validity

The data on the SDA line must be stable during the HIGH period of the clock. HIGH or LOW state of the data line can only be changed when the clock signal on the SCL line is LOW except for the START and the STOP condition.

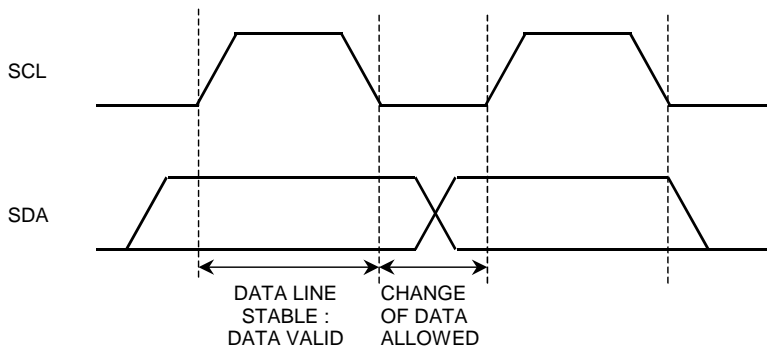

Figure 7. Data transfer

1-2. START and STOP condition

A HIGH to LOW transition on the SDA line while SCL is HIGH indicates START condition. All sequences start from the START condition. A LOW to HIGH transition on the SDA line while SCL is HIGH defines STOP condition. All sequences end by the STOP condition.

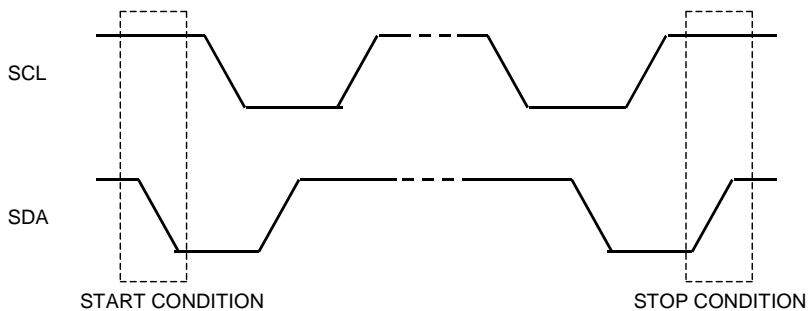

Figure 8. START and STOP conditions

1-3. ACKNOWLEDGE

ACKNOWLEDGE is a software convention used to indicate successful data transfers. The device will release the SDA line (HIGH) after transmitting the eight bits. The receiver must pull down the SDA line during the acknowledge clock pulse so that that it remains stable “L” during “H” period of this clock pulse. The AK4145 will generate an acknowledge after each byte is received.

In read mode, the slave device, the AK4145 will transmit the eight bits of data, release the SDA line and monitor the line for an acknowledge. If an acknowledge is detected, the slave device will continue transmitting the data. If an acknowledge is not detected, the slave device will terminate further data transmissions and await STOP condition.

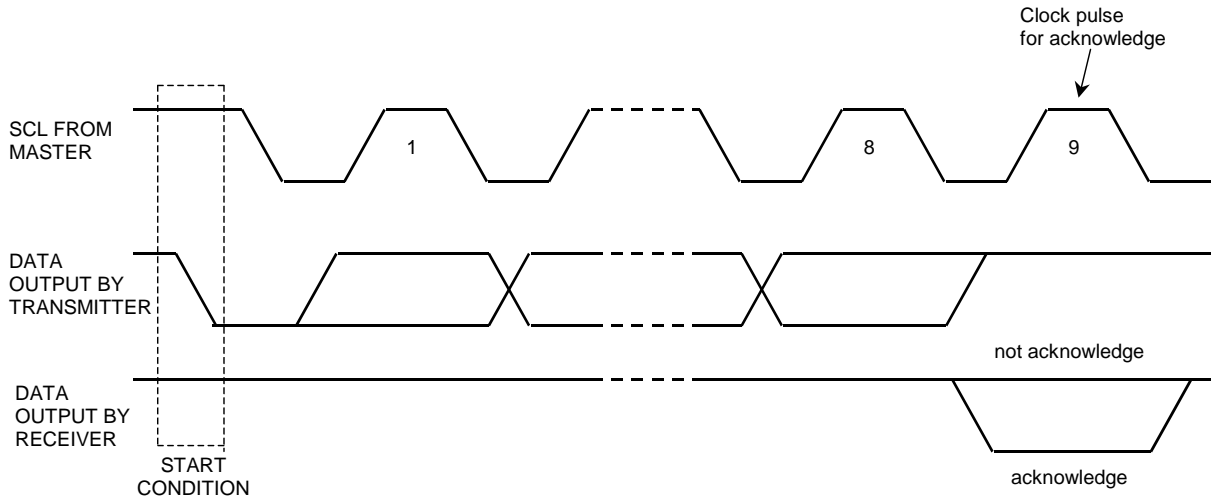

Figure 9. Acknowledge on the I²C-bus

1-4. FIRST BYTE

The first byte, which includes seven bits of slave address and one bit of R/W bit, is sent after the START condition. If the transmitted slave address matches an address for one of the device, the receiver which is addressed pulls down the SDA line.

The most significant seven bits of the slave address are fixed as “0010011”. The eighth bit (LSB) of the first byte (R/W bit) defines whether the master requested a write or read condition. A “1” indicates that the read operation is to be executed. A “0” indicates that the write operation is to be executed.

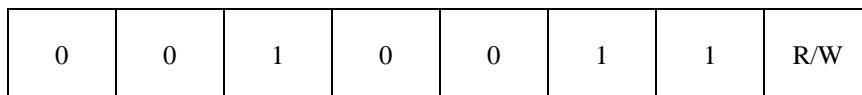

Figure 10. The First Byte

2. WRITE Operations

Set R/W bit = “0” for the WRITE operation of the AK4145.

After receipt the start condition and the first byte, the AK4145 generates an acknowledge, and awaits the second byte (register address). The second byte consists of the address for control registers of the AK4145. The format is MSB first, and those most significant 3-bits are “Don’t care”.

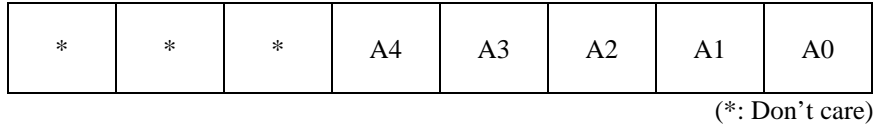

Figure 11. The Second Byte

After receipt the second byte, the AK4145 generates an acknowledge, and awaits the third byte. Those data after the second byte contain control data. The format is MSB first, 8bits.

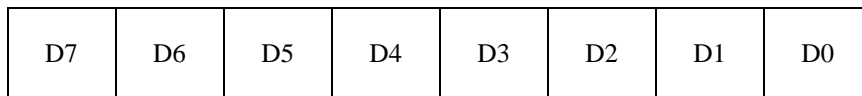

Figure 12. Byte structure after the second byte

The AK4145 is capable of more than one byte write operation in one sequence.

After receipt of the third byte, the AK4145 generates an acknowledge, and awaits the next data again. The master can transmit more than one words instead of terminating write cycle after the first data word is transferred. After the receipt of each data, the internal 5bits address counter is incremented by one, and the next data is taken into next address automatically. If the address exceeds 05H prior to generating stop condition, the address counter will “roll over” to 00H and the previous data will be overwritten.

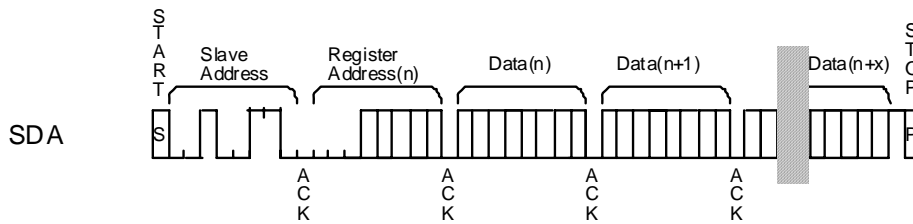

Figure 13. WRITE Operation

3. READ Operations

The AK4145 supports two basic read operations: CURRENT ADDRESS READ and RANDOM READ.

3-1. CURRENT ADDRESS READ

The AK4145 contains an internal address counter that maintains the address of the last word accessed, incremented by one. Therefore, if the last access (either a read or write) was to address “n”, the next CURRENT READ operation would access data from the address “n+1”.

After receipt of the slave address when R/W bit set to “1”, the AK4145 generates an acknowledge, transmits 1byte data which address is set by the internal address counter and increments the internal address counter by 1. The master can read next address’s data by generating an acknowledge instead of terminating the read cycle after the receipt of the data. If the address exceeds 05H prior to generating stop condition, the address counter will “roll over” to 00H and the previous data will be re-read. If the master does not generate an acknowledge but generates stop condition, the AK4145 discontinues transmission.

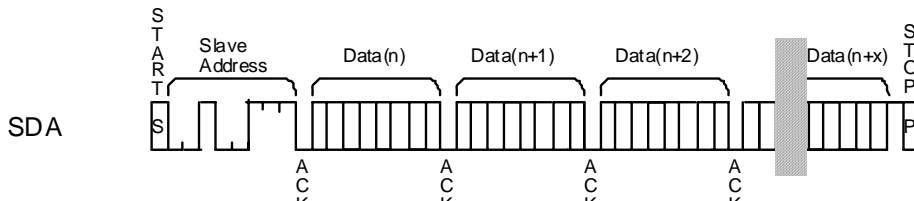

Figure 14. CURRENT ADDRESS READ

3-2. RANDOM READ

Random read operation allows the master to access any memory location at random. Prior to issuing the slave address with the R/W bit set to “1”, the master must first perform a “dummy” write operation.

The master issues start condition, slave address(R/W=“0”) and then the register address to read. After the register address’s acknowledge, the master immediately reissues start condition and the slave address with the R/W bit set to “1”. Then the AK4145 generates an acknowledge, 1byte data and increments the internal address counter by 1. The master can read next address’s data by generating the acknowledge instead of terminating read cycle after the receipt of the data. If the address exceeds 05H prior to generating the stop condition, the address counter will “roll over” to 00H and the previous data will be re-read. If the master does not generate an acknowledge but generates stop condition, the AK4145 discontinues transmission.

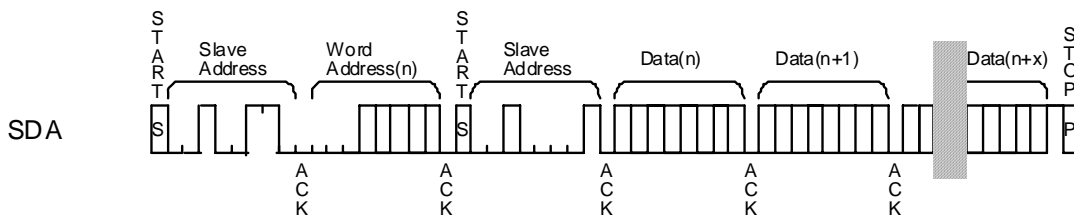

Figure 15. RANDOM READ

■ Register Map

Addr	Register Name	D7	D6	D5	D4	D3	D2	D1	D0
00H	Control 1	VCLK	DIF2	DIF1	DIF0	0	0	SMUTE	RSTN
01H	Control 2	VOLC	0	FS1	FS0	0	DEM	0	STR
02H	Lch Volume	L7	L6	L5	L4	L3	L2	L1	L0
03H	Rch Volume	R7	R6	R5	R4	R3	R2	R1	R0
04H	Composite Volume	ATT7	ATT6	ATT5	ATT4	ATT3	ATT2	ATT1	ATT0
05H	Stereo Matrix	0	0	0	0	PL3	PL2	PL1	PL0

Note: For addresses from 06H to 1FH, data must not be written.

When the PDN pin is set to “L”, the registers are initialized to their default values.

When the RSTN bit is set to “0”, the internal timing is reset, but registers are not initialized to their default values.

Do not write “1” data to the register named “0”.

■ Register Definitions

Control 1

Addr	Register Name	D7	D6	D5	D4	D3	D2	D1	D0
00H	Control 1	VCLK	DIF2	DIF1	DIF0	0	0	SMUTE	RSTN
	R/W	R/W	R/W	R/W	R/W	RD	RD	R/W	R/W
	Default	0	0	1	1	0	0	1	0

RSTN: Internal timing reset control

0: Reset. Initialize the device except register settings (default).

1: Normal Operation

SMUTE: Soft Mute Control

0: Soft Mute disabled (Normal Operation).

1: Soft Mute enabled (default).

DIF2-0: Audio data interface formats ([Table 5](#))

Default: "011", I²S

VCLK: Sync Source Control

0: Composite video (default).

1: 27MHz clock

Control 2

Addr	Register Name	D7	D6	D5	D4	D3	D2	D1	D0
01H	Control 2	VOLC	0	FS1	FS0	0	DEM	0	STR
	R/W	R/W	RD	R/W	R/W	RD	R/W	RD	R/W
	Default	1	0	1	0	0	0	0	1

STR: BTSC Stereo/MONO Output Control

0: MONO

1: BTSC Stereo Composite (default)

DEM: De-emphasis Response

0: Disable (default)

1: Enable

FS1-0: Sampling speed control

00: 32kHz

01: 44.1kHz

10: 48kHz (default)

11: Reserved

VOLC: Lch/Rch Volume Common Control Enable

0: Independent Control. L7-0 and R7-0 bits control Lch and Rch independently.

1: Common Control (default). L7-0 bits control both Lch and Rch. R7-0 bits are ignored.

Lch Volume control

Addr	Register Name	D7	D6	D5	D4	D3	D2	D1	D0
02H	Lch Volume	L7	L6	L5	L4	L3	L2	L1	L0
	R/W	R/W	R/W	R/W	R/W	R/W	R/W	R/W	R/W
	Default	0	0	1	1	1	1	1	0

L7-0: Lch Volume Control when VOLC bit = "0" (Table 9).

These bits control both Lch and Rch volume when VOLC bit = "1".

Rch Volume control

Addr	Register Name	D7	D6	D5	D4	D3	D2	D1	D0
03H	Rch Volume	R7	R6	R5	R4	R3	R2	R1	R0
	R/W	R/W	R/W	R/W	R/W	R/W	R/W	R/W	R/W
	Default	0	0	1	1	1	1	1	0

R7-0: Rch Volume Control when VOLC bit = "0" (Table 10).

Don't care when VOLC bit = "1".

BTSC Composite Volume control

Addr	Register Name	D7	D6	D5	D4	D3	D2	D1	D0
04H	Composite Volume	ATT7	ATT6	ATT5	ATT4	ATT3	ATT2	ATT1	ATT0
	R/W	R/W	R/W	R/W	R/W	R/W	R/W	R/W	R/W
	Default	1	1	1	1	1	1	1	1

$ATT = 20 \log_{10} ((ATT_DATA + 1) / 256)$ [dB]

FFH: 0dB (default)

....

00H: Mute

Stereo Matrix control

Addr	Register Name	D7	D6	D5	D4	D3	D2	D1	D0
05H	Stereo Matrix	0	0	0	0	PL3	PL2	PL1	PL0
	R/W	RD	RD	RD	RD	R/W	R/W	R/W	R/W
	Default	0	0	0	0	1	0	0	1

PL3-0: Stereo Matrix control

Refer to Table 13.

SYSTEM DESIGN

The [Figure 16](#) shows the system connection diagram. The evaluation board (AKD4145) is available for fast evaluation as well as suggestions for peripheral circuitry.

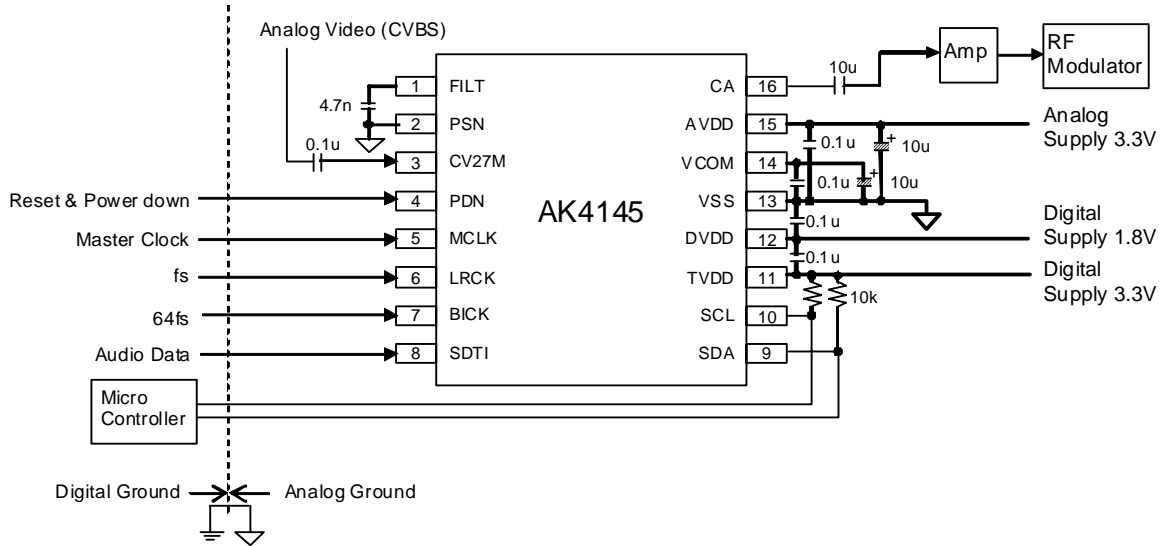

Figure 16. Typical Connection Diagram

1. Grounding and Power Supply Decoupling

The AK4145 requires careful attention to power supply and grounding arrangements. AVDD, DVDD and TVDD are usually supplied from analog supply in system. If AVDD1, AVDD2, DVDD1, DVDD2 and TVDD are supplied separately, the power up sequence is not critical. **VSS of the AK4145 must be connected to analog ground plane.** System analog ground and digital ground should be connected together near to where the supplies are brought onto the printed circuit board. Decoupling capacitors should be as near to the AK4145 as possible, with the small value ceramic capacitor being the nearest.

2. Voltage Reference Inputs

The voltage of AVDD sets the DAC analog output range. VCOM is signal ground of analog output signal. The FILT pin is Loop filter pin for internal PLL. An electrolytic capacitor 10 μ F parallel with a 0.1 μ F ceramic capacitor attached between the VCOM pin and VSS pin eliminate the effects of high frequency noise. An 4.7nF capacitor should be attached between the FILTM pin and VSS pin. No load current may be drawn from these VCOM and FILT pins. All signals, especially clocks, should be kept away from the AVDD, VCOM and FILT pins in order to avoid unwanted coupling into the AK4145.

3. Analog Video Input

In case of composite video input mode (VCLK bit = "0"), the AK4145 receives the analog video input through the CV27M pin using a 0.1 μ F ceramic capacitor in series. This video signal is used for the synchronization between the video sync and the pilot frequency on composite audio output. The video input mode is NOT available only when the TVDD is lower than 2.7V. In case of 27MHz clock input mode (VCLK bit = "1"), input the 27MHz clock directly without using a 0.1 μ F capacitor.

4. Analog Composite Audio Output

The analog output is single-ended and centered on around the VCOM voltage. The output signal range scales with the supply voltage and nominally 2.2 x AVDD/3.3 Vpp (@100kHz deviation) at the CA pin. DC offsets on analog outputs are eliminated by AC coupling. The modulation level of sound intermediate frequency (SIF) at RF modulator can be adjusted by the internal composite volume control of the AK4145 (04H D7-0: ATT7-0 bits). The stereo separation can be maximized by tuning the modulation level. If the output level of the AK4145 (typ: 2.2Vpp @100kHz deviation) is not sufficient for the RF modulator device, the external gain stage is used for the extra gain.

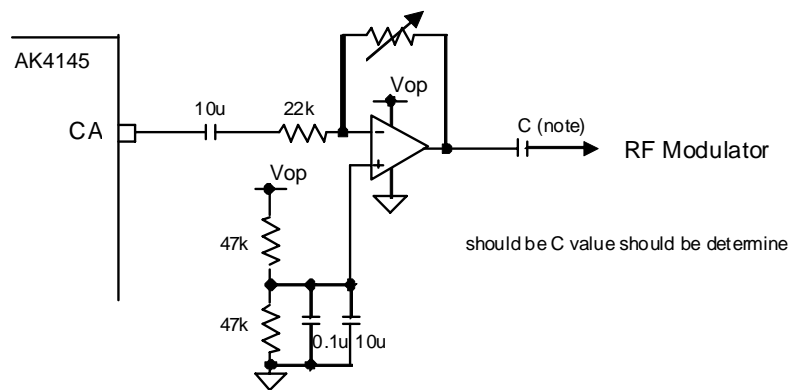

Note:

The C value must be determined taking account of the input impedance Z at RF modulator. The recommended f_c (cut-off frequency) of this high-pass filter is 1Hz or less for low frequency stereo separation. $f_c = 1/(2 \times 3.14 \times C \times Z)$.
Example: C= 10uF @Z=15kohm, C= 3.3uF @Z=50kohm.

Figure 17. External Gain Stage Example.

PACKAGE

16pin TSSOP (Unit: mm)

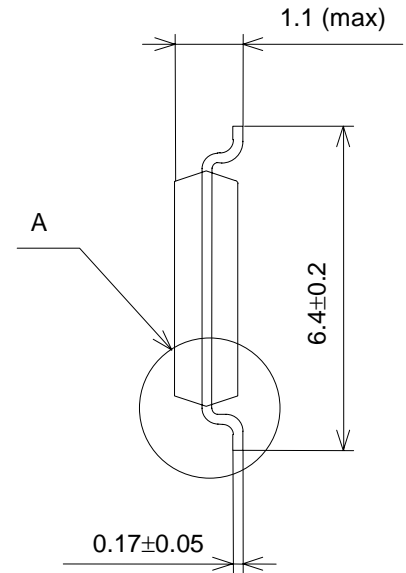
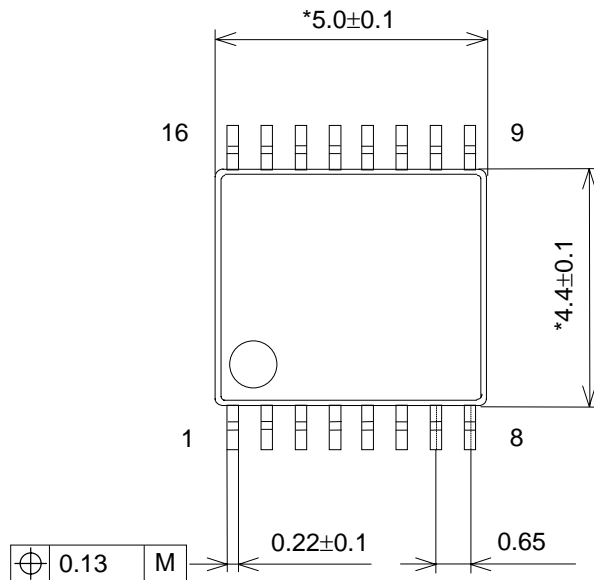

Detail A

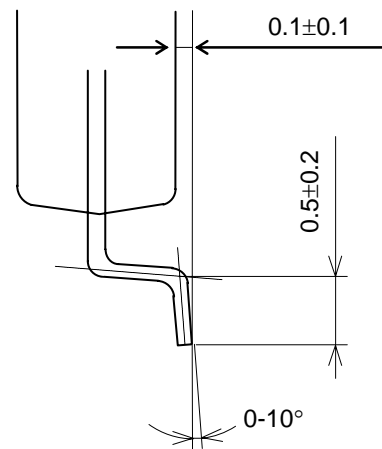
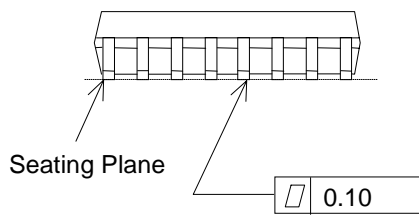

NOTE: Dimension "*" does not include mold flash.

■ **Material & Lead finish**

- Package molding compound: Epoxy
- Lead frame material: Cu
- Lead frame surface treatment: Solder plate (Pb Free)

MARKING

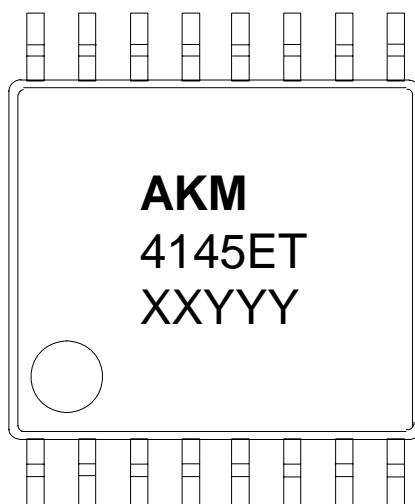

- 1) Pin #1 indication
- 2) Date Code : XXYYY (5 digits)
 XX: Lot#
 YYY: Date Code
- 3) Marketing Code : 4145ET
- 4) Asahi Kasei Logo

REVISION HISTORY

Date (YY/MM/DD)	Revision	Reason	Page	Contents
08/08/25	00	First Edition		
10/09/17	01	Specification Change	25	PACKAGE The package dimension was changed.

IMPORTANT NOTICE

- These products and their specifications are subject to change without notice.
When you consider any use or application of these products, please make inquiries the sales office of Asahi Kasei Microdevices Corporation (AKM) or authorized distributors as to current status of the products.
- Descriptions of external circuits, application circuits, software and other related information contained in this document are provided only to illustrate the operation and application examples of the semiconductor products. You are fully responsible for the incorporation of these external circuits, application circuits, software and other related information in the design of your equipments. AKM assumes no responsibility for any losses incurred by you or third parties arising from the use of these information herein. AKM assumes no liability for infringement of any patent, intellectual property, or other rights in the application or use of such information contained herein.
- Any export of these products, or devices or systems containing them, may require an export license or other official approval under the law and regulations of the country of export pertaining to customs and tariffs, currency exchange, or strategic materials.
- AKM products are neither intended nor authorized for use as critical components^{Note1)} in any safety, life support, or other hazard related device or system^{Note2)}, and AKM assumes no responsibility for such use, except for the use approved with the express written consent by Representative Director of AKM. As used here:
 - Note1) A critical component is one whose failure to function or perform may reasonably be expected to result, whether directly or indirectly, in the loss of the safety or effectiveness of the device or system containing it, and which must therefore meet very high standards of performance and reliability.
 - Note2) A hazard related device or system is one designed or intended for life support or maintenance of safety or for applications in medicine, aerospace, nuclear energy, or other fields, in which its failure to function or perform may reasonably be expected to result in loss of life or in significant injury or damage to person or property.
- It is the responsibility of the buyer or distributor of AKM products, who distributes, disposes of, or otherwise places the product with a third party, to notify such third party in advance of the above content and conditions, and the buyer or distributor agrees to assume any and all responsibility and liability for and hold AKM harmless from any and all claims arising from the use of said product in the absence of such notification.