



AK8814

NTSC/PAL Digital Video Encoder

Notice

AKM does not ship this product (the AK8814) to customers who are not licensed by ROVI corp.

GENERAL DESCRIPTION

The AK8814 is low voltage, low power and small packaged Digital Video Encoder. It is suitable for a STB or Digital TV. It converts ITU-R.BT601/656 standard 8-bit parallel data into analog composite video signal, S-video in NTSC and PAL formats.

AK8814 supports Macrovision Copy Protection Rev.7.1, Closed Captioning and Video Blanking ID(CGMS-A) and WSS. These functions are controlled by high-speed I²C Bus interface.

FEATURES

- NTSC-M, PAL-B,D,G,H,I,M,N encoding.
- Simultaneous composite video signal and S-video signal outputs
- ITU-R BT.656 4:2:2 8-bit Parallel Input
 - EAV Decoding
- Master/Slave Operation
 - Digital Field Sync I/O
 - Digital Vertical/Horizontal Sync I/O
- Y filtering 2 x over-sampling
- C filtering 4 x over-sampling
- Single 27MHz Clock (The polarity could be inverted by SYSINV pin)
- Triple 10-bit DACs
- I²C Bus Interface (400kHz)
- Closed Caption encoding (NTSC: line 21,284-SMPTE PAL: line 22,335-CCIR)
- Macrovision Copy Protection Rev. 7.1*
- VBID, CGMS-A(EIAJ CPR-1024)
- WSS
- On-chip color bar generator
- Low power consumption
- 2.8V to 3.3V operation CMOS Monolithic
- 48pin LQFP Package

* This device is protected by U.S. patent numbers 4,631,603, 4,577,216, and 4,819,098, and other intellectual rights. The use of Macrovision's copy protection technology in the device must be authorized by Macrovision and is intended for home and other limited pay-per-view use only, unless otherwise authorized in written by Macrovision. Reverse engineering or disassembly is prohibited.

Block Diagram

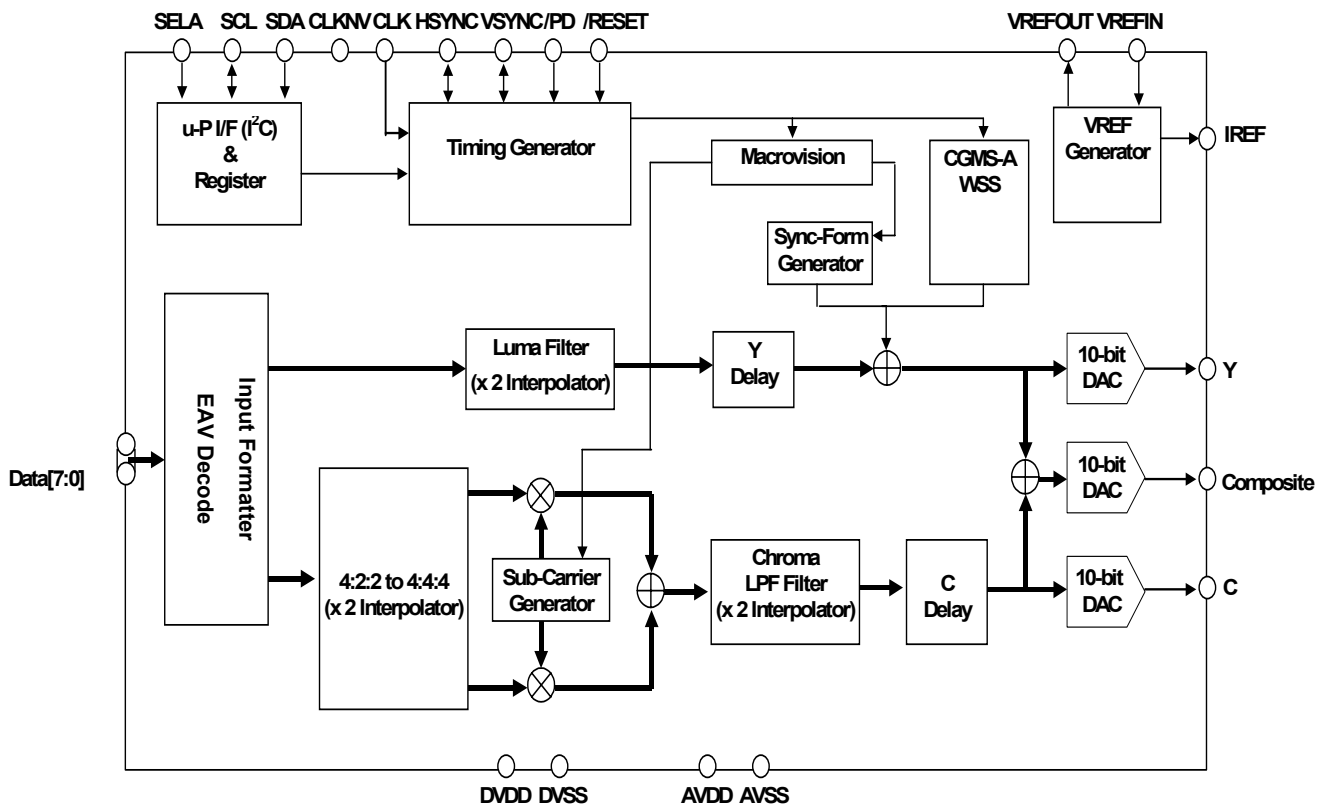

PIN LAYOUT

48pin LQFP

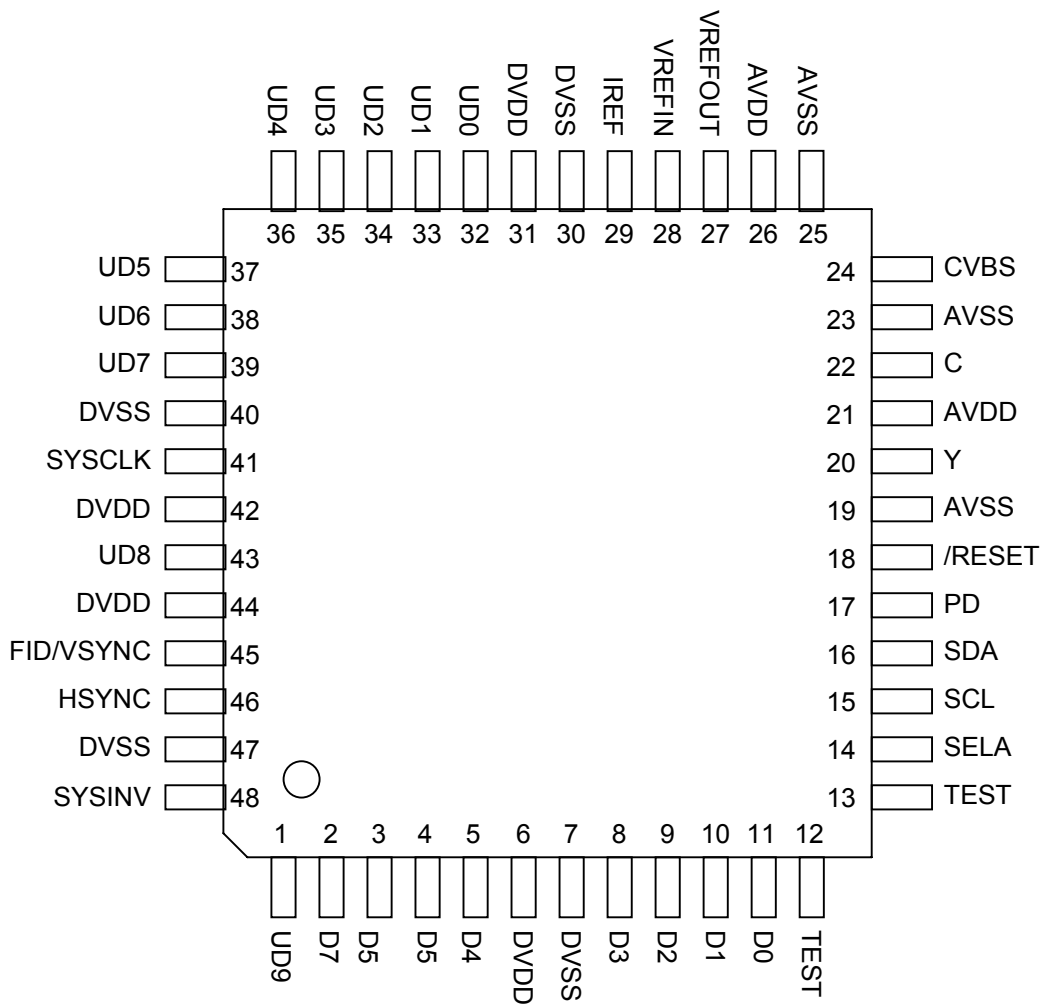

PIN/FUNCTION			
No.	Pin Name	I/O	Description
1	UD9	I/O	Test pin. Open for normal operation
2-5, 8-11	D7 - D0	I	27MHz 8-Bit 4:2:2 multiplexed Y,Cb,Cr Data Input. For Rec.656 format, AK8814 decodes EAV. For non-Rec.656 format (without EAV), AK8814 operates in Master or Slave mode.
12-13	TEST	I	Test pin. Ground for normal operation
14	SELA	I	The slave address is set with this pin. "L":40H "H":42H
15	SCL	I	Serial interface clock
16	SDA	I/O	Serial interface data
17	PD	I	Power Down Pin. After returning from PD mode to normal operation, RESET Sequence should be done to AK8814.
18	/RESET	I	After this pin becomes "L", AK8814 starts the internal initializing sequence. After initializing sequence, AK8814 is set NTSC mode, Rec.656 decoding mode. All DACs Off condition. After power up, AK8814 must be initialized with this pin. (27MHz Clock is necessary for reset sequence.)
20	Y	O	Output of Luminance Signal.
22	C	O	Output of the Chrominance signal
24	COMPOSITE	O	Output of Composite Video signal
27	VREFOUT	O	Output of the Internal Vref. Terminate with 0.1uF or more capacitor.
28	VREFIN	I	Input of the Reference Voltage
29	IREF	O	The currents flow this pin adjusts the full-scale output current of the DAC.
32-39	UD0-UD7	I/O	Test pin. Open for normal operation
41	SYSCLK	I	27MHz Clock Input. The polarity could be inverted by SYSINV.
43	UD8	I/O	Test pin. Open for normal operation
45	FID /VSYNC	I/O	Either of FID or VSYNC selected by the register. Rec.656 decode mode :Output Master mode : Output Slave mode : Input FID shows that "L" is odd field and "H" is even field.
46	HSYNC	I/O	Rec.656 decode mode : Output Master mode : Output Slave mode : Input
48	SYSINV	I	"L" : data is latched with rising edge. "H" : data is latched with falling edge.
21,26	AVDD	P	Analog +3.3V
6,31, 42,44	DVDD	P	Digital +3.3V
19,23,25	AVSS	G	Analog Ground
7,30, 40,47	DVSS	G	Digital Ground

(Note1) At ITU-R.BT656 I/F mode operation, FID/VSYNC, HSYNC pins should be pulled up to VDD with 100k-ohm Resistor

(Note2) This device requires reset operation. Before resetting the state of the pin of I/O are unknown state. After reset sequence, I/O pins (FID/VSYNC, HSYNC) turns Hi-Z states.

ELECTRICAL CHARACTERISTICS

Absolute Maximum Ratings

Parameter	Min	Max	Units
Supply Voltage (VDD) DVDD, AVDD	-0.3	4.6V	V
Input Pin Voltage (Vin)	-0.3	VDD+0.3	V
Input Pin Current (Iin)	-	±10	mA
Analog Reference Current (IREF)	-	0.21	mA
Analog Output Current	-	6.5	mA
Storage Temperature	-40	125	°C

(Note)When all Ground pins(DVSS, AVSS) are set to 0V.

Recommended Operating Conditions

Parameter	Min	Typ.	Max	Units
Supply Voltage (VDD)	2.8	3.3	3.6	V
Operating Temperature	-40		85	°C

DC Characteristics

[Power Supply:2.8 ~ 3.6V Temperature:-40 ~ 85°C]

Parameter	Symbol	Min	Max	Units	Conditions
Digital Input High Voltage	VIH1	0.7VDD		V	Note1)
Digital Input Low Voltage	VIL1		0.3VDD	V	Note1)
Digital Input leak Current	IL		±10	uA	Note1)
Digital Output High Voltage	VOH	2.2		V	IOH = -1mA Note 2)
Digital Output Low Voltage	VOL1		0.4	V	IOL = 2mA Note 2)
I ² C Input High Voltage I ² C(SDA,SCL)	VIH2	0.7VDD		V	
I ² C Input Low Voltage I ² C(SDA,SCL)	VIL2		0.3VDD	V	
I ² C(SDA) Output Voltage	VOL2		0.4	V	IOL = 3mA

Note 1) D[9:0],FID/VSYNC, HSYNC, SYSCLK, /RESET pin

Note 2) FID/VSYNC, HSYNC pin

Note 3) Connected Test Pin to Ground, SELA and SYSINV Pin are desired polarity.

Analog Characteristics and Dissipation Current

[Power Supply:3.3V Temperature:25°C]

Parameter	Min	Typ	Max	Units	Conditions
DAC Resolution		10		bit	
DAC Integral linearity error		±0.6	± 2	LSB	
DAC Differential linearity error		±0.4	± 1	LSB	
DAC Output Full Scale Voltage	1.21	1.28	1.35	V	Note1)
DAC Output offset Voltage			5.0	mV	Note2)
Unbalances between DACs		±1	±5	%	Note3)
Isolation between DACs		50		dB	1MHz Full Scale
DAC Load Capacitance			30	pF	Note4)
Internal Reference Voltage	1.17	1.235	1.30	V	
Internal Reference Drift		-50		ppm/°C	
DAC Current (Active mode)		24		mA	Note5)
DAC Current (Sleep mode)		10		uA	Note6)
Total Current		50	65	mA	Note7)
Power Down Current		10	100	uA	

Note 1) Under the condition of output load 220Ω, IREF pin with 6.8kΩ, using internal reference. The output full-scale current IOU_T is calculated as Full scale output voltage (typ. 1.28V) /220Ω=typ. 5.82mA.

Note 2) DAC output when feeding code of 0 (Decimal).

Note 3) Deviation between the DAC output when feeding 1V generating code of 800(Decimal).

Note 4) The value is a design target. This value is not tested.

Note 5) All DACs are operating.

Note 6) All DACs are turned off with no system clock.

Note 7) NTSC internal color bar with 3ch DACs operation and slave mode operation. DAC output pins is connected with only 220Ω load.

AC Characteristics (2.8V - 3.6V Temperature -40 ~ 85°C)

1. SYSCLK

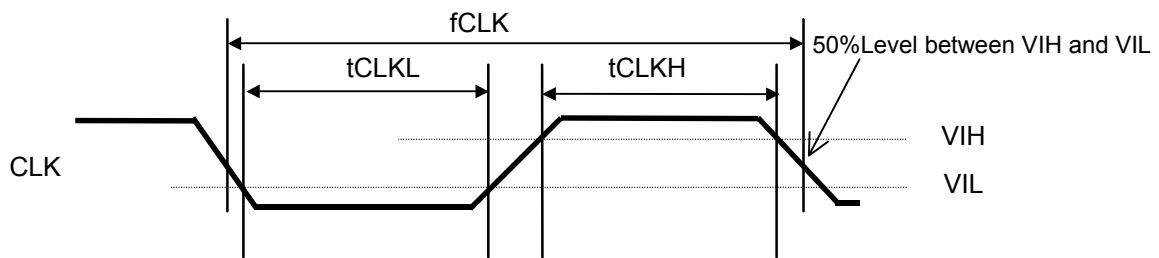

Parameter	Symbol	Min.	Typ.	Max	Unit
SYSCLK	f_{SYSCLK}		27		MHz
SYSCLK Pulse width H	t_{CLKH}	15			nsec
SYSCLK Pulse width L	t_{CLKL}	15			nsec

(2). Pixel Data Input Timing

(2-1) SYSINV = Low

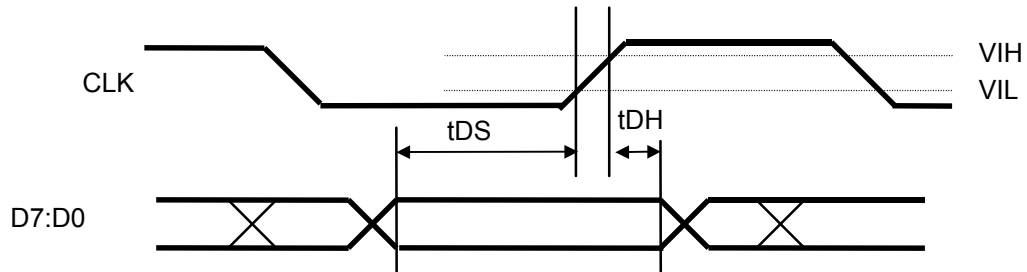

(2-2) SYSINV = High

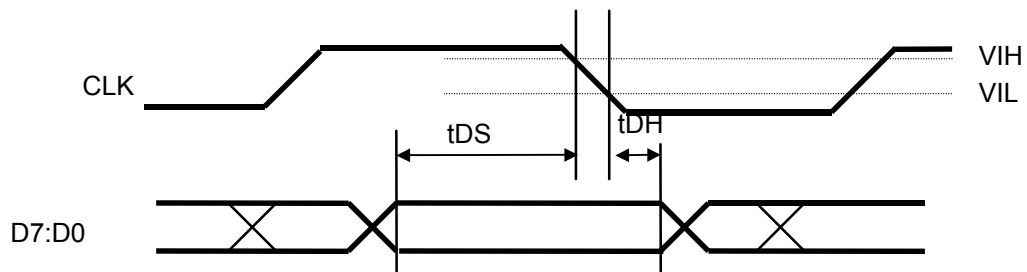

Parameter	Symbol	Min	Typ	Max	Units
Data Setup Time	tDS	5			nsec
Data Hold Time	tDH	8			nsec

(3). Synchronizing Signal (FID/VSYNC, HSYNC)

(3-1) SYSINV=Low

(3-1-1) Input Timing

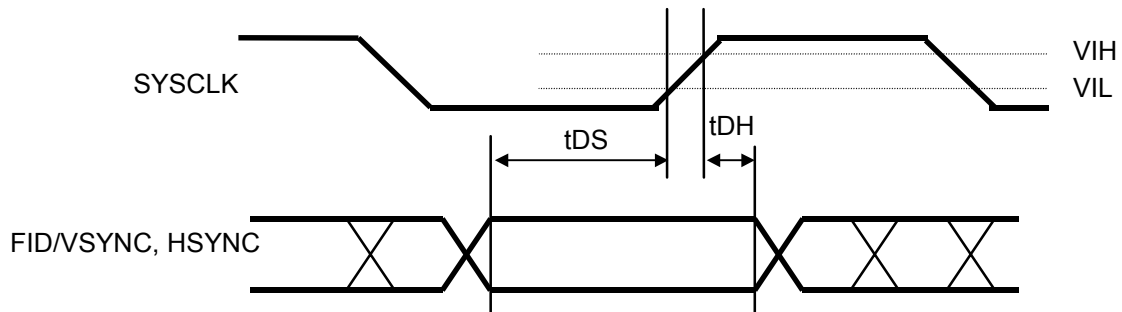

Parameter	Symbol	Min	Typ.	Max	Units
Data Setup Time	t_{DS}	5			nsec
Data Hold Time	t_{DH}	8			nsec

(3-1-2) Output Timing

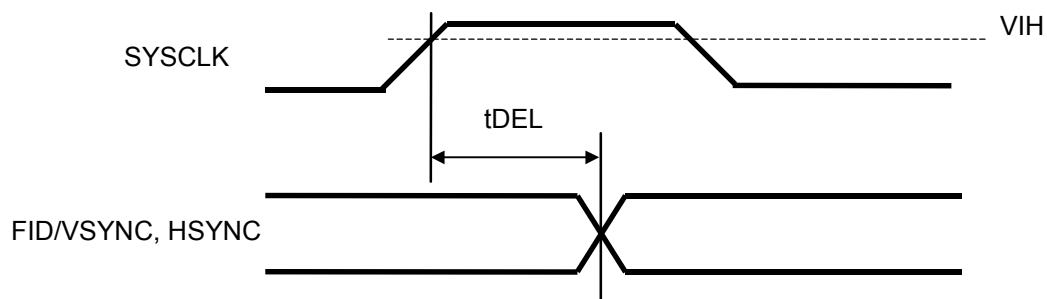

Parameter	Symbol	Min	Typ.	Max	Units
Delay from SYSCLK	t_{DEL}			27	nsec

(3-2) SYSINV = High

(3-2-1) Input Timing

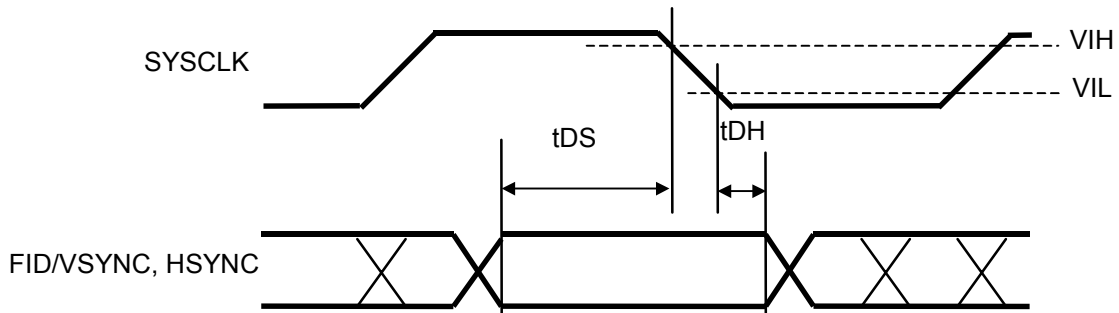

Parameter	Symbol	Min	Typ.	Max	Units
Data Setup Time	t_{DS}	5			nsec
Data Hold Time	t_{DH}	8			nsec

(3-2-2) Output Timing

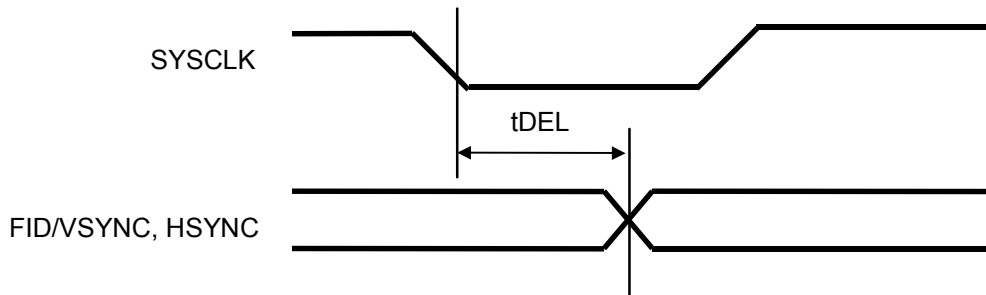

Parameter	Symbol	Min	Typ.	Max	Units
Delay from SYSCLK	t_{DEL}			27	nsec

(4). Reset (Initialize)

Reset Timing

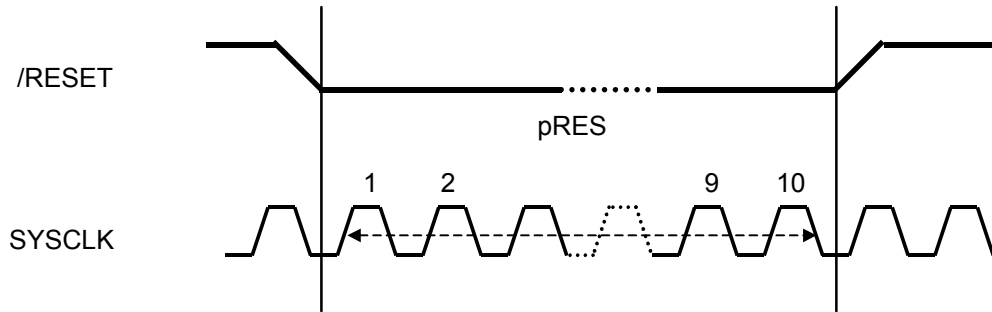

Parameter	Symbol	Min	Typ.	Max	Units
/RESET Pulse Width	pRES	10			SYSCLK

(5) Power Down Sequence

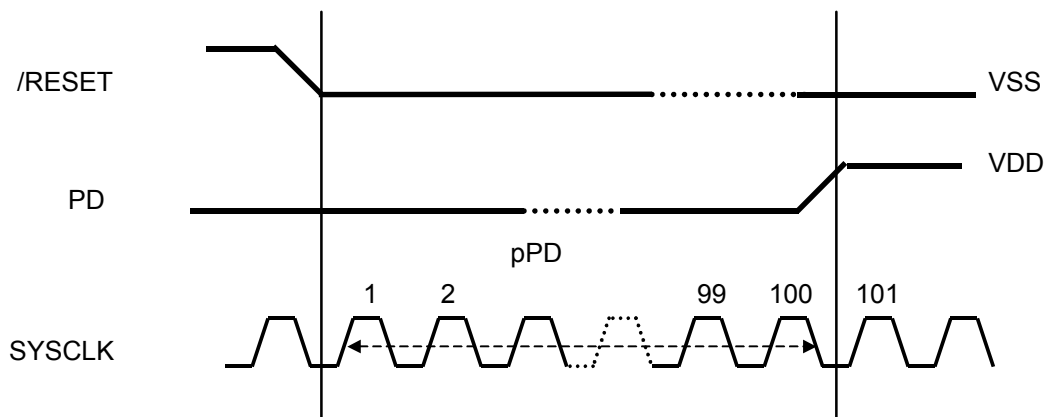

Parameter	Symbol	Min	Typ.	Max	Units
/RESET Pulse Width	pSTOP	100			SYSCLK

(4). I²C Bus (SCL 400kHz cycle mode)

(4-1) I/O Timing 1

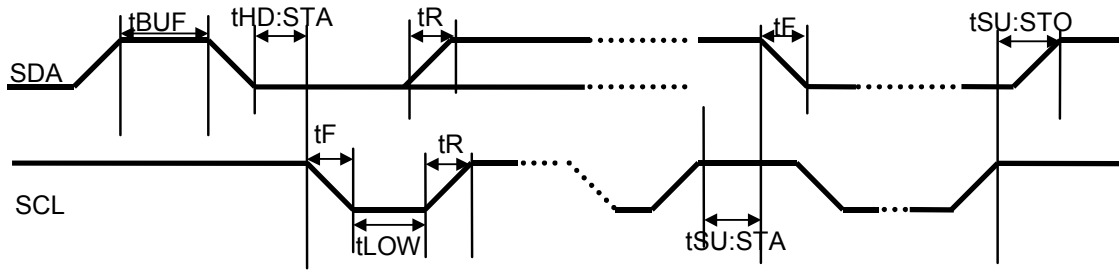

Parameter	Symbol	Min	Max	Units
Bus Free Time	tBUF	1.3		usec
Hold Time (Start Condition)	tHD:STA	0.6		usec
Clock Pulse Low Time	tLOW	1.3		usec
Bus Signal Rise Time	tR		300	nsec
Bus Signal Fall Time	tF		300	nsec
Setup Time(Start Condition)	tSU:STA	0.6		usec
Setup Time(Stop Condition)	tSU:STO	0.6		usec

All the figures shown above list are not restricted by AK8814 but are restricted by I²C Bus standard.
Please see the I²C Bus standard for further details.

(4-2) I/O Timing 2

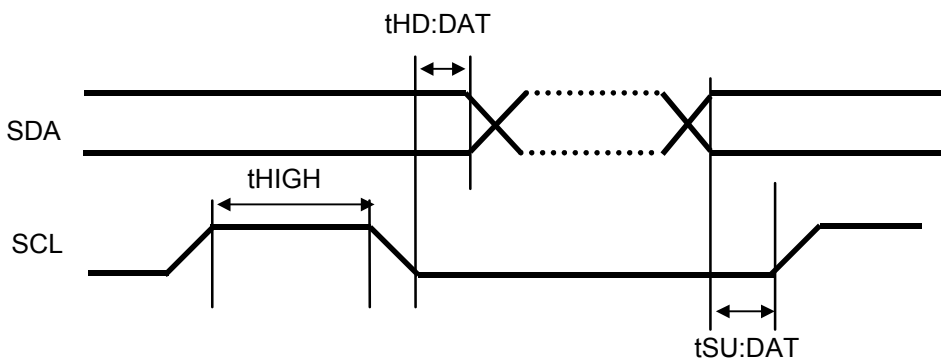

Parameter	Symbol	Min.	Max.	Unit.
Data Setup Time	tSU:DAT	100 (1)		nsec
Data Hold Time	tHD:DAT	0.0	0.9 (2)	usec
Clock Pulse High Time	tHIGH	0.6		usec

(1) In case of normal I²C bus mode tSU:DAT ≥ 250nsec

(2) Using under minimum tLOW, this value must be satisfied.

FUNCTIONAL DESCRIPTION

◆ Reset

When the reset pin [/RESET] set to "L", AK8814 is in reset state. AK8814 starts in the internal initializing sequence at the trailing edge of the first SYSCLK after the reset pin is "L". All internal registers are set to be default value by this initializing sequence. AK8814 needs at least 10 clock counts of SYSCLK for this reset operation. After the reset operation, the video output pins are in high-impedance. AK8814 requires SYSCLK for the reset operation.

◆ Master Clock

AK8814 requires 27MHz clock at SYSCLK pin for operation. Video input data (ITU-R BT.656) is sampled at the trailing edge of this 27MHz. SYSINV decides the edge direction.

SYSINV = L Data is sampled at rising edge of SYSCLK.

SYSINV = H Data is sampled at falling edge of SYSCLK.

◆ Video Signal Interface

AK8814 can interface with the video input data by the following 3 modes. The mode is set by the register [Interface mode register(00H)].

1. ITU-R BT.656 Format

AK8814 decodes EAV in stream data and manages an internal synchronization.

In this case, AK8814 outputs FID (odd : "L" even : "H")/ VSYNC and HSYNC.

CCIR-bit of [Interface mode register (00H)] should be set "1" .

2. ITU-R BT.656 like Format (4:2:2 Y/Cb/Cr)

There are Master and Slave modes, for ITU-R BT.656 like Format which does not include EAV. In this mode, CCIR-bit of [Interface mode register(00H)] should be set "0" .

<Master Mode>

AK8814 provides FID/VSYNC and HSYNC to an external device according to the AK8814 internal timing counter. AK8814 starts to sample the input data at the fixed value on the internal pixel counter.

In this mode, following setting should be done to [Interface mode register(00H)].

CCIR-bit = 0

MAS-bit = 1

<Slave Mode>

FID/VSYNC and HSYNC are supplied by an external device. AK8814 samples the data as same manner of Master mode.

In this mode, following setting should be done to [Interface mode register(00H)].

CCIR-bit = 0

MAS-bit = 0

◆ Video Signal Conversion

Video reconstruction module converts the multiplexed data (ITU-R. BT601 Y/Cb/Cr) to the interlace format of NTSC-M, PAL-M, PAL-B,D,G,H,I,N and other formats (ex. NTSC-4.43 and PAL60). The video reconstruction format, the line number, the color encode way(NTSC or PAL) and the frequency of Color Sub-carrier is specified by [Video Process 1 register(01H)]. (cf. Burst Signal Table) The frequency and the phase of Color Sub-carrier are also adjustable by [Sub C. Freq. register(06H)] and [Sub C. Phase register(07H)]. The Sub-carrier has a free-running mode and a reset-mode. In the reset-mode, the Sub-carrier is reset automatically to the initial phase for every 4 fields (NTSC) or 8 fields (PAL).

◆ Luminance Filter

Luminance signal passes through the 2x Low Pass filter with $\sin(x)/x$ compensation. Fig.1 is the characteristic of Luminance Filter.

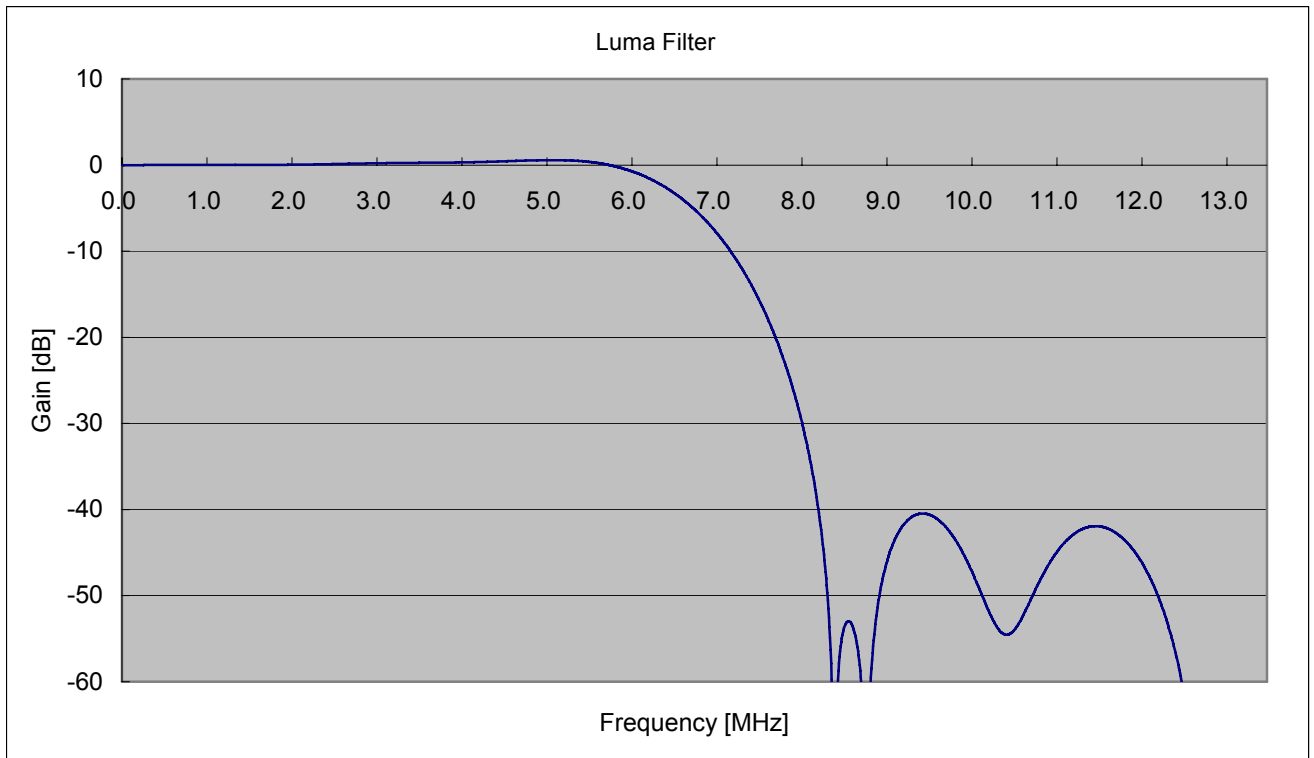

Fig. 1 Luminance Filter

◆ Chrominance Filter

Chrominance signals (Cb,Cr) before Sub-carrier modulation pass through the 1.3 MHz Low pass filter shown in Fig.2. Chrominance signal modulated by Sub-carrier passes through the filter shown in Fig.3.

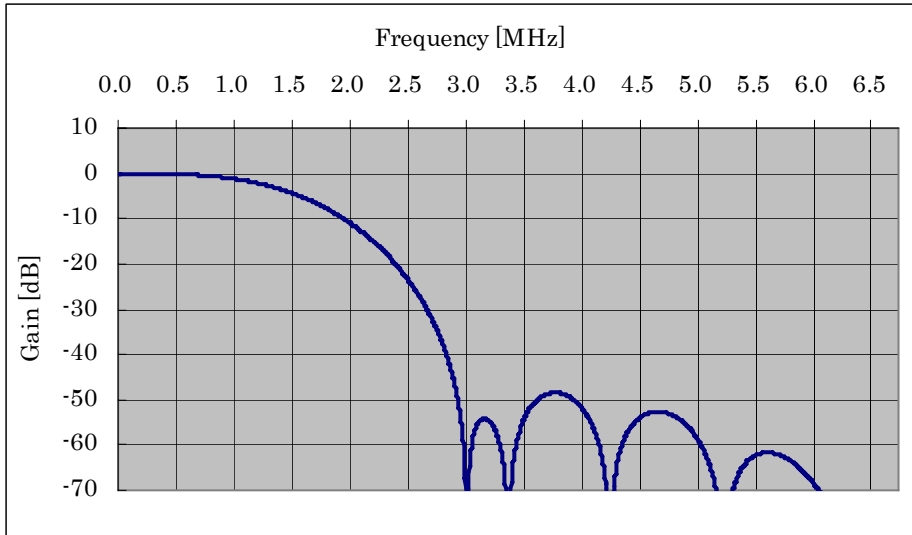

Fig. 2 Chroma-1 LPF

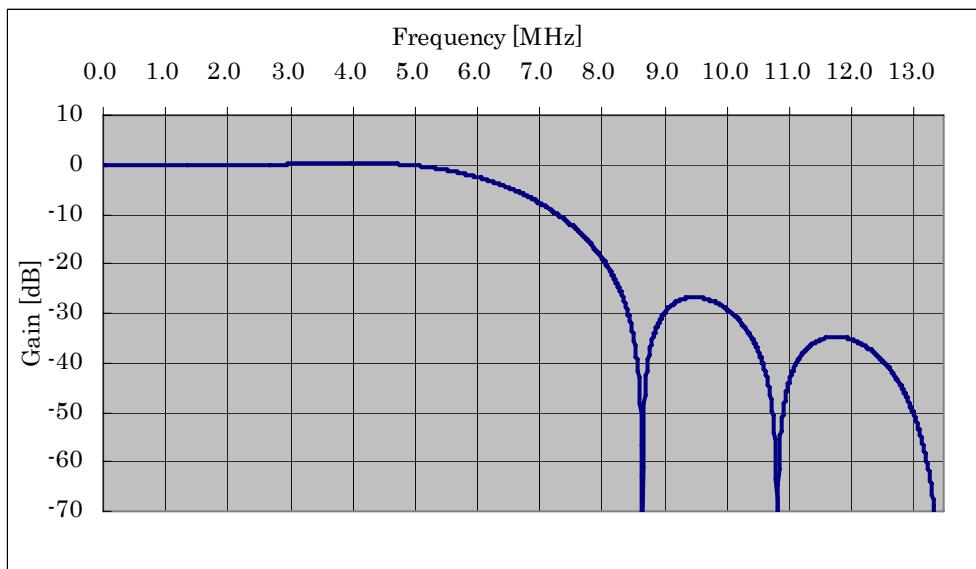

Fig. 3 Chroma-2 LPF

◆ Color burst signal

Color burst signal is generated by 32bits-length Digital Frequency Synthesizer. The Default frequency of the color burst is selected by [Video Process 1 Register(0x01)].

Standard	Sub-carrier Freq. [MHz]	Video Process 1 [VM1,VM0]
NTSC-M	3.57954545	[0,0]
PAL-M	3.57561188	[0,1]
PAL-B,D,G,H,I	4.43361875	[1,1]
PAL-N(Arg.)	3.5820558	[1,0]
PAL-N(non-Arg.)	4.43361875	[1,1]
PAL60	4.43361875	[1,1]
NTSC-4.43	4.43361875	[1,1]

Burst Signal Table

Sub-carrier frequency 3.57561188MHz is allowed when PAL-M mode is selected.

The burst frequency and initial phase resolution are as follows.

Frequency resolution	0.8046Hz
SCH Phase resolution	360°/256

◆ Video DAC

AK8814 has the three current driven 10bits-DACs at 27MHz operation. The full scale voltage of DAC is determined by the current output from IREF pin. Typical output voltage is 1.28Vo-p under the condition of VREFIN 1.235V, 6.8KΩ between IREF pin and Ground(AVSS) and DAC load resistance of 220Ω. This full-scale voltage should be set in the range of 1.17V to 1.33V by adjusting the resistor which terminates IREF pin. Each DAC output can be set to “active state” or to “inactive state” individually by [DAC Mode register(05H)]. When DAC is in “inactive state”, the output is Hi-impedance. When all DACs are set to “inactive state”, the analog part of AK8814 goes into sleep mode. In this case AK8814 stops outputting the reference voltage(VREF) output. When any DAC is switched over in “active state” from sleep mode, AK8814 starts outputting reference voltage. In this case AK8814 needs several milisecond for VREF wake-up time.

Using internal VREF as the reference voltage, connect [VREF OUT] pin with [VREF IN] pin and [VREF OUT] pin is terminated with more than 0.1uF capacitor.

◆ Use external Reference Voltage

In order to improve the accuracy of DAC output, external reference voltage may be used. In this case, VREFOUT pin still needs to be terminated with more than 0.1uF capacitor.

◆ Copy Protection

Macrovision Copy Protection Rev.7.1

Information about the Macrovision encoding functions of the AK8814 is available to Macrovision licensees.

Macrovision may be contacted at:

Macrovision Corporation
 2830 De La Cruz Boulevard
 Santa Clara, California 95050 U.S.A.

Main Telephone (switchboard): +1 408 743-8600
 Main Fax: +1 408 743-8610
 Technical Support Group Fax: +1 408 743-8617

Macrovision Register is same as AK8812

Register		bit-7	bit-6	bit-5	bit-4	bit-3	bit-2	bit-1	bit-0
0x0A	:CSP32	-	-	-	-	CPS32[3]	CPS32[2]	CPS32[1]	CPS32[0]
0x0B	CPS31:CPS30	CPS31[3]	CPS31[2]	CPS31[1]	CPS31[0]	CPS30[3]	CPS30[2]	CPS30[1]	CPS30[0]
0x0C	CPS29:CPS28	CPS29[3]	CPS29[2]	CPS29[1]	CPS29[0]	CPS28[3]	CPS28[2]	CPS28[1]	CPS28[0]
0x0D	CPS27:CPS26	CPS27[3]	CPS27[2]	CPS27[1]	CPS27[0]	CPS26[3]	CPS26[2]	CPS26[1]	CPS26[0]
0x0E	CPS25:CPS24	CPS25[3]	CPS25[2]	CPS25[1]	CPS25[0]	CPS24[3]	CPS24[2]	CPS24[1]	CPS24[0]
0x0F	CPS23:CPS22	CPS23[3]	CPS23[2]	CPS23[1]	CPS23[0]	CPS22[3]	CPS22[2]	CPS22[1]	CPS22[0]
0x10	CPS21:CPS20	CPS21[3]	CPS21[2]	CPS21[1]	CPS21[0]	CPS20[3]	CPS20[2]	CPS20[1]	CPS20[0]
0x11	CPS19:CPS18	CPS19[3]	CPS19[2]	CPS19[1]	CPS19[0]	CPS18[3]	CPS18[2]	CPS18[1]	CPS18[0]
0x12	CPS17:CPS16	CPS17[3]	CPS17[2]	CPS17[1]	CPS17[0]	CPS16[3]	CPS16[2]	CPS16[1]	CPS16[0]
0x13	CPS15:CPS14	CPS15[3]	CPS15[2]	CPS15[1]	CPS15[0]	CPS14[3]	CPS14[2]	CPS14[1]	CPS14[0]
0x14	CPS13:CPS12	CPS13[3]	CPS13[2]	CPS13[1]	CPS13[0]	CPS12[3]	CPS12[2]	CPS12[1]	CPS12[0]
0x1D	CPC1:CPC0	CPC1[3]	CPC1[2]	CPC1[1]	CPC1[0]	CPC0[3]	CPC0[2]	CPC0[1]	CPC0[0]
0x1E	CPS11:CPS10	CPS11[3]	CPS11[2]	CPS11[1]	CPS11[0]	CPS10[3]	CPS10[2]	CPS10[1]	CPS10[0]
0x1F	CPS9:CPS8	CPS9[3]	CPS9[2]	CPS9[1]	CPS9[0]	CPS8[3]	CPS8[2]	CPS8[1]	CPS8[0]
0x20	CPS7:CPS6	CPS7[3]	CPS7[2]	CPS7[1]	CPS7[0]	CPS6[3]	CPS6[2]	CPS6[1]	CPS6[0]
0x21	CPS5:CPS4	CPS5[3]	CPS5[2]	CPS5[1]	CPS5[0]	CPS4[3]	CPS4[2]	CPS4[1]	CPS4[0]
0x22	CPS3:CPS2	CPS3[3]	CPS3[2]	CPS3[1]	CPS3[0]	CPS2[3]	CPS2[2]	CPS2[1]	CPS2[0]
0x23	CPS1:CPS0	CPS1[3]	CPS1[2]	CPS1[1]	CPS1[0]	CPS0[3]	CPS0[2]	CPS0[1]	CPS0[0]

◆ Closed Caption and Extended Data

AK8814 supports both Closed Captioning and Extended Data. They are controlled “ON” or ”OFF” respectively by [Video Process 2 Register(02H)]. Each data consists of 2 continuous bytes register(Closed Caption R (16H,17H)), and it is recognized as the data is renewed when the second byte(17H register) is written in the register. After the data is renewed, AK8814 encodes Closed Captioning and Extended Data at the designated line. If the data isn’t renewed, AK8814 outputs “ASCII-NULL” code. The data is supposed as Odd Parity and 7 bit US-ASCII code. Host should provide a parity bit.

*In PAL encoding mode, AK8814 outputs them at the same timing and same pattern as NTSC.

*The line where Closed Captioning data is encoded is as follows.

	525/60 System (SMPTE)	625/50 System (CCIR)
Closed Caption	21 Line default	22 Line default
Extended Data	284 Line default	335 Line default

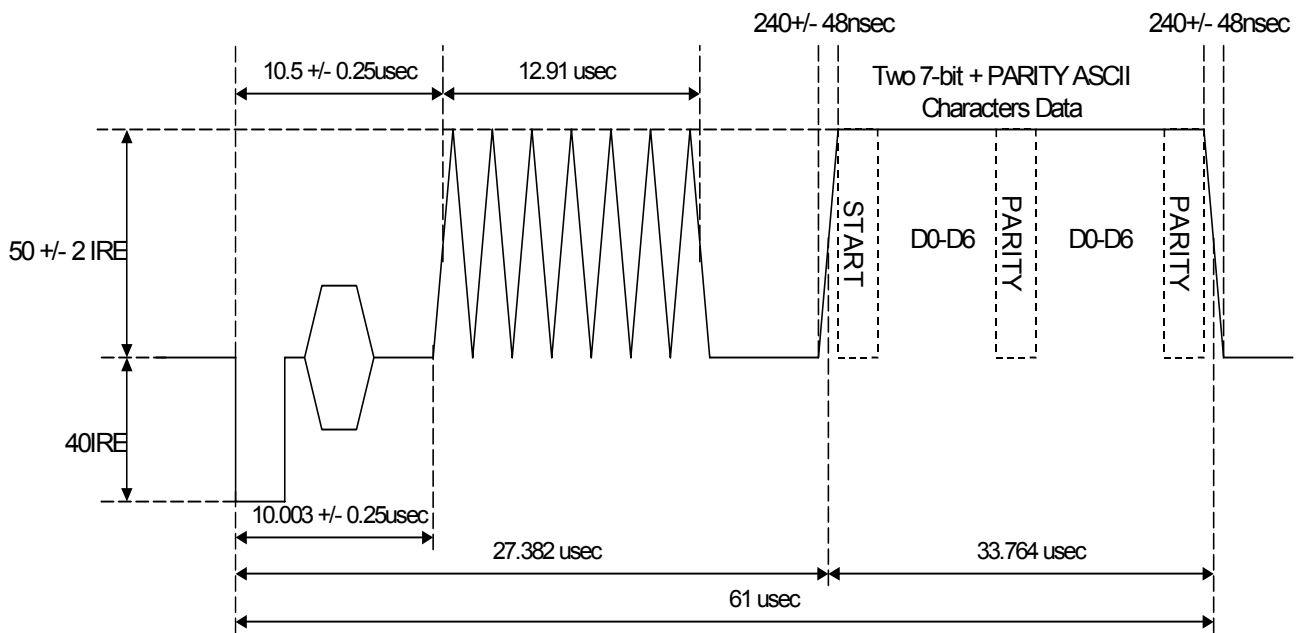

Fig. 4 Closed Captioning Wave form

◆ Video ID

AK8814 supports Video ID (EIAJ standard, CPR-1204) encoding for the distinction of an aspect ratio or CGMS-A etc. Setting or Resetting the VBID-bit of [Video Process 2 Register(02H)], this function is switched On/Off. The data is set by using [Video ID Data Register(1AH, 1BH)].

VBID Data Renewal Timing.

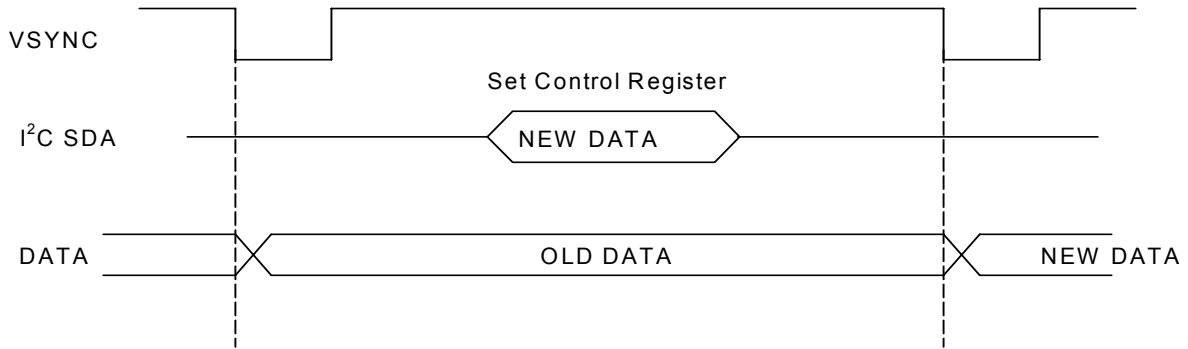

Fig. 5 VBID Data renewal Timing

VBID Data Layout

VBID is consists of 20 bits and its format is shown as follows.

AK8814 generates CRC code automatically and appends it to the data. Initial value of the Polynomial is 1.

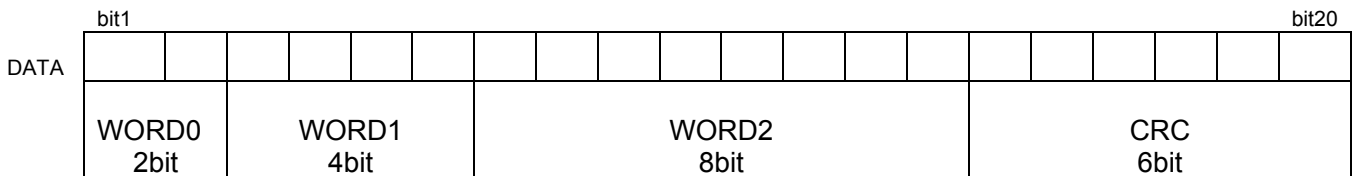

Fig. 6 VBID code assignment

VBID Waveform

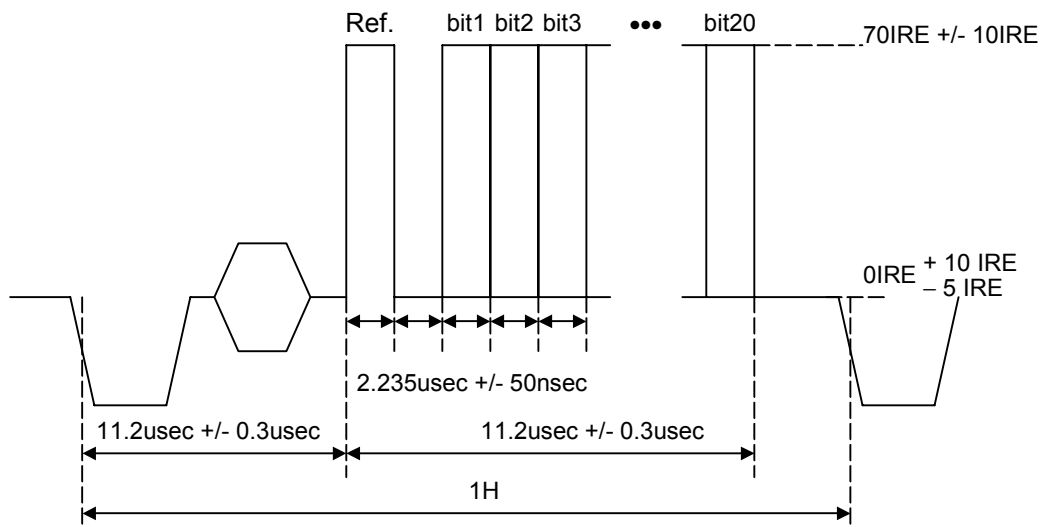

Fig. 7 VBID Wave Form

	525/60 system	625/50 system
Amplitude	70 IRE	490 mV
Encode Line	20/283	20/333

VBID parameter table

◆ WSS

AK8814 supports WSS(ITU-R.Bt.1119) encoding for the distinction of an aspect ratio etc. Setting or Resetting the WSS-bit of [Video Process 2 Register(02H)], this function is switched On/Off. The data is set by using [WSS Data Register(08H, 09H)].

WSS Data Renewal Timing

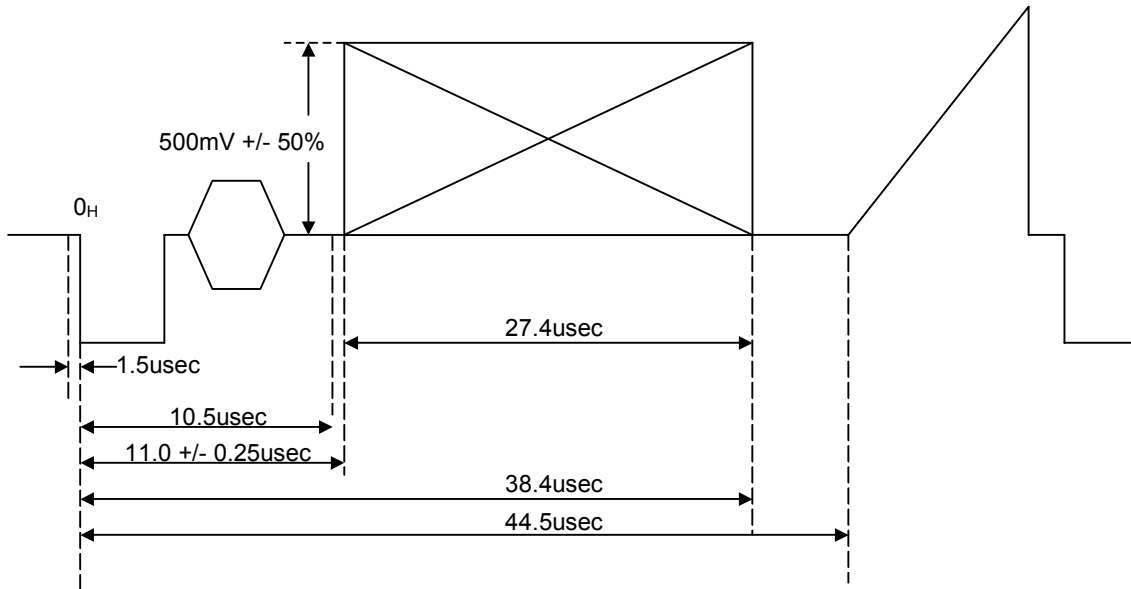
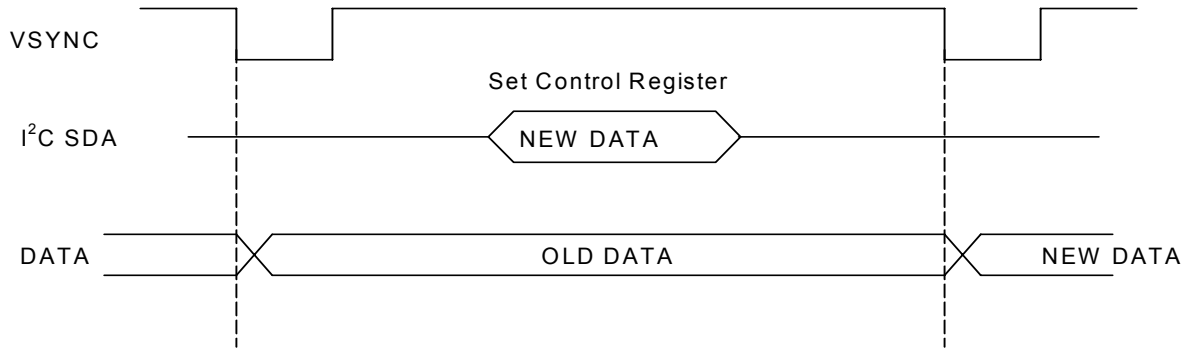

Encode Line: Line 23
 Coding: bi-phase modulation coding
 Clock: 5MHz (Ts = 200ns)

Run-in	Start code	Group 1 Aspect ratio	Group 2 Enhanced Services	Group 3 Subtitles	Group4 Reserved
29 elements	24 elements	24 elements	24 elements	18 elements	18 elements
		Bit numbering 0 1 2 3 LSB MSB	Bit numbering 4 5 6 7 LSB MSB	Bit numbering 8 9 10 LSB MSB	Bit numbering 11 12 13 LSB MSB
		0 : 000111 1 : 111000	0 : 000111 1 : 111000	0 : 000111 1 : 111000	0 : 000111 1 : 111000
0x1F1C71C7	0x1E3C1F				

◆ **AK8814 Interface Timing (Part 1) Master mode & ITU-R BT. 656 mode**

On ITU-R BT.656 decoding mode or master mode operation, AK8814 outputs HSYNC and FID or VSYNC (selected by register).

When AK8814 receives ITU-R BT. 656 signal, AK8814 decodes [EAV] code in the data for synchronization then outputs the HSYNC. AK8814 outputs HSYNC at the rising edge of SYSCLK in the timing of the 32nd/24th(NTSC/PAL) data slot, which is counted from the [EAV] starting point as below. (See also AC Characteristics 2-2[Input Synchronizing Signal])

On master mode operation, the front device connected with AK8814 (ex. MPEG Decoder) starts to set Cb on the 276th/288th(NTSC/PAL) slot, after starting to count HSYNC falling edge as 32nd/24th(NTSC/PAL) slot.

FID/VSYNC is output synchronously with HSYNC at the timing of solid line as in Fig. 10 Video Field.

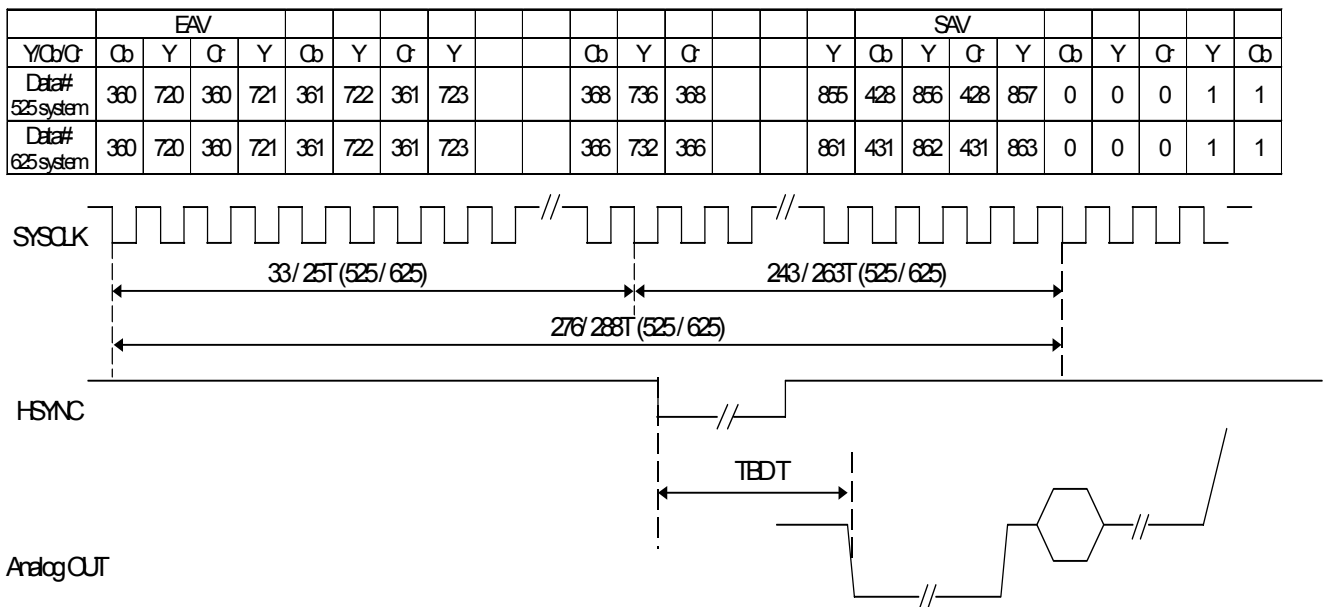

Fig. 8 Interface Timing (ITU-R BT.656 or Master mode)

◆ **AK8814 Interface Timing (Part 2) Slave mode**

On slave mode operation, HSYNC and FID or VSYNC (Selected by register) are input to AK8814.

AK8814 monitors the transition of HSYNC at the timing of the rising edge of SYSCLK. (Refer to AC Characteristic 2-1. [Input Synchronizing Signal]) After AK8814 recognizes HSYNC is Low-logic, AK8814 sets the slot number to the 32nd/24th(NTSC/PAL), internally, then AK8814 starts to sample the data as Cb on 276th/288th(NTSC/PAL) slot.

Video field is recognized the transition timing between FID/VSYNC and HSYNC. (Fig.10. Video Field) As in the figure, there is a tolerance of $\pm 1/4H$.

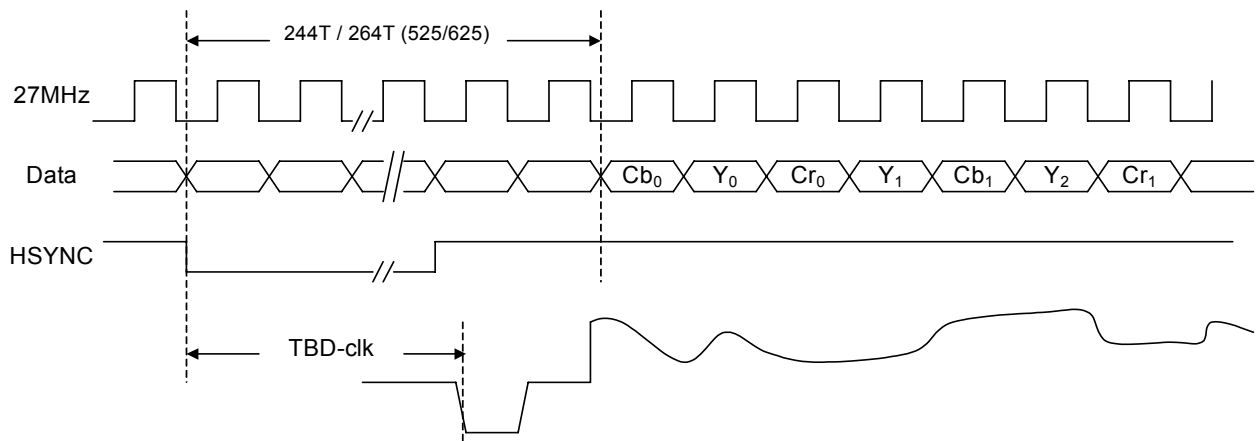
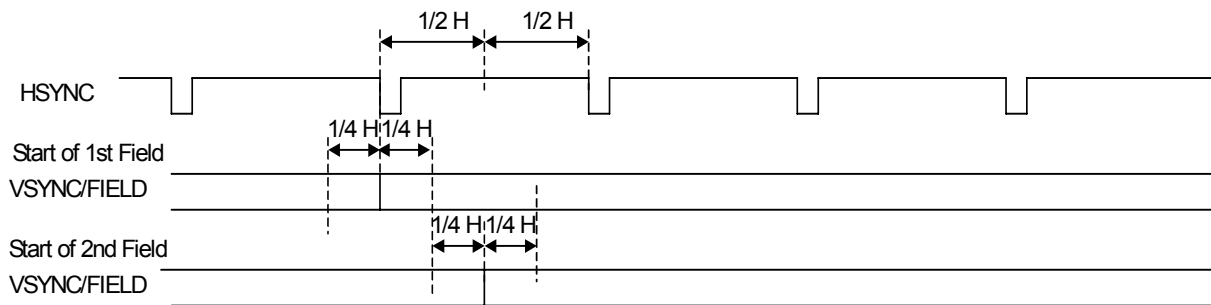

Fig. 9. Interfacing timing (Slave mode)



ig. 10. Video Field

F

◆ HSYNC FID/VSYNC Timing

525 System

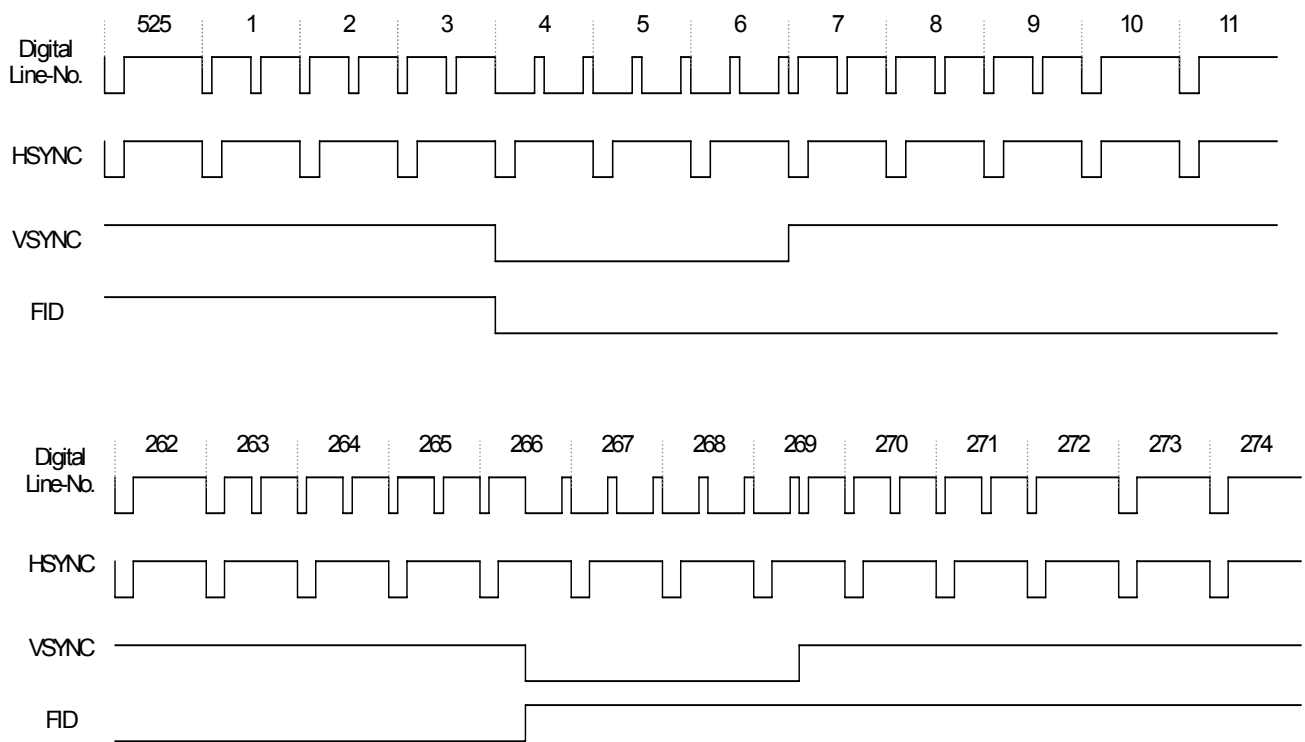

625 System

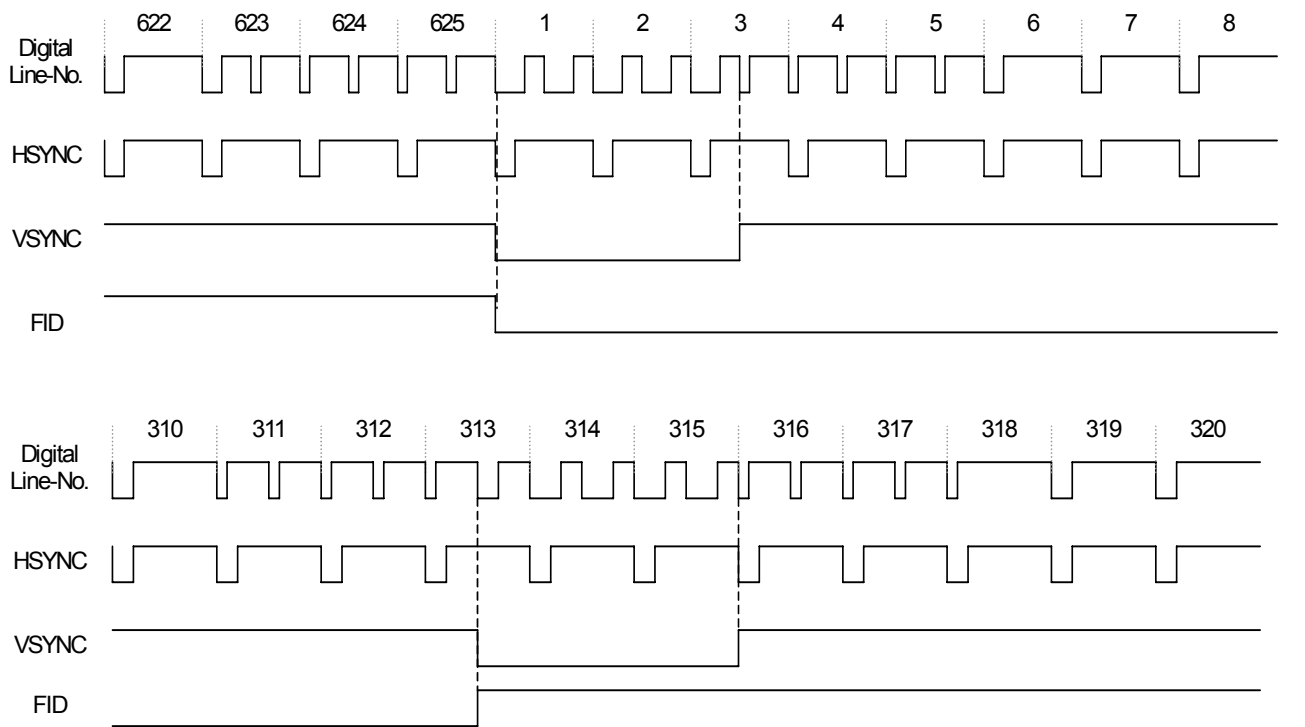

◆ Internal Color Bars Generator

AK8814 generates the Common Color Bar signal for NTSC and PAL internally. The generated Color Bar is “100% Amplitude, 100% Saturation”. When AK8814 is set to Black Burst output mode, AK8814 does not output Color bar even Color bar output register is set.

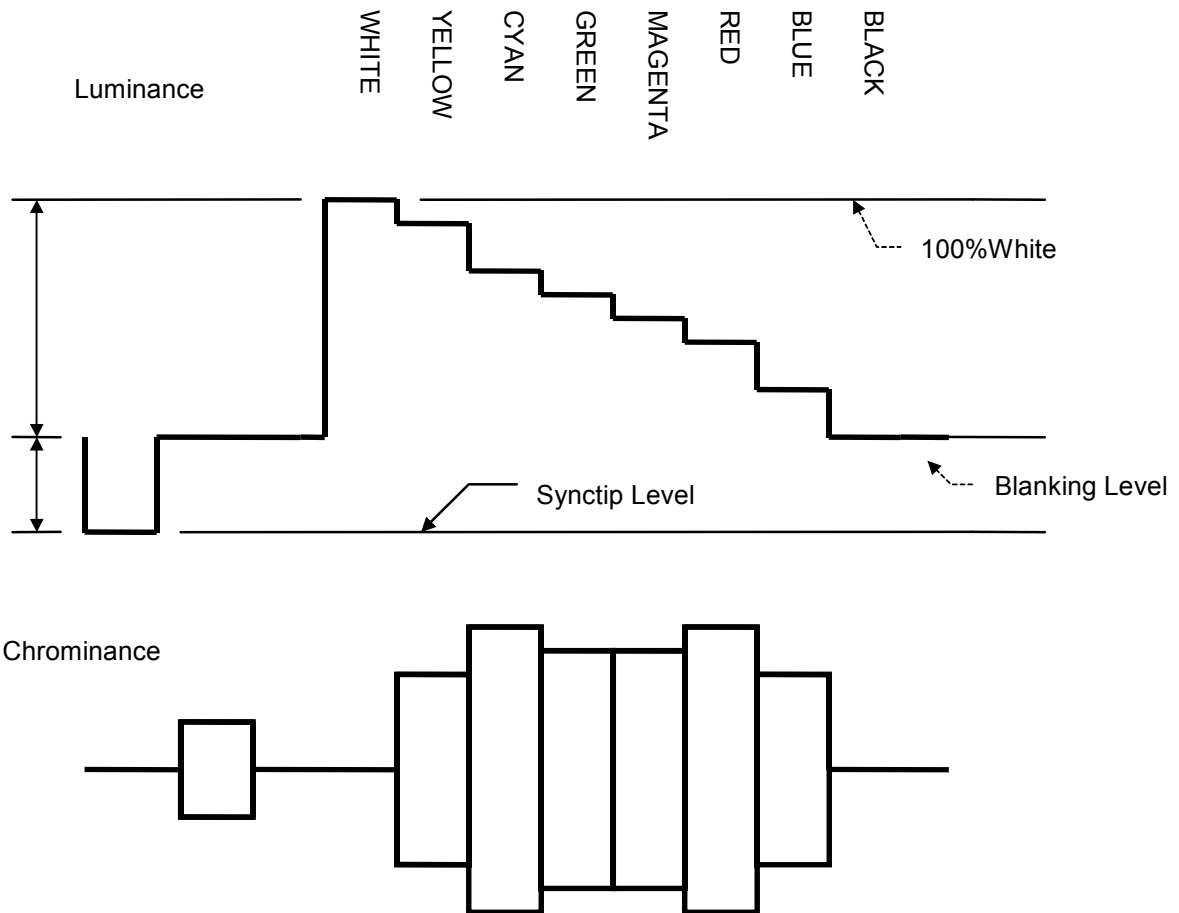

The following values are code for ITU-R. BT601

	WHITE	YELLOW	CYAN	GREEN	MAGENTA	RED	BLUE	BLACK
Cb	128	16	166	54	202	90	240	128
Y	235	210	170	145	106	81	41	16
Cr	128	146	16	34	222	240	110	128

◆ Internal Black Burst Generator

AK8814 generates Black burst signal for NTSC and PAL internally. When AK8814 is set to Black burst output mode, AK8814 works same operation as that the input Y/Cb/Cr data is 16/128/128. In this mode, AK8814 does not output Color bar even Color bar output register is set.

◆ I²C Control Sequence

AK8814 is controlled by I²C bus. The slave address can be selected as 40H or 42H by selecting SELA pin.

SELA	SLAVE Address
PULL Down [Low]	0x40
PULL UP [High]	0x42

Operation :

Write Sequence:

(a) 1byte Write Sequence

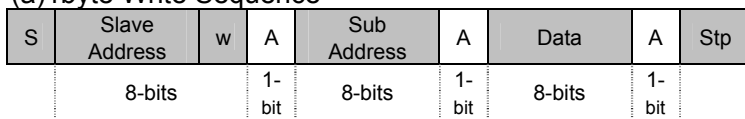

(b) Sequential Write Operation

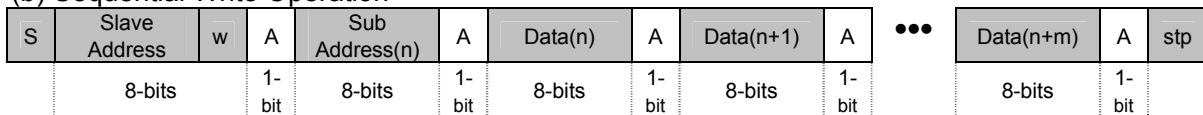

Read Sequence:

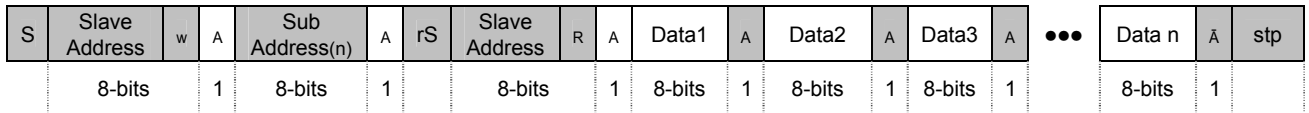

- S, rS : Start Condition
- A : Acknowledge (SDA Low)
- Ā : Not Acknowledge (SDA High)
- stp : Stop Condition
- R/W 1 : Read 0 : Write

: Master device (Host)

: Slave device (AK8814)

Sub Address	Name	R/W	Explanation
00H	Interface Mode	R/W	Setting Interface mode
01H	Video Process 1	R/W	Setting Standard (NTSC, PAL etc.)
02H	Video Process 2	R/W	Setting Closed Caption/Extended Data/VBID
03H	Video Process 3	R/W	Setting Composite signal or Component Signal Adjusting Chrominance/Luminance Delay
04H	RESERVED		
05H	DAC Mode	R/W	Each DAC On/Off Switch
06H	Sub C. Freq.	R/W	Adjusting Sub-carrier frequency
07H	Sub C. Phase	R/W	Adjusting Sub-carrier phase
08H	WSS Data 1	R/W	WSS Data Register
09H	WSS Data 2	R/W	WSS Data Register
1AH-15H	RESERVED	R/W	
16H	Closed Caption R	R/W	Closed Caption Lower byte Data
17H	Closed Caption R	R/W	Closed Caption Upper byte Data
18H	Closed Caption R	R/W	Extended Lower byte Data
19H	Closed Caption R	R/W	Extended Upper byte Data
1AH	Video ID Data	R/W	Video ID Lower byte Data
1BH	Video ID Data	R/W	Video ID Upper byte Data
1CH-23H	RESERVED		
24H	STS Data	R	Status
25H	Device ID	R	Device ID
26H	Device REV	R	Revision
27H-29H	RESERVED		

Interface Mode Register (R/W only default A4H)

Sub Add	bit 7	bit 6	bit 5	bit 4	bit 3	bit 2	bit 1	bit 0
00H	BLN4	BLN3	BLN2	BLN1	BLN0	FID	MAS	CCIR

Symbol	Value	Description	
BLN4 - BLN0	*****	Line Blanking No.	default 10100
FID	0 1	Select VSYNC Select FID	default
MAS	0 1	Slave mode Master mode	default
		When CCIR=0,it's valid	
CCIR	0 1	CCIR656 non-decode CCIR656 decode	default

Video Process 1 Register (R/W only default 18H)

Sub Add	bit 7	bit 6	bit 5	bit 4	bit 3	bit 2	bit 1	bit 0
01H	Reserved	CBG	SETUP	SCR	VM3	VM2	VM1	VM0

Symbol	Value	Description	
CBG	0 1	Video Encode Generates color bar	default
SETUP	0 1	No Set-up 7.5 IRE Set-up	default
SCR	0 1	Sub C. Phase Reset off Standard Field Reset	default
VM3 - VM2	00 01 10 11	525/60 525/60 PAL (PAL-M etc.) Reserved PAL	default
VM1-VM0	00 01 10 11	3.57954545 MHz 3.57561188 MHz (PAL-M only) 3.5820558 MHz 4.43361875 MHz	default

Register Setting of each standard is showend as following ;

	VM3-VM0
NTSC-M	0000
PAL-B,D,G,H,I	1111
PAL-M	0101
PAL-60	0111
NTSC4.43	0011

- When SCR is "ON", the Subcarrier Phase is reset every 4 fields for NTSC, every 8 fields for PAL.
- Even when SETUP is "ON", there is no Set-up (Pedestal) during the blanking lines.

Video Process 2 Register (R/W only default 00H)

Sub Add	bit 7	bit 6	bit 5	bit 4	bit 3	bit 2	bit 1	bit 0
02H	Reserved	Reserved	Reserved	Reserved	WSS	CC284	CC21	VBID

Symbol	Value	Description	
CC284	0	Extended Data OFF	default
	1	ON	
CC21	0	Closed Caption OFF	default
	1	ON	
VBID	0	Video ID OFF	default
	1	ON	
WSS	0	WSS OFF	default
	1	ON	

Video Process 3 Register (R/W only default 00H)

Sub Add	bit 7	bit 6	bit 5	bit 4	bit 3	bit 2	bit 1	bit 0
03H	Reserved	VS	SYD2	SYD1	SYD0	CYD2	CYD1	CYD0

Symbol	Value	Description	
SYD2 - SYD0		S-Video Y Component delay no. from Chroma: 2's comp.	default 000
CYD2 - CYD0		Composite Y Component delay no. from Chroma: 2's comp.	default 000

- S-video and Y component of the composite signal can be shifted for the chroma signal independently at ± 3 -system clock (27MHz).

DAC Mode Register (R/W only default 00H)

Sub Add	bit 7	bit 6	bit 5	bit 4	bit 3	bit 2	bit 1	bit 0
05H	Reserved	Reserved	Reserved	Reserved	Reserved	OUTCP	OUTC	OUTY

Symbol	Value	Description	
OUTCP	0	Composite video signal or U signal output : OFF	default
	1	Composite video signal or U signal output : ON	
OUTC	0	Chroma signal or V signal output : OFF	default
	1	Chroma signal or V signal output : ON	
OUTY	0	Y signal output : OFF	default
	1	Y signal output : ON	

- Video output of AK8814 (DAC) can be forced “OFF” independently.
The output of DAC that is forced “OFF” is Hi-impedance. When three DACs are forced “OFF”, then the internal VREF is also forced “OFF”. In this case, it takes several milliseconds before the internal VREF reaches the proper voltage after any DAC becomes “ON”.

SubC Freq. Register (R/W only default 00H)

Sub Add	bit 7	bit 6	bit 5	bit 4	bit 3	bit 2	bit 1	bit 0
06H	SUBF7	SUBF6	SUBF5	SUBF4	SUBF3	SUBF2	SUBF1	SUBF0

Symbol	Value	Description	
SUBF7-SUBF0		Adjustment of frequency between +127 and -128 step of 0.8Hz	default 0

- AK8814 generates the necessary sub-carrier frequency from a system clock by DFS (Digital Frequency Synthesizer)
- Frequency of default is adjustable by specifying this bit. This bit adjusts the default frequency.

SubC Phase Register (R/W only default 00H)

Sub Add	bit 7	bit 6	bit 5	bit 4	bit 3	bit 2	bit 1	bit 0
07H	SUBP7	SUBP6	SUBP5	SUBP4	SUBP3	SUBP2	SUBP1	SUBP0

Symbol	Value	description	
SUBP7 – SUBP0		Step: (360° /256)	default 0

- Sub- carrier phase is adjustable by (360° /256) step.

WSS Data Register (R/W only default 00H)

Sub Add	bit 7	bit 6	bit 5	bit 4	bit 3	bit 2	bit 1	bit 0
08H	G2-7	G2-6	G2-5	G2-4	G1-3	G1-2	G1-1	G1-0
09H	Reserved	Reserved	G4-13	G4-12	G4-11	G3-10	G3-9	G3-8

- Please write value 0 at Reserved bit.

Closed Caption Register (R/W only default 00H)

Sub Add	bit 7	bit 6	bit 5	bit 4	bit 3	bit 2	bit 1	bit 0
16H	CC1[7]	CC1[6]	CC1[5]	CC1[4]	CC1[3]	CC1[2]	CC1[1]	CC1[0]
17H	CC2[7]	CC2[6]	CC2[5]	CC2[4]	CC2[3]	CC2[2]	CC2[1]	CC2[0]
18H	CC3[7]	CC3[6]	CC3[5]	CC3[4]	CC3[3]	CC3[2]	CC3[1]	CC3[0]
19H	CC4[7]	CC4[6]	CC4[5]	CC4[4]	CC4[3]	CC4[2]	CC4[1]	CC4[0]

Symbol	Description
CC1[7] – CC1[0]	Line 21 –1 Closed Caption
CC2[7] – CC2[0]	Line 21 –2
CC3[7] – CC3[0]	Line 284 -1 Extended Data
CC4[7] – CC4[0]	Line 284 -2

- When the 2nd byte of Closed Caption Data and Extended Data is written in, AK8814 recognizes the renewed data and encodes it in the video line. When the data is not renewed AK8814 outputs NULL code.

Video ID Data Register (R/W only default 00H)

Sub Add	bit 7	bit 6	bit 5	bit 4	bit 3	bit 2	bit 1	bit 0
1AH	Reserved	Reserved	bit 1	bit 2	bit 3	bit 4	bit 5	bit 6
1BH	bit 7	bit 8	bit 9	bit 10	bit 11	bit 12	bit 13	bit 14

- Please write value 0 at Reserved bit.
- Bit numbers correspond to Fig. 5 VBID code assignment.
- AK8814 generates CRC 6 bit data automatically.

Followings are read only register

STATUS REGISTER (R only)

Sub Add	bit7	bit6	bit5	bit4	bit3	bit2	bit1	bit0
24H	Reserved	Reserved	EN284	EN21	SYNC	STS2	STS1	STS 0

Symbol	Value	Description
EN284	0	Wait for the appointed video line to encode.
	1	Ready for the C.C. data input to the register.
EN21	0	Wait for the appointed video line to encode.
	1	Ready for the C.C. data input to the register.
SYNC	0	Missing synchronization in slave mode.
	1	Synchronization was achieved.
STS2 - STS 0	***	Shows the processing field No.

- Status Register becomes effective when SYNC bit turns to “1”. When in master mode operation, this bit is “1”.
- STS2-STS2 holds the field number of processing. Some time lag is inevitable for the I²C acquisition.
- Closed caption data should be renewed after firm that the EN* flag is “1”. EN* flag bit is cleared after the second byte(Sub address 17H,19H) was accessed.
- Reserved-bit is always value 0.

Sub Add	bit7	bit6	bit5	bit4	Bit3	bit2	bit1	bit0
25H	0	0	0	1	0	1	0	0

- Represents device ID. 14H is assigned for AK8814.

Device REV (R only default 01H)

Sub Add	bit7	bit6	bit5	bit4	Bit3	bit2	bit1	bit0
26H	0	0	0	0	0	0	0	1

- Represents device revision. Initial is 01H.

Macrovision Register Map

Register		bit-7	bit-6	bit-5	bit-4	bit-3	bit-2	bit-1	bit-0
0x0A	:CSP32	-	-	-	-	CPS32[3]	CPS32[2]	CPS32[1]	CPS32[0]
0x0B	CPS31:CPS30	CPS31[3]	CPS31[2]	CPS31[1]	CPS31[0]	CPS30[3]	CPS30[2]	CPS30[1]	CPS30[0]
0x0C	CPS29:CPS28	CPS29[3]	CPS29[2]	CPS29[1]	CPS29[0]	CPS28[3]	CPS28[2]	CPS28[1]	CPS28[0]
0x0D	CPS27:CPS26	CPS27[3]	CPS27[2]	CPS27[1]	CPS27[0]	CPS26[3]	CPS26[2]	CPS26[1]	CPS26[0]
0x0E	CPS25:CPS24	CPS25[3]	CPS25[2]	CPS25[1]	CPS25[0]	CPS24[3]	CPS24[2]	CPS24[1]	CPS24[0]
0x0F	CPS23:CPS22	CPS23[3]	CPS23[2]	CPS23[1]	CPS23[0]	CPS22[3]	CPS22[2]	CPS22[1]	CPS22[0]
0x10	CPS21:CPS20	CPS21[3]	CPS21[2]	CPS21[1]	CPS21[0]	CPS20[3]	CPS20[2]	CPS20[1]	CPS20[0]
0x11	CPS19:CPS18	CPS19[3]	CPS19[2]	CPS19[1]	CPS19[0]	CPS18[3]	CPS18[2]	CPS18[1]	CPS18[0]
0x12	CPS17:CPS16	CPS17[3]	CPS17[2]	CPS17[1]	CPS17[0]	CPS16[3]	CPS16[2]	CPS16[1]	CPS16[0]
0x13	CPS15:CPS14	CPS15[3]	CPS15[2]	CPS15[1]	CPS15[0]	CPS14[3]	CPS14[2]	CPS14[1]	CPS14[0]
0x14	CPS13:CPS12	CPS13[3]	CPS13[2]	CPS13[1]	CPS13[0]	CPS12[3]	CPS12[2]	CPS12[1]	CPS12[0]
0x1D	CPC1:CPC0	CPC1[3]	CPC1[2]	CPC1[1]	CPC1[0]	CPC0[3]	CPC0[2]	CPC0[1]	CPC0[0]
0x1E	CPS11:CPS10	CPS11[3]	CPS11[2]	CPS11[1]	CPS11[0]	CPS10[3]	CPS10[2]	CPS10[1]	CPS10[0]
0x1F	CPS9:CPS8	CPS9[3]	CPS9[2]	CPS9[1]	CPS9[0]	CPS8[3]	CPS8[2]	CPS8[1]	CPS8[0]
0x20	CPS7:CPS6	CPS7[3]	CPS7[2]	CPS7[1]	CPS7[0]	CPS6[3]	CPS6[2]	CPS6[1]	CPS6[0]
0x21	CPS5:CPS4	CPS5[3]	CPS5[2]	CPS5[1]	CPS5[0]	CPS4[3]	CPS4[2]	CPS4[1]	CPS4[0]
0x22	CPS3:CPS2	CPS3[3]	CPS3[2]	CPS3[1]	CPS3[0]	CPS2[3]	CPS2[2]	CPS2[1]	CPS2[0]
0x23	CPS1:CPS0	CPS1[3]	CPS1[2]	CPS1[1]	CPS1[0]	CPS0[3]	CPS0[2]	CPS0[1]	CPS0[0]

SYSTEM CONNECTION EXAMPLE

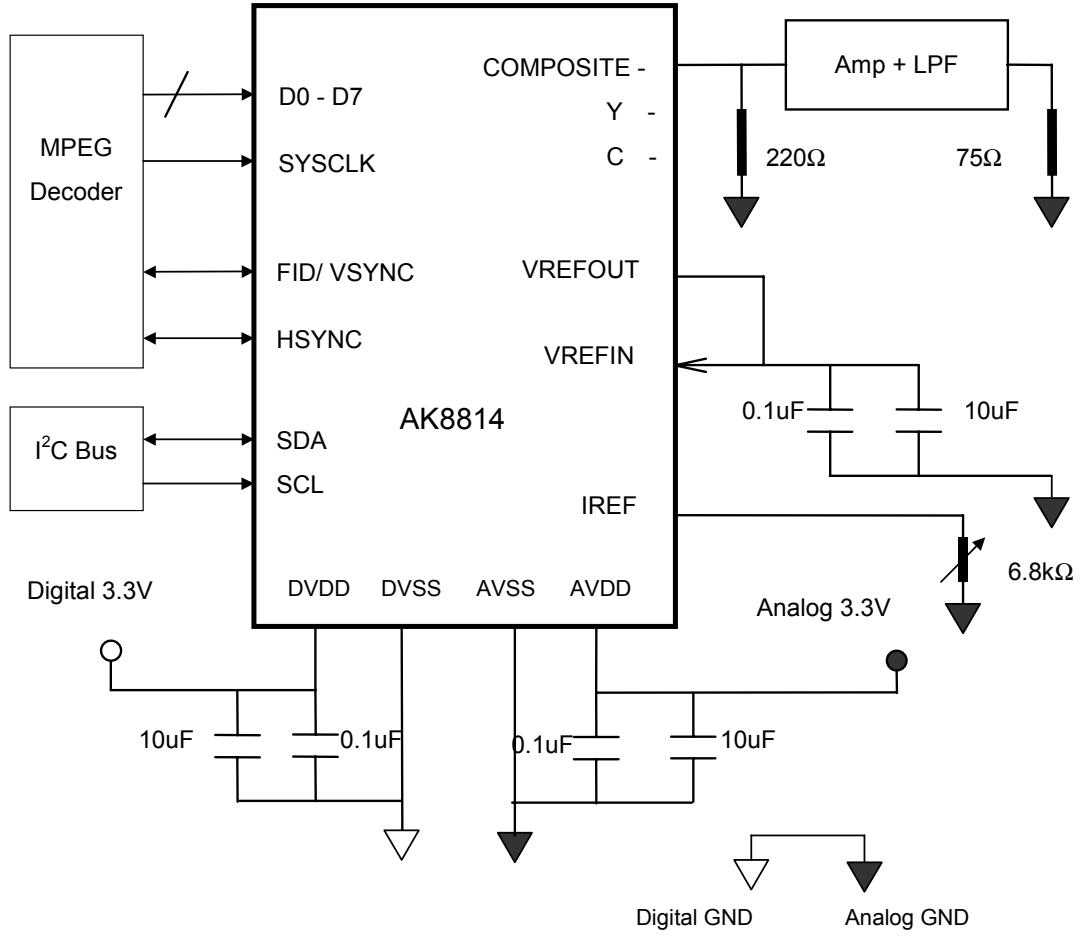

PACKAGE

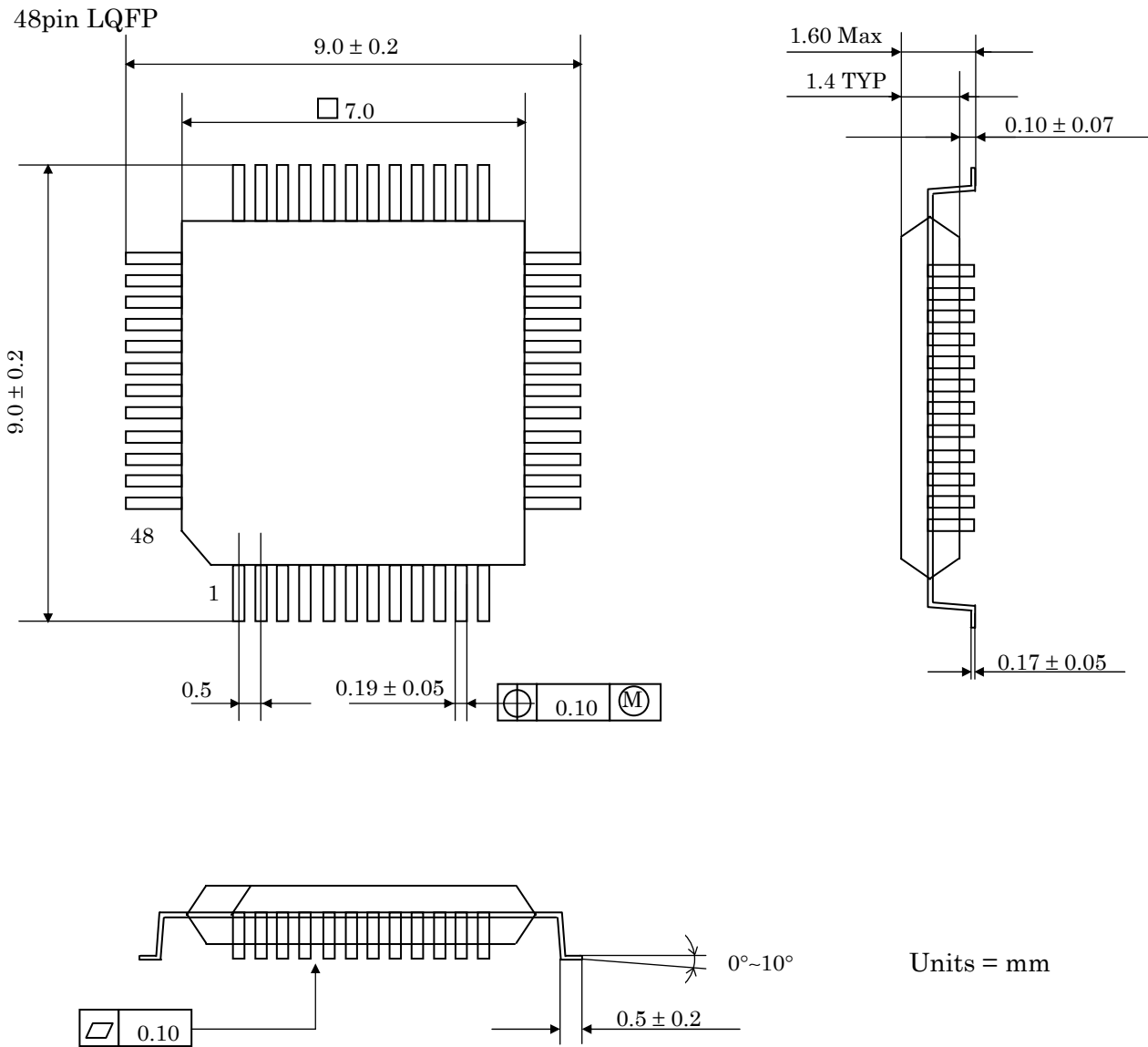

Package & Lead frame material

- Package molding compound : Epoxy
- Lead frame material : Cu
- Lead frame surface treatment : Solder plate

MARKING

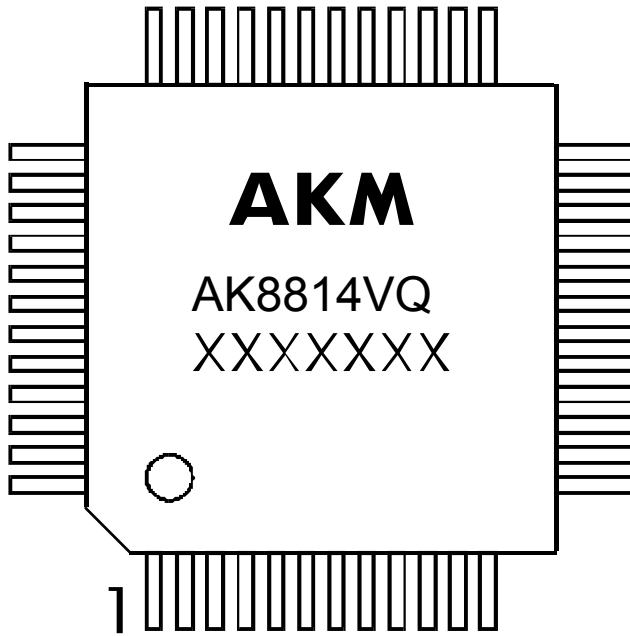

- 1) Pin #1 indication
- 2) Date Code : XXXXXXX (7 digits)
- 3) Marketing Code : AK8814
- 4) Country of Origin
- 5) Asahi Kasei Logo

IMPORTANT NOTICE

- AKEMD assumes no liability for infringement of any patent, intellectual property, or other rights in the application or use of any information contained herein.
- Any export of these products, or devices or systems containing them, may require an export license or other official approval under the law and regulations of the country of export pertaining to customs and tariffs, currency exchange, or strategic materials.
- AKEMD products are neither intended nor authorized for use as critical components>Note1) in any safety, life support, or other hazard related device or system>Note2), and AKEMD assumes no responsibility for such use, except for the use approved with the express written consent by Representative Director of AKEMD. As used here:

Note1) A critical component is one whose failure to function or perform may reasonably be expected to result, whether directly or indirectly, in the loss of the safety or effectiveness of the device or system containing it, and which must therefore meet very high standards of performance and reliability.

Note2) A hazard related device or system is one designed or intended for life support or maintenance of safety or for applications in medicine, aerospace, nuclear energy, or other fields, in which its failure to function or perform may reasonably be expected to result in loss of life or in significant injury or damage to person or property.

- It is the responsibility of the buyer or distributor of an AKEMD products, who distributes, disposes of, or otherwise places the product with a third party, to notify such third party in advance of the above content and conditions, and the buyer or distributor agrees to assume any and all responsibility and liability for and hold AKEMD harmless from any and all claims arising from the use of said product in the absence of such notification.