

## DAC Type 8-bit 4-channel Electronic Volume

### Features

- 8-bit 4 channels of built-in multiplication D/A converters
- Support for external one-path, internal three-path D/A converter reference voltages
- Built-in buffer amplifier with low distortion (-60dB typ.) and rail-to-rail operation
- Support for 3V control and 5V operation because of the three-wire serial system with separate power supplies
- Operating voltage range: 2.6 to 5.5V
- Operating temperature range: -40 to +85°C
- Package: 16-pin QFNJ (3.0mm x 3.0mm x 0.70mm, 0.5-mm pitch)

### Overview

The AK2331 is an electronic volume into which 8 bit 4 channels of multiplication D/A converters are integrated on a single chip.

The reference voltage of the D/A converter can be selected from one external path (VREF pin level) and internal three paths (VSS, AVDD, AVDD/2) for each channel and it can be used as a normal D/A converter or an electronic volume that attenuates signals from input pins VIN0 to VIN3. A buffer amplifier is incorporated as the subsequent stage of the D/A converter, which provides rail-to-rail output and a signal with a distortion of -60dB.

In operational setting, the three-wire serial system, which synchronizes serial input (SDATA) consisting of a 4-bit address and 8-bit data with the CSN and SCLK signals, is adopted, a power supply (DVDD) is provided separately from the D/A converter, and 3V serial control and 5V D/A converter operation are enabled. In addition, settings can be made so that the AVDD/2 level, which was generated internally, is output to VOUT0 to VOUT3 pins through the buffer amplifier by bypassing the D/A converter or the buffer amplifier is powered down.

A 16-pin small and low-profile QFNJ package (3.0mm square x 0.70mm height) is employed to achieve high-density packaging.

<b>Contents</b>
-----------------

Features.....	1
Overview.....	1
Contents.....	2
Block Diagram.....	3
Pin Assignments.....	3
Block Functions.....	4
Pin Functions.....	5
Absolute Maximum Ratings.....	6
Recommended Operating Conditions.....	6
Current Consumption.....	6
Digital DC Characteristics.....	7
System Reset.....	7
Analog Characteristics.....	8
Digital AC Timing.....	11
Register Functions.....	12
Recommended External Circuit Examples.....	15
Package.....	16
Important Notice.....	17

## Block Diagram

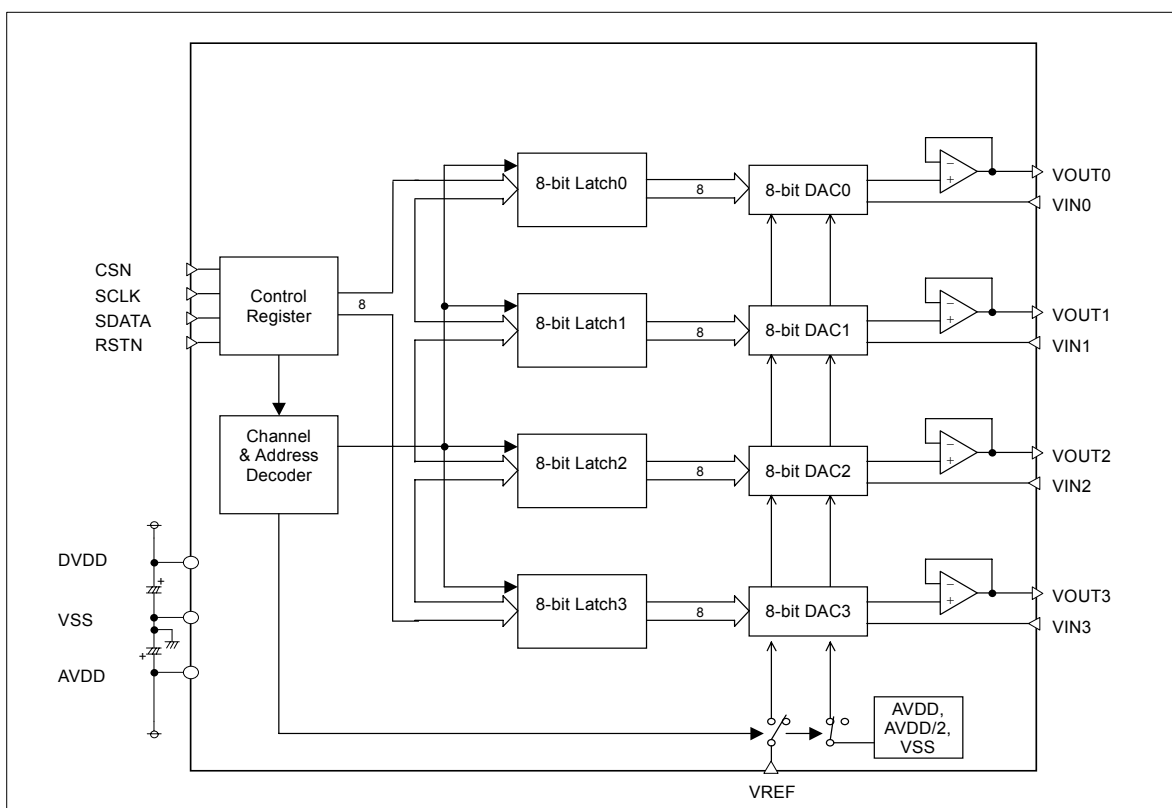

## Pin Assignments

Pin assignments (top view)

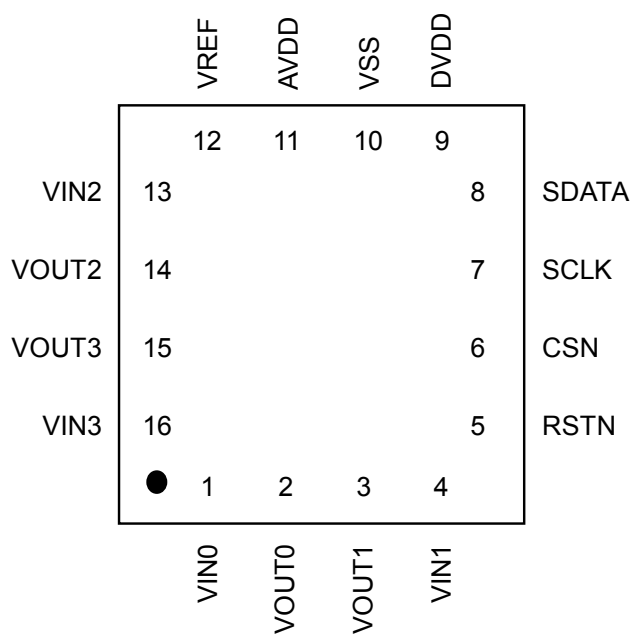

## Block Functions

Block	Function
Control register	The control register inputs serial data (SDATA) consisting of a 4-bit address and 8-bit data in sync with the CSN and SCLK signals to set register data. When a system reset is performed through the RSTN pin on power-up, all registers are initialized. The same reset (soft reset) can also be made by the SRST register (refer to register descriptions).
Channel & address decoder	The channel & address decoder decodes the data set by the control register and sets the corresponding D/A converter and reference voltage.
8-bit Latch0 to Latch3	The 8-bit Latch0 to Latch3 store the register data of the control register.
8-bit DAC0 to DAC3	The 8-bit DAC0 to DAC3 are 8-bit D/A converters set by the data latched in the previous stage.
Buffer	The buffer is a buffer amplifier that performs rail-to-rail operation.

## Pin Functions

Pin No.	Pin name	Pin type	Pin status at system reset	Function
5	RSTN	DI	Z	Reset pin
6	CSN	DI	Z	Chip select input pin for serial interface data
7	SCLK	DI	Z	Clock input pin for serial interface data
8	SDATA	DI	Z	I/O pin for serial interface data
9	DVDD	PWR	-	Digital VDD power supply pin Connect this pin to a 2.6 to 5.5V power supply. Connect a bypass capacitor of 0.1 $\mu$ F or greater between this pin and the VSS pin.
10	VSS	PWR	-	VSS power supply pin Always apply a voltage of 0V to this pin.
11	AVDD	PWR	-	Analog VDD power supply pin Connect this pin to a 2.6 to 5.5V power supply. Connect a bypass capacitor of 0.1 $\mu$ F or greater between this pin and the VSS pin. Apply a voltage so that DVDD is equal to or less than AVDD.
12	VREF	AI	Z	D/A converter reference voltage input pin
1	VIN0	AI	L	D/A converter input pin
4	VIN1	AI	L	
13	VIN2	AI	L	
16	VIN3	AI	L	
2	VOUT0	AO	Z	D/A converter/buffer amplifier output pin
3	VOUT1	AO	Z	
14	VOUT2	AO	Z	
15	VOUT3	AO	Z	

Note **A**: Analog, **D**: Digital, **PWR**: Power, **I**: Input, **O**: Output, **Z**: High-Z, **L**: Low

### Absolute Maximum Ratings

Parameter	Symbol	Min.	Max.	Unit
Power supply voltage	AVDD	-0.3	6.5	V
	DVDD	-0.3	6.5	V
Ground level	VSS	0	0	V
Input voltage	V <sub>IN</sub>	-0.3	AVDD+0.3 DVDD+0.3	V
Input current (excluding power pins)	I <sub>IN</sub>	-10	+10	mA
Storage temperature	T <sub>stg</sub>	-55	130	°C

Note All voltages are relative to the VSS pin.

Caution If the device is used in conditions exceeding these values, the device may be destroyed.  
Normal operation is not guaranteed in such extreme conditions.

### Recommended Operating Conditions

Parameter	Symbol	Condition	Min.	Typ.	Max.	Unit
Operating temperature	T <sub>a</sub>		-40		+85	°C
Operating power supply voltage	AVDD		2.6	5.0	5.5	V
	DVDD	DVDD ≤ AVDD	2.6	5.0	5.5	V
Analog output load capacity	AOC				100	pF

Note All voltages are relative to the VSS pin.

### Current Consumption

Parameter	Symbol	Condition	Min.	Typ.	Max.	Unit
Current consumption	SIDD	DVDD = AVDD = 5V VIN = AVDD, DAREF:VSS (On a system reset)		1	20	μA
	IDD1	DVDD = AVDD = 5V VIN = AVDD, DAREF:VSS VOUT[7:0] = 0x80		0.6	1.2	mA
	IDD2	DVDD = AVDD = 5V VIN = AVDD, DAREF:AVDD/2 VOUT[7:0] = 0x00		0.75	1.5	mA

Note DACREF shows the internal setting level of DAC reference voltage.  
Current consumption does not include VIN pins input current and output load current.

### Digital DC Characteristics

Parameter	Symbol	Condition	Min.	Typ.	Max.	Unit
High level input voltage	$V_{IH}$	CSN, SCLK, SDATA, RSTN	0.8DVDD			V
Low level input voltage	$V_{IL}$	CSN, SCLK, SDATA, RSTN			0.2DVDD	V
High level input current	$I_{IH}$	$V_{IH} = DVDD$ CSN, SCLK, SDATA, RSTN			1	$\mu A$
Low level input current	$I_{IL}$	$V_{IL} = 0V$ CSN, SCLK, SDATA, RSTN	-1			$\mu A$

### System Reset

Parameter	Symbol	Condition	Min.	Typ.	Max.	Unit	Remarks
Hardware reset signal input width	$t_{RSTN}$	RSTN pin	1			$\mu s$	*1)
Software reset		SRST register					*2)

- \*1) 35ms or more after power-on, be sure to perform a hardware reset operation (register initialization). When a low pulse is input for  $1\mu s$  or more, a reset is made. At this time, set the digital input (DI) pins: RSTN to high, CSN to high, and SCLK to low.

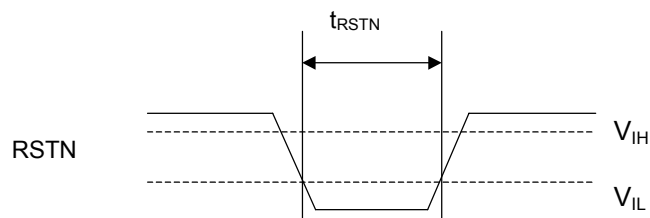

- \*2) When the SRST[7:0] register is set to 0xAA (10101010), a software reset is made. This setting initializes all registers. For details, refer to "Register Functions".

## Analog Characteristics

Unless otherwise specified, the following apply: AVDD = 4.5 to 5.5V, VSS = 0V, AVDD ≥ VIN, VREF = 0V to AVDD, Ta = -40 to +85°C.

DACREF shows an internal setting level of DAC reference voltage.

Parameter	Symbol	Condition	Min.	Typ.	Max.	Unit
VREF pin leak current	I <sub>VREF</sub>	VIN = AVDD = 5V VREF = 0V			10	μA
VREF pin input voltage range	V <sub>VREF</sub>	VIN = AVDD = 5V	0.2		AVDD-0.2	V
Resolution	RES			8		bit
Differential nonlinearity	DNL	VIN = AVDD = 5V DACREF: VSS	-1		+1	LSB
Nonlinearity *1)	INL	IAO  = 0μA VOUT = 0x02 to 0xFF	-1.5		+1.5	LSB
Buffer amplifier output voltage range	VAO1	IAO  = 0μA VIN = AVDD, DACREF: VSS VOUT[7:0] = 0x00			0.1	V
		IAO  = 0μA VIN = AVDD, DACREF: VSS VOUT[7:0] = 0xFF	AVDD-0.1			V
	VAO2	IAO  ≤ 1mA VIN = AVDD, DACREF: VSS VOUT[7:0] = 0x00			0.4	V
		IAO  ≤ 1mA VIN = AVDD, DACREF: VSS VOUT[7:0] = 0xFF	AVDD-0.4			
AVDD/2 output voltage when AVDD2O[7:0] is set	VAO3	AVDD = 5V,  IAO  ≤ 1mA	2.45	2.5	2.55	V
Maximum input frequency	FIN	AVDD = 5V, DACREF: AVDD/2 VIN = 3Vp-p, 10kHz VOUT[7:0] = 0xFF RL = 22kΩ, CL = 100pF	2.7	3.0		Vp-p
Output distortion	SINAD	AVDD = 5V, DACREF: AVDD/2 VIN = 3Vp-p, 1kHz VOUT[7:0]=0x0A to 0xFF RL = 22kΩ, CL = 100pF 30kHz LPF used *4)	56	60		dB



Parameter	Symbol	Condition	Min.	Typ.	Max.	Unit
DAC output settling time	$t_{LDD1}$	VOUT[7:0] = 0x10↔0xEF Until output reaches the half LSB of the final value. RS = 2.2kΩ, RL = 22kΩ, CL = 1000pF *3)			300	μs
VIN pin input impedance	$R_{IN}$			135		kΩ
VOUT pin output impedance	$R_{OUT}$			20		Ω

\*1) Error between the I/O curve and the ideal line connecting the output voltage for the 02 setting and the output voltage for the FF setting.

Unless otherwise specified, the following apply: AVDD = 2.6 to 3.3V, VSS = 0V, AVDD ≥ VIN, VREF = 0V to AVDD, Ta = -40°C to +85°C

DACREF shows an internal setting level of DAC reference voltage.

Parameter	Symbol	Condition	Min.	Typ.	Max.	Unit
Resolution	RES			8		bit
Differential nonlinearity	DNL	VIN = AVDD = 3V DACREF: VSS	-1		+1	LSB
Nonlinearity *2)	INL	IAO  = 0μA VOUT = 0x02 to 0xFF	-1.5		+1.5	LSB
Buffer amplifier output voltage range	VAO4	IAO  ≤ 600μA VIN = AVDD, DACREF: VSS VOUT[7:0] = 0x00			0.4	V
		IAO  ≤ 600μA VIN = AVDD, DACREF: VSS VOUT[7:0] = 0xFF	AVDD-0.4			V
Output distortion	DISTN	AVDD = 3V, DACREF: AVDD/2 VIN = 1.8Vp-p, 1kHz VOUT[7:0]=0x0A to 0xFF RL = 22kΩ, CL = 100pF 30kHz LPF used *4)	45	55		dB

\*2) Error between the I/O curve and the ideal line connecting the output voltage for the 02 setting and the output voltage for the FF setting.

- \*3) Load condition when AK2331 is used as DAC  
(Load condition when “DAC output settling time” is measured)

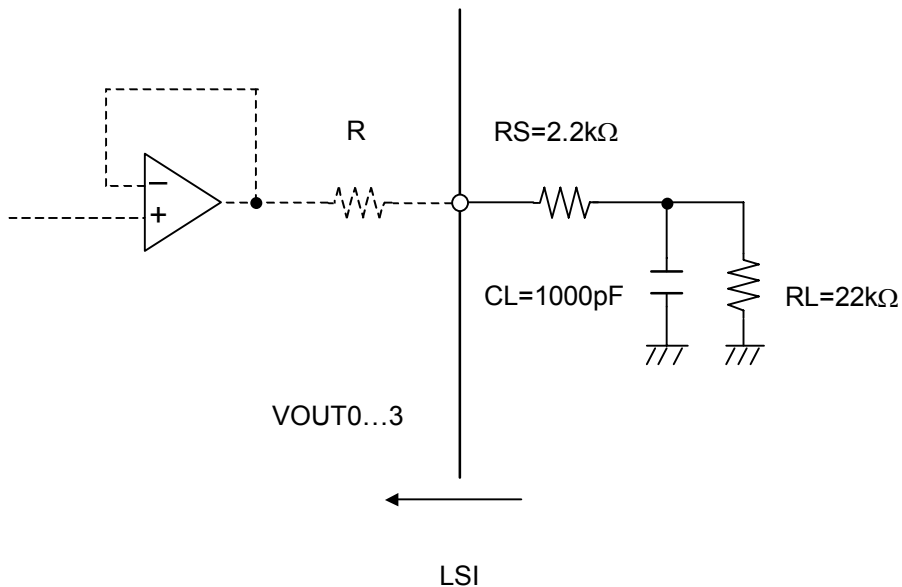

- \*4) Load condition when AK2331 is used as Attenuator  
(Load condition when “Output distortion” is measured)

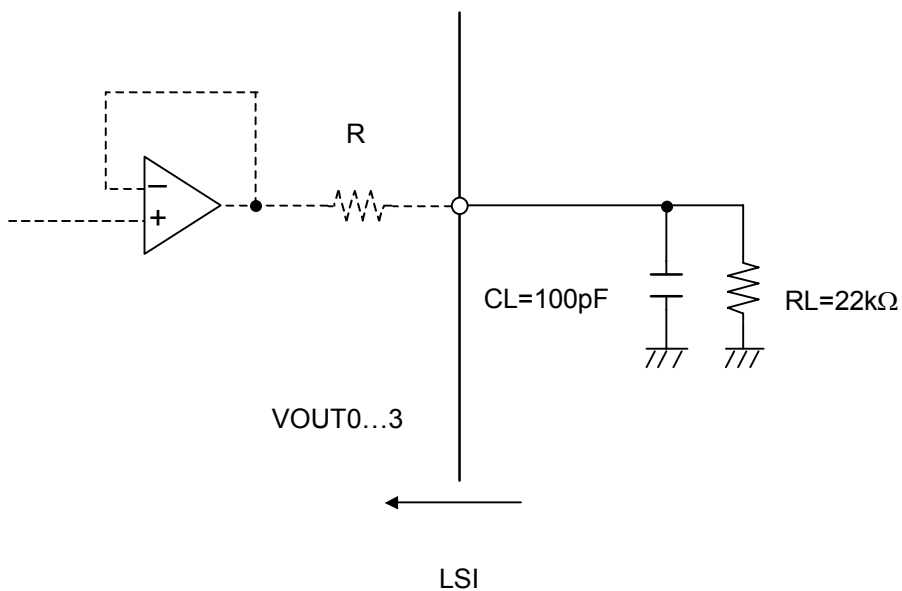

## Digital AC Timing

### Serial interface timing

The AK2331 writes data via the three-wire synchronous serial interface by means of CSN, SCLK, and SDATA.

SDATA (serial data) consists of a register address (starting from the MSB, A3 to A0) and control data (starting from the MSB, D7 to D0).

<1> CSN (chip select) is normally set to the high level.

When CSN is set to the low level, the serial interface becomes active.

<2> When a write operation is performed, an address and data are input in synchronization with the rising edges of 12 SCLK clock pulses while CSN is low.

<3> A write setting is made on the assumption that 12 clock pulses are input from SCLK while CSN is low.

Note that if clock pulses more than or less than 12 clock pulses are input, data cannot be set correctly.

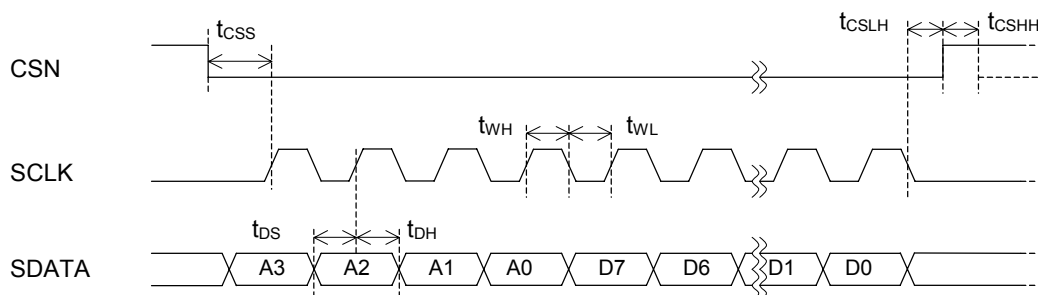

### Rising and falling times

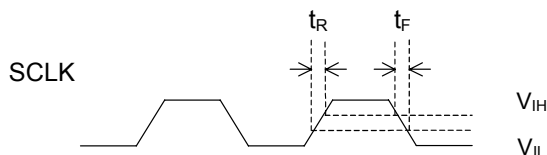

Parameter	Symbol	Condition	Min.	Typ.	Max.	Unit
CSN setup time	$t_{CSS}$		100			ns
SDATA setup time	$t_{DS}$		100			ns
SDATA hold time	$t_{DH}$		100			ns
SCLK high time	$t_{WH}$		500			ns
SCLK low time	$t_{WL}$		500			ns
CSN low hold time	$t_{CSLH}$		100			ns
CSN high hold time	$t_{CSHH}$		100			ns
DAC output setting time	$t_{LDD}$	VOUT[7:0]= 0x10↔0xEF Until output reaches the half LSB of the final value. RS=2.2kΩ, L=22kΩ, CL=1000pF			300	μs
SCLK rising time	$t_R$				100	ns
SCLK falling time	$t_F$				100	ns

Note Digital input timing measurements are made at 0.5DVDD for rising and falling edges.

## Register Functions

### 1) Register configuration

Address				Function	Data							
A3	A2	A1	A0		D7	D6	D5	D4	D3	D2	D1	D0
0	0	0	0	VOUT0 register	VOUT07	VOUT06	VOUT05	VOUT04	VOUT03	VOUT02	VOUT01	VOUT00
0	0	0	1	VOUT1 register	VOUT17	VOUT16	VOUT15	VOUT14	VOUT13	VOUT12	VOUT11	VOUT10
0	0	1	0	VOUT2 register	VOUT27	VOUT26	VOUT25	VOUT24	VOUT23	VOUT22	VOUT21	VOUT20
0	0	1	1	VOUT3 register	VOUT37	VOUT36	VOUT35	VOUT34	VOUT33	VOUT32	VOUT31	VOUT30
0	1	0	0	Not used	-	-	-	-	-	-	-	-
0	1	0	1	Not used	-	-	-	-	-	-	-	-
0	1	1	0	Not used	-	-	-	-	-	-	-	-
0	1	1	1	Not used	-	-	-	-	-	-	-	-
1	0	0	0	VREF register	DA3REF1	DA3REF0	DA2REF1	DA2REF0	DA1REF1	DA1REF0	DA0REF1	DA0REF0
1	0	0	1	Not used	-	-	-	-	-	-	-	-
1	0	1	0	AVDD/2 register	-	-	-	-	AVDD2O3	AVDD2O2	AVDD2O1	AVDD2O0
1	0	1	1	BUFON register	-	-	-	-	BUFON3	BUFON2	BUFON1	BUFON0
1	1	0	0	Software reset	SRST[7:0]							
1	1	0	1	VOUT0 to VOUT3 Output control	-	-	-	-	CTRL3	CTRL2	CTRL1	CTRL0
1	1	1	0	Not used	-	-	-	-	-	-	-	-
1	1	1	1	Not used	-	-	-	-	-	-	-	-

Note An access to data indicated by "-" does not have any effect on the LSI operation.

### 2) Descriptions of registers

#### 2.1) VOUT register

Address				Data							
A3	A2	A1	A0	D7	D6	D5	D4	D3	D2	D1	D0
0	0	0	0	VOUT07	VOUT06	VOUT05	VOUT04	VOUT03	VOUT02	VOUT01	VOUT00
↓	↓	↓	↓	↓	↓	↓	↓	↓	↓	↓	↓
0	0	1	1	VOUT37	VOUT36	VOUT35	VOUT34	VOUT33	VOUT32	VOUT31	VOUT30
Initial value				0	0	0	0	0	0	0	0

D7	D6	D5	D4	D3	D2	D1	D0	VOUT0 to VOUT3 output
0	0	0	0	0	0	0	0	$VOUT = (VIN - VREF) \cdot 0/256 + VREF$
0	0	0	0	0	0	0	1	$VOUT = (VIN - VREF) \cdot 1/256 + VREF$
0	0	0	0	0	0	1	0	$VOUT = (VIN - VREF) \cdot 2/256 + VREF$
0	0	0	0	0	0	1	1	$VOUT = (VIN - VREF) \cdot 3/256 + VREF$
↓	↓	↓	↓	↓	↓	↓	↓	↓
1	1	1	1	1	1	1	0	$VOUT = (VIN - VREF) \cdot 254/256 + VREF$
1	1	1	1	1	1	1	1	$VOUT = (VIN - VREF) \cdot 255/256 + VREF$

## 2.2) VREF registers

Address				Data							
A3	A2	A1	A0	D7	D6	D5	D4	D3	D2	D1	D0
1	0	0	0	DA3REF1	DA3REF0	DA2REF1	DA2REF0	DA1REF1	DA1REF0	DA0REF1	DA0REF0
Initial value				0	0	0	0	0	0	0	0

DA3REF1 to DA0REF1	DA3REF0 to DA0REF0	DAC reference voltage	Remarks
0	0	VSS (internal)	
0	1	AVDD (internal)	
1	0	AVDD/2 (internal)	
1	1	VREF (external)	

## 2.3) AVDD/2 register

Address				Data							
A3	A2	A1	A0	D7	D6	D5	D4	D3	D2	D1	D0
1	0	1	0	–	–	–	–	AVDD203	AVDD202	AVDD201	AVDD200
Initial value				0	0	0	0	0	0	0	0

Data	Item	Function		Remarks
		0	1	
AVDD203 to AVDD200	Internal AVDD/2 output	DAC output	Bypasses the DAC and outputs the AVDD/2 level through buffer.	

Note Internal generated AVDD/2 level can be output to VOUT0 to VOUT3 pins by setting this register.

## 2.4) BUFON register

Address				Data							
A3	A2	A1	A0	D7	D6	D5	D4	D3	D2	D1	D0
1	0	1	1	–	–	–	–	BUFON3	BUFON2	BUFON1	BUFON0
Initial value				0	0	0	0	0	0	0	0

Data	Item	Function		Remarks
		0	1	
BUFON3 to BUFON0	DAC buffer operation	Powers down buffer and outputs Hi-Z.	Buffer output	

## 2.5) Software reset register

Address				Data							
A3	A2	A1	A0	D7	D6	D5	D4	D3	D2	D1	D0
1	1	0	0	SRST[7:0]							
Initial value				0	0	0	0	0	0	0	0

When the SRST[7:0] register is set to 0xAA (10101010), a software reset is performed.

This setting initializes all registers.

Upon completion of a software reset, the register is set to 0.

## 2.6) VOUT0~VOUT3 Control register

Address				Data							
A3	A2	A1	A0	D7	D6	D5	D4	D3	D2	D1	D0
1	1	0	1	-	-	-	-	CTRL3	CTRL2	CTRL1	CTRL0
Initial Value				-	-	-	-	0	0	0	0

Data	Item	Function		Remarks
		0	1	
CTRL3 to CTRL0	VOUT0 to VOUT3 Output control	VOUT[7:0] data is output	VOUT[7:0] data is held	

Latch-timing of each DAC data can be matched by the **CTRL** register setting.

After **VOUT[7:0]** is set, when **CTRL** register is set to "0", **VOUT[7:0]** data is reflected in the DAC output immediately.

When **CTRL** register is set to "1", DAC output will not be affected regardless of changes made in **VOUT[7:0]** data. In this case VOUT[7:0] data output by DAC will remain the same as that of data when setting CTRL register to "1". The data will be reflected in the DAC output when the timing is set to "0".

## Recommended External Circuit Examples

### 1) Power supply stabilizing capacitors

Connect capacitors between the VDD and VSS pins to eliminate ripple and noise included in the power supply as shown below. For maximum effect, the capacitors should be placed at a shortest distance between the pins.

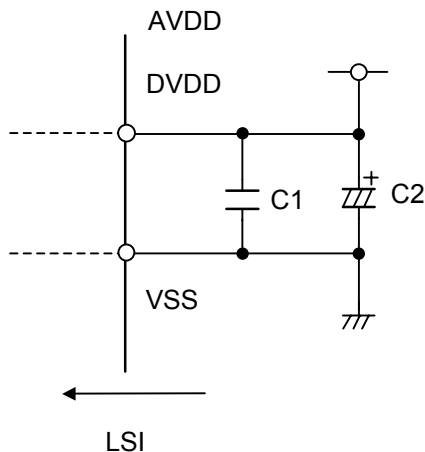

C1 = 0.1 $\mu$ F (Ceramic cap)

C2 = 4.7 $\mu$ F (Electrolytic cap)

### 2) External VIN0 to VIN3 capacitor

When inputting an analog signal to the VIN pin, connect a capacitor to adjust the DC offset of the input signal and the internal operation point in the LSI device. This forms a high-pass filter with  $f_c$  being about 130Hz.

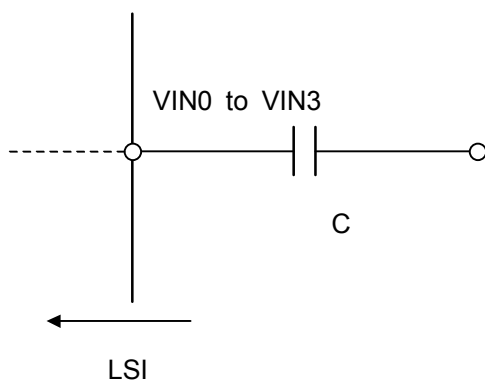

C = 0.01 $\mu$ F

# Package

## 1) Marking

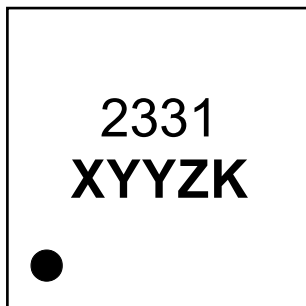

Part number	2331
Date code	X: Least significant digit of the year of production Y: Week of production Z: Identification code of production lot K: Consignment code

## 2) External dimensions

Package type: 16-pin QFNJ (3.0mm x 3.0mm x 0.70mm, 0.5-mm pitch)

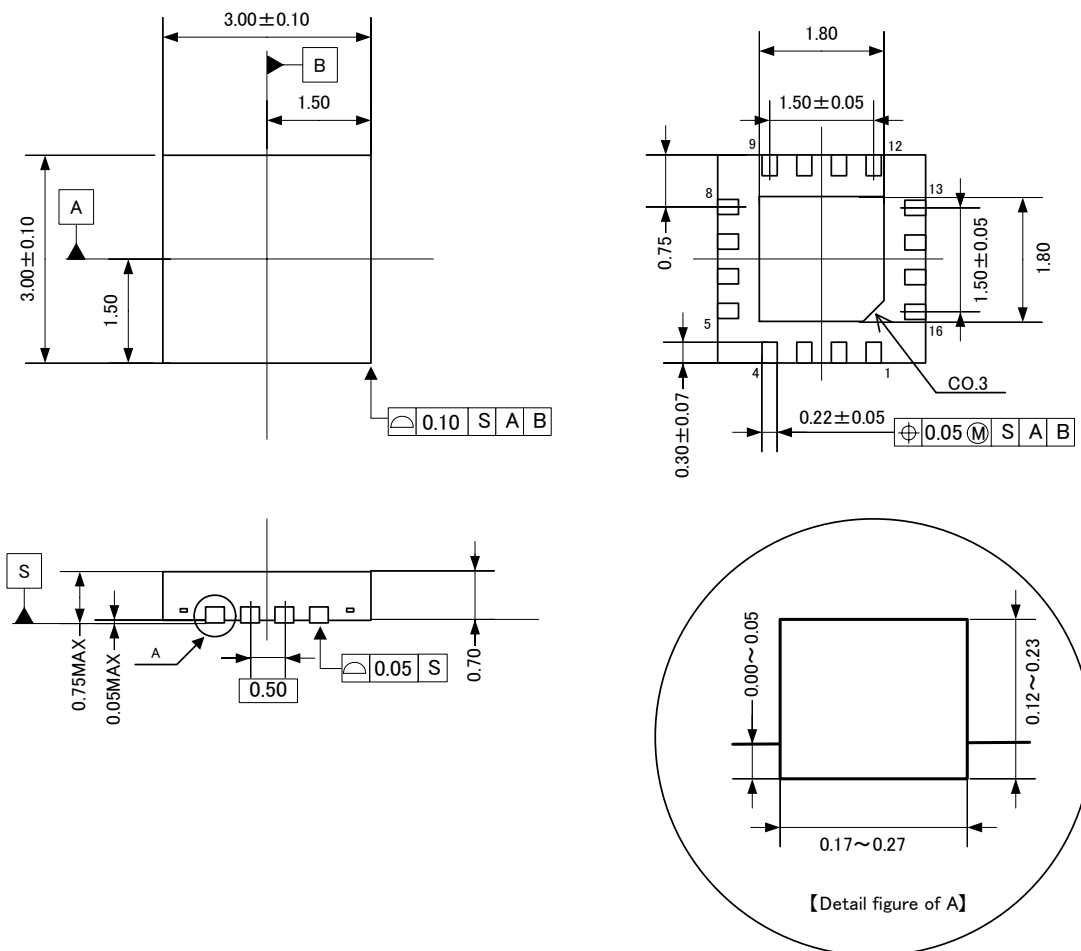

**Note** The exposed pad at the center of the back of the package must be connected to VSS or opened.



## Important Notice

### IMPORTANT NOTICE

- These products and their specifications are subject to change without notice. When you consider any use or application of these products, please make inquiries the sales office of Asahi Kasei EMD Corporation (AKEMD) or authorized distributors as to current status of the products.
- AKEMD assumes no liability for infringement of any patent, intellectual property, or other rights in the application or use of any information contained herein.
- Any export of these products, or devices or systems containing them, may require an export license or other official approval under the law and regulations of the country of export pertaining to customs and tariffs, currency exchange, or strategic materials.
- AKEMD products are neither intended nor authorized for use as critical components<sup>Note1)</sup> in any safety, life support, or other hazard related device or system<sup>Note2)</sup>, and AKEMD assumes no responsibility for such use, except for the use approved with the express written consent by Representative Director of AKEMD. As used here:
  - Note1) A critical component is one whose failure to function or perform may reasonably be expected to result, whether directly or indirectly, in the loss of the safety or effectiveness of the device or system containing it, and which must therefore meet very high standards of performance and reliability.
  - Note2) A hazard related device or system is one designed or intended for life support or maintenance of safety or for applications in medicine, aerospace, nuclear energy, or other fields, in which its failure to function or perform may reasonably be expected to result in loss of life or in significant injury or damage to person or property.
- It is the responsibility of the buyer or distributor of AKEMD products, who distributes, disposes of, or otherwise places the product with a third party, to notify such third party in advance of the above content and conditions, and the buyer or distributor agrees to assume any and all responsibility and liability for and hold AKEMD harmless from any and all claims arising from the use of said product in the absence of such notification.