

DATA SHEET

SKY73010: 300 – 2500 MHz Direct Quadrature Modulator

Applications

- QPSK/GMSK/QAM/DQPSK modulators
- Single-sideband modulators
- Image reject mixers
- CDMA base stations
- GSM/EDGE, TDMA/TDMA-EDGE, and Trans-European Trunked Radio (TETRA) base stations
- First upconverter in dual conversion receivers

Features

- Broad RF and LO frequency range: 300 to 2500 MHz
- Carrier suppression greater than 35 dBc
- Sideband suppression greater than 45 dBc
- Modulation bandwidth DC to 250 MHz
- Noise floor less than -153 dBm/Hz
- Broadband LO/RF flatness
- RFLGA™ (16-pin, 4 x 4 mm) Pb-free package (MSL3, 260 °C per JEDEC J-STD-020)

Description

The SKY73010 is an integrated quadrature modulator for direct modulation of high frequency Amplitude Modulated (AM), Phase Modulated (PM), or compound carriers. A SiGe Bipolar Complementary Metal Oxide Semiconductor (BiCMOS) process is used to offer excellent linearity, noise floor, and carrier suppression performance.

The device package and pinout for the 16-pin RF Land Grid Array (RFLGA) are shown in Figure 1. Figure 2 shows a functional block diagram for the SKY73010. Signal pin assignments and functional pin descriptions are provided in Table 1.



Skyworks offers lead (Pb)-free, RoHS (Restriction of Hazardous Substances) compliant packaging.

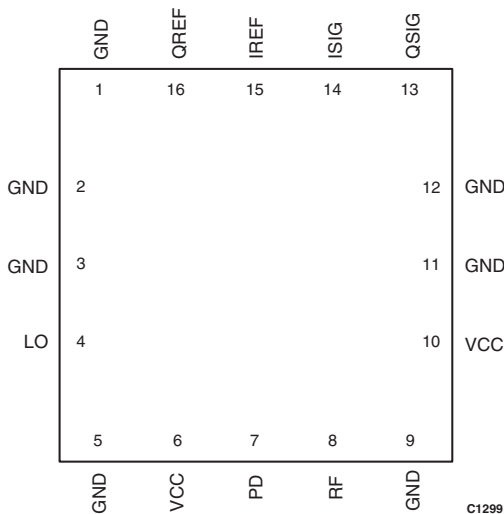

Figure 1. SKY73010 Pinout– 16-Pin RFLGA Package (Top View)

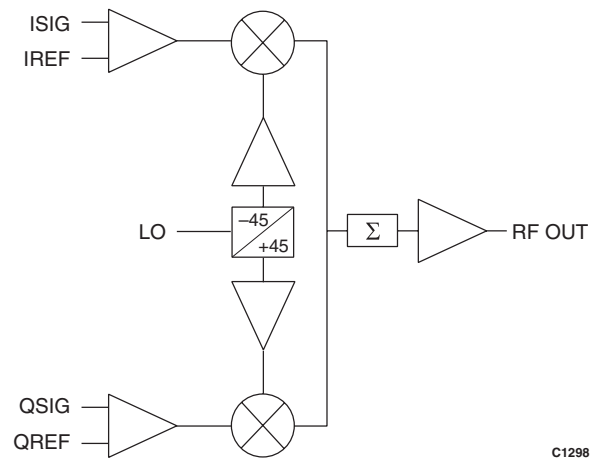

Figure 2. SKY73010 Functional Block Diagram

Table 1. SKY73010 Signal Descriptions

Pin #	Name	Description	Pin #	Name	Description
1	GND	Ground	9	GND	Ground
2	GND	Ground	10	VCC	+5 VDC supply
3	GND	Ground	11	GND	Ground
4	LO	LO input	12	GND	Ground
5	GND	Ground	13	QSIG	Q input
6	VCC	+5 VDC supply	14	ISIG	I input
7	PD	Power down	15	IREF	I reference
8	RF	Ground	16	QREF	Q reference

Circuit Design Considerations

The following design considerations are general in nature and must be followed regardless of final use or configuration.

1. Paths to ground should be made as short as possible.
2. The downset paddle of the SKY73010 direct quadrature modulator has special electrical and thermal grounding requirements. This pad is the main thermal conduit for heat dissipation. Since the circuit board acts as the heat sink, it must shunt as much heat as possible from the device. As such, design the connection to the ground pad to dissipate the maximum wattage produced to the circuit board. Multiple vias to the grounding layer are required.
3. Two external output bypass capacitors are required on the VCC pin. The values of these capacitors change with respect to the desired RF frequency. One capacitor should be used for low frequency bypassing and the other capacitor for high frequency bypassing. Special attention should be given so that the smaller value capacitor does not go into self-resonance at the desired RF frequency.

Testing Procedure

The following In-Phase and Quadrature (I/Q) input settings were used to measure the CDMA Adjacent Channel Power Reduction (ACPR):

- Pilot Channel Active
- Sync Channel Active
- Paging Channel Active
- Six Traffic Channels Active
- 32x oversampling
- Equifilter

Package and Handling Information

Since the device package is sensitive to moisture absorption, it is baked and vacuum packed before shipping. Instructions on the shipping container label regarding exposure to moisture after the container seal is broken must be followed. Otherwise, problems related to moisture absorption may occur when the part is subjected to high temperature during solder assembly.

The SKY73010 is rated to Moisture Sensitivity Level 3 (MSL3) at 260 °C. It can be used for lead or lead-free soldering. For additional information, refer to the Skyworks Application Note, *PCB Design & SMT Assembly/Rework Guidelines for RFLGA Packages*, document number 103147.

Care must be taken when attaching this product, whether it is done manually or in a production solder reflow environment. Production quantities of this product are shipped in a standard tape and reel format. For packaging details, refer to the Skyworks Application Note, *Tape and Reel*, document number 101568.

Electrical and Mechanical Specifications

The absolute maximum ratings of the SKY73010 are provided in Table 2. The recommended operating conditions are specified in Table 3 and electrical specifications are provided in Table 4.

Typical performance characteristics are shown in Figures 3 through 7. Figure 8 provides a typical evaluation board schematic. Package dimensions for the 16-pin RFLGA are shown in Figure 9, and tape and reel dimensions are shown in Figure 10.

Electrostatic Discharge (ESD) Sensitivity

The SKY73010 is a static-sensitive electronic device. Do not operate or store near strong electrostatic fields. Take proper ESD precautions.

Table 2. SKY73010 Absolute Maximum Ratings
(T_A = +25 °C, unless otherwise noted)

Parameter	Symbol	Min	Typical	Max	Units
+3 V supply voltage	VCC	4.5		6.0	V
Power dissipation	P _{DIS}			750	mW
LO input power	P _{LOIN}		0	+6	dBm
IF input voltage				1.5	V _{pp}
Thermal resistance	R _{TH}		44		°C/W
Operating case temperature	T _{OPR}	-40		+85	°C
Storage case temperature	T _{STG}	-40		+150	°C

Note: Exposure to maximum rating conditions for extended periods may reduce device reliability. There is no damage to device with only one parameter set at the limit and all other parameters set at or below their nominal values.

Table 3. SKY73010 Recommended Operating Conditions

Parameter	Symbol	Min	Typical	Max	Units
+5 V supply voltage	VCC	4.5	5.0	5.5	V
Current consumption	I _{CC}		90	110	mA
Operating case temperature	T _{OPR}	-40		+85	°C

Table 4. SKY73010 Electrical Characteristics (1 of 2)
(VCC = 5 V, IF = 2 MHz, LO input power = -3 dBm, T_c = 25 °C, unless otherwise noted)

Parameter	Symbol	Test Conditions	Min	Typical	Max	Units
Local Oscillator						
Input frequency range			300		2500	MHz
Input power level			-3		+3	dBm
Input impedance				2.0:1		VSWR
I/Q Signal Reference Input						
Input frequency range			DC		250	MHz
Reference voltage			3.6	4.1		V
RF Output (400 MHz)						
Output -1 dB compression point				3		dBm
CDMA output channel power				-12		dBm
CDMA ACPR		CDMA RF output power = -12 dBm		73		dBc
Optimized carrier suppression		Optimized I/Q DC offsets	50			dBc
Carrier suppression			28	35		dBc
Sideband suppression			30	35		dBc
Optimized sideband suppression		Optimized I/Q phase and amplitude balance	50			dBc
Broadband noise floor		@ 20 MHz offset from carrier		-152	-150	dBm/Hz
Output impedance				2.0:1		Ω

Table 4. SKY73010 Electrical Characteristics (2 of 2)
(VCC = 5 V, IF = 2 MHz, LO input power = -3 dBm, Tc = 25 °C, unless otherwise noted)

Parameter	Symbol	Test Conditions	Min	Typical	Max	Units
RF Output (900 MHz)						
Output -1 dB compression point			-1.5	+1.5		dBm
CDMA output channel power				-12		dBm
CDMA ACPR		CDMA RF output power = -12 dBm		72		dBc
Optimized carrier suppression		Optimized I/Q DC offsets	50			dBc
Carrier suppression			24	35		dBc
Sideband suppression			32	45		dBc
Optimized sideband suppression		Optimized I/Q phase and amplitude balance	50			dBc
Broadband noise floor		@ 20 MHz offset from carrier		-153	-150	dBm/Hz
Output impedance				2.0:1		Ω
RF Output (1900 MHz)						
Output -1 dB compression point			-6.0	-3.5		dBm
CDMA output channel power				-18		dBm
CDMA ACPR		CDMA RF output power = -18 dBm		70		dBc
Optimized carrier suppression		Optimized I/Q DC offsets		50		dBc
Carrier suppression			20	28		dBc
Sideband suppression			28	40		dBc
Optimized sideband suppression		Optimized I/Q phase and amplitude balance		50		dBc
Broadband noise floor		@ 20 MHz offset from carrier		-155	-152	dBm/Hz
Output impedance				2.0:1		Ω

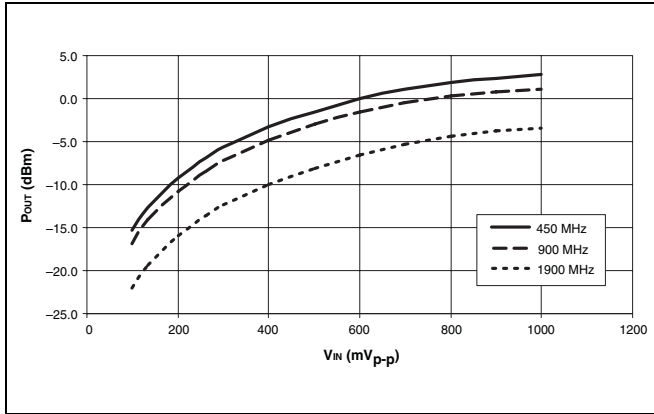

Figure 3. Continuous Wave (CW) Intermediate Frequency (IF) Input Voltage vs Output Power

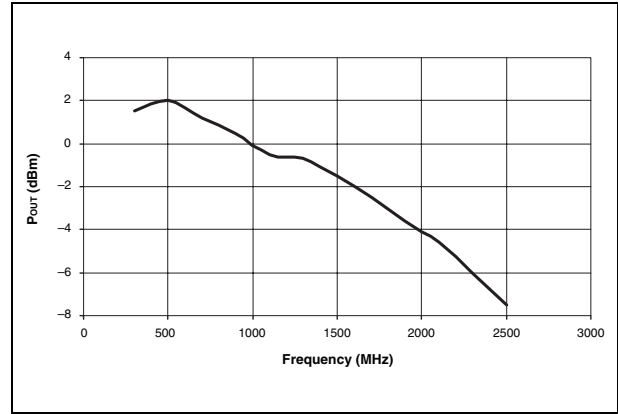

Figure 4. Output 1 dB Compression Points vs RF Frequency

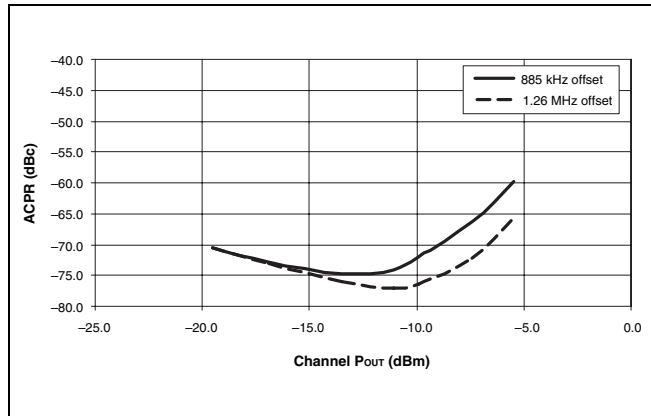

Figure 5. 450 MHz CDMA ACPR vs Channel Output Power

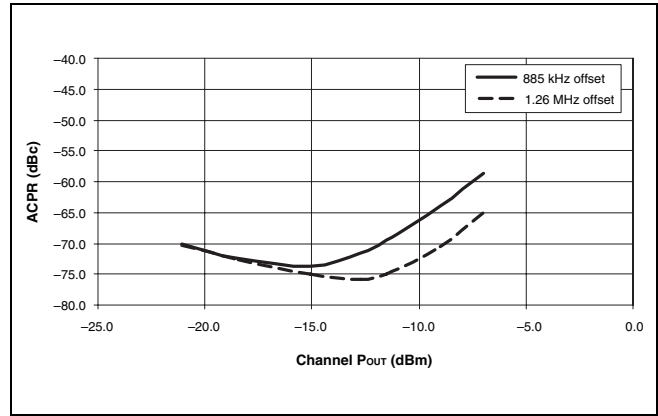

Figure 6. 900 MHz CDMA ACPR vs Channel Output Power

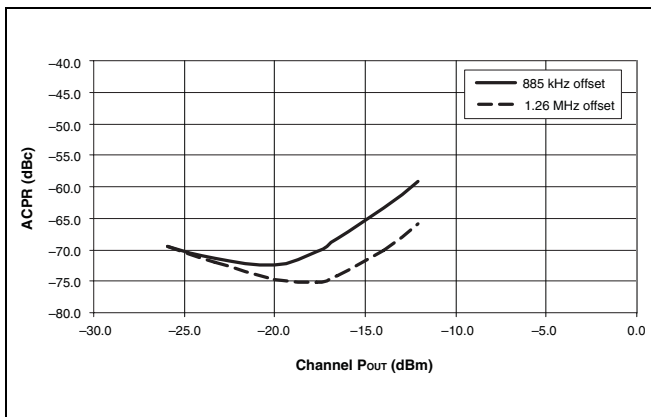

Figure 7. 1900 MHz CDMA ACPR vs Channel Output Power

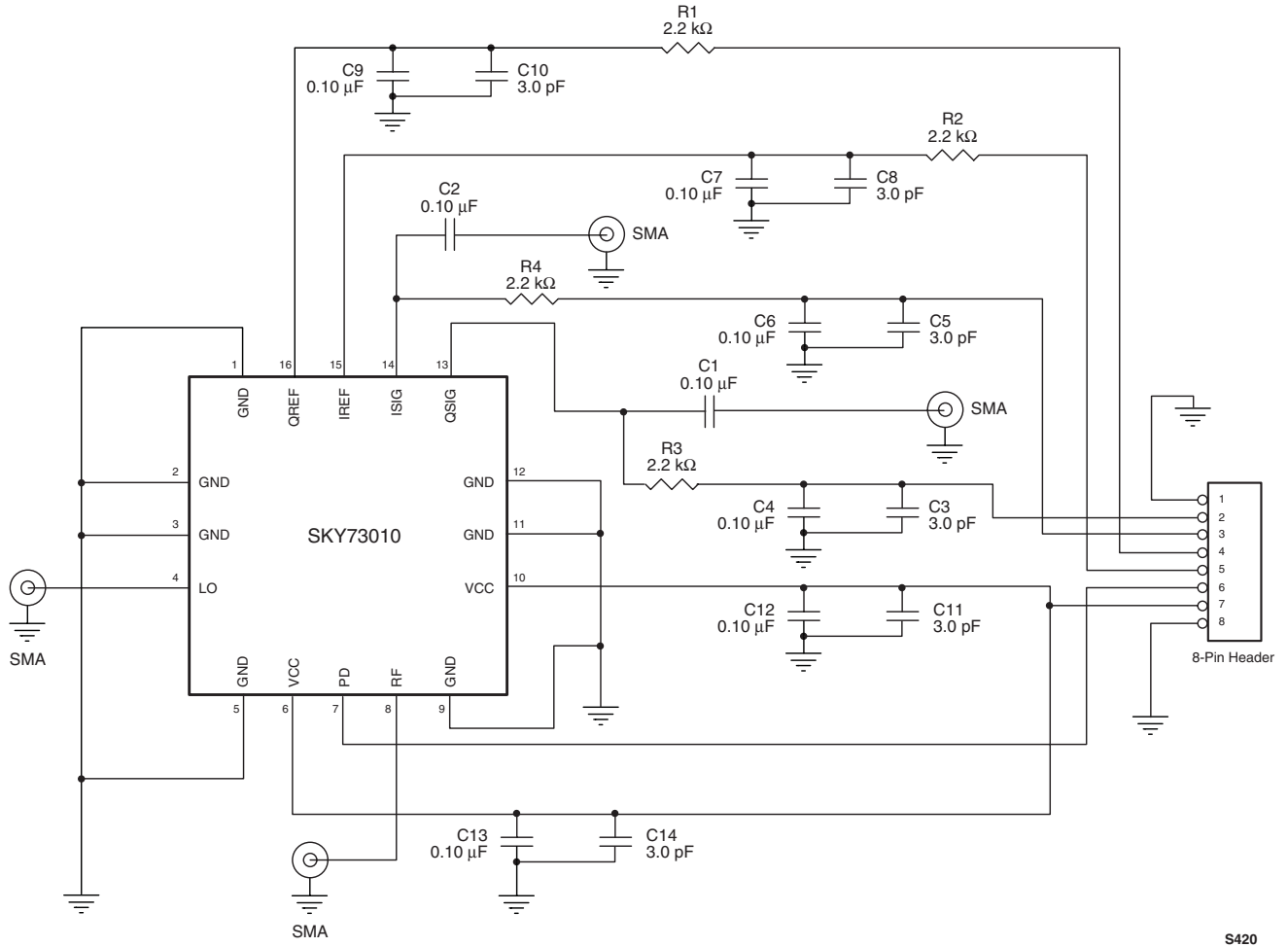

Figure 8. SKY73010 Evaluation Board Schematic

S420

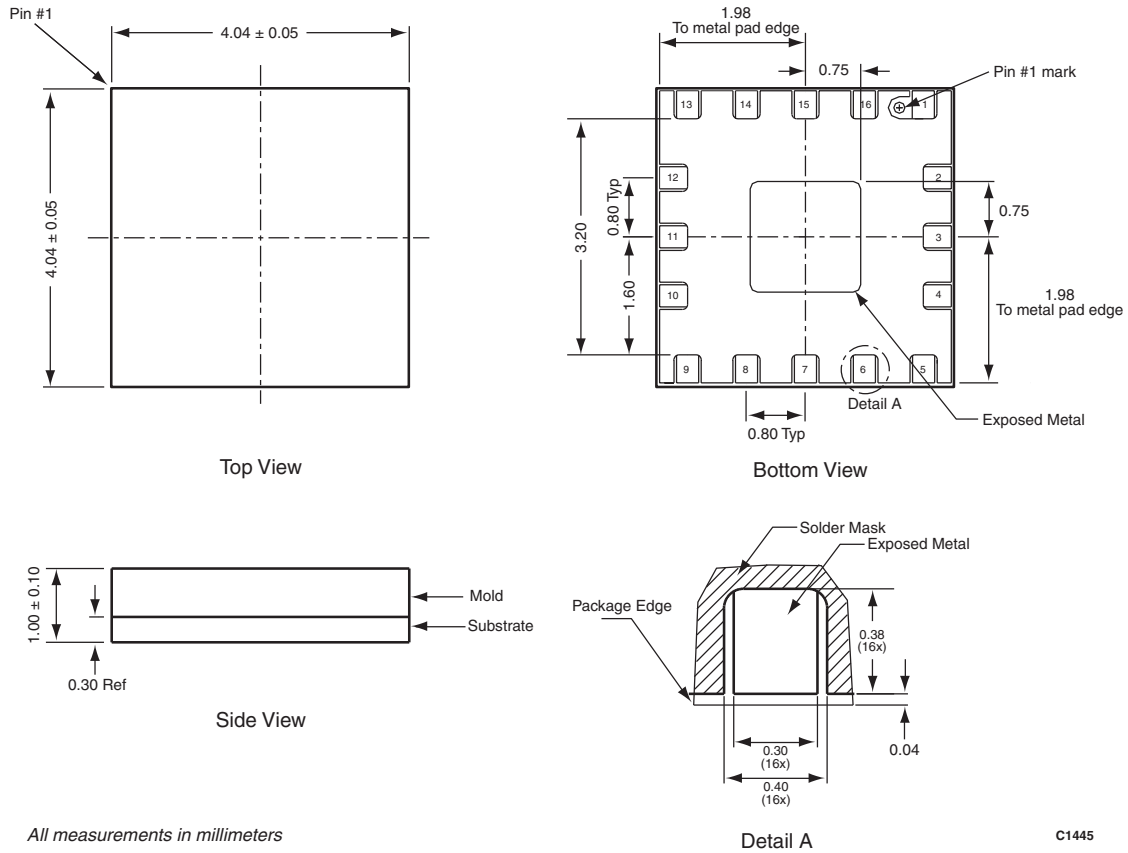

Figure 9. SKY73010 16-Pin RFLGA Package Dimensions

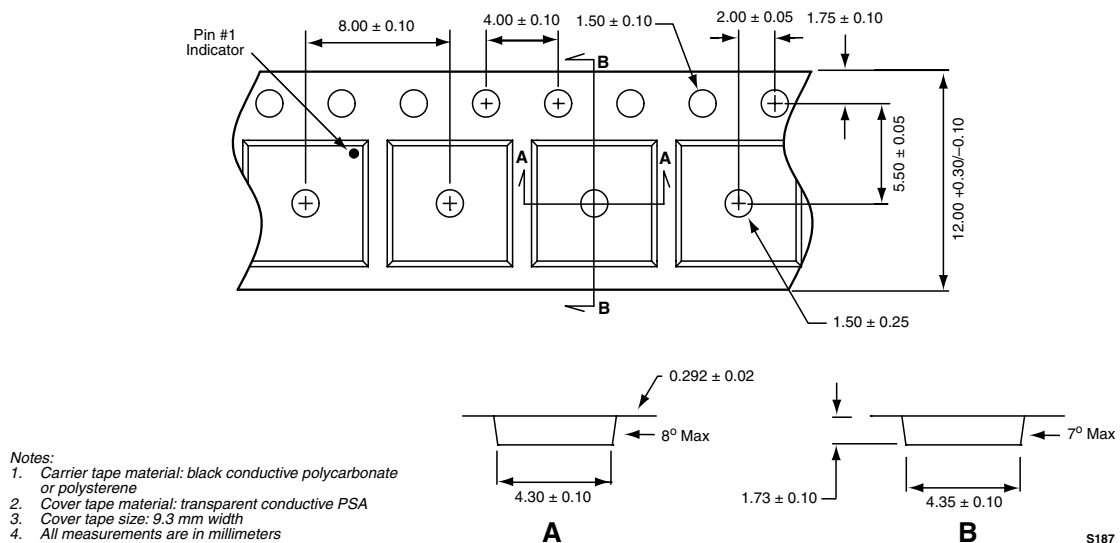

Figure 10. SKY73010 16-Pin RFLGA Tape and Reel Dimensions

Ordering Information

Model Name	Manufacturing Part Number	Evaluation Kit Part Number
SKY73010 300-2500 MHz Direct Quadrature Modulator	SKY73010-21	TW12-D692

Copyright © 2003, 2004, 2006 Skyworks Solutions, Inc. All Rights Reserved.

Information in this document is provided in connection with Skyworks Solutions, Inc. (“Skyworks”) products or services. These materials, including the information contained herein, are provided by Skyworks as a service to its customers and may be used for informational purposes only by the customer. Skyworks assumes no responsibility for errors or omissions in these materials or the information contained herein. Skyworks may change its documentation, products, services, specifications or product descriptions at any time, without notice. Skyworks makes no commitment to update the materials or information and shall have no responsibility whatsoever for conflicts, incompatibilities, or other difficulties arising from any future changes.

No license, whether express, implied, by estoppel or otherwise, is granted to any intellectual property rights by this document. Skyworks assumes no liability for any materials, products or information provided hereunder, including the sale, distribution, reproduction or use of Skyworks products, information or materials, except as may be provided in Skyworks Terms and Conditions of Sale.

THE MATERIALS, PRODUCTS AND INFORMATION ARE PROVIDED “AS IS” WITHOUT WARRANTY OF ANY KIND, WHETHER EXPRESS, IMPLIED, STATUTORY, OR OTHERWISE, INCLUDING FITNESS FOR A PARTICULAR PURPOSE OR USE, MERCHANTABILITY, PERFORMANCE, QUALITY OR NON-INFRINGEMENT OF ANY INTELLECTUAL PROPERTY RIGHT; ALL SUCH WARRANTIES ARE HEREBY EXPRESSLY DISCLAIMED. SKYWORKS DOES NOT WARRANT THE ACCURACY OR COMPLETENESS OF THE INFORMATION, TEXT, GRAPHICS OR OTHER ITEMS CONTAINED WITHIN THESE MATERIALS. SKYWORKS SHALL NOT BE LIABLE FOR ANY DAMAGES, INCLUDING BUT NOT LIMITED TO ANY SPECIAL, INDIRECT, INCIDENTAL, STATUTORY, OR CONSEQUENTIAL DAMAGES, INCLUDING WITHOUT LIMITATION, LOST REVENUES OR LOST PROFITS THAT MAY RESULT FROM THE USE OF THE MATERIALS OR INFORMATION, WHETHER OR NOT THE RECIPIENT OF MATERIALS HAS BEEN ADVISED OF THE POSSIBILITY OF SUCH DAMAGE.

Skyworks products are not intended for use in medical, lifesaving or life-sustaining applications, or other equipment in which the failure of the Skyworks products could lead to personal injury, death, physical or environmental damage. Skyworks customers using or selling Skyworks products for use in such applications do so at their own risk and agree to fully indemnify Skyworks for any damages resulting from such improper use or sale.

Customers are responsible for their products and applications using Skyworks products, which may deviate from published specifications as a result of design defects, errors, or operation of products outside of published parameters or design specifications. Customers should include design and operating safeguards to minimize these and other risks. Skyworks assumes no liability for applications assistance, customer product design, or damage to any equipment resulting from the use of Skyworks products outside of stated published specifications or parameters.

Skyworks, the Skyworks symbol, and “Breakthrough Simplicity” are trademarks or registered trademarks of Skyworks Solutions, Inc., in the United States and other countries. Third-party brands and names are for identification purposes only, and are the property of their respective owners. Additional information, including relevant terms and conditions, posted at www.skyworksinc.com, are incorporated by reference.