

# SKY65174-21: 2.4 – 2.5 GHz WLAN Power Amplifier Module

## Applications

- IEEE 802.11 b/g/n WLAN systems
- ISM band transmitters
- Wireless access points, routers, gateways

## Features

- PA linear output power: +27 dBm @ <2.5% EVM
- High gain: 35 dB
- Input/Output internally matched to 50 Ω
- Internal, active bias circuits
- MCM (10-pin, 4 x 4 mm) package (MSL3, 260 °C per JEDEC J-STD-020)



Skyworks Pb-free products are compliant with all applicable legislation. For additional information, refer to *Skyworks Definition of Lead (Pb)-Free*, document number SQ04-0073.

## Description

The SKY65174-21 is a highly integrated Power Amplifier Module (PAM) intended for high performance Wireless Local Area Network (WLAN) requiring up to +27 dBm linear output power.

The SKY65174-21 is fabricated using Skyworks high reliability Heterojunction Bipolar Transistor (HBT) InGaP process, which allows for single supply operation while maintaining high efficiency and good linearity.

The PAM is packaged in a 10-pin, 4 x 4 mm Multi-Chip Module (MCM) together with power detector, biasing, and input/output matching components. This architecture makes the SKY65174-21 a highly integrated solution requiring a minimum number of external components.

A functional block diagram of the SKY65174-21 is shown in Figure 1. The 10-pin MCM package and pinout are provided in Figure 2. Signal pin assignments and functional pin descriptions are provided in Table 1.

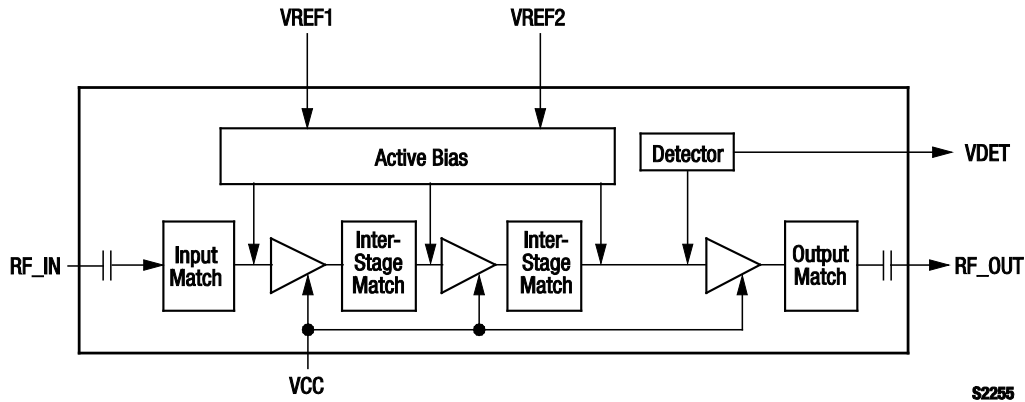

Figure 1. SKY65174-21 PAM Block Diagram

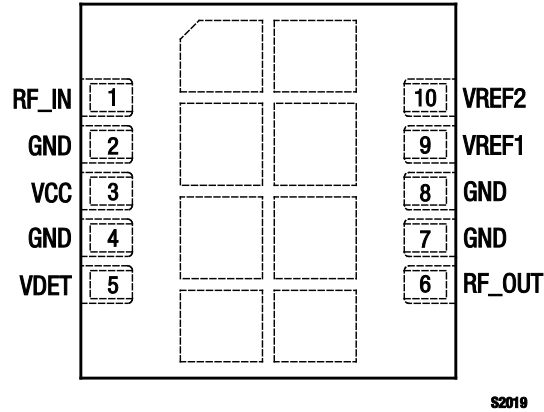

Figure 2. SKY65174-21 Pinout – 10-Pin MCM (Top View)

Table 1. SKY65174-21 Signal Descriptions

Pin #	Name	Description	I/O	Signal Type
1	RF_IN	RF transmitter input	I	RF
2	GND	Ground	–	–
3	VCC	Supply voltage	I	Supply 5 V
4	GND	Ground	–	–
5	VDET	Power detector output	O	Analog
6	RF_OUT	RF transmitter output	O	RF
7	GND	Ground	–	–
8	GND	Ground	–	–
9	VREF1	Reference voltage 1	I	2.85 V
10	VREF2	Reference voltage 2	I	2.85 V

### Technical Description

The SKY65174-21 meets the stringent WLAN spectral masks for Orthogonal Frequency Division Multiplexing (OFDM) composite signals. The high linearity of the PA enables an Error Vector Magnitude (EVM) of less than three percent at output power levels of +27 dBm.

The power detector achieves a dynamic range greater than 25 dB. The PAM is stable up to an 6:1 Voltage Standing-Wave Ratio (VSWR).

The SKY65174-21 PAM supports a battery voltage range of 3.3 V up to 5.5 V.

### Electrical and Mechanical Specifications

The absolute maximum ratings of the SKY65174-21 are provided in Table 2. The recommended operating conditions are specified in Table 3 and electrical specifications are provided in Tables 4 (V<sub>CC</sub> = 5 V) and 5 (V<sub>CC</sub> = 3.3 V).

Typical performance characteristics of the SKY65174-21 are illustrated in Figures 3 to 8.

**Table 2. SKY65174-21 Absolute Maximum Ratings (Note 1)**

Parameter	Symbol	Minimum	Maximum	Units
RF output power (CW)	P <sub>OUT</sub>		+30	dBm
Supply voltage	V <sub>CC</sub>		5.5	V
Reference voltages (Note 2)	VREF1, VREF2		3.1	V
Total supply current	I <sub>CC</sub>		1000	mA
Power dissipation	P <sub>D</sub>		2.9	W
Thermal resistance	Θ <sub>JC</sub>		28	°C/W
Storage temperature	T <sub>STG</sub>	-55	+125	°C
Operating temperature	T <sub>A</sub>	-40	+85	°C
Junction temperature	T <sub>J</sub>		+150	°C

**Note 1:** Exposure to maximum rating conditions for extended periods may reduce device reliability. There is no damage to device with only one parameter set at the limit and all other parameters set at or below their nominal value. Exceeding any of the limits listed here may result in permanent damage to the device.

**Note 2:** Measured at the package pins.

**CAUTION:** Although this device is designed to be as robust as possible, Electrostatic Discharge (ESD) can damage this device. This device must be protected at all times from ESD. Static charges may easily produce potentials of several kilovolts on the human body or equipment, which can discharge without detection. Industry-standard ESD precautions should be used at all times.

**Table 3. SKY65174-21 Recommended Operating Conditions**

Parameter	Symbol	Minimum	Typical	Maximum	Units
Operating frequency	f	2412		2483	MHz
Supply voltage (high voltage mode)	V <sub>CC</sub>	4.5	5.0	5.5	V
Supply voltage (low voltage mode)	V <sub>CC</sub>	3.0	3.3	3.6	V
RF output power	P <sub>OUT</sub>		+27		dBm
Reference voltages (Note 1)	VREF1, VREF2	2.75	2.85	2.95	V
Reference current 1	I <sub>REF1</sub>		11	12	mA
Reference current 2	I <sub>REF2</sub>		1	2	mA
Total supply current (CW signal)	I <sub>CC</sub>		600		mA
Operating temperature	T <sub>A</sub>	-35	+25	+85	°C

**Note 1:** Measured at the package pins.

**Table 4. SKY65174-21 Electrical Specifications (Note 1)**  
**(V<sub>CC</sub> = +5 V, VREF1 = VREF2 = 3.1 V, T<sub>A</sub> = +25 °C, f = 2.442 GHz, CW, Unless Otherwise Noted)**

Parameter	Symbol	Test Condition	Min	Typical	Max	Units
<b>Continuous Wave (CW) Input</b>						
Quiescent current	I <sub>CO</sub>			275	300	mA
Operational current	I <sub>CC</sub>	P <sub>OUT</sub> = +27 dBm		700	800	mA
1 dB output compression point	OP1dB		+31.0	+34.5		dBm
Noise Figure	NF			7		dB
Small signal gain	IS21I		34.0	34.5	35.0	dB
Gain variation	ΔS21	P <sub>IN</sub> = -25 dBm, f = 2.4 to 2.5 GHz			1	dB
Input return loss	IS11I		15			dB
Detector voltage	V <sub>DET</sub>	802.11g, P <sub>OUT</sub> = +27 dBm		0.75	0.80	V
2 <sup>nd</sup> harmonic distortion	2fo	P <sub>OUT</sub> = +27 dBm			-50	dBc
3 <sup>rd</sup> harmonic distortion	3fo	P <sub>OUT</sub> = +27 dBm			-60	dBc
PA enable time		VREF1 toggled, VREF2 = 2.85 V		200		ns
<b>IEEE 802.11g OFDM Input Signal, 64 QAM, 54 Mbps</b>						
Output power	P <sub>OUT</sub>	EVM = 2.5% EVM = 3.0%		- +27	+27 -	dBm dBm

Note 1: Performance is guaranteed only under the conditions listed in this Table.

**Table 5. SKY65174-21 Electrical Specifications (Note 1)**  
**(V<sub>CC</sub> = +3.3 V, VREF1 = VREF2 = 2.85 V, T<sub>A</sub> = +25 °C, f = 2.442 GHz, CW, Unless Otherwise Noted)**

Parameter	Symbol	Test Condition	Min	Typical	Max	Units
<b>Continuous Wave (CW) Input</b>						
Quiescent current	I <sub>CO</sub>			230		mA
Operational current	I <sub>CC</sub>	P <sub>OUT</sub> = +24 dBm		520		mA
1 dB output compression point	OP1dB			+31		dBm
Small signal gain	IS21I			33		dB
<b>IEEE 802.11g OFDM Input Signal, 64 QAM, 54 Mbps</b>						
Output power	P <sub>OUT</sub>	EVM = 2.5%		+24		dBm

Note 1: Performance is guaranteed only under the conditions listed in this Table.

### Typical Performance Characteristics

( $V_{CC} = +5\text{ V}$ ,  $V_{REF1} = V_{REF2} = 3.1\text{ V}$ ,  $T_A = +25\text{ }^\circ\text{C}$ ,  $f = 2.442\text{ GHz}$ , Unless Otherwise Noted)

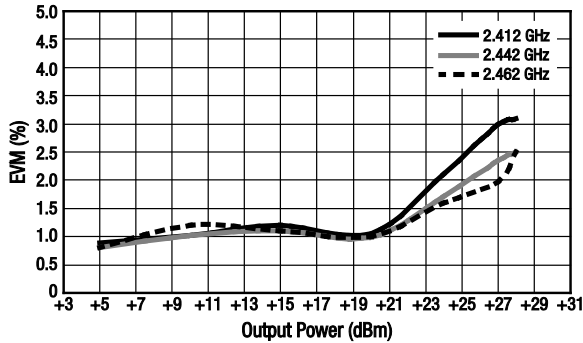

**Figure 3. EVM vs Output Power Over Frequency (64 QAM, 54 Mbps, OFDM)**

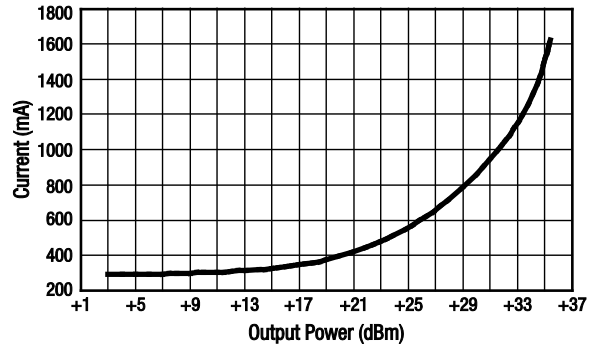

**Figure 4. Current vs Output Power (CW)**

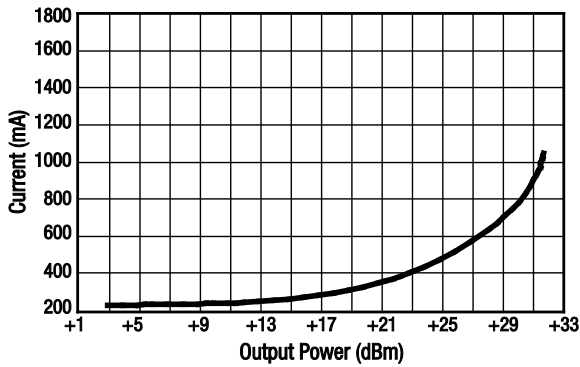

**Figure 5. Current vs Output Power (CW,  $V_{CC} = 3.3\text{ V}$ )**

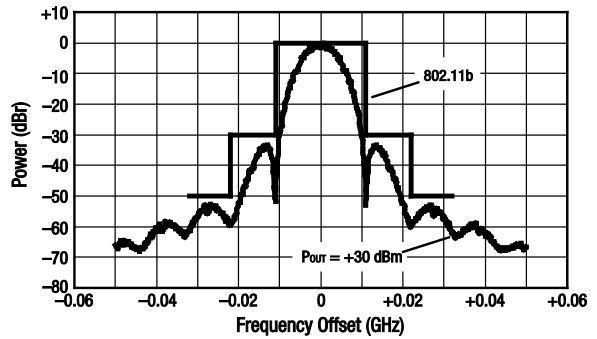

**Figure 6. Spectral Mask (11 Mbps)**

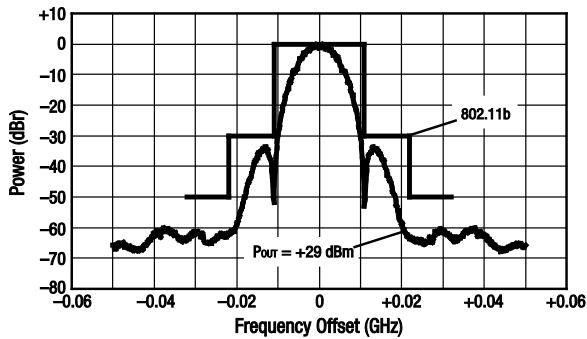

**Figure 7. Spectral Mask (11 Mbps,  $V_{CC} = 3.3\text{ V}$ )**

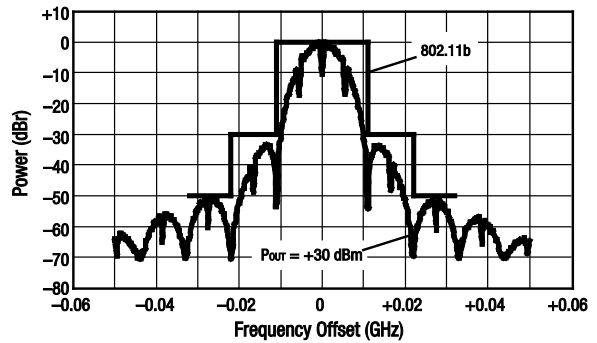

**Figure 8. Spectral Mask (1 Mbps)**

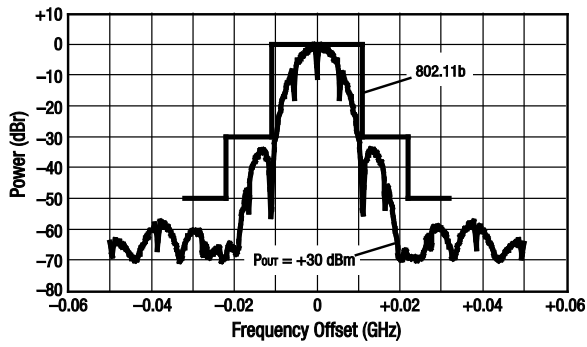

**Figure 9. Spectral Mask**  
(1 Mbps, Vcc = 3.3 V)

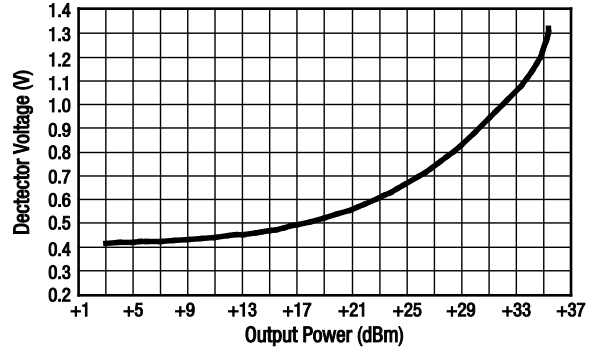

**Figure 10. Detector Voltage vs Output Power**  
(CW)

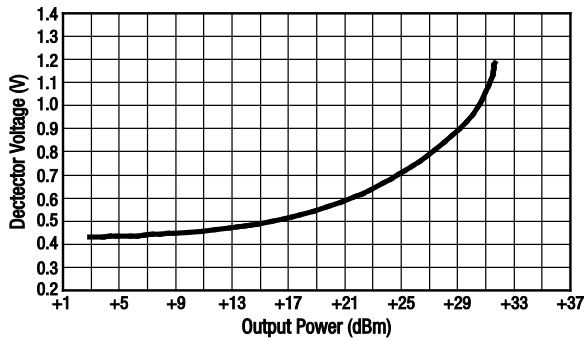

**Figure 11. Detector Voltage vs Output Power**  
(CW, Vcc = 3.3 V)

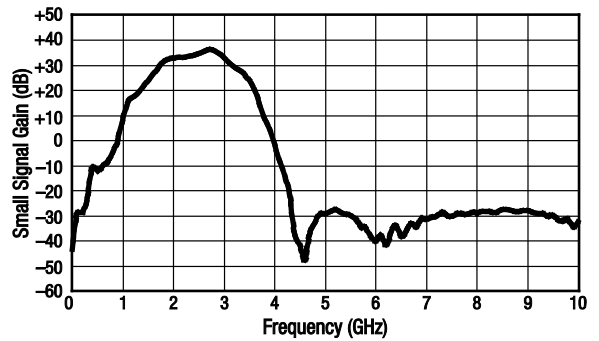

**Figure 12. Small Signal Gain vs Frequency**

## Evaluation Board Description

The SKY65174-21 Evaluation Board is used to test the performance of the SKY65174-21 PAM. Application schematic diagrams are provided in Figures 13 (for applications using phase and amplitude tracking) and 14 (for applications that do not use amplitude tracking). An assembly drawing for the Evaluation Board is shown in Figure 15.

## Circuit Design Configurations

The following design considerations are general in nature and must be followed regardless of final use or configuration:

1. Paths to ground should be made as short as possible.
2. The ground pad of the SKY65174-21 has special electrical and thermal grounding requirements. This pad is the main thermal conduit for heat dissipation. Since the circuit board acts as the heat sink, it must shunt as much heat as possible from the device. Therefore, design the connection to the ground pad to dissipate the maximum wattage produced by the circuit board.  
  
Multiple vias to the grounding layer are required. For more details, refer to the Skyworks Application Note, *PCB Design Guidelines for High Power Dissipation Packages*, document number 201211.
3. Bypass capacitors should be used on the DC supply line (VCC). Refer to the schematic drawings in Figures 13 and 14 for further details.
4. The RF lines should be well separated from each other with solid ground in between traces to maximize input-to-output isolation.

*NOTE: A poor connection between the slug and ground increases junction temperature (T<sub>J</sub>), which reduces the lifetime of the device.*

## Application Circuit Notes

**Center Ground.** It is extremely important to sufficiently ground the bottom ground pad of the device for both thermal and stability reasons. Multiple small vias are acceptable and work well under the device if solder migration is an issue.

**RF\_IN (pin 1).** The module includes an on board internal DC blocking capacitor for this pin signal ( $Z_0 = 50 \Omega$ ). All impedance matching is provided internal to the module.

**GND (pins 2, 4, 7, and 8).** Attach all ground pins to the RF ground plane with the largest diameter and lowest inductance via that the

layout allows. Multiple small vias are acceptable and work well under the device if solder migration is an issue.

**VCC (pin 3).** The supply voltage for all three stages is typically set to +5 V. Component C2 is a bypass capacitor, and C16 is a decoupling capacitor and energy storage component.

**VDET (pin 5).** The interstage detector output voltage signal is connected to component C9, which has a filtering function. This value can be adjusted or completely removed to speed up the detector response. Component R1 provides a load to the detector and acts as a biasing resistor.

**RF\_OUT (pin 6).** The module includes an on board internal DC blocking capacitor for this pin signal ( $Z_0 = 50 \Omega$ ). All impedance matching is provided internal to the module.

**VREF1 (pin 9) and VREF2 (pin 10).** Bias reference voltage for the PA. These signals can be operated from 2.75 V to 3.00 V (measured at the device pins). Additional filters may be implemented on VREF1 to enhance dynamic linearity performance. The filter is composed of a series 40  $\Omega$  resistor in parallel with a series 90  $\Omega$  resistor and 0.1  $\mu$ F capacitor. VREF1 and VREF2 may be used as PA enable pins and can be pulled down to 0 V to disable the PA.

## Package Dimensions

The PCB layout footprint for the SKY65174-21 is provided in Figure 16. Figure 17 shows the package dimensions for the 10-pin MCM, and Figure 18 provides the tape and reel dimensions.

## Package and Handling Information

Since the device package is sensitive to moisture absorption, it is baked and vacuum packed before shipping. Instructions on the shipping container label regarding exposure to moisture after the container seal is broken must be followed. Otherwise, problems related to moisture absorption may occur when the part is subjected to high temperature during solder assembly.

The SKY65174-21 is rated to Moisture Sensitivity Level 3 (MSL3) at 260 °C. It can be used for lead or lead-free soldering. For additional information, refer to the Skyworks Application Note, *PCB Design and SMT Assembly/Rework Guidelines for MCM-L Packages*, document number 101752.

Care must be taken when attaching this product, whether it is done manually or in a production solder reflow environment. Production quantities of this product are shipped in a standard tape and reel format.

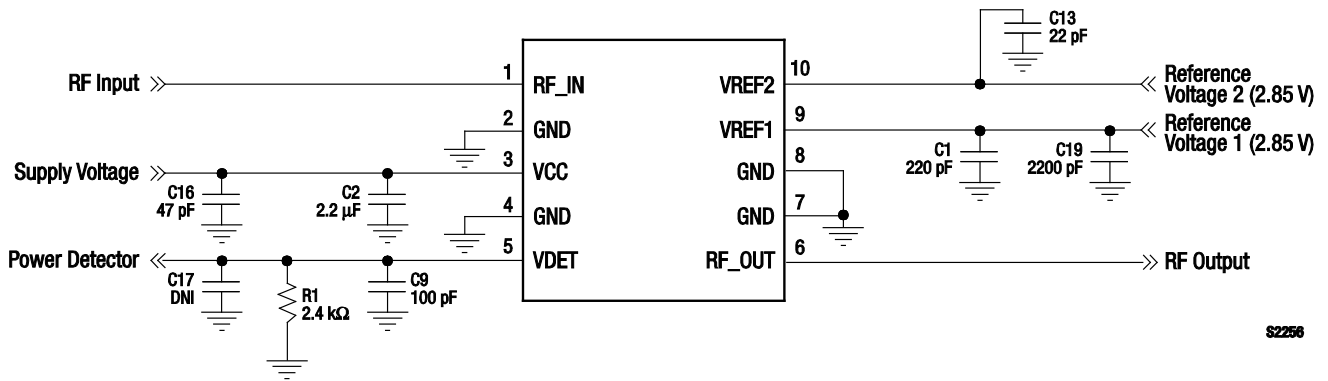

S2256

Figure 13. SKY65174-21 Application Schematic for Both 3.3 V and 5 V Operation

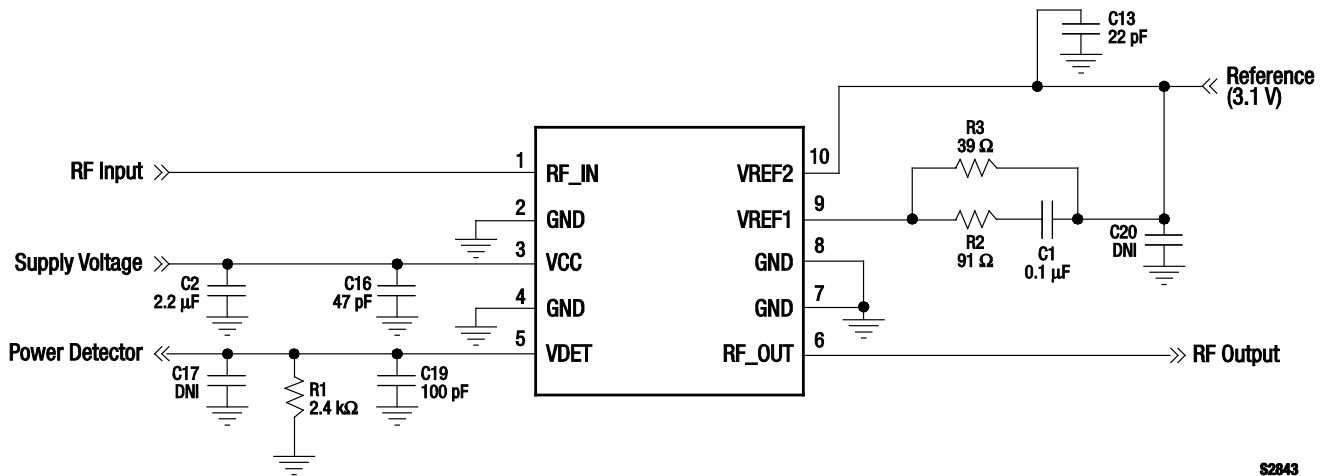

S2843

Figure 14. SKY65174-21 Application Schematic for Applications That Do Not Implement Amplitude Tracking



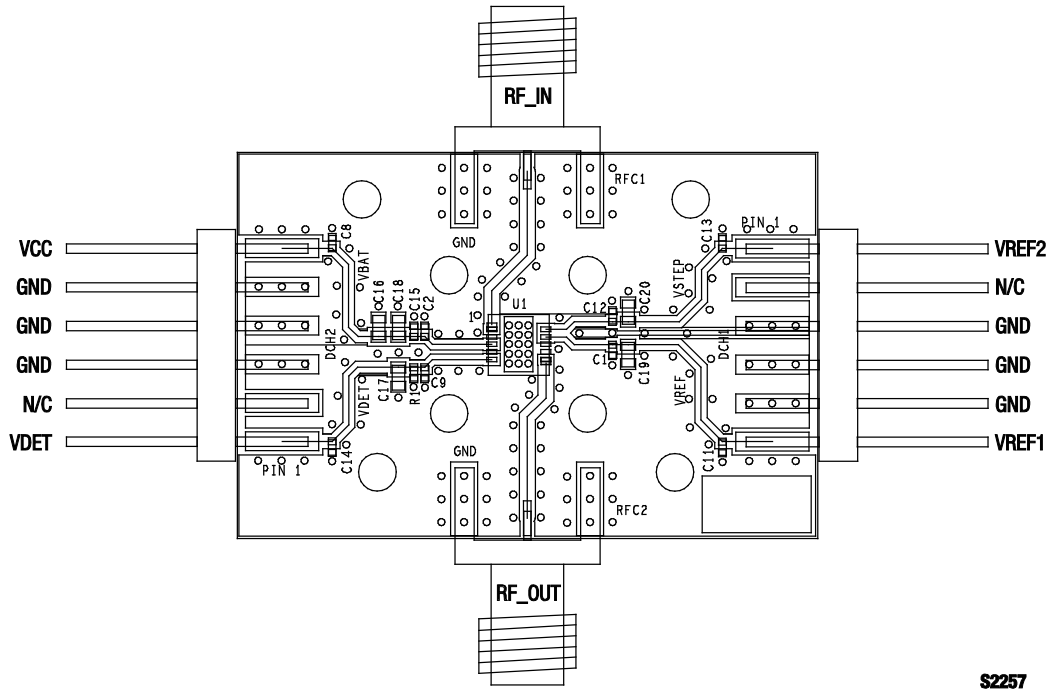
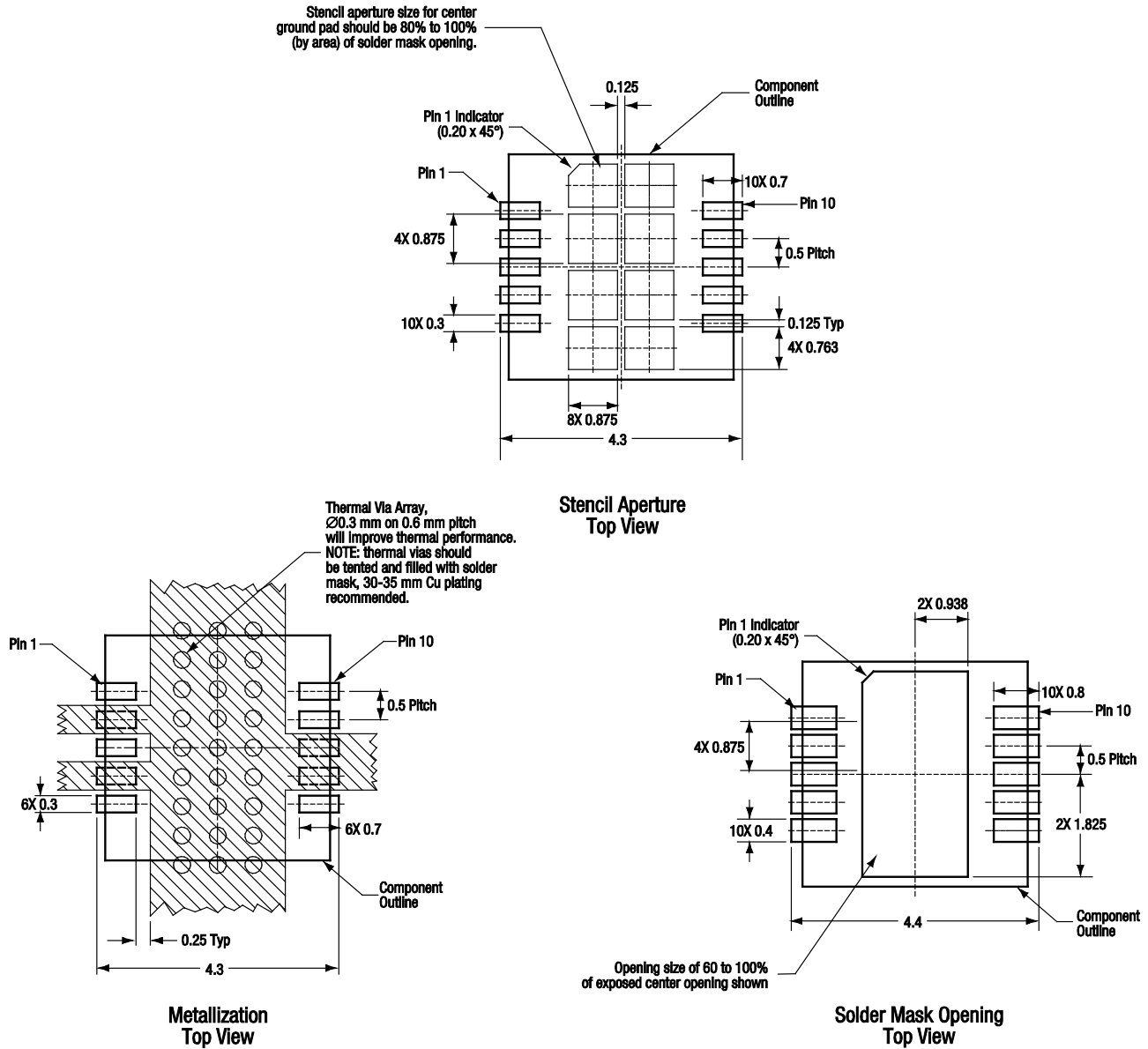

Figure 15. SKY65174-21 Evaluation Board Assembly Drawing

S2257



All dimensions are in millimeters

S2036

Figure 16. PCB Layout Footprint for the SKY65174-21 4 x 4 mm MCM

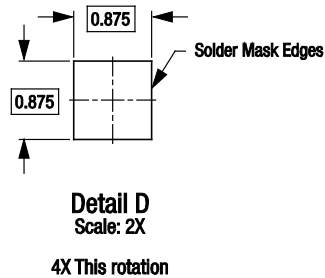
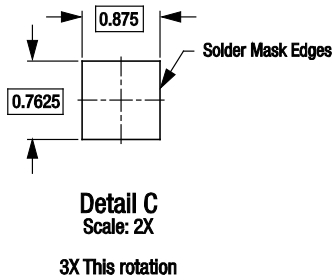
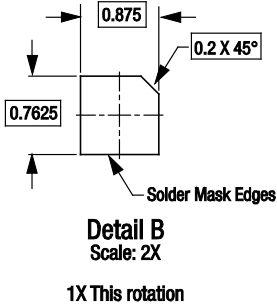
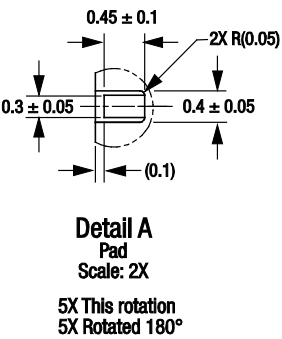
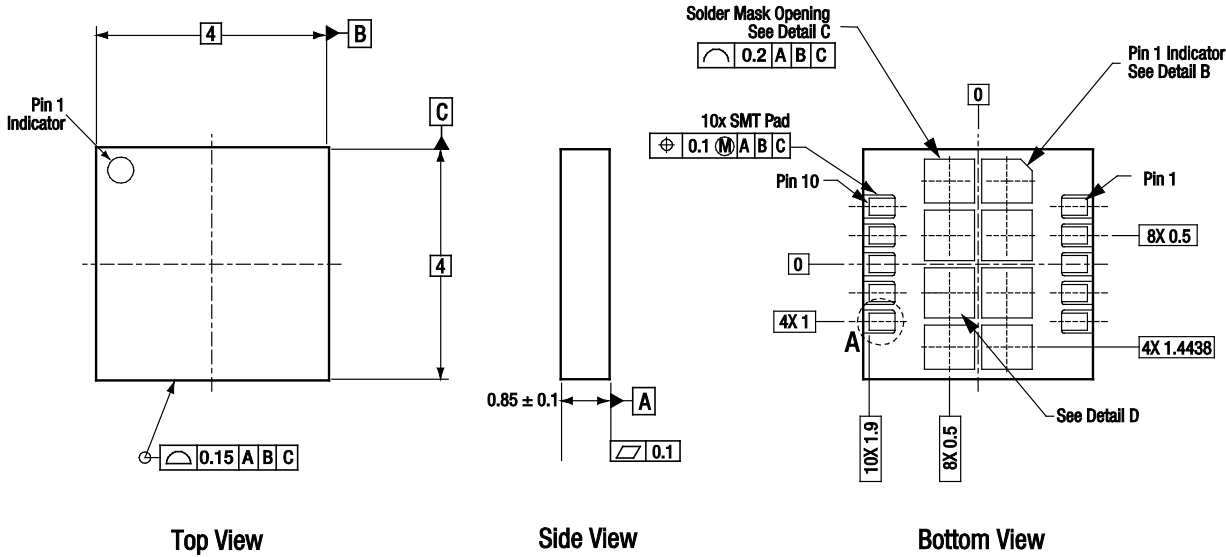

All measurements are in millimeters  
Dimensioning and tolerancing according to ASME Y14.5M-1994

S2039

Figure 17. SKY65174-21 10-Pin MCM Package Dimensions

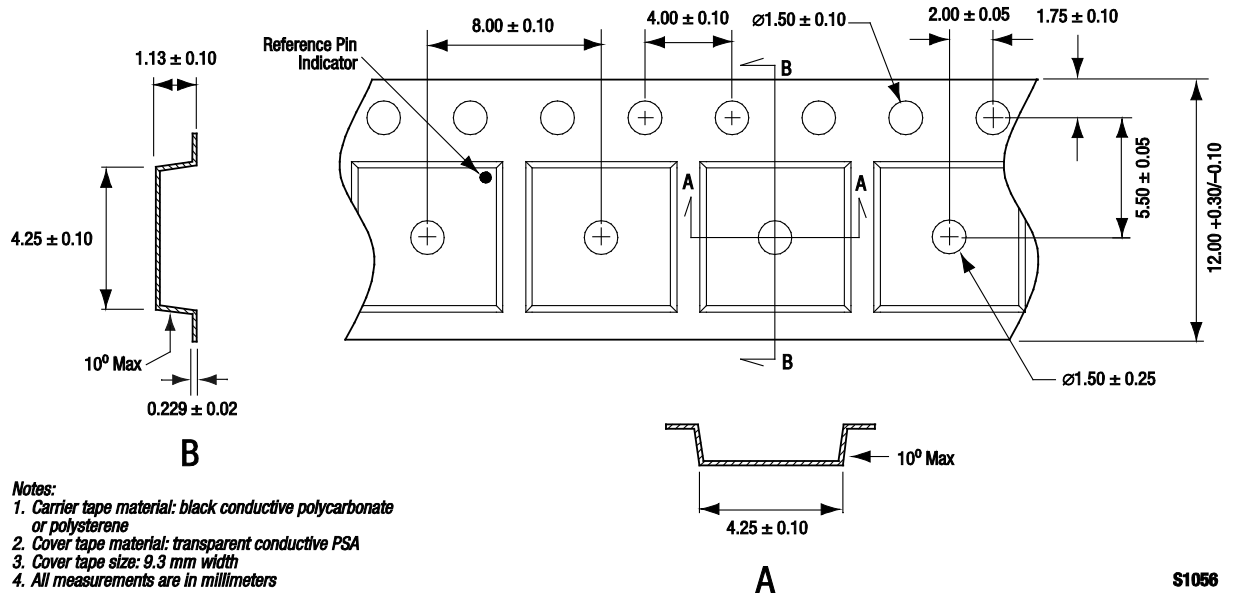

Figure 18. SKY65174-21 Tape and Reel Dimensions

**Ordering Information**

Model Name	Manufacturing Part Number	Evaluation Board Part Number
SKY65174-21 WLAN PAM	SKY65174-21	EN31-D662

Copyright © 2010, 2011, 2012 Skyworks Solutions, Inc. All Rights Reserved.

Information in this document is provided in connection with Skyworks Solutions, Inc. (“Skyworks”) products or services. These materials, including the information contained herein, are provided by Skyworks as a service to its customers and may be used for informational purposes only by the customer. Skyworks assumes no responsibility for errors or omissions in these materials or the information contained herein. Skyworks may change its documentation, products, services, specifications or product descriptions at any time, without notice. Skyworks makes no commitment to update the materials or information and shall have no responsibility whatsoever for conflicts, incompatibilities, or other difficulties arising from any future changes.

No license, whether express, implied, by estoppel or otherwise, is granted to any intellectual property rights by this document. Skyworks assumes no liability for any materials, products or information provided hereunder, including the sale, distribution, reproduction or use of Skyworks products, information or materials, except as may be provided in Skyworks Terms and Conditions of Sale.

THE MATERIALS, PRODUCTS AND INFORMATION ARE PROVIDED “AS IS” WITHOUT WARRANTY OF ANY KIND, WHETHER EXPRESS, IMPLIED, STATUTORY, OR OTHERWISE, INCLUDING FITNESS FOR A PARTICULAR PURPOSE OR USE, MERCHANTABILITY, PERFORMANCE, QUALITY OR NON-INFRINGEMENT OF ANY INTELLECTUAL PROPERTY RIGHT; ALL SUCH WARRANTIES ARE HEREBY EXPRESSLY DISCLAIMED. SKYWORKS DOES NOT WARRANT THE ACCURACY OR COMPLETENESS OF THE INFORMATION, TEXT, GRAPHICS OR OTHER ITEMS CONTAINED WITHIN THESE MATERIALS. SKYWORKS SHALL NOT BE LIABLE FOR ANY DAMAGES, INCLUDING BUT NOT LIMITED TO ANY SPECIAL, INDIRECT, INCIDENTAL, STATUTORY, OR CONSEQUENTIAL DAMAGES, INCLUDING WITHOUT LIMITATION, LOST REVENUES OR LOST PROFITS THAT MAY RESULT FROM THE USE OF THE MATERIALS OR INFORMATION, WHETHER OR NOT THE RECIPIENT OF MATERIALS HAS BEEN ADVISED OF THE POSSIBILITY OF SUCH DAMAGE.

Skyworks products are not intended for use in medical, lifesaving or life-sustaining applications, or other equipment in which the failure of the Skyworks products could lead to personal injury, death, physical or environmental damage. Skyworks customers using or selling Skyworks products for use in such applications do so at their own risk and agree to fully indemnify Skyworks for any damages resulting from such improper use or sale.

Customers are responsible for their products and applications using Skyworks products, which may deviate from published specifications as a result of design defects, errors, or operation of products outside of published parameters or design specifications. Customers should include design and operating safeguards to minimize these and other risks. Skyworks assumes no liability for applications assistance, customer product design, or damage to any equipment resulting from the use of Skyworks products outside of stated published specifications or parameters.

Skyworks, the Skyworks symbol, Helios, and “Breakthrough Simplicity” are trademarks or registered trademarks of Skyworks Solutions, Inc., in the United States and other countries. Third-party brands and names are for identification purposes only, and are the property of their respective owners. Additional information, including relevant terms and conditions, posted at [www.skyworksinc.com](http://www.skyworksinc.com), are incorporated by reference.