

PRELIMINARY DATA SHEET

SKY65127: 700–800 MHz High Linearity 2 W Power Amplifier

Applications

- WCDMA/CDMA/TDMA/GSM/LTE
- Repeaters
- WLL and ISM band transmitter
- Mobile radios
- Femto cell base stations

Features

- High linearity: OIP3 > 44 dBm
- $P_{1\text{ dB}} > 32.5\text{ dBm}$
- ACLR = -46 dBc for $P_{\text{OUT}} > 25\text{ dBm}$
- EVM < 3% for $P_{\text{OUT}} > 25\text{ dBm}$ (OFDM, 64-QAM)
- High efficiency: PAE 38%
- High gain: 36.5 dB
- Internal RF match and bias circuits
- Single DC supply: 5 V
- MCM (20-pin, 6 x 6 mm) lead (Pb)-free package (MSL-3 @ 260 °C per JEDEC J-STD-020)

Description

The SKY65127 is a fully matched 20-pin, lead-free, surface mount, Multichip Module (MCM) Power Amplifier (PA) designed for WCDMA/CDMA/TDMA/GSM/LTE radio, repeaters, transmitters, mobile radios and Femto cell base station applications operating in the 700–800 MHz bandwidth.

All active circuitry in the module is contained in a single Gallium Arsenide (GaAs) Microwave Monolithic Integrated Circuit (MMIC).

The device is manufactured with Skyworks Aluminum (Al) GaAs Heterojunction Bipolar Transistor (HBT) process, which allows for single supply operation while maintaining high efficiency and good linearity.

The module can operate over the temperature range of -40 °C to +85 °C. A populated evaluation board is available upon request.

NEW

Skyworks offers lead (Pb)-free, RoHS (Restriction of Hazardous Substances)-compliant packaging.



Preliminary Data Sheet: Based on engineering results. Sampling quantities available. Pin out and package have been determined.

Block Diagram

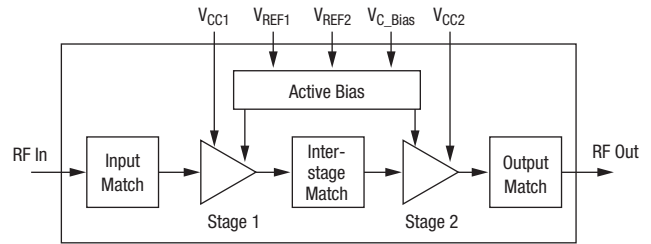

Package Diagram

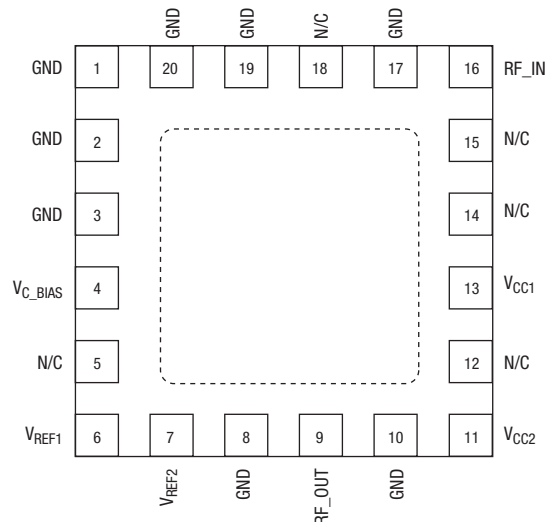

Electrical Specifications

V_{CC1} , V_{CC2} , V_{REF1} , V_{REF2} , V_{C_BIAS} = 5 V, Frequency = 750 MHz, T_C = 25 °C, unless otherwise specified

Parameter	Symbol	Condition	Min.	Typ.	Max.	Unit
Frequency	F		700		800	MHz
Gain	$ S_{21} $	Small signal	30	36.5		dB
Input return loss	$ S_{11} $	Small signal		9.6		dB
Output return loss	$ S_{22} $	Small signal		12		dB
Output power @ $P_{1\text{ dB}}$	$P_{1\text{ dB}}$	CW		32.5		dBm
Output 3rd order intercept	OIP3	$P_{\text{OUT}}/\text{tone} = 25\text{ dBm}$, tone spacing= 1 MHz	42	44		dBm
Noise figure	NF	CW		4.4	7	dB
ACLR1 @ $P_{\text{OUT}} = 25\text{ dBm}$	ACLR1	WCDMA test tone #1: 64 DPCH, $\Delta F = 5\text{ MHz}$		-46	-45	dBc
ACLR2 @ $P_{\text{OUT}} = 21\text{ dBm}$	ACLR2	WCDMA test tone #1: 64 DPCH, $\Delta F = 10\text{ MHz}$		-63.5	-55	dBc
Error vector magnitude	EVM	OFDM, 64-QAM, 54 Mbps, $P_{\text{OUT}} = 25\text{ dBm}$		2.1	3	%
Power-added efficiency	PAE	CW, $P_{\text{OUT}} @ P_{1\text{ dB}}$	35	38		%
Quiescent current	I_{CCQ}	No RF signal		264		mA

Absolute Maximum Ratings

Characteristic	Value
RF input power	0 dBm
Supply voltage (V_{CC} , V_{C_BIAS} , V_{REF})	6 V
Operating case temperature (T_C)	-40 °C to +85 °C
Storage temperature (T_{ST})	-55 °C to +125 °C
Junction temperature (T_J)	150 °C

Performance is guaranteed only under the conditions listed in the specifications table and is not guaranteed under the full range(s) described by the Absolute Maximum specifications. Exceeding any of the absolute maximum/minimum specifications may result in permanent damage to the device and will void the warranty. Each absolute maximum rating listed is an individual parameter. Biasing and driving the amplifier with more than one absolute maximum rating listed may result in permanent damage to the device. Exposure to maximum rating conditions for extended periods may reduce device reliability.

CAUTION: Although this device is designed to be as robust as possible, Electrostatic Discharge (ESD) can damage this device. This device must be protected at all times from ESD. Static charges may easily produce potentials of several kilovolts on the human body or equipment, which can discharge without detection. Industry-standard ESD precautions should be employed at all times.

Recommended Operating Conditions

Parameter	Symbol	Conditions	Min.	Typ.	Max.	Unit
Supply voltage	V_{CC} , V_{REF} , V_{C_BIAS}			5		V
Operating frequency	F_0		700		800	MHz
Operating case temperature	T_C		-40	+25	+85	°C

Typical Performance Data

V_{CC1} , V_{CC2} , V_{REF1} , V_{REF2} , V_{C_BIAS} = 5 V, Frequency = 750 MHz, T_C = 25 °C, unless otherwise specified.

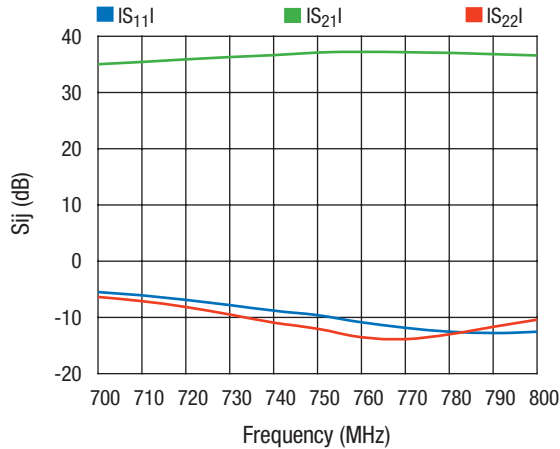

S-Parameters vs. Frequency

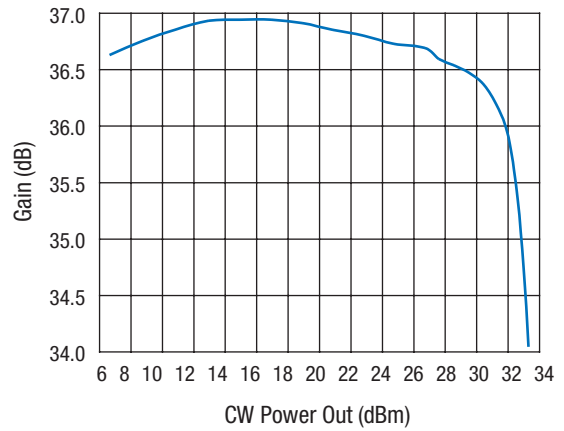

Gain vs. Power Out

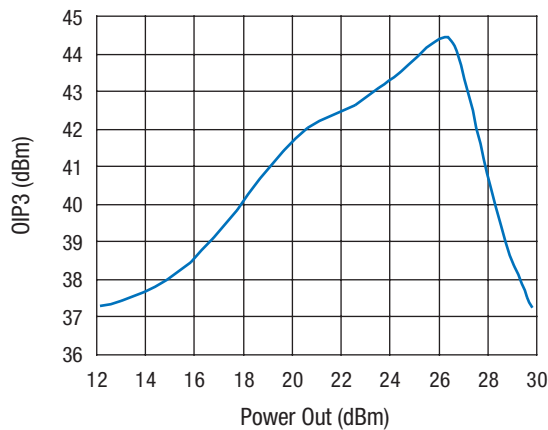

**OIP3 vs. Power Out
Tone Spacing = 1 MHz**

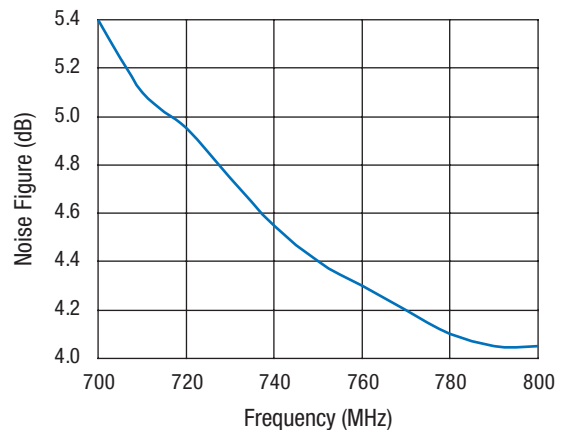

Noise Figure vs. Frequency

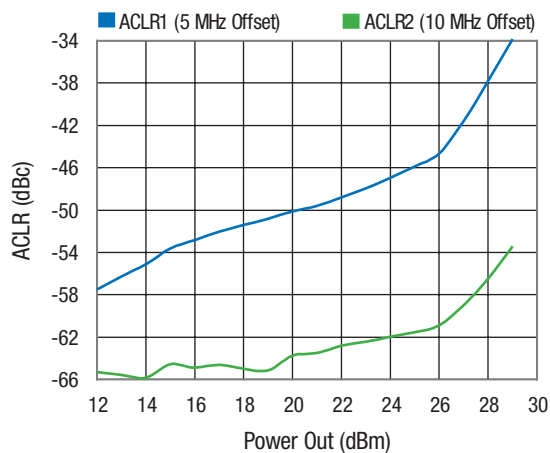

**ACLR vs. Power Out
WCDMA Test Tone #1; 64 DPCH ΔF = 5 and 10 MHz**

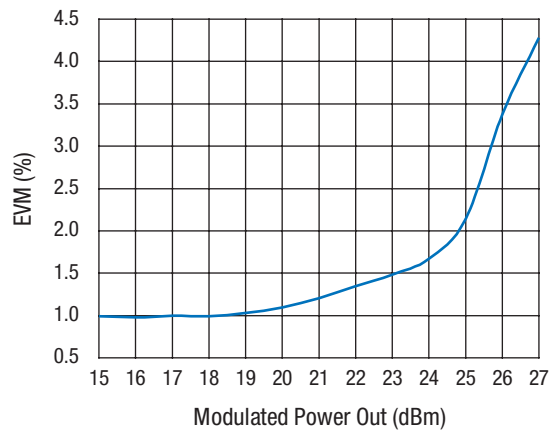

**EVM vs. Modulated Power Out
OFDM, 64-QAM, 54 Mbps**

Theory of Operation

The SKY65127 is comprised of two amplifier stages. The matching circuits for the input stage, inter-stage, and output stage are contained within the device. An on-chip active bias circuit is included within the device for both input and output stages providing for excellent gain tracking over temperature and voltage variations.

The SKY65127 is internally matched for optimum linearity and efficiency. The input and output stages are independently supplied using the V_{CC1} and V_{CC2} supply lines, pins 13 and 11, respectively. The bias reference voltages for stages 1 and 2 are supplied using common lines V_{REF1} and V_{REF2} (pins 6 and 7) line. The DC control voltage that sets the bias to stages 1 and 2 is supplied via V_{C_BIAS} , pin 4.

Application Circuit Notes

Center Ground. It is extremely important that the device paddle be sufficiently grounded for both thermal and stability reasons. Multiple small vias are acceptable and will work well under the device if solder migration is an issue.

Ground (Pins 1, 2, 3, 8, 10, 17, 19, 20). Attach all ground pins to the RF ground plane with the largest diameter and lowest inductance via that the layout will allow. Multiple small vias are also acceptable and will work well under the device if solder migration is an issue.

No Connect (Pins 5, 12, 14, 15, 18). The pins are open and may or may not be connected to ground.

V_{C_BIAS} (Pin 4). V_{C_BIAS} is the bias supply voltage for stages 1 and 2. Typically set to 5 V.

V_{REF1} (Pin 6). Bias reference voltage for amplifier stage 1. V_{REF1} should be operated over the same voltage range as V_{CC} , with a nominal voltage of 5 V.

V_{REF2} (Pin 7). Bias reference voltage for amplifier stage 2. V_{REF2} should be operated over the same voltage range as V_{CC} , with a nominal voltage of 5 V.

RF_OUT (Pin 9). Amplifier RF Output Pin. $Z_0 = 50 \Omega$. The module includes an onboard internal DC blocking capacitor. All impedance matching is provided internal to the module.

V_{CC2} (Pin 11). Supply voltage for the output (final) stage collector bias (typically 5 V). Bypassing of V_{CC2} is accomplished with C10, C11 and C12 and should be placed in the approximate location shown on the evaluation board, but placement is not critical.

V_{CC1} (Pin 13). Supply voltage for the first stage collector bias (typically 5 V). Bypassing of V_{CC1} is accomplished with C6, C7 and C8 and should be placed in the approximate location shown on the evaluation board, but placement is not critical.

RF_IN (Pin 16). Amplifier RF Input Pin. $Z_0 = 50 \Omega$. The module includes an onboard internal DC blocking capacitor. All impedance matching is provided internal to the module.

Package and Handling Information

Since the device package is sensitive to moisture absorption, it is baked and vacuum packed before shipping. Instructions on the shipping container label regarding exposure to moisture after the container seal is broken must be followed. Otherwise, problems related to moisture absorption may occur when the part is subjected to high temperature during solder assembly.

Please refer to Skyworks' *Solder Reflow* application note, available at www.skyworksinc.com, for instructions on mounting the SKY65127 to a printed circuit board.

Production quantities of this product are shipped in a standard tape and reel format. For packaging details, refer to the Skyworks *Tape and Reel* application note, document number 101568.

Electrostatic Discharge (ESD) Sensitivity

The SKY65127 is a static-sensitive electronic device. Do not operate or store near strong electrostatic fields. Take proper ESD precautions.

Application Circuit

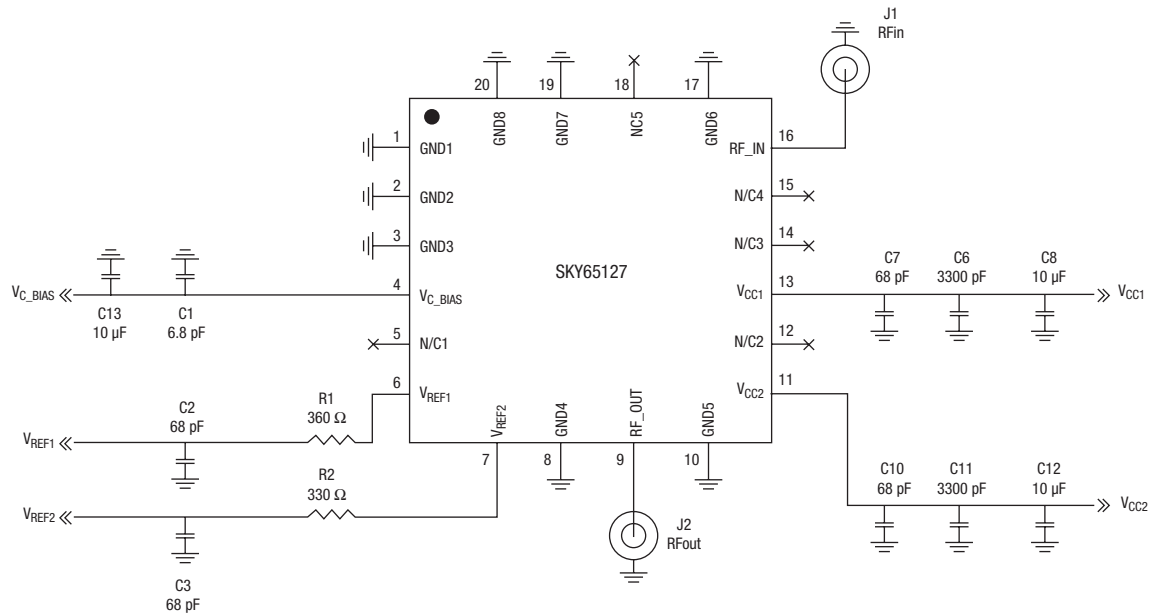

Pin Assignments

Pin	Pin Name	Description
1	GND	Low inductance ground connection
2	GND	Low inductance ground connection
3	GND	Low inductance ground connection
4	V _{C_BIAS}	Bias voltage
5	N/C	No connect
6	V _{REF1}	Bias reference voltage 1
7	V _{REF2}	Bias reference voltage 2
8	GND	Low inductance ground connection
9	RF_OUT	RF output
10	GND	Low inductance ground connection
11	V _{CC2}	Stage 2 collector voltage
12	N/C	No connect
13	V _{CC1}	Stage 1 collector voltage
14	N/C	No connect
15	N/C	No connect
16	RF_IN	RF input
17	GND	Low inductance ground connection
18	N/C	No connect
19	GND	Low inductance ground connection
20	GND	Low inductance ground connection

Center attachment pad must have a low inductance and low thermal resistance connection to the customer's printed circuit board ground plane.

Evaluation Board Description

The Skyworks SKY65127 Evaluation Board is used to test the performance of the SKY65127 power amplifier module. The following design considerations are general in nature and must be followed regardless of final use or configuration.

1. Paths to ground should be made as short as possible.
2. The ground pad of the SKY65127 power amplifier module has special electrical and thermal grounding requirements. This pad is the main thermal conduit for heat dissipation. Since the circuit board acts as the heat sink, it must shunt as much heat as possible from the amplifiers. As such, design the connection to the ground pad to dissipate the maximum wattage produced to the circuit. Multiple vias to the grounding layer are required.

NOTE: Junction temperature (T_j) of the device increases with a poor connection to the slug and ground. This reduces the lifetime of the device.

Evaluation Board

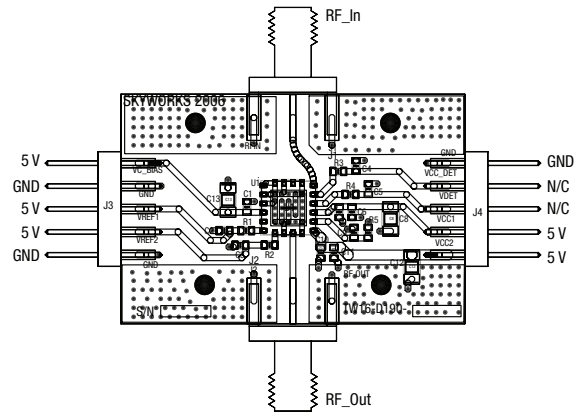

Evaluation Board Test Procedure

- Step 1. Connect RF test equipment to amplifier input/output SMA connectors.
- Step 2. Connect DC ground.
- Step 3. Connect all V_{CC}, V_{REG} and V_{C_BIAS} lines to 5 V supply. Verify the I_{CCQ} current is approximately 264 mA.
- Step 4. Apply RF signal data -20 dBm level and observe that the output level is approximately 16.5 dBm or the gain of the device is approximately 36.5 dB.

NOTE: It is important that the V_{CC1} and V_{CC2} voltage source be adjusted such that 5 V is measured at the board. The high collector currents will drop the collector voltage significantly if long leads are used. Adjust the bias voltage to compensate.

Recommended Solder Reflow Profiles

Refer to the [“Recommended Solder Reflow Profile”](#) Application Note.

Tape and Reel Information

Refer to the [“Discrete Devices and IC Switch/Attenuators Tape and Reel Package Orientation”](#) Application Note.

Evaluation Board Layer Detail

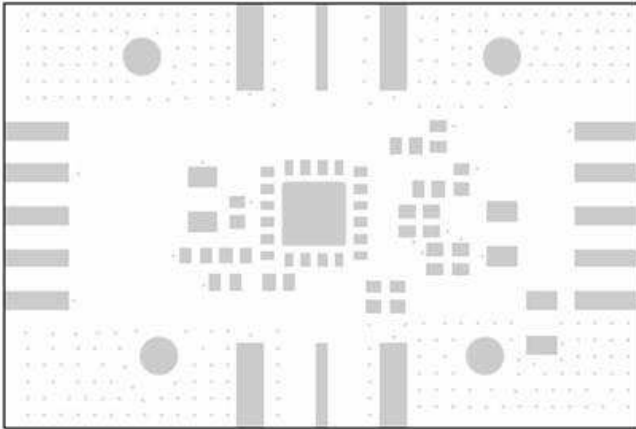

Layer 1: Solder Mask

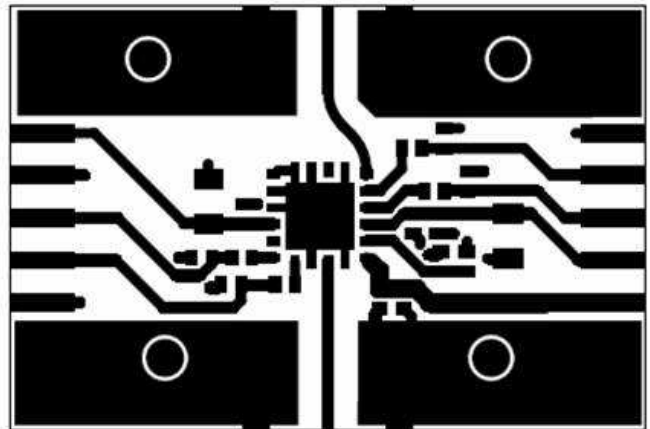

Layer 1: Top Metal

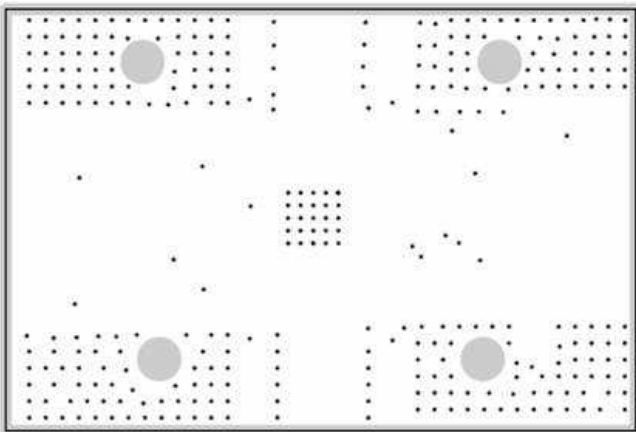

Layer 2 and 3: Ground

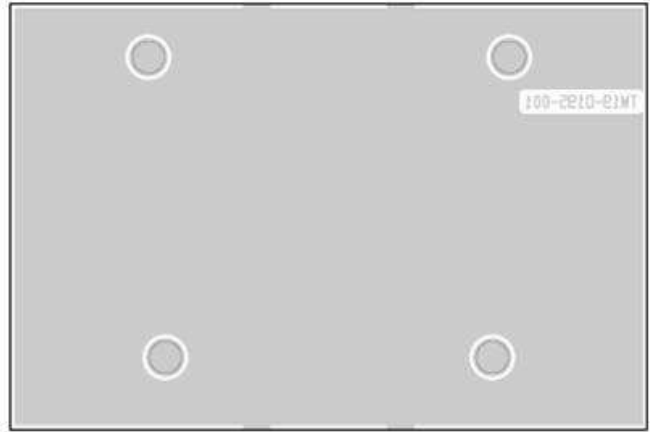

Layer 4: Solid Ground Plane

Bill of Material for Evaluation Board

Part	ID	QTY	Size	Value	Units	Product Number	Manufacturer	Manufacturer's Part Number	Characteristics
1	C1	1	0603	3300	pF	SK204-000-007	Murata	GRM188R71H332KA01D	X7R, 50 V, ± 10%
2	C2	1	0603	68	pF	5404R23-023	Murata	GRM1885C1H680JA01D	COG, 50 V, ± 5%
3	C3	1	0603	68	pF	5404R23-023	Murata	GRM1885C1H680JA01D	COG, 50 V, ± 5%
4	C6	1	0603	3300	pF	SK204-000-007	Murata	GRM188R71H332KA01D	X7R, 50 V, ± 10%
5	C7	1	0603	68	pF	5404R23-023	Murata	GRM1885C1H680JA01D	COG, 50 V, ± 5%
6	C8	1	1206	10	µF	5404R91-005	TDK	C3216X5R0J106KT	X5R, 6 V, ± 10%
7	C10	1	0603	68	pF	5404R23-023	Murata	GRM1885C1H680JA01D	COG, 50 V, ± 5%
8	C11	1	0603	3300	pF	SK204-000-007	Murata	GRM188R71H332KA01D	X7R, 50 V, ± 10%
9	C12	1	1206	10	µF	5404R91-005	TDK	C3216X5R0J106KT	X5R, 6 V, ± 10%
10	C13	1	1206	10	µF	5404R91-005	TDK	C3216X5R0J106KT	X5R, 6 V, ± 10%
11	R1	1	0603	360	Ω	5424R20-038	Rohm	MCR03EZHUJ360	50 V, 0.063 W, ± 5%
12	R2	1	0603	330	Ω	5424R20-037	Rohm	MCR03EZHUJ330	50 V, 0.063 W, ± 5%

Evaluation Board Stack-Up

Cross Section	Name	Thickness (mils)	Material	ε _r
	L1	1.4	Cu	-
	Lam1	12	Rogers 4003-12	3.38
	L2_GND	1.4	Cu, 1 oz.	-
	Lam2	4	FR4-4	4.35
	L3_GND	1.4	Cu, 1 oz.	-
	Lam3	12	FR4-12	4.35
	L4	1.4	Cu, 1 oz.	-

Branding Specifications

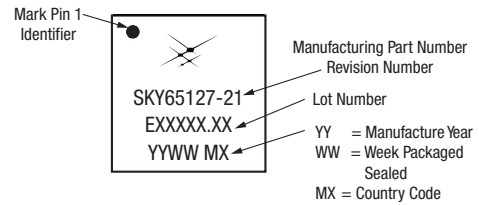

Package Dimensions

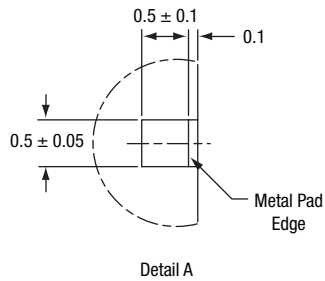
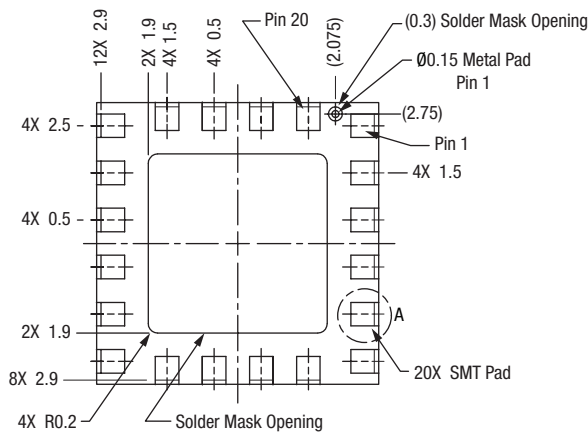
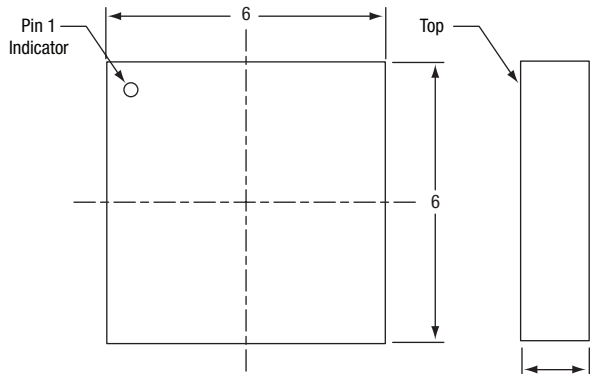

All dimensions are in millimeters
Dimensioning and tolerancing according
to ASME Y14.5M-1994

Recommended Footprint

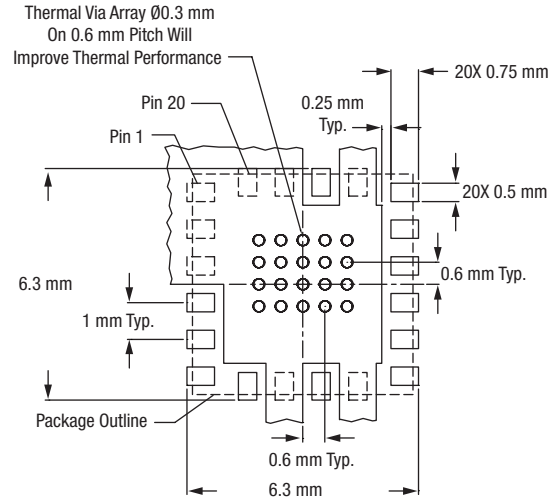

Solder Mask

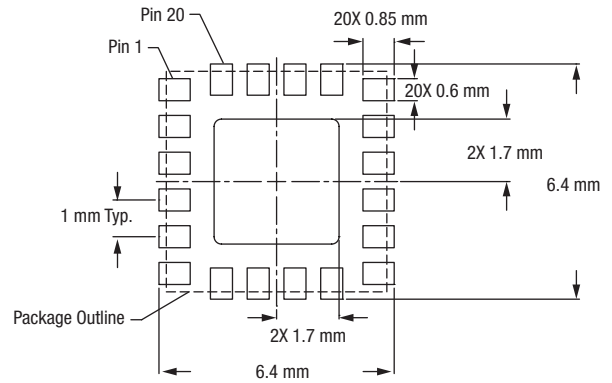

Stencil Pattern

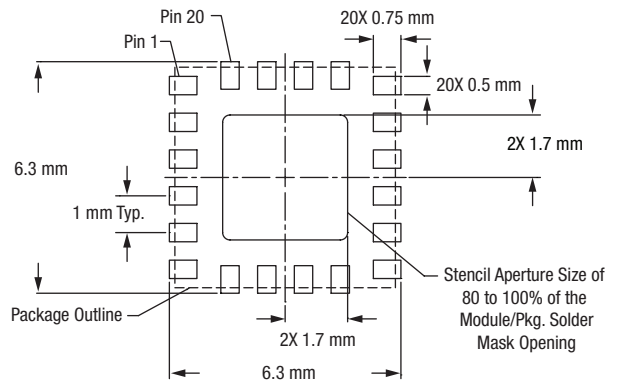

Tape and Reel Dimensions

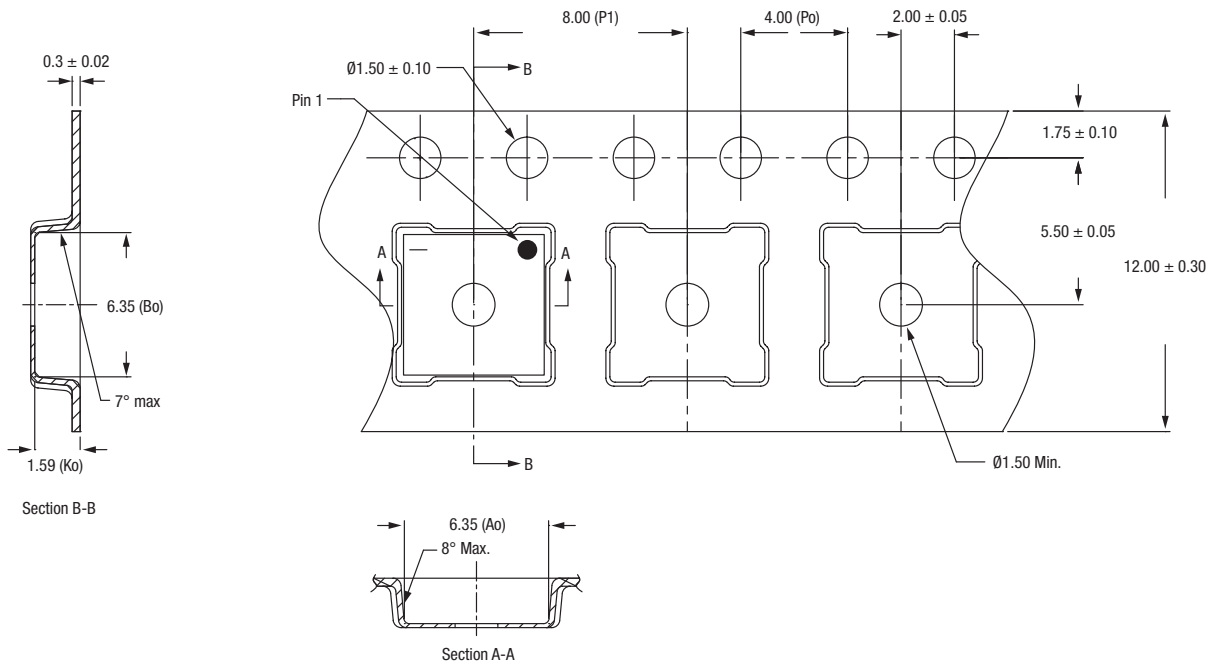

1. Carrier tape: black conductive polystyrene
2. Cover tape material: transparent conductive PSA
3. Cover tape size: 9.3 mm width
4. All dimensions are in millimeters

Ordering Information

Model Name	Manufacturing Part Number	Evaluation Kit Part Number
SKY65127: 700–800 MHz High Linearity 2 W Power Amplifier	SKY65127-21 (Pb-free package)	TW17-D510-001

Copyright © 2008, 2009, Skyworks Solutions, Inc. All Rights Reserved.

Information in this document is provided in connection with Skyworks Solutions, Inc. (“Skyworks”) products or services. These materials, including the information contained herein, are provided by Skyworks as a service to its customers and may be used for informational purposes only by the customer. Skyworks assumes no responsibility for errors or omissions in these materials or the information contained herein. Skyworks may change its documentation, products, services, specifications or product descriptions at any time, without notice. Skyworks makes no commitment to update the materials or information and shall have no responsibility whatsoever for conflicts, incompatibilities, or other difficulties arising from any future changes.

No license, whether express, implied, by estoppel or otherwise, is granted to any intellectual property rights by this document. Skyworks assumes no liability for any materials, products or information provided hereunder, including the sale, distribution, reproduction or use of Skyworks products, information or materials, except as may be provided in Skyworks Terms and Conditions of Sale.

THE MATERIALS, PRODUCTS AND INFORMATION ARE PROVIDED “AS IS” WITHOUT WARRANTY OF ANY KIND, WHETHER EXPRESS, IMPLIED, STATUTORY, OR OTHERWISE, INCLUDING FITNESS FOR A PARTICULAR PURPOSE OR USE, MERCHANTABILITY, PERFORMANCE, QUALITY OR NON-INFRINGEMENT OF ANY INTELLECTUAL PROPERTY RIGHT; ALL SUCH WARRANTIES ARE HEREBY EXPRESSLY DISCLAIMED. SKYWORKS DOES NOT WARRANT THE ACCURACY OR COMPLETENESS OF THE INFORMATION, TEXT, GRAPHICS OR OTHER ITEMS CONTAINED WITHIN THESE MATERIALS. SKYWORKS SHALL NOT BE LIABLE FOR ANY DAMAGES, INCLUDING BUT NOT LIMITED TO ANY SPECIAL, INDIRECT, INCIDENTAL, STATUTORY, OR CONSEQUENTIAL DAMAGES, INCLUDING WITHOUT LIMITATION, LOST REVENUES OR LOST PROFITS THAT MAY RESULT FROM THE USE OF THE MATERIALS OR INFORMATION, WHETHER OR NOT THE RECIPIENT OF MATERIALS HAS BEEN ADVISED OF THE POSSIBILITY OF SUCH DAMAGE.

Skyworks products are not intended for use in medical, lifesaving or life-sustaining applications, or other equipment in which the failure of the Skyworks products could lead to personal injury, death, physical or environmental damage. Skyworks customers using or selling Skyworks products for use in such applications do so at their own risk and agree to fully indemnify Skyworks for any damages resulting from such improper use or sale.

Customers are responsible for their products and applications using Skyworks products, which may deviate from published specifications as a result of design defects, errors, or operation of products outside of published parameters or design specifications. Customers should include design and operating safeguards to minimize these and other risks. Skyworks assumes no liability for applications assistance, customer product design, or damage to any equipment resulting from the use of Skyworks products outside of stated published specifications or parameters.

Skyworks, the Skyworks symbol, and “Breakthrough Simplicity” are trademarks or registered trademarks of Skyworks Solutions, Inc., in the United States and other countries. Third-party brands and names are for identification purposes only, and are the property of their respective owners. Additional information, including relevant terms and conditions, posted at www.skyworksinc.com, are incorporated by reference.