

GLOBAL PERFORMANCE SWITCHERS

FEATURES:

- 115 Watts of continuous power with forced air
- Power factor corrected
- 74-81% efficiency
- Small package 3.3" x 5.25" x 1.5" inches
- Power fail warning, remote sense
- Optional cover with cooling fan
- Medical Approval to UL2601-1, CSA-C22.2 No. 601.1, EN60601-1
- RoHS Compliant Model Available (G suffix)

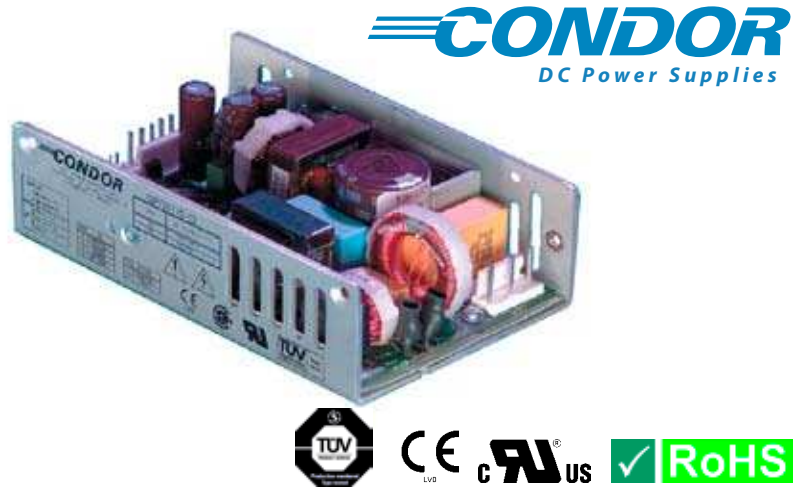

SPECIFICATIONS

| <p>Ac Input 85-264 Vac, 47-63 Hz single phase</p> | <p>Transient Response Main Output 500 μs typical response time for return to within 0.5% of final value for a 50% load step change, $\Delta i/\Delta t < 0.2$ A/μs. Maximum voltage deviation is 3.5%.</p> | | | | | | | | | | | | | | | | | | |
|--|---|--------------------|------------------|---------------------|------------------------------|------------------|-------------------------------------|-------------------------|------------------------|------------------------|--------------------------|----------------------|------------------------------------|--------------------------|---------------------|-----------------------------|------------------|--------------------------------|---|
| <p>Output Power Continuous rating is 80 W with unrestricted natural convection, or 115 W with forced convection. All models capable of 110% of rated power for 60 sec., 10% duty cycle maximum.</p> | <p>Minimum Load No minimum load required to maintain output specifications. An abrupt change in output current from > 90% to < 2% load may cause a false triggering of the power fail signal.</p> | | | | | | | | | | | | | | | | | | |
| <p>Input Current Maximum input current at 90 Vac, 60 Hz with full rated load is 1.7 A. Input current harmonic content meets the requirements of IEC1000-3-2 for all load conditions at 230 Vac input. Active input circuitry provides high power factor of .96 min, .99 typical.</p> | <p>Voltage Adjustment Main output $\pm 5\%$.</p> | | | | | | | | | | | | | | | | | | |
| <p>Inrush Current Inrush 240 Vac is less than 37 A, averaged over the first ac halfcycle under cold start conditions. Limiting provided by internal thermistors.</p> | <p>Temperature Coefficient 0.03%/$^{\circ}$C typical on all outputs.</p> | | | | | | | | | | | | | | | | | | |
| <p>Holdup Time 25 ms minimum from loss of ac input at full load.</p> | <p>Thermal Shutdown Provided as a standard feature. Designed to protect unit from prolonged over temperature.</p> | | | | | | | | | | | | | | | | | | |
| <p>Power Fail TTL / CMOS compatible output goes low (<0.5 V) 8 ms before output voltage drops more than 4% below nominal voltage upon loss of ac power. The signal is factory set to trip before there is insufficient power stored in the primary to sustain the output. Signal can sink 1.6 mA or source 400 μA at 2.7 V (Fan-out = 1).</p> | <p>Fan Output An additional 12 Vdc (nominal 10.5 V), 100 mA output suitable for powering a dc fan is included in all models. The fan output is referenced to +out. Due to high pk-pk noise and low regulation, it is not recommended that this output be used for any other purpose.</p> | | | | | | | | | | | | | | | | | | |
| <p>Efficiency 74 to 81% depending upon model</p> | <p>Input Protection Internal ac fuse provided on all models. Fuse does not blow on overload or short circuit -- fuse blows only if a catastrophic failure occurs in the unit.</p> | | | | | | | | | | | | | | | | | | |
| <p>DC Output Specification Total regulation is the maximum deviation from the nominal voltage for all steady state loading conditions. Peak ratings are for 60 s maximum duration, 10% duty cycle. Consult factory for application assistance.</p> | <p>EMI/EMC Compliance All models include built-in EMI filtering to meet the following emissions requirements:</p> <table border="1"> <thead> <tr> <th>EMI SPECIFICATIONS</th> <th>COMPLIANCE LEVEL</th> </tr> </thead> <tbody> <tr> <td>Conducted Emissions</td> <td>EN55011 Class B; FCC Class B</td> </tr> <tr> <td>Static Discharge</td> <td>EN61000-4-2, 6 kV contact, 8 kV air</td> </tr> <tr> <td>RF Field Susceptibility</td> <td>EN61000-4-3, 3 V/meter</td> </tr> <tr> <td>Fast Transients/Bursts</td> <td>EN61000-4-4, 2 kV, 5 kHz</td> </tr> <tr> <td>Surge Susceptibility</td> <td>EN61000-4-5, 1 kV diff., 2 kV com.</td> </tr> <tr> <td>Line Frequency Harmonics</td> <td>EN61000-3-2 Class A</td> </tr> <tr> <td>Conducted RF Susceptibility</td> <td>EN61000-4-6, 3 V</td> </tr> <tr> <td>Voltage Dips and Interruptions</td> <td>EN61000-4-11, Consult factory for more details.</td> </tr> </tbody> </table> | EMI SPECIFICATIONS | COMPLIANCE LEVEL | Conducted Emissions | EN55011 Class B; FCC Class B | Static Discharge | EN61000-4-2, 6 kV contact, 8 kV air | RF Field Susceptibility | EN61000-4-3, 3 V/meter | Fast Transients/Bursts | EN61000-4-4, 2 kV, 5 kHz | Surge Susceptibility | EN61000-4-5, 1 kV diff., 2 kV com. | Line Frequency Harmonics | EN61000-3-2 Class A | Conducted RF Susceptibility | EN61000-4-6, 3 V | Voltage Dips and Interruptions | EN61000-4-11, Consult factory for more details. |
| EMI SPECIFICATIONS | COMPLIANCE LEVEL | | | | | | | | | | | | | | | | | | |
| Conducted Emissions | EN55011 Class B; FCC Class B | | | | | | | | | | | | | | | | | | |
| Static Discharge | EN61000-4-2, 6 kV contact, 8 kV air | | | | | | | | | | | | | | | | | | |
| RF Field Susceptibility | EN61000-4-3, 3 V/meter | | | | | | | | | | | | | | | | | | |
| Fast Transients/Bursts | EN61000-4-4, 2 kV, 5 kHz | | | | | | | | | | | | | | | | | | |
| Surge Susceptibility | EN61000-4-5, 1 kV diff., 2 kV com. | | | | | | | | | | | | | | | | | | |
| Line Frequency Harmonics | EN61000-3-2 Class A | | | | | | | | | | | | | | | | | | |
| Conducted RF Susceptibility | EN61000-4-6, 3 V | | | | | | | | | | | | | | | | | | |
| Voltage Dips and Interruptions | EN61000-4-11, Consult factory for more details. | | | | | | | | | | | | | | | | | | |
| <p>Remote Sense Provided as a standard feature on all models. Capable of compensating for 0.25 V total of cabling losses.</p> | <p>Leakage Current 90 μA normal conditions (132 Vac @ 60 Hz input) or 250 μA (264 Vac) single fault.</p> | | | | | | | | | | | | | | | | | | |
| <p>Overload Protection Fully protected against short circuit and output overload. Short circuit protection is cycling type power limit. Recovery after fault is automatic. Consult factory for specific condition limits.</p> | <p>Medical Safety All models are Certified to be in compliance with the applicable requirements of UL 2601, CSA 22.2 No. 601.1-M90, IEC 601-1 (1988), EN 60601-1: 1990. (Consult factory for approval status)</p> | | | | | | | | | | | | | | | | | | |
| <p>Overvoltage Protection Built in on all models - See voltage and current chart for individual model output limits. When OVP fires, the output converter stops providing input power to output. Output voltage decay is dependent upon loading.</p> | | | | | | | | | | | | | | | | | | | |
| <p>Output Noise 0.5% rms, 1% pk-pk, 20 MHz Bandwidth, differential mode. Measured with noise probe directly across output terminals of the power supply.</p> | | | | | | | | | | | | | | | | | | | |

All specifications are typical at nominal input, full load at 25 $^{\circ}$ C unless otherwise stated

| Medical Model | RoHS Suffix* | Voltage Output | Output Adjustment | Output Maximum (A) | Maximum (B) | Output Peak | Total Regulation | OVP Setpoint | Ripple/Noise | Notes |
|---------------|--------------|----------------|-------------------|--------------------|-------------|-------------|------------------|--------------|--------------|-------|
| GPFM115-5 | G | 5.1 V | ±5% | 12 A | 20 A | 25 A | 2% | 6.2 ± 0.6 V | 1% | C |
| GPFM115-12 | G | 12 V | ±5% | 6.7 A | 9.6 A | 10.8 A | 2% | 14 ± 1.1 V | 1% | C |
| GPFM115-13 | G | 13 V | ±5% | 6.2 A | 8.8 A | 9.9 A | 2% | 15 ± 1.1 V | 1% | C |
| GPFM115-15 | G | 15 V | ±5% | 5.3 A | 7.7 A | 8.7 A | 2% | 18.5 ± 1.5 V | 1% | C |
| GPFM115-24 | G | 24 V | ±5% | 3.3 A | 4.8 A | 5.4 A | 2% | 28 ± 2.5 V | 1% | C |
| GPFM115-28 | G | 28 V | ±5% | 2.9 A | 4.1 A | 4.6 A | 2% | 34 ± 2.8 V | 1% | C |
| GPFM115-48 | G | 48 V | ±5% | 1.7 A | 2.4 A | 2.7 A | 2% | 55 ± 4.0 V | 1% | C |

Notes:

* Add "G" suffix to part number for RoHS compliant model.

A. Maximum continuous current rating for unrestricted convection cooling.

B. Maximum continuous current rating with 150 LFM air or cover option.

C. Add "-C" after voltage in model number for cover with fan option.

GPFM115 MECHANICAL SPECIFICATIONS

WEIGHT: 1.9 LBS [0.86 kg] MAX.

J1 INPUT: (AMP P.C.B. HEADER P/N 640445-5)

PIN 1) AC LINE
 PIN 2) = N/C
 PIN 3) = AC NEUTRAL
 PIN 4) = N/C
 PIN 5) = AC GROUND

SIGNALS: J2

AMP P.C.B. HEADER P/N 640456-4
 MATING CONNECTOR P/N 640621-4
 PIN 1) POWER FAIL
 PIN 2) -SENSE
 PIN 3) +SENSE
 PIN 4) COMMON

FAN: J4

AMP P.C.B. HEADER P/N 640456-2
 MATING CONNECTOR P/N 640621-2
 PIN 1) -
 PIN 2) +

OUTPUT

J3- 5A MAXIMUM CONTINUOUS CURRENT PER CONNECTOR PIN.
 AMP P.C.B. HEADER P/N 640445-8
 PIN 1-4) +Vout
 PINS 5-8) RETURN
 OUTPUT-MATING CONNECTOR AMP P/N HOUSING 640250-8
 CONTACT 770476-1
 INPUT MATING CONNECTOR AMP P/N HOUSING 640250-5
 CONTACT 770476-1
 MAX. SCREW PROTRUSION THROUGH CHASSIS = 0.08" [2 MM], CHASSIS THICKNESS = 0.080" [2 MM]

OPTIONAL COVER/FAN ASSEMBLY
 AVAILABLE P/N 09-115CF

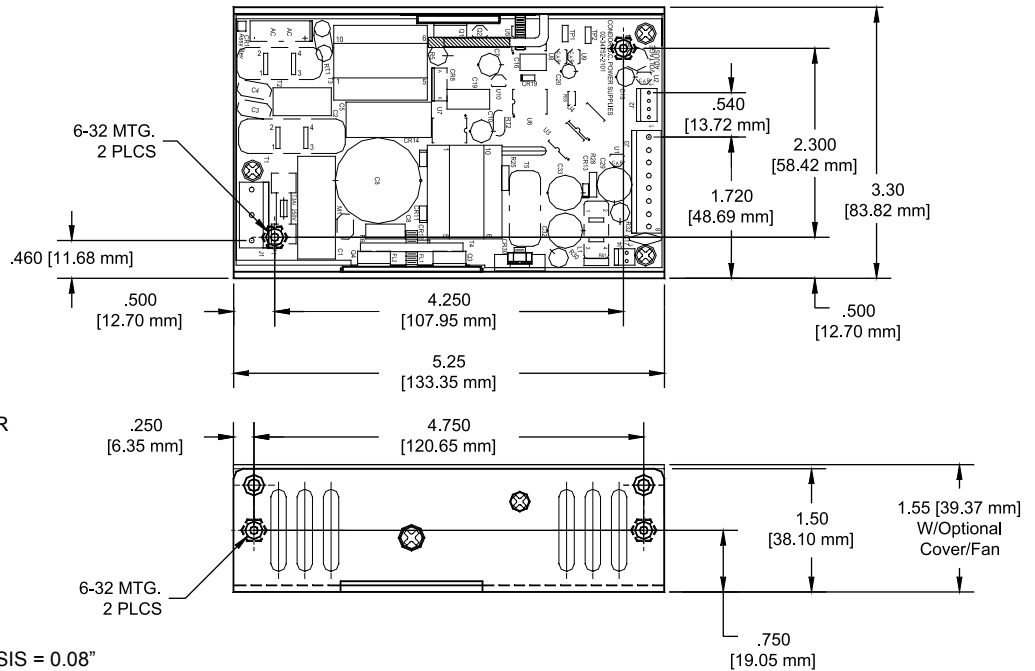

| ENVIRONMENTAL SPECIFICATIONS | OPERATING | NON-OPERATING |
|------------------------------|---|---|
| Temperature (A) | 0 to 50° | -40 to +85°C |
| Humidity (A) | 0 to 95% RH | 0 to 95% RH |
| Shock (B) | 20 g _{pk} | 40 g _{pk} |
| Altitude | -500 to 10,000 ft | -500 to 40,000 ft |
| Vibration (C) | 1.5 g _{rms} , 0.003 g ² /Hz | 5 g _{rms} , 0.026 g ² /Hz |

A. Units should be allowed to warm up/operate under non-condensing conditions before application of power. Derate output current and total output power by 2.5% per °C above 50°C. For operation in a confined space, moving air may be required. Under all conditions, the cooling vs. load profile should be such that chassis temperatures do not exceed 90°C for extended periods.

B. Shock testing—half-sinusoidal, 10 ± 3 ms duration, ± direction, 3 orthogonal axes, total 6 shocks.

C. Random vibration—10 to 2000Hz, 6dB/octave roll-off from 350 to 2000Hz, 3 orthogonal axes. Tested for 10 min./axis operating and 1 hr./axis non-operating.