

3.3 V 16 K / 32 K / 64 K × 16 / 18 Synchronous Dual-Port Static RAM

Features

- True dual-ported memory cells that allow simultaneous access of the same memory location
- Six flow through/pipelined devices:
 - 16 K × 16 / 18 organization (CY7C09269V/369V)
 - 32 K × 16 organization (CY7C09279V)
 - 64 K × 16 / 18 organization (CY7C09289V/389V)
- Three modes:
 - Flow through
 - Pipelined
 - Burst
- Pipelined output mode on both ports allows fast 100 MHz operation
- 0.35 micron CMOS for optimum speed and power
- High speed clock to data access: 7.5^[1], 9, 12 ns (max)
- 3.3 V low operating power:
 - Active = 115 mA (typical)
 - Standby = 10 μA (typical)
- Fully synchronous interface for easier operation
- Burst counters increment addresses internally:
 - Shorten cycle times
 - Minimize bus noise
 - Supported in flow through and pipelined modes
- Dual chip enables easy depth expansion
- Upper and lower byte controls for bus matching
- Automatic power down
- Commercial and industrial temperature ranges
- Pb-free 100-pin TQFP package available

Logic Block Diagram

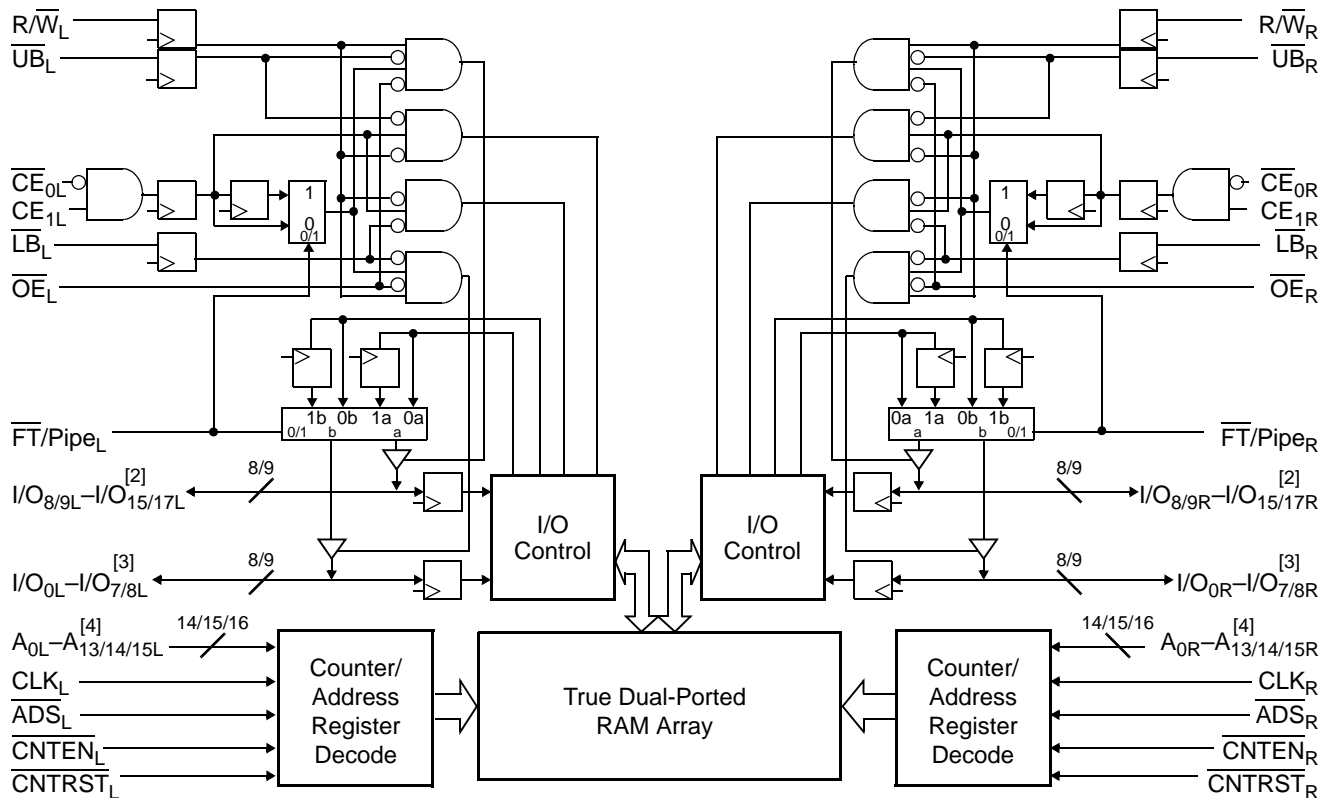

Notes

1. See Figure 4 on page 8 for Load Conditions.
2. I/O₈-I/O₁₅ for × 16 devices; I/O₉-I/O₁₇ for × 18 devices.
3. I/O₀-I/O₇ for × 16 devices. I/O₀-I/O₈ for × 18 devices.
4. A₀-A₁₃ for 16K; A₀-A₁₄ for 32K; A₀-A₁₅ for 64K devices.

Contents

Pin Configurations	3	32 K × 16 3.3 V Synchronous Dual-Port SRAM	18
Selection Guide	5	16 K × 18 3.3 V Synchronous Dual-Port SRAM	18
Pin Definitions	5	64 K × 18 3.3 V Synchronous Dual-Port SRAM	18
Functional Description	6	Ordering Code Definitions	19
Maximum Ratings	7	Package Diagrams	19
Operating Range	7	Acronyms	20
Electrical Characteristics	7	Document Conventions	20
Capacitance	7	Units of Measure	20
AC Test Loads and Waveforms	8	Document History Page	21
Switching Characteristics	9	Sales, Solutions, and Legal Information	22
Switching Waveforms	10	Worldwide Sales and Design Support	22
Read/Write and Enable Operation	17	Products	22
Address Counter Control Operation	17	PSoC Solutions	22
Ordering Information	18		
16 K × 16 3.3 V Synchronous Dual-Port SRAM	18		

Pin Configurations

Figure 1. 100-pin TQFP (Top View)

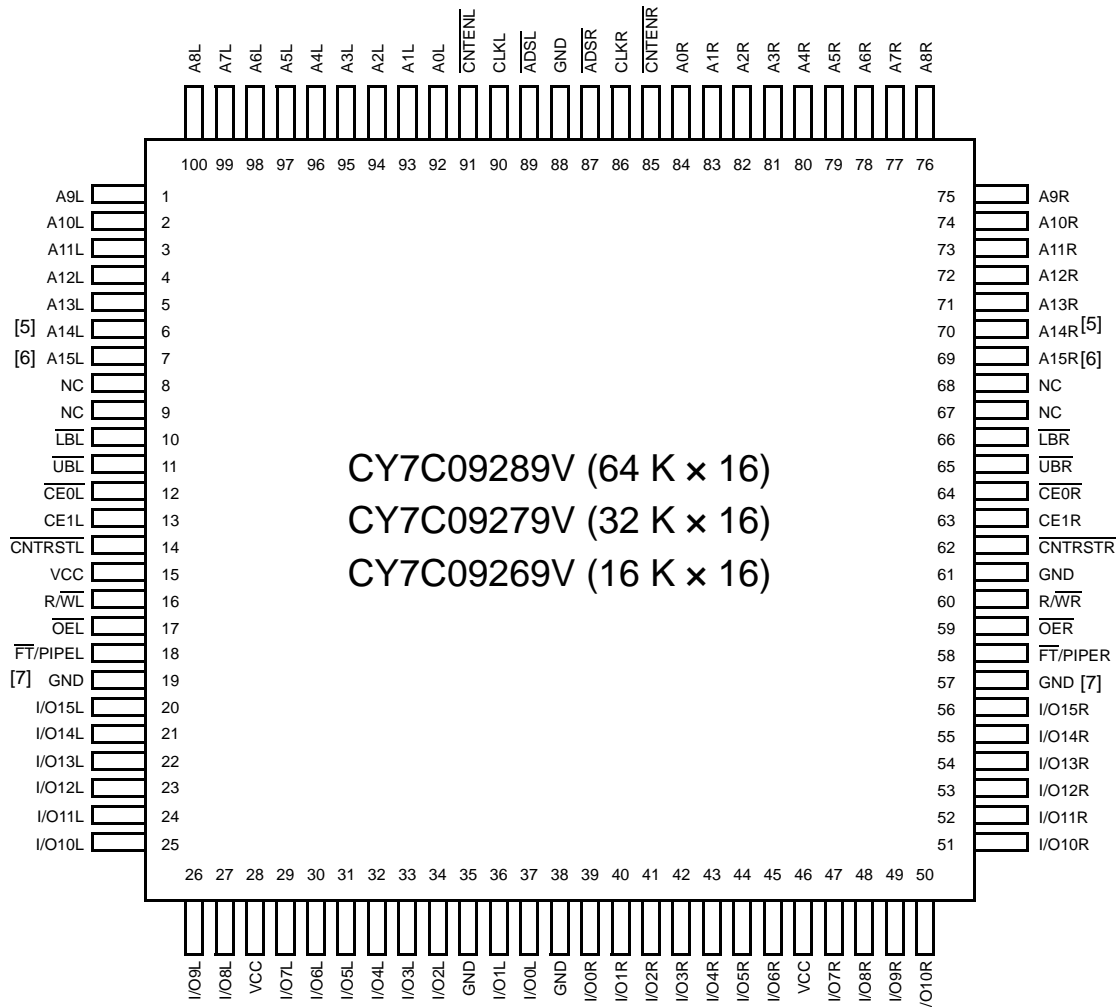

Notes

5. This pin is NC for CY7C09269V.
6. This pin is NC for CY7C09269V and CY7C09279V.
7. For CY7C09269V and CY7C09279V, pin #18 connected to V_{CC} is pin compatible to an IDT 5 V × 16 pipelined device; connecting pin #18 and #58 to GND is pin compatible to an IDT 5 V × 16 flow through device.

Pin Configurations (continued)

Figure 2. 100-pin TQFP (Top View)

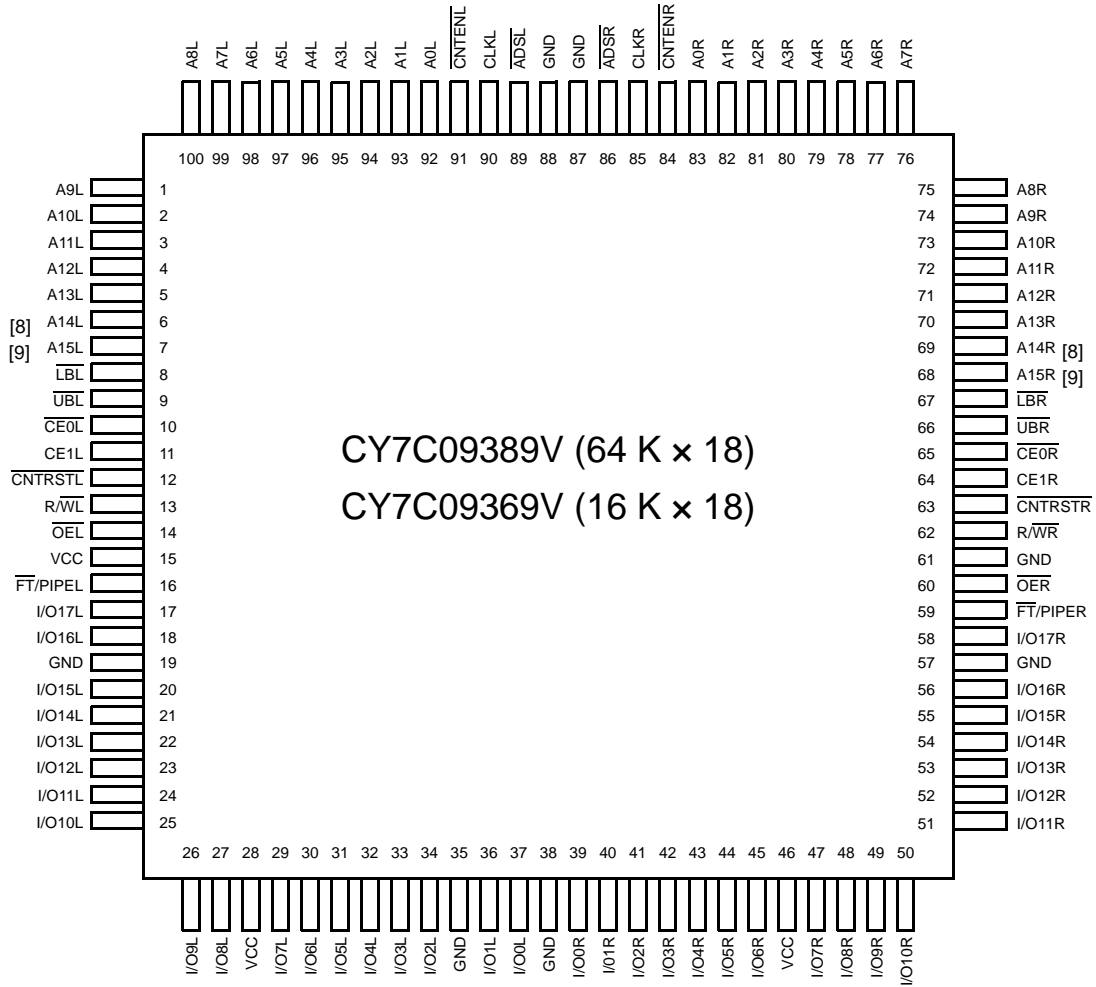

Notes

- 8. This pin is NC for CY7C09369V.
- 9. This pin is NC for CY7C09369V.

Selection Guide

Specifications	CY7C09269V/79V/89V CY7C09369V/89V -7 ^[10]	CY7C09269V/79V/89V CY7C09369V/89V -9	CY7C09269V/79V/89V CY7C09369V/89V -12
f _{MAX2} (MHz) (Pipelined)	83	67	50
Max. Access Time (ns) (Clock to Data, Pipelined)	7.5	9	12
Typical Operating Current I _{CC} (mA)	155	135	115
Typical Standby Current for I _{SB1} (mA) (Both Ports TTL Level)	25	20	20
Typical Standby Current for I _{SB3} (μA) (Both Ports CMOS Level)	10	10	10

Pin Definitions

Left Port	Right Port	Description
A _{0L} -A _{15L}	A _{0R} -A _{15R}	Address Inputs (A ₀ -A ₁₄ for 32K, A ₀ -A ₁₃ for 16K devices).
ADS _L	ADS _R	Address Strobe Input. Used as an address qualifier. This signal must be asserted LOW to access the part using an externally supplied address. Asserting this signal LOW also loads the burst counter with the address present on the address pins.
CE _{0L} , CE _{1L}	CE _{0R} , CE _{1R}	Chip Enable Input. To select either the left or right port, both CE ₀ AND CE ₁ must be asserted to their active states (CE ₀ ≤ V _{IL} and CE ₁ ≥ V _{IH}).
CLK _L	CLK _R	Clock Signal. This input can be free running or strobed. Maximum clock input rate is f _{MAX} .
CNTEN _L	CNTEN _R	Counter Enable Input. Asserting this signal LOW increments the burst address counter of its respective port on each rising edge of CLK. CNTEN is disabled if ADS or CNTRST are asserted LOW.
CNTRST _L	CNTRST _R	Counter Reset Input. Asserting this signal LOW resets the burst address counter of its respective port to zero. CNTRST is not disabled by asserting ADS or CNTEN.
I/O _{0L} -I/O _{17L}	I/O _{0R} -I/O _{17R}	Data Bus Input/Output (I/O ₀ -I/O ₁₅ for × 16 devices).
LB _L	LB _R	Lower Byte Select Input. Asserting this signal LOW enables read and write operations to the lower byte. (I/O ₀ -I/O ₈ for × 18, I/O ₀ -I/O ₇ for × 16) of the memory array. For read operations both the LB and OE signals must be asserted to drive output data on the lower byte of the data pins.
UB _L	UB _R	Upper Byte Select Input. Same function as LB, but to the upper byte (I/O _{8/9L} -I/O _{15/17L}).
OE _L	OE _R	Output Enable Input. This signal must be asserted LOW to enable the I/O data pins during read operations.
R/W _L	R/W _R	Read/Write Enable Input. This signal is asserted LOW to write to the dual port memory array. For read operations, assert this pin HIGH.
FT/PIPE _L	FT/PIPE _R	Flow Through/Pipelined Select Input. For flow through mode operation, assert this pin LOW. For pipelined mode operation, assert this pin HIGH.
GND		Ground Input.
NC		No Connect.
V _{CC}		Power Input.

Note

10. See [Figure 4 on page 8](#) for Load Conditions.

Functional Description

The CY7C09269V/79V/89V and CY7C09369V/89V are high speed 3.3 V synchronous CMOS 16 K, 32 K, and 64 K × 16 and 16 K and 64 K × 18 dual-port static RAMs. Two ports are provided, permitting independent, simultaneous access for reads and writes to any location in memory ^[11]. Registers on control, address, and data lines allow for minimal setup and hold times. In pipelined output mode, data is registered for decreased cycle time and clock to data valid $t_{CD2} = 7.5 \text{ ns}$ ^[12] (pipelined). Flow through mode can also be used to bypass the pipelined output register to eliminate access latency. In flow through mode, data is available $t_{CD1} = 18 \text{ ns}$ after the address is clocked into the device. Pipelined output or flow through mode is selected through the FT/Pipe pin.

Each port contains a burst counter on the input address register. The internal write pulse width is independent of the LOW to HIGH transition of the clock signal. The internal write pulse is self timed to allow the shortest possible cycle times.

A HIGH on \overline{CE}_0 or LOW on CE_1 for one clock cycle powers down the internal circuitry to reduce the static power consumption. The use of multiple Chip Enables enables easier banking of multiple chips for depth expansion configurations. In the pipelined mode, one cycle is required with \overline{CE}_0 LOW and CE_1 HIGH to reactivate the outputs.

Counter enable inputs are provided to stall the operation of the address input and use the internal address generated by the internal counter for fast interleaved memory applications. A port's burst counter is loaded with the port's Address Strobe (ADS). When the port's Count Enable (CNTEN) is asserted, the address counter increments on each LOW to HIGH transition of that port's clock signal. This reads/writes one word from or into each successive address location, until CNTEN is deasserted. The counter can address the entire memory array and loop back to the start. Counter Reset (CNTRST) is used to reset the burst counter.

All parts are available in 100-pin Thin Quad Plastic Flatpack (TQFP) packages.

Notes

11. When writing simultaneously to the same location, the final value cannot be guaranteed.
12. See [Figure 4 on page 8](#) for Load Conditions.

Maximum Ratings

Exceeding maximum ratings ^[13] may impair the useful life of the device. These user guidelines are not tested.

Storage Temperature	-65 °C to +150 °C
Ambient Temperature with Power Applied	-55 °C to +125 °C
Supply Voltage to Ground Potential	-0.5 V to +4.6 V
DC Voltage Applied to Outputs in High Z State	-0.5 V to V _{CC} + 0.5 V

DC Input Voltage	-0.5 V to V _{CC} + 0.5 V
Output Current into Outputs (LOW)	20 mA
Static Discharge Voltage (per MIL-STD-883, Method 3015)	> 1100 V
Latch up Current	> 200 mA

Operating Range

Range	Ambient Temperature	V _{CC}
Commercial	0 °C to +70 °C	3.3 V ± 300 mV
Industrial	-40 °C to +85 °C	3.3 V ± 300 mV

Electrical Characteristics

Over the Operating Range

Parameter	Description	CY7C09269V/79V/89V CY7C09369V/89V									Unit	
		-7 ^[14]			-9			-12				
		Min	Typ	Max	Min	Typ	Max	Min	Typ	Max		
V _{OH}	Output HIGH Voltage (V _{CC} = Min, I _{OH} = -4.0 mA)	2.4	-	-	2.4	-	-	2.4	-	-	V	
V _{OL}	Output LOW Voltage (V _{CC} = Min, I _{OH} = +4.0 mA)	-	-	0.4	-	-	0.4	-	-	0.4	V	
V _{IH}	Input HIGH Voltage	2.0	-	-	2.0	-	-	2.0	-	-	V	
V _{IL}	Input LOW Voltage	-	-	0.8	-	-	0.8	-	-	0.8	V	
I _{OZ}	Output Leakage Current	-10	-	10	-10	-	10	-10	-	10	µA	
I _{CC}	Operating Current (V _{CC} = Max, I _{OUT} = 0 mA) Outputs Disabled	Commercial	-	155	275	-	135	230	-	115	180	mA
		Industrial	-	275	390	-	185	300	-	-	-	mA
I _{SB1}	Standby Current (Both Ports TTL Level) ^[15] CE _L & CE _R ≥ V _{IH} , f = f _{MAX}	Commercial	-	25	85	-	20	75	-	20	70	mA
		Industrial	-	85	120	-	35	85	-	-	-	mA
I _{SB2}	Standby Current (One Port TTL Level) ^[15] CE _L CE _R ≥ V _{IH} , f = f _{MAX}	Commercial	-	105	165	-	95	155	-	85	140	mA
		Industrial	-	165	210	-	105	165	-	-	-	mA
I _{SB3}	Standby Current (Both Ports CMOS Level) ^[15] CE _L & CE _R ≥ V _{CC} - 0.2 V, f = 0	Commercial	-	10	250	-	10	250	-	10	250	µA
		Industrial	-	10	250	-	10	250	-	-	-	µA
I _{SB4}	Standby Current (One Port CMOS Level) ^[15] CE _L CE _R ≥ V _{IH} , f = f _{MAX}	Commercial	-	95	125	-	85	115	-	75	100	mA
		Industrial	-	125	170	-	95	125	-	-	-	mA

Capacitance

Parameter ^[16]	Description	Test Conditions	Max	Unit
C _{IN}	Input Capacitance	T _A = 25 °C, f = 1 MHz, V _{CC} = 3.3 V	10	pF
C _{OUT}	Output Capacitance		10	pF

Notes

13. The voltage on any input or I/O pin can not exceed the power pin during power up.

14. See Figure 4 on page 8 for Load Conditions.

15. CE_L and CE_R are internal signals. To select either the left or right port, both CE₀ and CE₁ must be asserted to their active states (CE₀ ≤ V_{IL} and CE₁ ≥ V_{IH}).

16. Tested initially and after any design or process changes that may affect these parameters.

AC Test Loads and Waveforms

Figure 3. AC Test Loads and Waveforms

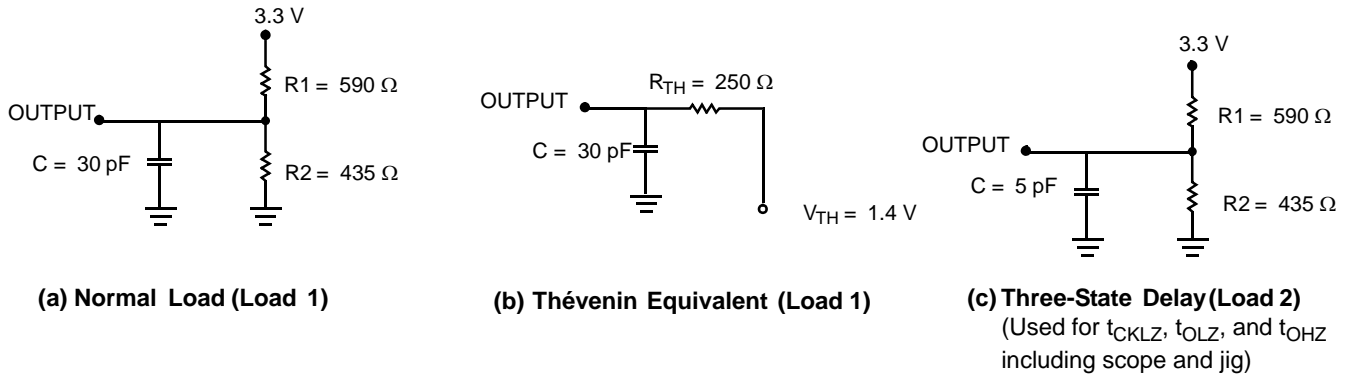
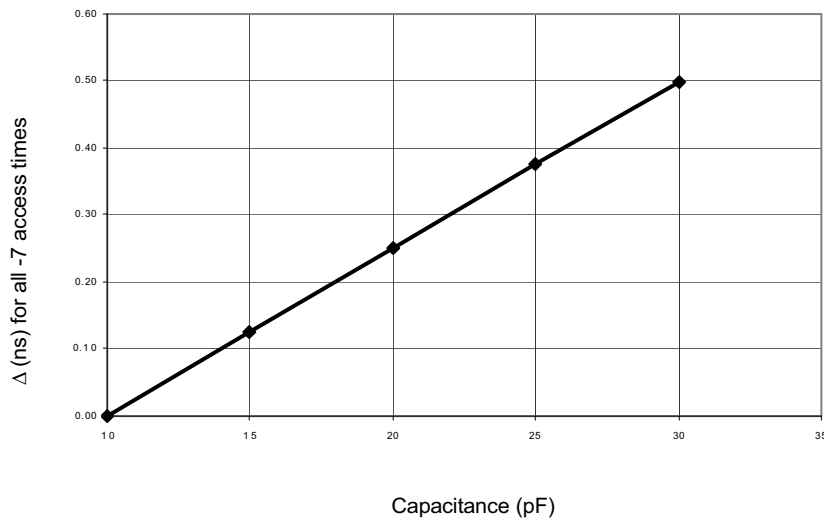
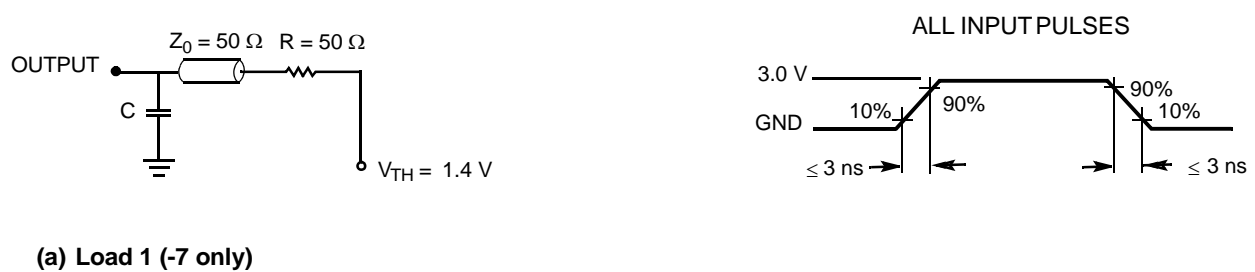

Figure 4. AC Test Loads (Applicable to -7 only) ^[17]



(b) Load Derating Curve

Note
17. Test Conditions: C = 10 pF.

Switching Characteristics

Over the Operating Range

Parameter	Description	CY7C09269V/79V/89V CY7C09369V/89V						Unit
		-7 ^[18]		-9		-12		
		Min	Max	Min	Max	Min	Max	
f _{MAX1}	f _{Max} Flow Through	–	45	–	40	–	33	MHz
f _{MAX2}	f _{Max} Pipelined	–	83	–	67	–	50	MHz
t _{CYC1}	Clock Cycle Time - Flow Through	22	–	25	–	30	–	ns
t _{CYC2}	Clock Cycle Time - Pipelined	12	–	15	–	20	–	ns
t _{CH1}	Clock HIGH Time - Flow Through	7.5	–	12	–	12	–	ns
t _{CL1}	Clock LOW Time - Flow Through	7.5	–	12	–	12	–	ns
t _{CH2}	Clock HIGH Time - Pipelined	5	–	6	–	8	–	ns
t _{CL2}	Clock LOW Time - Pipelined	5	–	6	–	8	–	ns
t _R	Clock Rise Time	–	3	–	3	–	3	ns
t _F	Clock Fall Time	–	3	–	3	–	3	ns
t _{SA}	Address Set-Up Time	4	–	4	–	4	–	ns
t _{HA}	Address Hold Time	0	–	1	–	1	–	ns
t _{SC}	Chip Enable Setup Time	4	–	4	–	4	–	ns
t _{HC}	Chip Enable Hold Time	0	–	1	–	1	–	ns
t _{SW}	R/W Set-Up Time	4	–	4	–	4	–	ns
t _{HW}	R/W Hold Time	0	–	1	–	1	–	ns
t _{SD}	Input Data Setup Time	4	–	4	–	4	–	ns
t _{HD}	Input Data Hold Time	0	–	1	–	1	–	ns
t _{SAD}	ADS Set-Up Time	4	–	4	–	4	–	ns
t _{HAD}	ADS Hold Time	0	–	1	–	1	–	ns
t _{SCN}	CNTEN Setup Time	4.5	–	5	–	5	–	ns
t _{HCN}	CNTEN Hold Time	0	–	1	–	1	–	ns
t _{SRST}	CNTRST Setup Time	4	–	4	–	4	–	ns
t _{HRST}	CNTRST Hold Time	0	–	1	–	1	–	ns
t _{OE}	Output Enable to Data Valid	–	9	–	10	–	12	ns
t _{OLZ} ^[19, 20]	OE to Low Z	2	–	2	–	2	–	ns
t _{OHZ} ^[19, 20]	OE to High Z	1	7	1	7	1	7	ns
t _{CD1}	Clock to Data Valid - Flow Through	–	18	–	20	–	25	ns
t _{CD2}	Clock to Data Valid - Pipelined	–	7.5	–	9	–	12	ns
t _{DC}	Data Output Hold After Clock HIGH	2	–	2	–	2	–	ns
t _{CKHZ} ^[19, 20]	Clock HIGH to Output High Z	2	9	2	9	2	9	ns
t _{CKLZ} ^[19, 20]	Clock HIGH to Output Low Z	2	–	2	–	2	–	ns
Port to Port Delays								
t _{CWDD}	Write Port Clock HIGH to Read Data Delay	–	35	–	40	–	40	ns
t _{CCS}	Clock to Clock Setup Time	–	10	–	15	–	15	ns

Notes

- 18. See Figure 4 on page 8 for Load Conditions.
- 19. Test conditions used are Load 2.
- 20. This parameter is guaranteed by design, but it is not production tested.

Switching Waveforms

Figure 5. Read Cycle for Flow Through Output (FT/PIPE = V_{IL}) [21, 22, 23, 24]

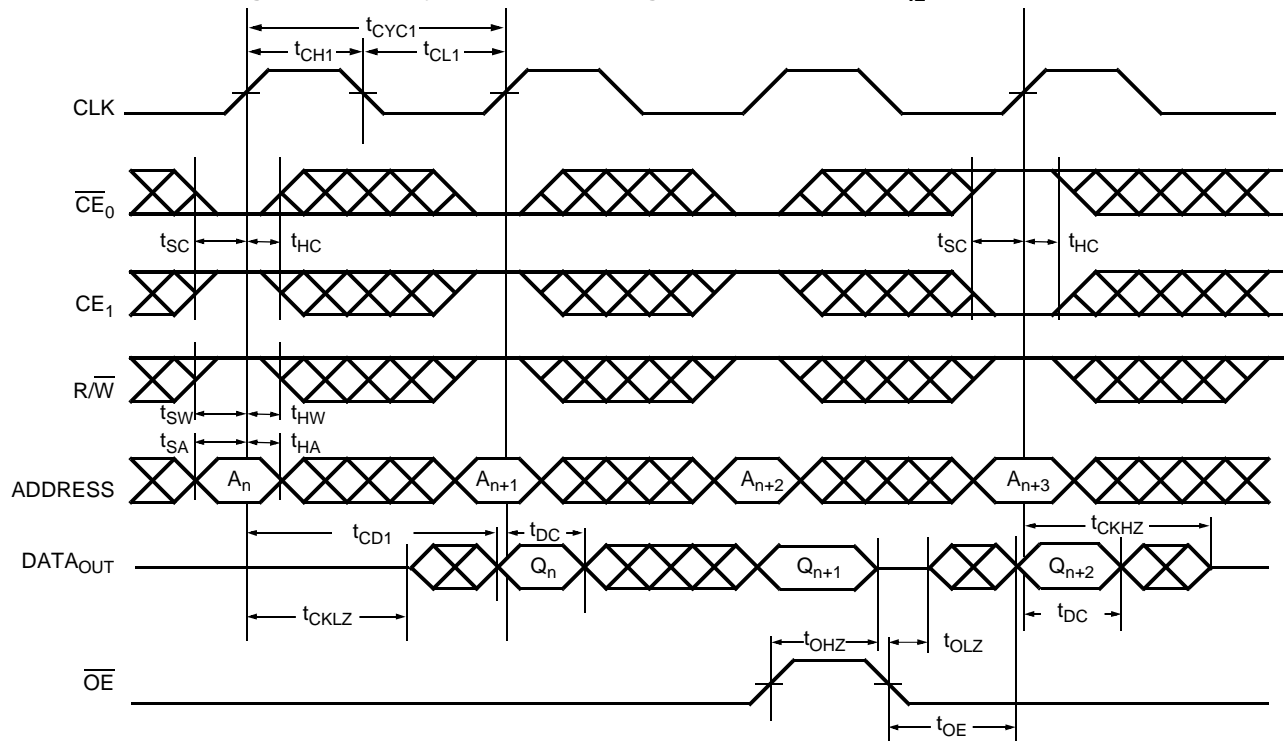
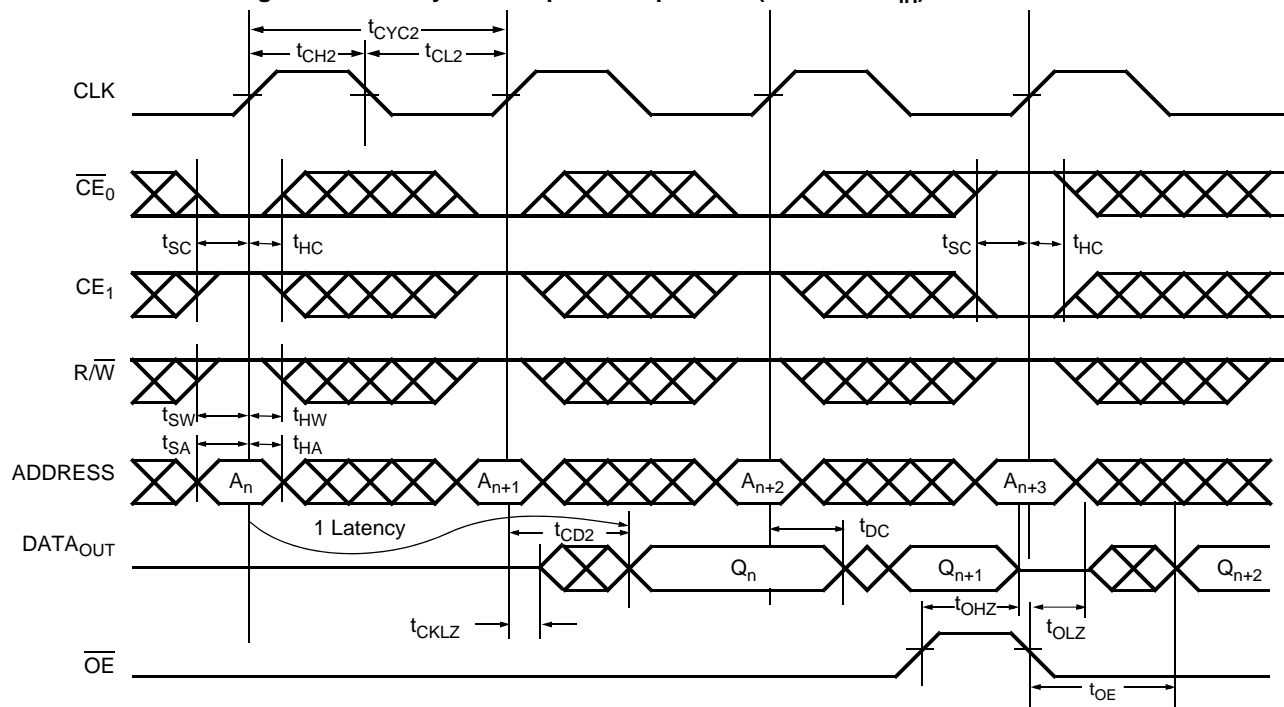

Figure 6. Read Cycle for Pipelined Operation (FT/PIPE = V_{IH}) [21, 22, 23, 24]



Notes

21. \overline{OE} is asynchronously controlled; all other inputs are synchronous to the rising clock edge.

22. $\overline{ADS} = V_{IL}$, \overline{CNTEN} and $\overline{CNTRST} = V_{IH}$.

23. The output is disabled (high impedance state) by $\overline{CE}_0 = V_{IH}$ or $\overline{CE}_1 = V_{IL}$ following the next rising edge of the clock.

24. Addresses do not have to be accessed sequentially since $\overline{ADS} = V_{IL}$ constantly loads the address on the rising edge of the CLK. Numbers are for reference only.

Switching Waveforms (continued)

Figure 7. Bank Select Pipelined Read [25, 26]

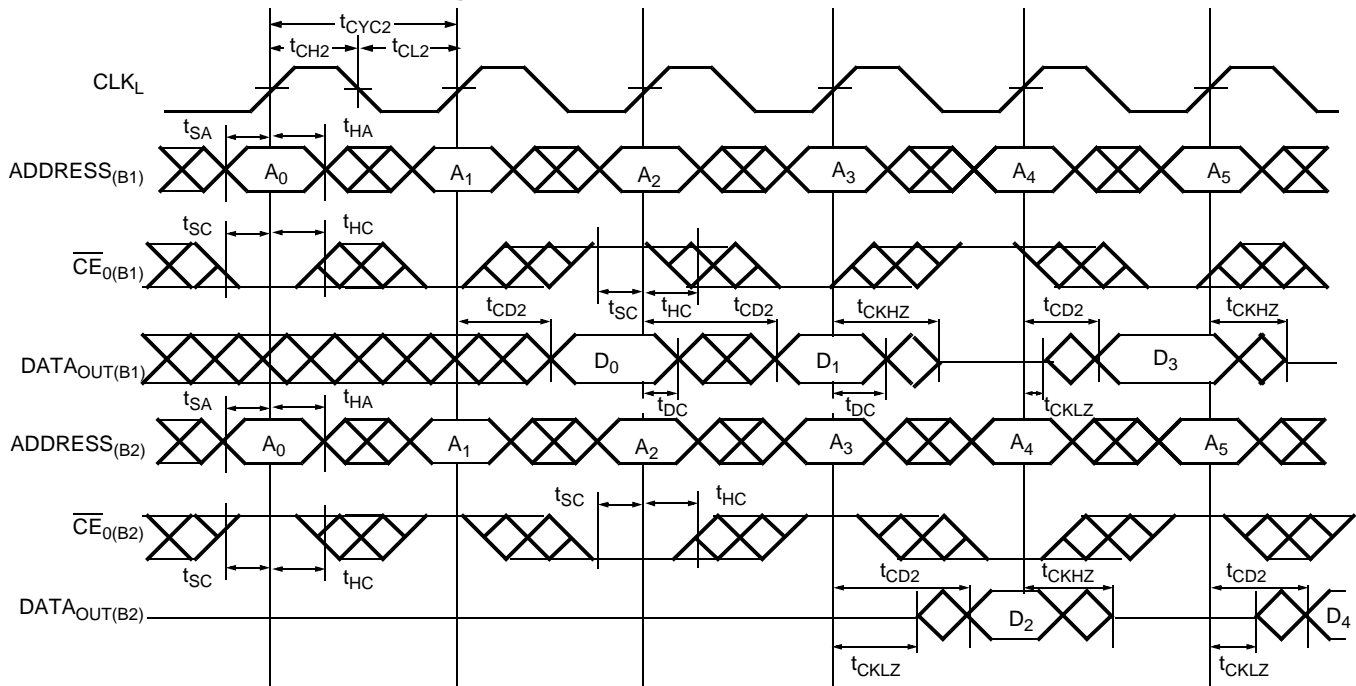
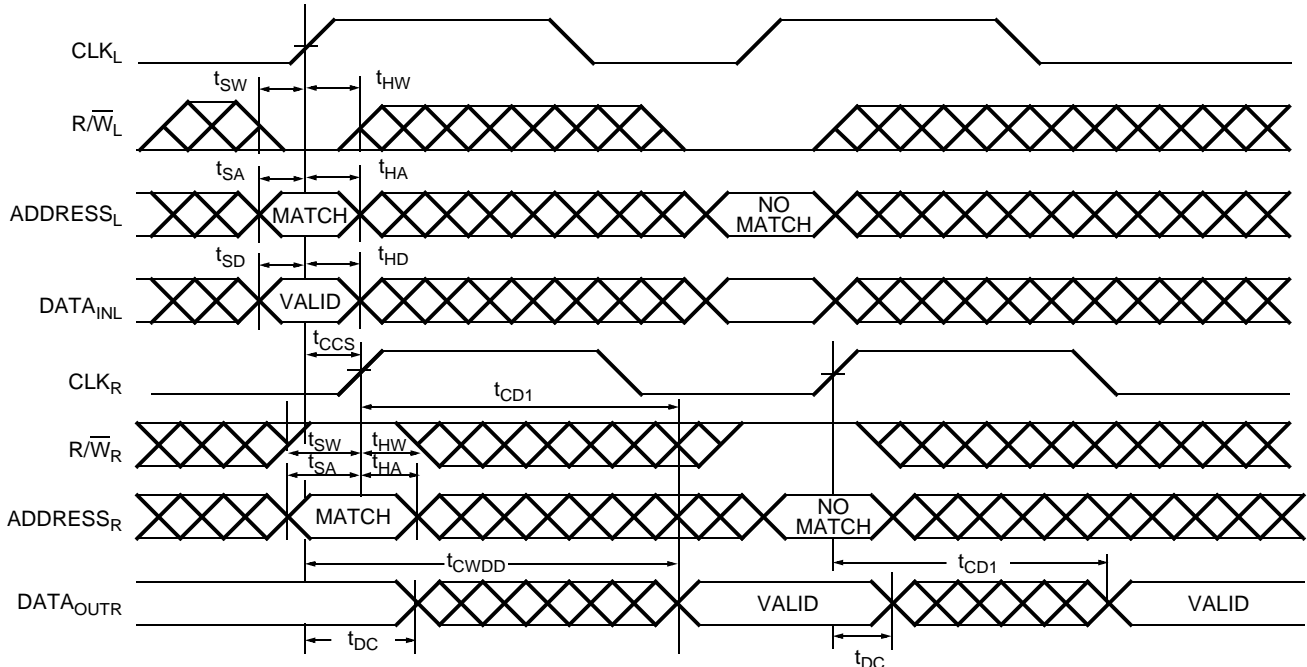

Figure 8. Left Port Write to Flow Through Right Port Read [27, 28, 29, 30]



Notes

25. In this depth expansion example, B1 represents Bank #1 and B2 is Bank #2; Each Bank consists of one Cypress dual-port device from this datasheet. ADDRESS_(B1) = ADDRESS_(B2).
26. \overline{UB} , \overline{LB} , \overline{OE} and $\overline{ADS} = V_{IL}$; $\overline{CE}_{1(B1)}$, $\overline{CE}_{1(B2)}$, R/\overline{W} , \overline{CNTEN} , and $\overline{CNTRST} = V_{IH}$.
27. The same waveforms apply for a right port write to flow through left port read.
28. \overline{CE}_0 , \overline{UB} , \overline{LB} , and $\overline{ADS} = V_{IL}$; \overline{CE}_1 , \overline{CNTEN} , and $\overline{CNTRST} = V_{IH}$.
29. $\overline{OE} = V_{IL}$ for the Right Port, which is being read from. $\overline{OE} = V_{IH}$ for the Left Port, which is being written to.
30. If $t_{CCS} \leq$ maximum specified, then data from right port READ is not valid until the maximum specified for t_{CWDD} . If $t_{CCS} >$ maximum specified, then data is not valid until $t_{CCS} + t_{CD1}$. t_{CWDD} does not apply in this case.

Switching Waveforms (continued)

Figure 9. Pipelined Read-to-Write-to-Read ($\overline{OE} = V_{IL}$) [31, 32, 33, 34]

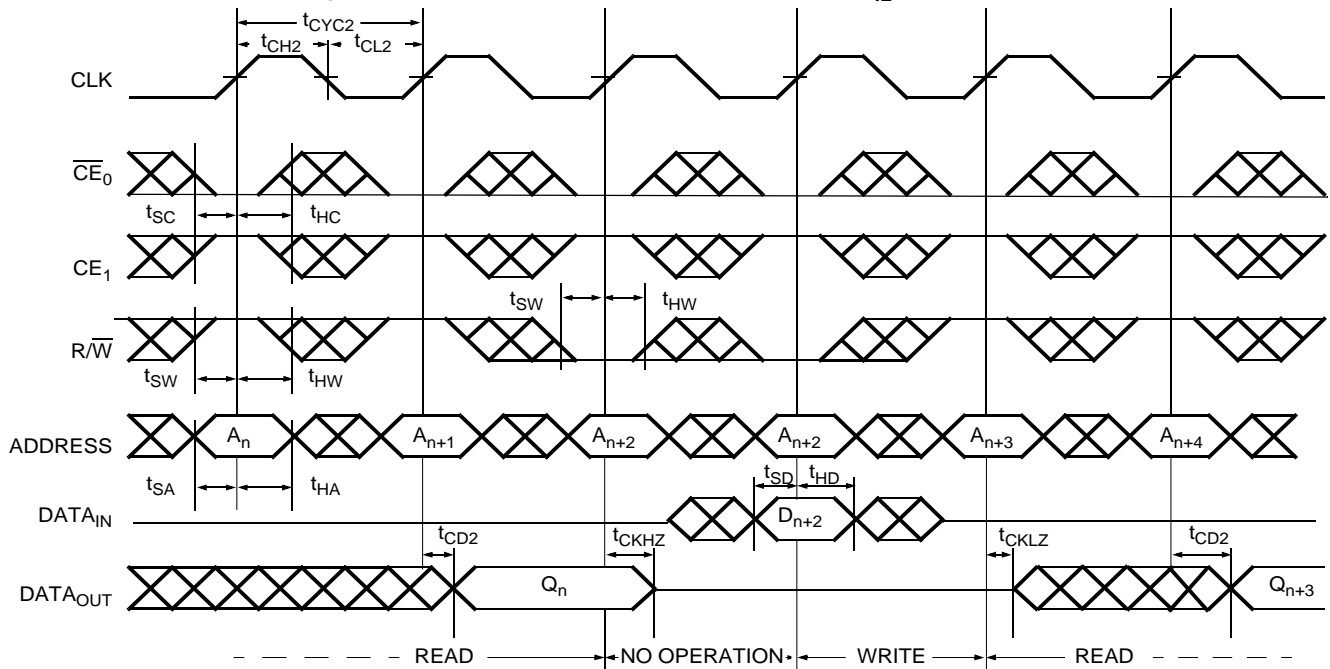
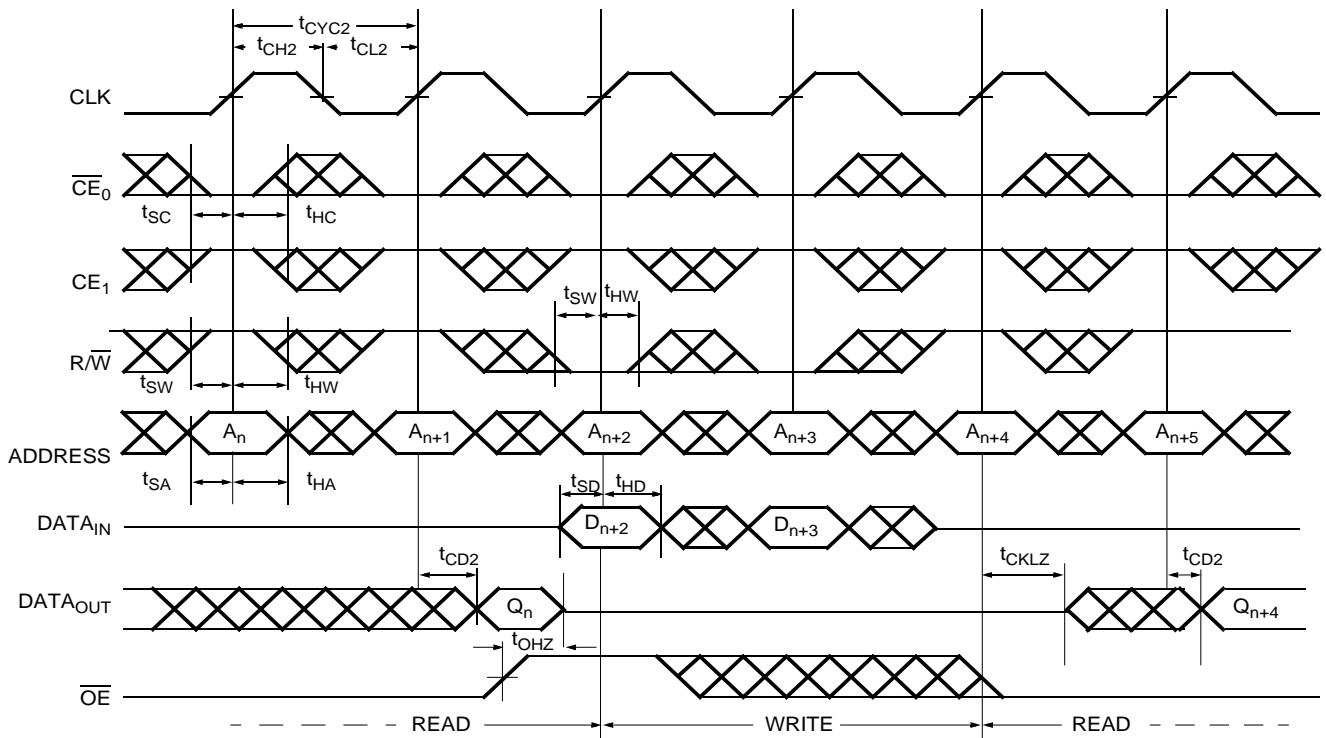

Figure 10. Pipelined Read-to-Write-to-Read (\overline{OE} Controlled) [31, 32, 33, 34]



Notes

- 31. Addresses do not have to be accessed sequentially since $\overline{ADS} = V_{IL}$ constantly loads the address on the rising edge of the CLK. Numbers are for reference only.
- 32. Output state (High, LOW, or high impedance) is determined by the previous cycle control signals.
- 33. \overline{CE}_0 and $\overline{ADS} = V_{IL}$; CE_1 , \overline{CNTEN} , and $\overline{CNRST} = V_{IH}$.
- 34. During "No Operation", data in memory at the selected address may be corrupted and must be rewritten to ensure data integrity.

Switching Waveforms (continued)

Figure 11. Flow Through Read-to-Write-to-Read ($\overline{OE} = V_{IL}$) [35, 36, 37, 38]

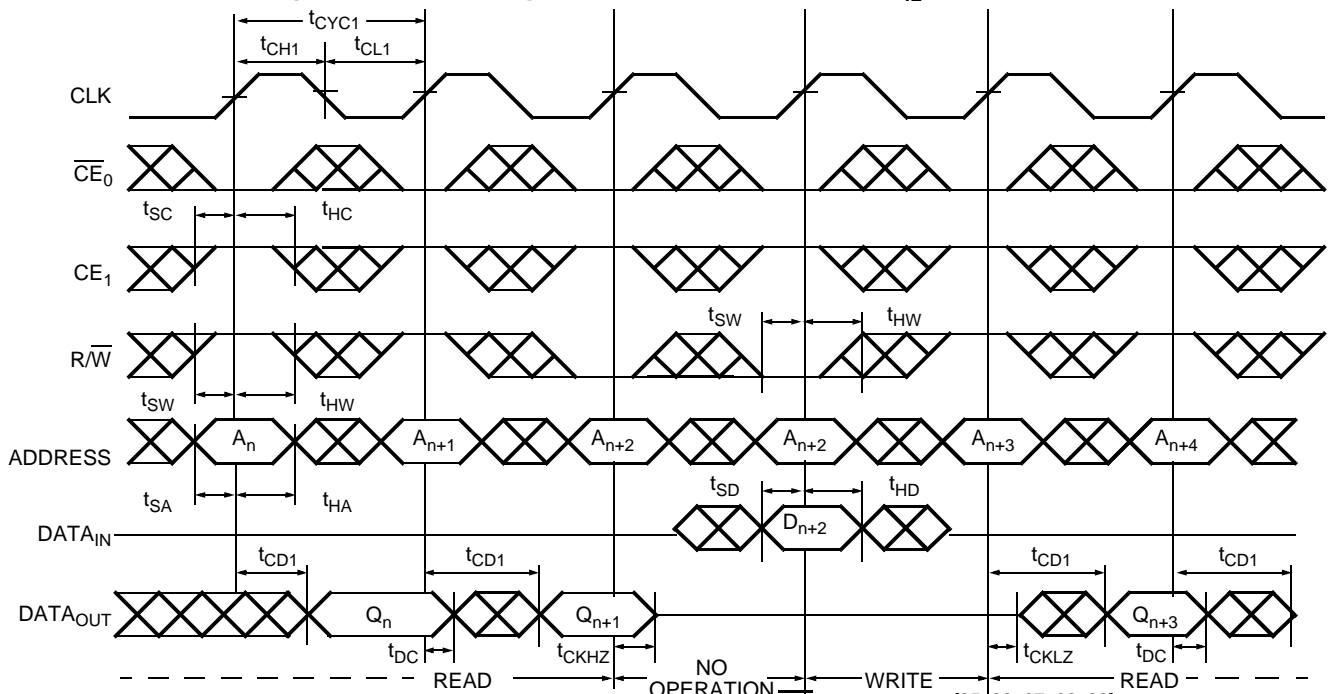
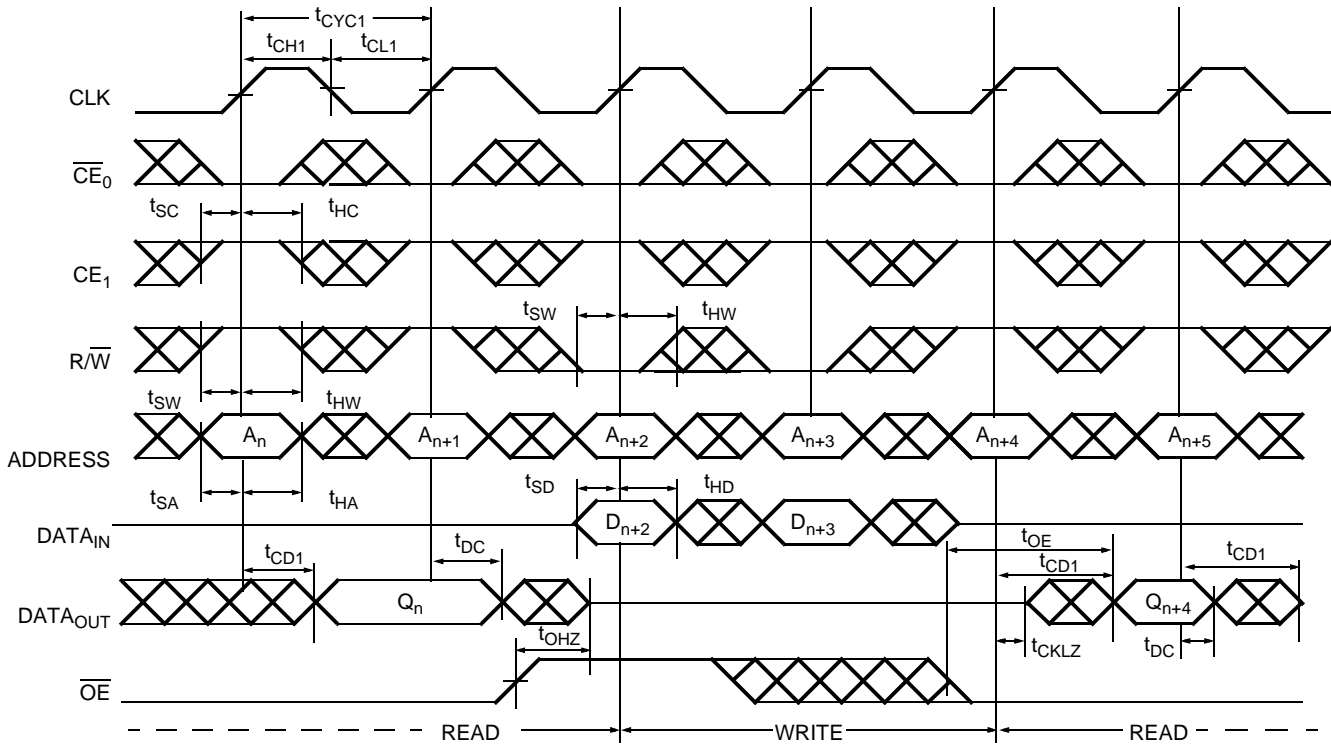

Figure 12. Flow Through Read-to-Write-to-Read (\overline{OE} Controlled) [35, 36, 37, 38, 39]



Notes

- 35. $ADS = V_{IL}$, $CNTEN$ and $CNTRST = V_{IH}$.
- 36. Addresses do not have to be accessed sequentially since $\overline{ADS} = V_{IL}$ constantly loads the address on the rising edge of the CLK. Numbers are for reference only.
- 37. \overline{CE}_0 and $ADS = V_{IL}$; CE_1 , $CNTEN$, and $CNTRST = V_{IH}$.
- 38. During "No Operation", data in memory at the selected address may be corrupted and must be rewritten to ensure data integrity.
- 39. Output state (High, LOW, or high impedance) is determined by the previous cycle control signals.

Switching Waveforms (continued)

Figure 13. Pipelined Read with Address Counter Advance [40]

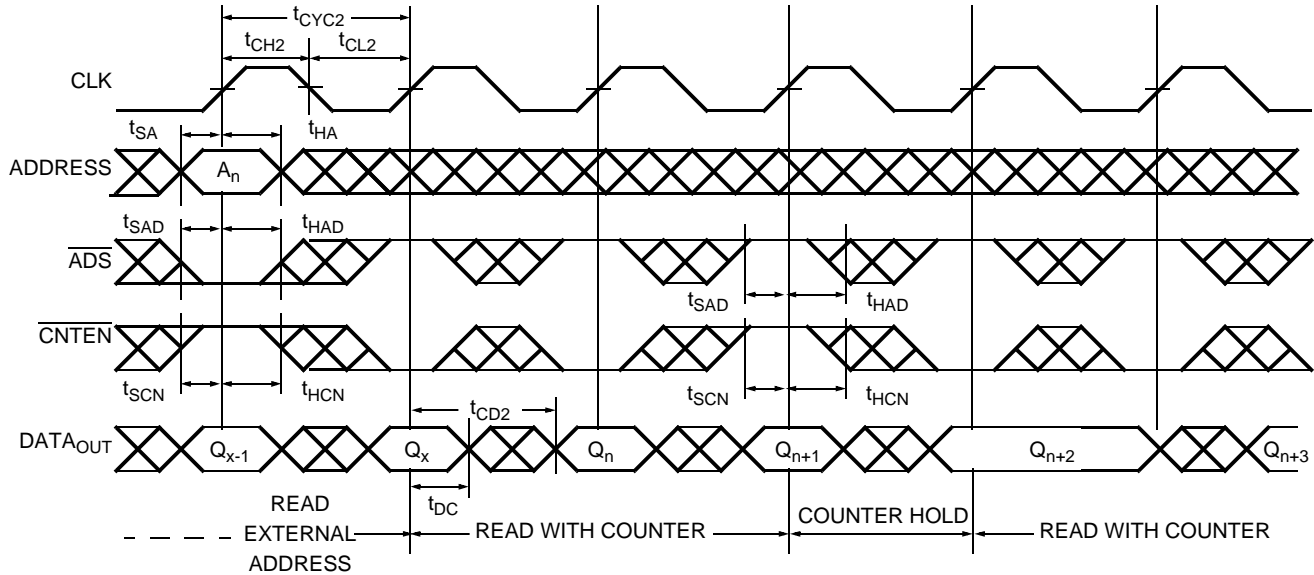
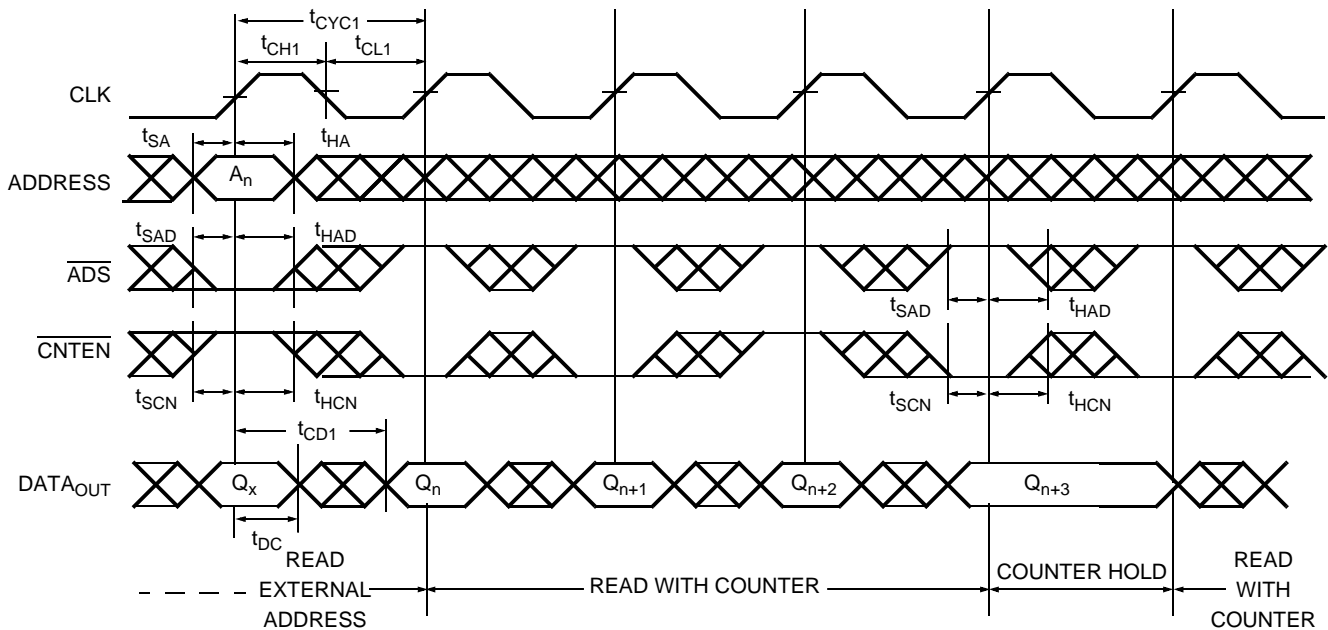

Figure 14. Flow Through Read with Address Counter Advance [40]



Note

40. $\overline{CE_0}$ and $\overline{OE} = V_{IL}$; CE_1 , R/\overline{W} and $\overline{CNRST} = V_{IH}$.

Switching Waveforms (continued)

Figure 15. Write with Address Counter Advance (Flow Through or Pipelined Outputs) [41, 42]

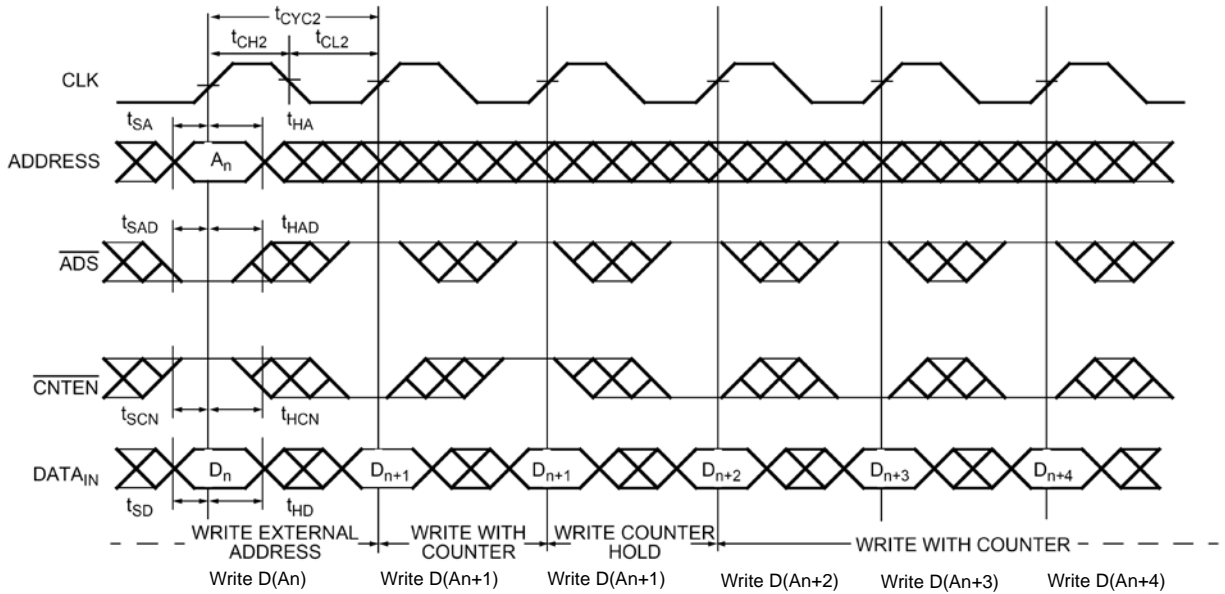

Notes

41. \overline{CE}_0 , \overline{UB} , \overline{LB} , and $\overline{R/\overline{W}} = V_{IL}$; \overline{CE}_1 and $\overline{CNTRST} = V_{IH}$.

42. The "Internal Address" is equal to the "External Address" when $\overline{ADS} = V_{IL}$ and equals the counter output when $\overline{ADS} = V_{IH}$.

Switching Waveforms (continued)

Figure 16. Counter Reset (Pipelined Outputs) [43, 44, 45, 46]

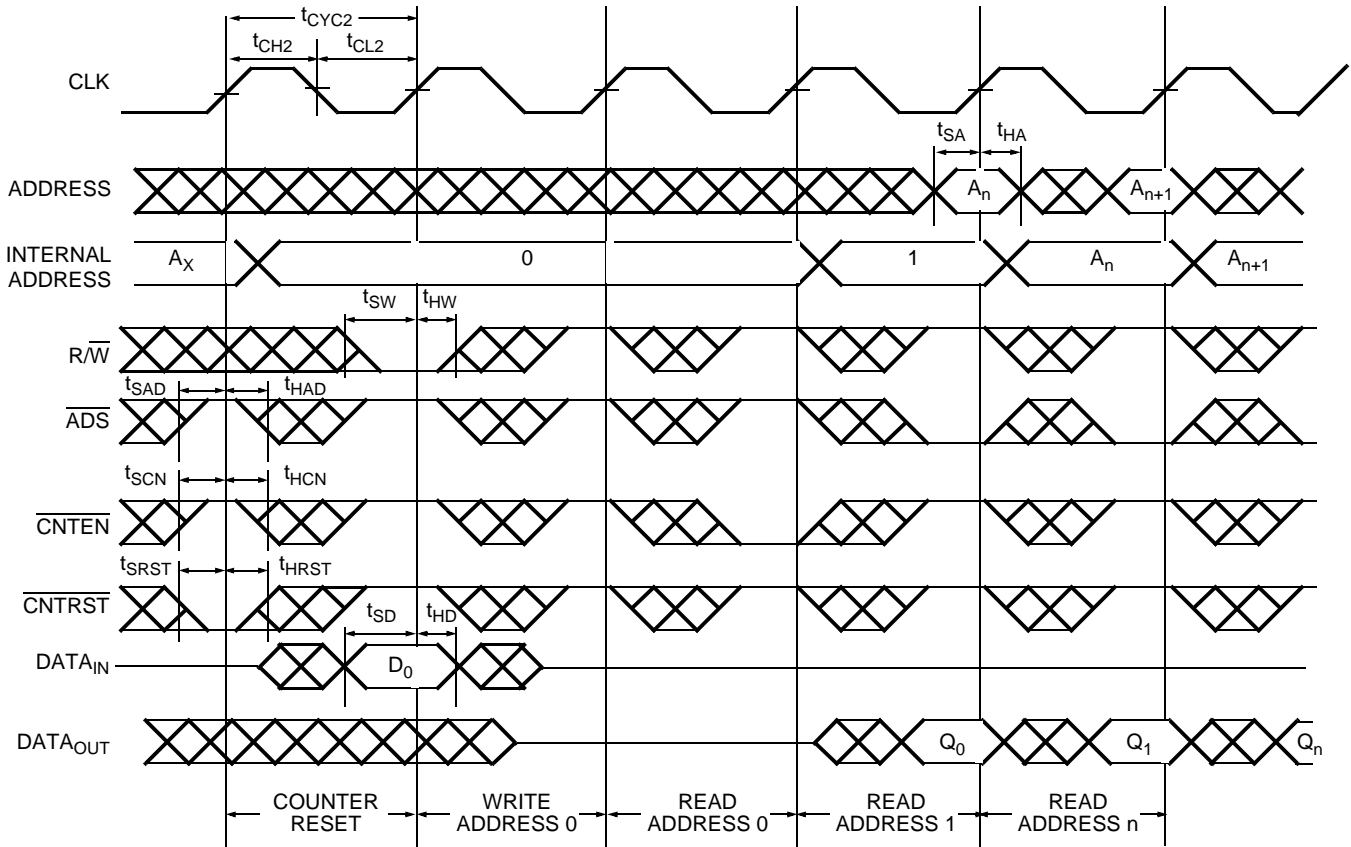





Notes

43. Addresses do not have to be accessed sequentially since $\overline{ADS} = V_{IL}$ constantly loads the address on the rising edge of the CLK. Numbers are for reference only.
44. Output state (High, LOW, or high impedance) is determined by the previous cycle control signals.
45. \overline{CE}_0 , UB, and LB = V_{IL} ; $CE_1 = V_{IH}$.
46. No dead cycle exists during counter reset. A READ or WRITE cycle may be coincidental with the counter reset.





Read/Write and Enable Operation

The Read/Write and Enable Operation is described as follows. [47, 48, 49]

Inputs					Outputs	Operation
OE	CLK	CE ₀	CE ₁	R/W	I/O ₀ –I/O ₁₇	
X		H	X	X	High Z	Deselected [50]
X		X	L	X	High Z	Deselected [50]
X		L	H	L	D _{IN}	Write
L		L	H	H	D _{OUT}	Read [51]
H	X	L	H	X	High Z	Outputs Disabled

Address Counter Control Operation

The Address Counter Control Operation is described as follows. [47, 52, 53, 54]

Address	Previous Address	CLK	ADS	CNTEN	CNTRST	I/O	Mode	Operation
X	X		X	X	L	D _{out(0)}	Reset	Counter Reset to Address 0
A _n	X		L	X	H	D _{out(n)}	Load	Address Load into Counter
X	A _n		H	H	H	D _{out(n)}	Hold	External Address Blocked — Counter Disabled
X	A _n		H	L	H	D _{out(n+1)}	Increment	Counter Enabled — Internal Address Generation

Notes

47. "X" = "Don't Care", "H" = V_{IH}, "L" = V_{IL}.
48. ADS, CNTEN, CNTRST = "Don't Care".
49. OE is an asynchronous input signal.
50. When CE changes state in the pipelined mode, deselection and read happen in the following clock cycle.
51. ADS = V_{IL}, CNTEN and CNTRST = V_{IH}.
52. CE₀ and OE = V_{IL}; CE₁ and R/W = V_{IH}.
53. Data shown for flow through mode; pipelined mode output is delayed by one cycle.
54. Counter operation is independent of CE₀ and CE₁.

Ordering Information

16 K × 16 3.3 V Synchronous Dual-Port SRAM

Speed (ns)	Ordering Code	Package Diagram	Package Type	Operating Range
7.5 ^[55]	CY7C09269V-7AXC	51-85048	100-pin TQFP (Pb-free)	Commercial
9	CY7C09269V-9AXC	51-85048	100-pin TQFP (Pb-free)	Commercial
12	CY7C09269V-12AXC	51-85048	100-pin TQFP (Pb-free)	Commercial

32 K × 16 3.3 V Synchronous Dual-Port SRAM

Speed (ns)	Ordering Code	Package Diagram	Package Type	Operating Range
7.5 ^[55]	CY7C09279V-7AXC	51-85048	100-pin TQFP (Pb-free)	Commercial
12	CY7C09279V-12AXC	51-85048	100-pin TQFP (Pb-free)	Commercial

64 K × 16 3.3 V Synchronous Dual-Port SRAM

Speed (ns)	Ordering Code	Package Diagram	Package Type	Operating Range
9	CY7C09289V-9AXC	51-85048	100-pin TQFP (Pb-free)	Commercial
	CY7C09289V-9AXI	51-85048	100-pin TQFP (Pb-free)	Industrial
12	CY7C09289V-12AXC	51-85048	100-pin TQFP (Pb-free)	Commercial

16 K × 18 3.3 V Synchronous Dual-Port SRAM

Speed (ns)	Ordering Code	Package Diagram	Package Type	Operating Range
9	CY7C09369V-9AXC	51-85048	100-pin TQFP (Pb-free)	Commercial
12	CY7C09369V-12AXC	51-85048	100-pin TQFP (Pb-free)	Commercial

64 K × 18 3.3 V Synchronous Dual-Port SRAM

Speed (ns)	Ordering Code	Package Diagram	Package Type	Operating Range
7.5 ^[55]	CY7C09389V-7AXC	51-85048	100-pin TQFP (Pb-free)	Commercial
9	CY7C09389V-9AI	51-85048	100-pin TQFP	Industrial

Note

55. See page 6 for Load Conditions.

Ordering Code Definitions

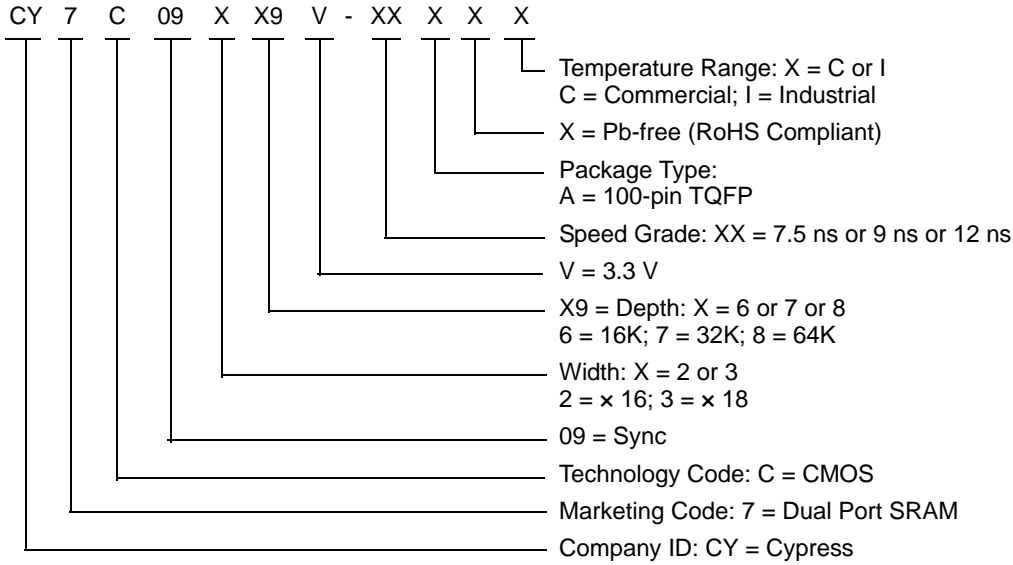

Package Diagrams

Figure 17. 100-pin TQFP (14 x 14 x 1.4 mm) A100SA Package Outline, 51-85048

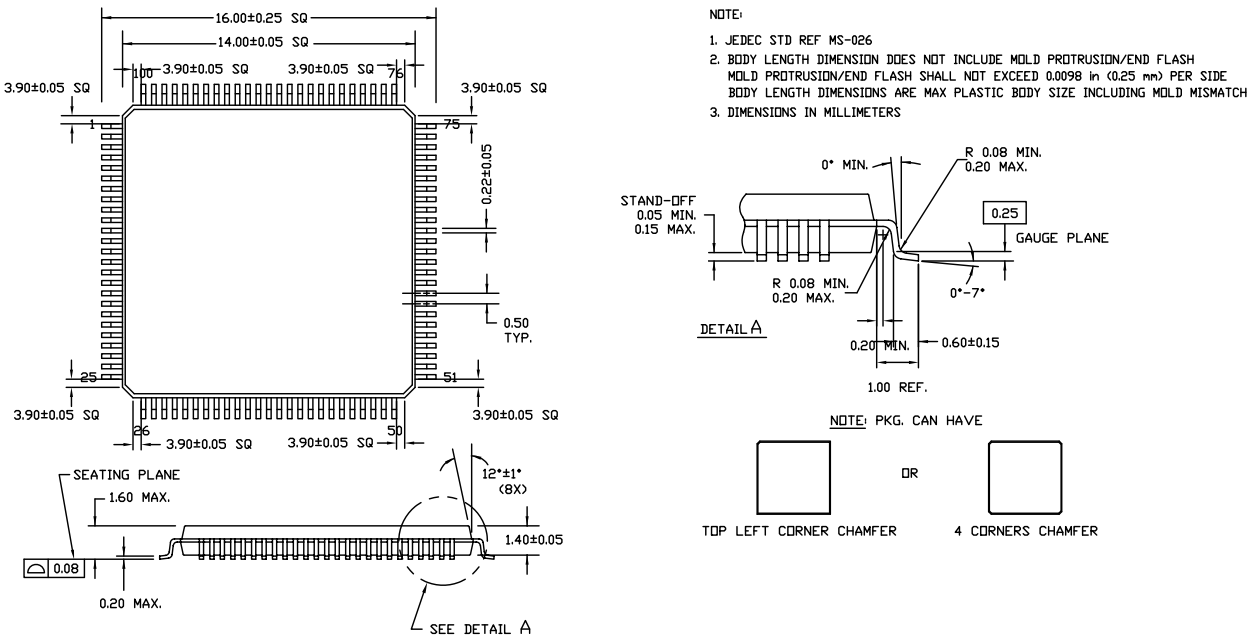

Acronyms

Acronym	Description
\overline{CE}	chip enable
CMOS	complementary metal oxide semiconductor
I/O	input/output
\overline{OE}	output enable
SRAM	static random access memory
TQFP	thin quad flat pack
TTL	transistor-transistor logic

Document Conventions

Units of Measure

Symbol	Unit of Measure
$^{\circ}\text{C}$	degree Celsius
MHz	megahertz
μA	microampere
mA	milliampere
mm	millimeter
mV	millivolt
ns	nanosecond
Ω	ohm
%	percent
pF	picofarad
V	volt

Document History Page

Document Title: CY7C09269V/79V/89V/CY7C09369V/89V, 3.3 V 16 K / 32 K / 64 K x 16 / 18 Synchronous Dual-Port Static RAM				
Document Number: 38-06056				
Revision	ECN	Submission Date	Orig. of Change	Description of Change
**	110215	12/18/01	SZV	Change from Spec number: 38-00668 to 38-06056
*A	122306	12/27/02	RBI	Power up requirements added to Maximum Ratings Information
*B	344354	See ECN	PCX	Added Pb-Free Part Ordering Information
*C	2678221	03/25/2009	VKN / AESA	Added CY7C09379V-12AXCT part. Updated 51-85048 to *C.
*D	2896210	03/22/2010	RAME	Updated Ordering Information . Updated Package Diagrams .
*E	3111417	12/15/2010	ADMU	Updated Ordering Information . Added Ordering Code Definitions .
*F	3124048	12/30/2010	ADMU	No technical updates.
*G	3352110	08/23/2011	ADMU	Updated Features (Removed CY7C09379V information and also removed -6 speed bin information). Updated Pin Configurations (Removed CY7C09379V information). Updated Selection Guide (Removed CY7C09379V information and also removed -6 speed bin information). Updated Functional Description (Removed CY7C09379V information). Updated Electrical Characteristics (Removed CY7C09379V information and also removed -6 speed bin information). Updated AC Test Loads and Waveforms (Removed -6 speed bin information). Updated Switching Characteristics (Removed CY7C09379V information and also removed -6 speed bin information). Updated Ordering Information (Removed part CY7C09279V-7AC). Updated Package Diagrams . Added Acronyms and Units of Measure . Updated in new template.
*H	3402091	10/12/2011	ADMU	Updated Ordering Information (Removed pruned part CY7C09289V-9AI). Updated Package Diagrams .
*I	3680923	08/01/2012	ADMU / SMCH	Updated Pin Configurations (Updated Figure 2). Updated Switching Characteristics (Changed name of parameter from t_{CKZ} to t_{CKHZ} , changed name of parameter from t_{CKZ} to t_{CKLZ} in the next corresponding row). Updated Switching Waveforms (Updated Figure 15). Updated Address Counter Control Operation . Updated Ordering Information (Removed pruned part CY7C09289V-9AC). Updated Package Diagrams (spec 51-85048 (Changed revision from *E to *G)).

Sales, Solutions, and Legal Information

Worldwide Sales and Design Support

Cypress maintains a worldwide network of offices, solution centers, manufacturer's representatives, and distributors. To find the office closest to you, visit us at cypress.com/sales.

Products

Automotive	cypress.com/go/automotive
Clocks & Buffers	cypress.com/go/clocks
Interface	cypress.com/go/interface
Lighting & Power Control	cypress.com/go/powerpsoc
	cypress.com/go/plc
Memory	cypress.com/go/memory
Optical & Image Sensing	cypress.com/go/image
PSoC	cypress.com/go/psoc
Touch Sensing	cypress.com/go/touch
USB Controllers	cypress.com/go/USB
Wireless/RF	cypress.com/go/wireless

PSoC Solutions

psoc.cypress.com/solutions

[PSoC 1](#) | [PSoC 3](#) | [PSoC 5](#)

© Cypress Semiconductor Corporation, 2001-2012. The information contained herein is subject to change without notice. Cypress Semiconductor Corporation assumes no responsibility for the use of any circuitry other than circuitry embodied in a Cypress product. Nor does it convey or imply any license under patent or other rights. Cypress products are not warranted nor intended to be used for medical, life support, life saving, critical control or safety applications, unless pursuant to an express written agreement with Cypress. Furthermore, Cypress does not authorize its products for use as critical components in life-support systems where a malfunction or failure may reasonably be expected to result in significant injury to the user. The inclusion of Cypress products in life-support systems application implies that the manufacturer assumes all risk of such use and in doing so indemnifies Cypress against all charges.

Any Source Code (software and/or firmware) is owned by Cypress Semiconductor Corporation (Cypress) and is protected by and subject to worldwide patent protection (United States and foreign), United States copyright laws and international treaty provisions. Cypress hereby grants to licensee a personal, non-exclusive, non-transferable license to copy, use, modify, create derivative works of, and compile the Cypress Source Code and derivative works for the sole purpose of creating custom software and or firmware in support of licensee product to be used only in conjunction with a Cypress integrated circuit as specified in the applicable agreement. Any reproduction, modification, translation, compilation, or representation of this Source Code except as specified above is prohibited without the express written permission of Cypress.

Disclaimer: CYPRESS MAKES NO WARRANTY OF ANY KIND, EXPRESS OR IMPLIED, WITH REGARD TO THIS MATERIAL, INCLUDING, BUT NOT LIMITED TO, THE IMPLIED WARRANTIES OF MERCHANTABILITY AND FITNESS FOR A PARTICULAR PURPOSE. Cypress reserves the right to make changes without further notice to the materials described herein. Cypress does not assume any liability arising out of the application or use of any product or circuit described herein. Cypress does not authorize its products for use as critical components in life-support systems where a malfunction or failure may reasonably be expected to result in significant injury to the user. The inclusion of Cypress' product in a life-support systems application implies that the manufacturer assumes all risk of such use and in doing so indemnifies Cypress against all charges.

Use may be limited by and subject to the applicable Cypress software license agreement.