

Spread Spectrum Clock Generator

Features

- 25 MHz to 100 MHz operating frequency range
- Nine different spread select options
- Accepts clock and crystal inputs
- Low power dissipation:
 - 56 mW at Fin = 25 MHz
 - 89 mW at Fin = 65 MHz
 - 139 mW at Fin = 100 MHz
- Frequency spread disable function
- Center spread modulation
- Low cycle-to-cycle jitter
- 8-pin SOIC package
- Commercial and industrial temperature ranges

Applications

- Desktop, notebook, and tablet PCs
- VGA controllers
- LCD panels and monitors
- Printers and multifunction devices (MFP)

Benefits

- Peak electromagnetic interference (EMI) reduction by 8 to 16 dB
- Fast time to market
- Cost reduction

Logic Block

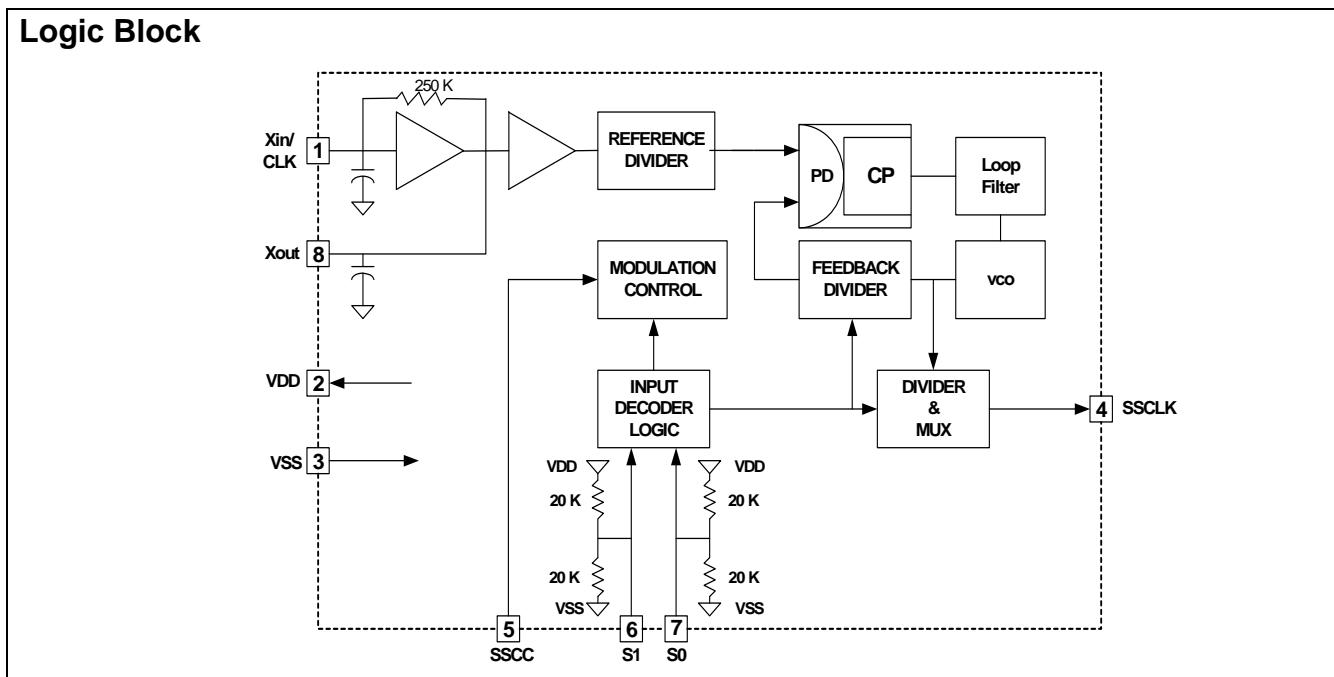

Contents

Pinouts	3	Ordering Code Definition	9
General Description	3	Package Drawing and Dimensions	10
Tri-Level Logic	4	Acronyms	11
SSCG Theory of Operation	4	Document Conventions	11
EMI	4	Units of Measure	11
SSCG	5	Document History Page	12
Modulation Rate	5	Sales, Solutions, and Legal Information	13
CY25560 Application Schematic	6	Worldwide Sales and Design Support	13
Absolute Maximum Ratings	7	Products	13
Absolute Maximum Conditions	8		
Ordering Information	9		

Pinouts

Figure 1. Pin Configuration – 8-Pin SOIC Package

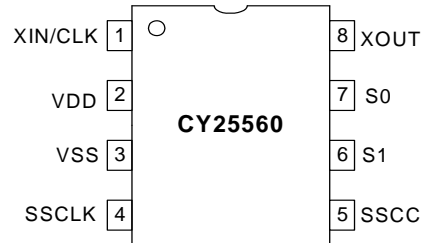

Table 1. Pin Description

Pin Number	Pin Name	Type	Pin Description
1	Xin/CLK	I	Clock or crystal connection input. See the Table 2 on page 4 for input frequency range selection.
2	VDD	P	Positive power supply.
3	GND	P	Power supply ground.
4	SSCLK	O	Modulated clock output, that is the same frequency as the input clock or the crystal frequency.
5	SSCC	I	Spread spectrum clock control (enable/disable) function. SSCG function is enabled when input is high and disabled when input is low. This pin is pulled high internally.
6	S1	I	Tri-level logic input control pin used to select input frequency range and spread percent. See the “ Tri-Level Logic ” on page 4 for programming details. Pin 6 has an internal resistor divider network to V_{DD} and V_{SS} . See the Logic Block Diagram on page 1 .
7	S0	I	Tri-level logic input control pin used to select input frequency range and spread percent. See the “ Tri-Level Logic ” on page 4 for programming details. Pin 7 has an internal resistor divider network to V_{DD} and V_{SS} . See the Logic Block Diagram on page 1 .
8	Xout	O	Oscillator output pin connected to crystal. Leave this pin unconnected if an external clock is used to drive xin/clk input (Pin 1).

General Description

The Cypress CY25560 is a spread spectrum clock generator (SSCG) IC used to reduce the EMI found in today’s high-speed digital electronic systems.

The CY25560 uses Cypress’s proprietary phase-locked loop (PLL) and spread spectrum clock (SSC) technology to synthesize and frequency modulate the input frequency of the reference clock. By frequency modulating the clock, the measured EMI at the fundamental and harmonic frequencies of clock (SSCLK) is greatly reduced.

This reduction in radiated energy can significantly reduce the cost of complying with regulatory requirements and time to market without degrading system performance.

The CY25560 is a very simple and versatile device to use. The frequency and spread% range is selected by programming S0 and S1 digital inputs. These inputs use three (3) logic states including High (H), Low (L), and Middle (M) logic levels to select one of the nine available spread% ranges. See the [Table 2 on page 4](#) for programming details.

CY25560 is optimized for SVGA (40 MHz) and XVGA (65 MHz) controller clocks and also suitable for applications where the frequency range is 25 MHz to 100 MHz.

A wide range of digitally selectable spread percentages is made possible by using three-level (High, Low, and Middle) logic at the S0 and S1 digital control inputs.

The output spread (frequency modulation) is symmetrically centered on the input frequency.

Spread spectrum clock control (SSCC) function enables or disables the frequency spread and is provided for easy comparison of system performance during EMI testing.

The CY25560 is available in an 8-pin SOIC package with 0 °C to 70 °C Commercial and –40 °C to 85 °C Industrial operating temperature ranges.

Figure 2. Three-Level Logic Examples

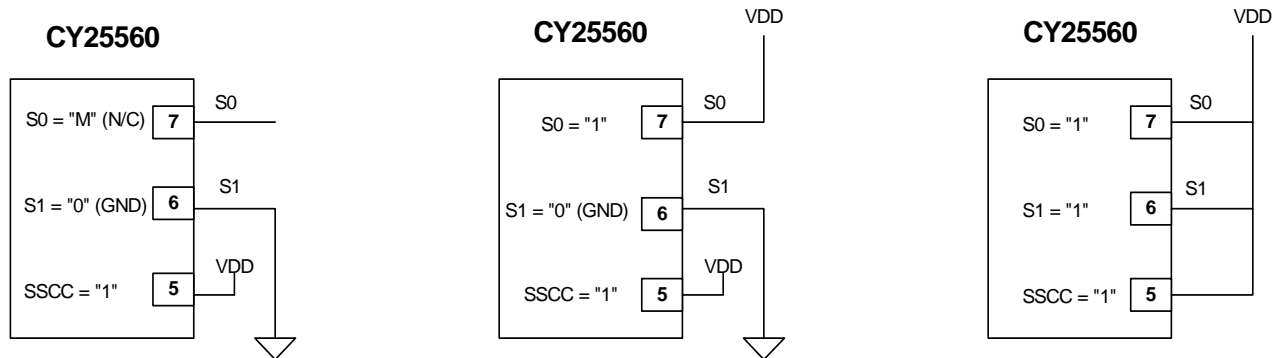

Table 2. Frequency and Spread% Selection

25 – 50 MHz (Low Range)

Input Frequency (MHz)	S1=M S0=M (%)	S1=M S0=0 (%)	S1=1 S0=0 (%)	S1=0 S0=0 (%)	S1=0 S0=M (%)
25 – 35	4.3	3.8	3.4	2.9	2.8
35 – 40	3.9	3.5	3.1	2.5	2.4
40 – 45	3.7	3.3	2.8	2.4	2.3
45 – 50	3.4	3.1	2.6	2.2	2.1

Select the Frequency and Center Spread % desired and then set S1, S0 as indicated.

50 – 100 MHz (High Range)

Input Frequency (MHz)	S1=1 S0=M (%)	S1=0 S0=1 (%)	S1=1 S0=1 (%)	S1=M S0=1 (%)
50 – 60	2.9	2.1	1.5	1.2
60 – 70	2.8	2.0	1.4	1.1
70 – 80	2.6	1.8	1.3	1.1
80 – 100	2.4	1.7	1.2	1.0

Select the Frequency and Center Spread % desired and then set S1, S0 as indicated.

Tri-Level Logic

With binary logic, four states can be programmed with two control lines, whereas three-level logic can program nine logic states using two control lines. Three-level logic in the CY25560 is implemented by defining a third logic state in addition to the standard logic '1' and '0'. Pins 6 and 7 of the CY25560 recognize a logic state by the voltage applied to their respective pin. These states are defined as '0' (Low), 'M' (Middle), and '1' (One). Each of these states have a defined voltage range that is interpreted by the CY25560 as a '0', 'M', or '1' logic state. See the Table 3 for voltage ranges for each logic state. The CY25560 has two equal value resistor dividers connected internally to Pins 6 and 7 that produce the default 'M' (Middle) state if these pins are left unconnected (NC). Pins 6 and/or 7 can be tied directly to ground or V_{DD} to program a logic '0' or '1' state, respectively.

SSCG Theory of Operation

The CY25560 is a PLL-type clock generator using a proprietary Cypress design. By precisely controlling the bandwidth of the output clock, the CY25560 becomes a low-EMI clock generator.

The theory and detailed operation of the CY25560 is discussed in the following sections.

EMI

All digital clocks generate unwanted energy in their harmonics. Conventional digital clocks are square waves with a duty cycle that is very close to 50 percent. Because of this 50/50 duty cycle, digital clocks generate most of their harmonic energy in the odd harmonics, i.e., third, fifth, seventh, and so on. It is possible to reduce the amount of energy contained in the fundamental and odd harmonics by increasing the bandwidth of the fundamental clock frequency. Conventional digital clocks have a very high Q factor, that means that all of the energy at that frequency is concentrated in a very narrow bandwidth, consequently, higher energy peaks. Regulatory agencies test electronic equipment by the amount of peak energy radiated from the equipment. By reducing the peak energy at the fundamental and harmonic frequencies, the equipment under test is able to satisfy agency requirements for EMI. Conventional methods of reducing EMI have been to use shielding, filtering, multilayer PCBs, and so on. The CY25560 uses the approach of reducing the peak energy in the clock by increasing the clock bandwidth, and lowering the Q factor.

SSCG

SSCG uses a patented technology of modulating the clock over a very narrow bandwidth and controlled rate of change, both peak and cycle-to-cycle. The CY25560 takes a narrow band digital reference clock in the range of 25 to 100 MHz and produces a clock that sweeps between a controlled start and stop frequency and precise rate of change. To understand what happens to a clock when SSCG is applied, consider a 65 MHz clock with a 50 percent duty cycle. From a 65 MHz clock we know the following:

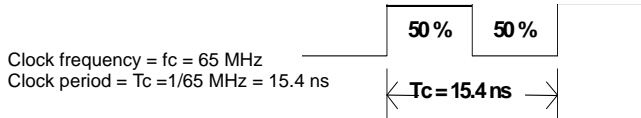

If this clock is applied to the Xin/CLK pin of CY25560, the output clock at Pin 4 (SSCLK) sweeps back and forth between two frequencies. These two frequencies, F1 and F2, are used to calculate to total amount of spread or bandwidth applied to the reference clock at Pin 1. As the clock is making the transition from F1 to F2, the amount of time and sweep waveform play a very important role in the amount of EMI reduction realized from an SSCG clock.

The modulation domain analyzer is used to visualize the sweep waveform and sweep period. Figure 3 shows the modulation profile of a 65 MHz SSCG clock. Notice that the actual sweep waveform is not a simple sine or sawtooth waveform. Figure 3 also shows a scan of the same SSCG clock using a spectrum analyzer. In this scan you can see a 6.48 dB reduction in the peak RF energy when using the SSCG clock.

Modulation Rate

SSCGs utilize frequency modulation (FM) to distribute energy over a specific band of frequencies. The maximum frequency of the clock (Fmax) and minimum frequency of the clock (Fmin) determine this band of frequencies. The time required to transition from Fmin to Fmax and back to Fmin is the period of the Modulation Rate, Tmod. Modulation Rates of SSCG clocks are generally referred to in terms of frequency or Fmod = 1/Tmod.

The input clock frequency, Fin, and the internal divider count, Cdiv, determine the Modulation Rate. In some SSCG clock generators, the selected range determines the internal divider count. In other SSCG clocks, the internal divider count is fixed over the operating range of the device. The CY25560 has a fixed divider count of 1166.

Figure 3. SSCG Clock, CY25560, Fin = 65 MHz

Device	Divider Count (Cdiv)
CY25560	1166 (All Ranges)

Example:

Device =	CY25560
Fin =	65 MHz
Range =	S1 = 1, S0 = 0

Then:

Modulation Rate = Fmod = 65 MHz/1166 = 55.7 kHz.

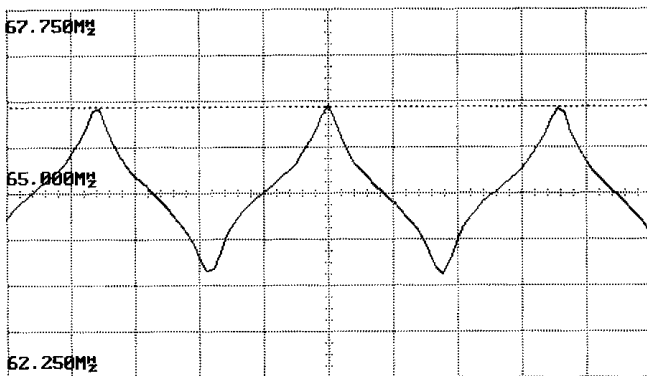

Modulation Profile

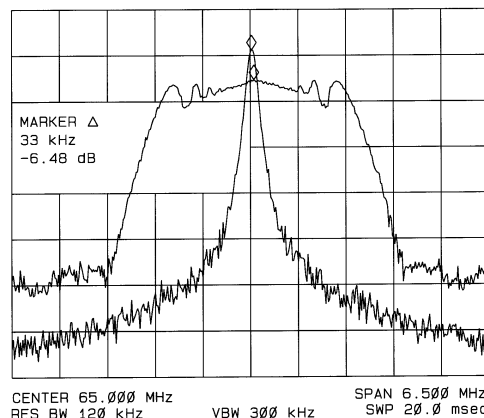

Spectrum Analyzer

CY25560 Application Schematic

The schematic in Figure 4 demonstrates how the CY25560 is configured in a typical application. This application is shown as using a 30 MHz fundamental crystal. In most applications, an external reference clock is used. Apply the external clock signal at Xin (Pin 1) and leave Xout (Pin 8) unconnected (see Table 1 for pin descriptions).

Contact Cypress if higher order crystal is to be used.

Figure 4. Application Schematic

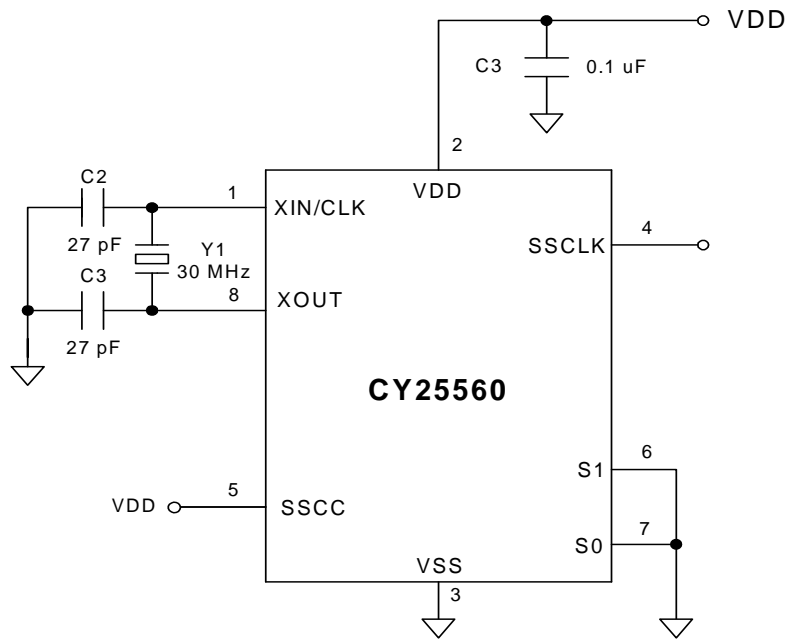

Absolute Maximum Ratings

Commercial Grade^[1, 2]

- Supply Voltage (V_{DD}):.....-0.5 V to +6.0 V
- DC Input Voltage:-0.5 V to $V_{DD}+0.5$ V
- Junction Temperature -40 °C to +140 °C
- Operating Temperature:..... 0 °C to 70 °C
- Storage Temperature -65 °C to +150 °C
- Static Discharge Voltage (ESD) 2,000 V-Min

Table 3. DC Electrical Characteristics

$V_{DD} = 3.3$ V \pm 10%, T = 0 °C to 70 °C and C_L (Pin 4) = 15 pF, Unless Otherwise Noted

Parameter	Description	Conditions	Min	Typ	Max	Unit
V_{DD}	Power supply range	$\pm 10\%$	2.97	3.3	3.63	V
V_{IH}	Input high voltage	S0 and S1 only	$0.85 V_{DD}$	V_{DD}	V_{DD}	V
V_{IM}	Input middle voltage	S0 and S1 only	$0.40 V_{DD}$	$0.50 V_{DD}$	$0.60 V_{DD}$	V
V_{IL}	Input low voltage	S0 and S1 only	0.0	0.0	$0.15 V_{DD}$	V
V_{OH}	Output high voltage	$I_{OH} = 6$ mA	2.4	–	–	V
V_{OL}	Output low voltage	$I_{OH} = 6$ mA	–	–	0.4	V
C_{in1}	Input capacitance	Xin/CLK (Pin 1)	3	4	5	pF
C_{in2}	Input capacitance	Xout (Pin 8)	6	8	10	pF
C_{in2}	Input capacitance	S0, S1, SSCC (Pins 7, 6, 5)	3	4	5	pF
I_{DD1}	Power supply current	FIN = 25 MHz, CL= 0	–	17	23	mA
I_{DD2}	Power supply current	FIN = 65 MHz, CL= 0	–	27	41	mA
I_{DD3}	Power supply current	FIN = 100 MHz, CL= 0	–	42	59	mA

Table 4. Electrical Timing Characteristics

$V_{DD} = 3.3$ V \pm 10%, T = 0 °C to 70 °C and C_L (Pin 4) = 15 pF, Unless Otherwise Noted

Parameter	Description	Conditions	Min	Typ	Max	Unit
I_{CLKFR}	Input clock frequency range	$V_{DD} = 3.30$ V	25	–	100	MHz
t_F	Clock rise time (Pin 4)	SSCLK at 0.4 – 2.4 V	1.0	1.8	2.8	ns
t_R	Clock fall time (Pin 4)	SSCLK at 0.4 – 2.4 V	1.0	1.8	2.8	ns
D_{TYin}	Input clock duty cycle	XIN/CLK (Pin 1)	25	50	75	%
D_{TYout}	Output clock duty cycle	SSCLK (Pin 4)	45	50	55	%
J_{CC1}	Cycle-to-cycle jitter	Fin = 25 MHz–50 MHz, SSCC = 1	–	150	300	ps
J_{CC2}	Cycle-to-cycle jitter	Fin = 50 MHz–100 MHz, SSCC = 1	–	130	200	ps

Notes

1. Operation at any Absolute Maximum Rating is not implied.
2. Single Power Supply: The voltage on any input or I/O pin cannot exceed the power pin during power-up.

Absolute Maximum Conditions

Industrial Grade^[3, 4]

- Supply Voltage (V_{DD}):.....-0.5 V to +6.0 V
- DC Input Voltage:-0.5 V to V_{DD}+0.5 V
- Junction Temperature -40 °C to +140 °C
- Operating Temperature:..... -40 °C to 85 °C
- Storage Temperature -65 °C to +150 °C
- Static Discharge Voltage (ESD) 2,000 V-Min

Table 5. DC Electrical Characteristics (Preliminary)

V_{DD} = 3.3 V ± 10%, T= -40 °C to 85 °C and C_L (Pin 4) = 15 pF, Unless Otherwise Noted

Parameter	Description	Conditions	Min	Typ	Max	Unit
V _{DD}	Power supply range	±10%	2.97	3.3	3.63	V
V _{IH}	Input high voltage	S0 and S1 only	0.85 V _{DD}	V _{DD}	V _{DD}	V
V _{IM}	Input middle voltage	S0 and S1 only	0.40 V _{DD}	0.50 V _{DD}	0.60 V _{DD}	V
V _{IL}	Input low voltage	S0 and S1 only	0.0	0.0	0.15 V _{DD}	V
V _{OH}	Output high voltage	I _{OH} = 6 mA	2.2	–	–	V
V _{OL}	Output low voltage	I _{OH} = 6 mA	–	–	0.4	V
C _{in1}	Input capacitance	Xin/CLK (Pin 1)	3	4	5	pF
C _{in2}	Input capacitance	Xout (Pin 8)	6	8	10	pF
C _{in2}	Input capacitance	S0, S1, SSCC (Pins 7, 6, 5)	3	4	5	pF
I _{DD1}	Power supply current	FIN = 25 MHz, CL= 0	–	17	24	mA
I _{DD2}	Power supply current	FIN = 65 MHz, CL= 0	–	27	41	mA
I _{DD3}	Power supply current	FIN = 100 MHz, CL= 0	–	42	61	mA

Table 6. Electrical Timing Characteristics (Preliminary)

V_{DD} = 3.3 V ± 10%, T= -40 °C to 85 °C and C_L (Pin 4) = 15 pF, Unless Otherwise Noted

Parameter	Description	Conditions	Min	Typ	Max	Unit
I _{CLKFR}	Input clock frequency range	V _{DD} = 3.30 V	25	–	100	MHz
t _F	Clock rise time (Pin 4)	SSCLK at 0.4 – 2.4 V	1.0	1.8	3.0	ns
t _R	Clock fall time (Pin 4)	SSCLK at 0.4 – 2.4 V	1.0	1.8	3.0	ns
D _{TYin}	Input clock duty cycle	XIN/CLK (Pin 1)	25	50	75	%
D _{TYout}	Output clock duty cycle	SSCLK (Pin 4)	45	50	55	%
J _{CC1}	Cycle-to-cycle jitter	Fin = 25 MHz–50 MHz, SSCC = 1	–	150	300	ps
J _{CC2}	Cycle-to-cycle jitter	Fin = 50 MHz–100 MHz, SSCC = 1	–	130	200	ps

Notes

- 3. Operation at any Absolute Maximum Rating is not implied.
- 4. Single Power Supply: The voltage on any input or I/O pin cannot exceed the power pin during power-up.

Ordering Information

Part Number	Package Type	Product Flow
Pb-free		
CY25560SXC	8-pin SOIC	Commercial, 0 °C to 70 °C
CY25560SXCT	8-pin SOIC – Tape and Reel	Commercial, 0 °C to 70 °C
CY25560SXI	8-pin SOIC	Industrial, –40 °C to 85 °C
CY25560SXIT	8-pin SOIC – Tape and Reel	Industrial, –40 °C to 85 °C

Ordering Code Definition

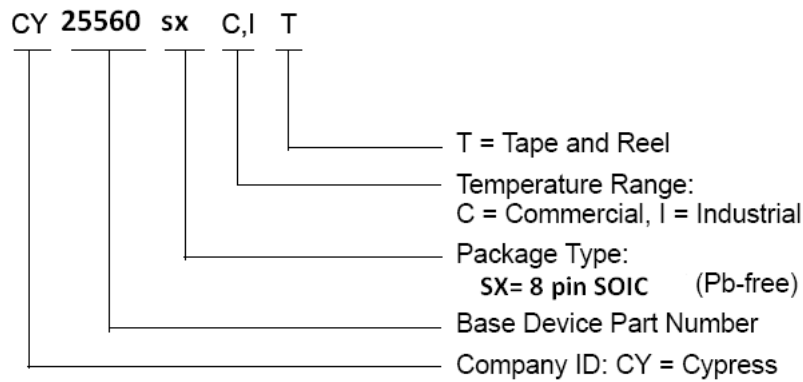

Package Drawing and Dimensions

Figure 5. 8-Pin (150-Mil) SOIC S8

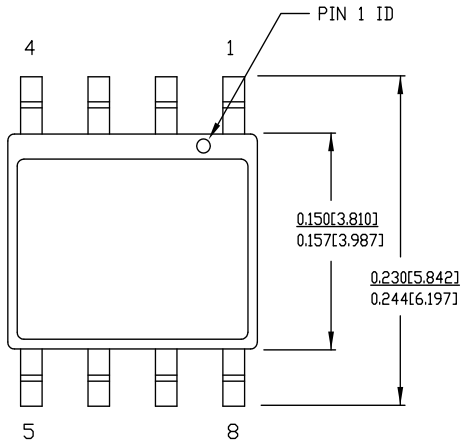

1. DIMENSIONS IN INCHES[MM] MIN. MAX.
2. PIN 1 ID IS OPTIONAL, ROUND ON SINGLE LEADFRAME RECTANGULAR ON MATRIX LEADFRAME
3. REFERENCE JEDEC MS-012
4. PACKAGE WEIGHT 0.07gms

PART #	
S08.15	STANDARD PKG.
SZ08.15	LEAD FREE PKG.

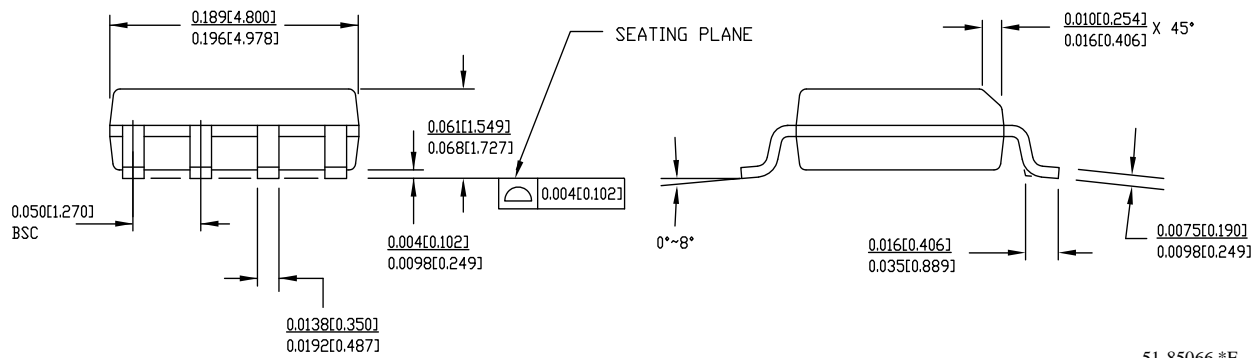

51-85066 *E

Acronyms

Acronym	Description
EMI	electromagnetic interference
ESD	electrostatic discharge
PLL	phase locked loop
SSC	spread spectrum clock
SSCG	spread spectrum clock generator
SVGA	super video graphics array
XVGA	extended video graphics array

Document Conventions

Units of Measure

Symbol	Unit of Measure
°C	degree Celcius
MHz	megahertz
mA	milliamperes
ns	nanoseconds
%	percent
pF	picofarads
ps	picoseconds

Document History Page

Document Title: CY25560 Spread Spectrum Clock Generator Document Number: 38-07425				
Revision	ECN	Orig. of Change	Submission Date	Description of Change
**	115261	OXC	06/12/02	New Datasheet.
*A	119441	RGL	10/17/02	Corrected the values in the Absolute Maximum Ratings to match the device.
*B	122704	RBI	12/30/02	Added power up requirements to maximum ratings information.
*C	125549	RGL	05/15/03	Added Industrial Temperature Range to the device. Removed V_{OL2} and V_{OH2} spec in the DC specs table Changed IDD Values from 11/17/25 typ and 14/22/34max to 17/27/42 typ and 23/41/59 max Changed T_F/T_R values from 1.3/1.3 typ and 1.6/1.6 max to 1.8/1.8 typ and 2.8/2.8 max in the Electrical Char. table. Changed $J_{CC1/2}$ values from 200/250 typ and 250/300 max to 150/130 typ to 300/200 max in the Electrical Char. table. Changed the low power dissipation from 36/56/82mW to 56/89/139mW respectively. Changed the low cycle-to-cycle jitter from 195/175/100ps-typ to 450/225/150 ps-max
*D	314293	RGL	See ECN	Added Pb-free devices.
*E	2762435	CXQ/HMT	09/11/09	Fixed the frequency in figure of SSCG section on page 3. Removed Pb devices from Ordering Information table.
*F	2819309	VED	12/01/09	Minor change - updated revision number and corrected the document number at the beginning of this table.
*G	3343531	PURU	08/12/2011	Added Ordering Code Definition , Acronyms , and Units of Measure . Updated Package Drawing and Dimensions .

Sales, Solutions, and Legal Information

Worldwide Sales and Design Support

Cypress maintains a worldwide network of offices, solution centers, manufacturer's representatives, and distributors. To find the office closest to you, visit us at cypress.com/sales.

Products

PSoC	psoc.cypress.com
Clocks & Buffers	clocks.cypress.com
Wireless	wireless.cypress.com
Memories	memory.cypress.com
Image Sensors	image.cypress.com

© Cypress Semiconductor Corporation, 2005-2011. The information contained herein is subject to change without notice. Cypress Semiconductor Corporation assumes no responsibility for the use of any circuitry other than circuitry embodied in a Cypress product. Nor does it convey or imply any license under patent or other rights. Cypress products are not warranted nor intended to be used for medical, life support, life saving, critical control or safety applications, unless pursuant to an express written agreement with Cypress. Furthermore, Cypress does not authorize its products for use as critical components in life-support systems where a malfunction or failure may reasonably be expected to result in significant injury to the user. The inclusion of Cypress products in life-support systems application implies that the manufacturer assumes all risk of such use and in doing so indemnifies Cypress against all charges.

Any Source Code (software and/or firmware) is owned by Cypress Semiconductor Corporation (Cypress) and is protected by and subject to worldwide patent protection (United States and foreign), United States copyright laws and international treaty provisions. Cypress hereby grants to licensee a personal, non-exclusive, non-transferable license to copy, use, modify, create derivative works of, and compile the Cypress Source Code and derivative works for the sole purpose of creating custom software and or firmware in support of licensee product to be used only in conjunction with a Cypress integrated circuit as specified in the applicable agreement. Any reproduction, modification, translation, compilation, or representation of this Source Code except as specified above is prohibited without the express written permission of Cypress.

Disclaimer: CYPRESS MAKES NO WARRANTY OF ANY KIND, EXPRESS OR IMPLIED, WITH REGARD TO THIS MATERIAL, INCLUDING, BUT NOT LIMITED TO, THE IMPLIED WARRANTIES OF MERCHANTABILITY AND FITNESS FOR A PARTICULAR PURPOSE. Cypress reserves the right to make changes without further notice to the materials described herein. Cypress does not assume any liability arising out of the application or use of any product or circuit described herein. Cypress does not authorize its products for use as critical components in life-support systems where a malfunction or failure may reasonably be expected to result in significant injury to the user. The inclusion of Cypress' product in a life-support systems application implies that the manufacturer assumes all risk of such use and in doing so indemnifies Cypress against all charges.

Use may be limited by and subject to the applicable Cypress software license agreement.