

FailSafe™ PacketClock Global Communications Clock Generator

Features

- Fully Integrated Phase-Locked Loop (PLL)
- FailSafe™ Output
- 8 kHz Reference Clock
- PLL Driven by a Crystal Oscillator that is Phase Aligned with External Reference
- Selectable Standard Communication Output Frequencies
- Low Jitter, High Accuracy Outputs
- 3.3 V Operation
- 16-pin TSSOP Package
- Commercial and Industrial Temperature Ranges

Functional Description

CY26049 is a FailSafe frequency synthesizer with a reference clock input and three clock outputs. The device provides an optimum solution for applications which require continuous operation in case of primary clock failure. The continuous, glitch-free operation is achieved by using a DCXO which serves as a primary clock source. The FailSafe control circuit synchronizes the DCXO with the reference as long as the reference is within the pull range of the crystal.

In the event of a reference clock failure the DCXO maintains the last frequency and phase information of the reference clock. The unique feature of the CY26049-36 is that the DCXO is, in fact, the primary clocking source. When the reference clock is restored, the DCXO automatically resynchronizes to the reference. The status of the reference clock input, as detected by the CY26049-36, is reported by the SAFE pin.

In the buffer mode (FS3:FS0 = 1110 or 1111), the CY26049-36 can be used as a jitter attenuator. In this mode, extensive jitter on the input clock is 'filtered', resulting in a low jitter output clock.

Logic Block Diagram

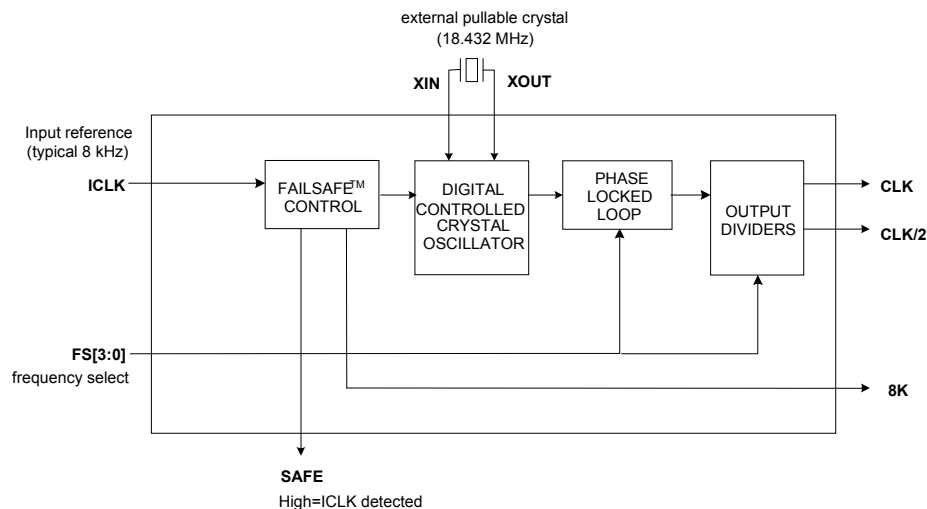

Contents

Pin Configuration	3	Ordering Information	8
Pin Definitions	3	Ordering Code Definitions	8
Frequency Select Tables	4	Package Diagram	9
Absolute Maximum Conditions	5	Acronyms	10
Recommended Pullable Crystal Specifications	5	Document Conventions	10
Recommended Operating Conditions	5	Units of Measure	10
DC Electrical Specifications	6	Document History Page	11
DC Electrical Specifications	6	Sales, Solutions, and Legal Information	12
AC Electrical Specifications	7	Worldwide Sales and Design Support	12
Voltage and Timing Definitions	7	Products	12
Test Circuit	8	PSoC Solutions	12

Pin Configuration

Figure 1. CY26049-36 16-pin TSSOP (Top View)

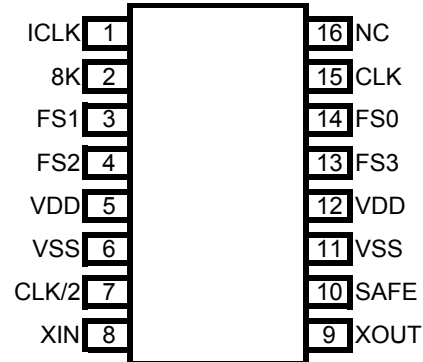

Pin Definitions

Pin Name	Pin Number	Pin Description
ICLK	1	Reference Input Clock ; 8 kHz or 10 to 60 MHz.
8K	2	Clock Output ; 8 kHz or high impedance in buffer mode.
FS1	3	Frequency Select 1 ; Determines CLK outputs according to Table 1 on page 4 .
FS2	4	Frequency Select 2 ; Determines CLK outputs according to Table 1 on page 4 .
VDD	5	Voltage Supply ; 3.3 V.
VSS	6	Ground
CLK/2	7	Clock Output ; Frequency according to Table 1 on page 4 .
XIN	8	Pullable Crystal Input ; 18.432 MHz.
XOUT	9	Pullable Crystal Output ; 18.432 MHz.
SAFE	10	High = reference ICLK within range, Low = reference ICLK out of range.
VSS	11	Ground
VDD	12	Voltage Supply ; 3.3 V.
FS3	13	Frequency Select 3 ; Determines CLK outputs according to Table 1 on page 4 .
FS0	14	Frequency Select 0 ; Determines CLK outputs according to Table 1 on page 4 .
CLK	15	Clock Output ; Frequency according to Table 1 on page 4 .
NC	16	No Connect

Frequency Select Tables

Table 1. CY26049-36 Frequency Select–Output Decoding Table–External Mode (MHz except as noted)

ICLK	FS3	FS2	FS1	FS0	CLK/2	CLK	8K	Crystal
8 kHz	0	0	0	0	1.544	3.088	8 kHz	18.432
8 kHz	0	0	0	1	2.048	4.096	8 kHz	18.432
8 kHz	0	0	1	0	22.368	44.736	8 kHz	18.432
8 kHz	0	0	1	1	17.184	34.368	8 kHz	18.432
8 kHz	0	1	0	0	77.76	155.52	8 kHz	18.432
8 kHz	0	1	0	1	16.384	32.768	8 kHz	18.432
8 kHz	0	1	1	0	14.352	28.704	8 kHz	18.432
8 kHz	0	1	1	1	High Z ^[1]	High Z ^[1]	High Z ^[1]	18.432
8 kHz	1	0	0	0	18.528	37.056	8 kHz	18.432
8 kHz	1	0	0	1	12.352	24.704	8 kHz	18.432
8 kHz	1	0	1	0	7.68	15.36	8 kHz	18.432
8 kHz	1	0	1	1	High Z ^[1]	High Z ^[1]	High Z ^[1]	18.432
8 kHz	1	1	0	0	12.288	24.576	8 kHz	18.432
8 kHz	1	1	0	1	16.384	32.768	8 kHz	18.432

Table 2. CY26049-36 Frequency Select–Output Decoding Table–Buffer Mode

ICLK	FS3	FS2	FS1	FS0	CLK/2	CLK	8K	Crystal
20 to 60 MHz	1	1	1	0	ICLK/2	ICLK	High Z ^[1]	ICLK/2
10 to 30 MHz	1	1	1	1	2 × ICLK	4 × ICLK	High Z ^[1]	ICLK

Note

1. High Z = high impedance.

Absolute Maximum Conditions

Exceeding maximum ratings may shorten the useful life of the device. User guidelines are not tested.

Supply Voltage (V_{DD}) -0.5 to +7.0 V
 DC Input Voltage -0.5 V to $V_{DD} + 0.5$ V

Storage Temperature
 (Non-Condensing) -55 °C to +125 °C
 Junction Temperature -40 °C to +125 °C
 Data Retention at $T_J = 125$ °C > 10 years
 Package Power Dissipation 350 mW
 ESD (Human Body Model) MIL-STD-883 2000 V

Recommended Pullable Crystal Specifications

Parameter ^[2]	Description	Comments	Min	Typ	Max	Units
F_{NOM}	Nominal crystal frequency	Parallel resonance, fundamental mode, AT cut	-	18.432	-	MHz
C_{LNOM}	Nominal load capacitance		-	14	-	pF
R_1	Equivalent series resistance (ESR)	Fundamental mode	-	-	25	Ω
R_3/R_1	Ratio of third overtone mode ESR to fundamental mode ESR	Ratio used because typical R_1 values are much less than the maximum spec	3	-	-	
DL	Crystal drive level	No external series resistor assumed	-	0.5	2	mW
F_{3SEPHI}	Third overtone separation from $3 \times F_{NOM}$	High side	400	-	-	ppm
F_{3SEPLO}	Third overtone separation from $3 \times F_{NOM}$	Low side	-	-	-200	ppm
C_0	Crystal shunt capacitance		-	-	7	pF
C_0/C_1	Ratio of shunt to motional capacitance		180	-	250	
C_1	Crystal motional capacitance		14.4	18	21.6	fF

Recommended Operating Conditions

Parameter	Description	Min	Typ	Max	Unit
V_{DD}	Operating Voltage	3.15	3.3	3.45	V
T_{AC}	Ambient Temperature (Commercial Temperature)	0	-	70	°C
T_{AI}	Ambient Temperature (Industrial Temperature)	-40	-	85	°C
C_{LOAD}	Max Output Load Capacitance	-	-	15	pF
t_{PU}	Power up time for all V_{DDs} to reach minimum specified voltage (power ramps must be monotonic)	0.05	-	500	ms
$t_{ER(I)}$	8 kHz Input Edge Rate, 20% to 80% of $V_{DD} = 3.3$ V	0.07	-	-	V/ns

Note
 2. Ecliptek crystals ECX-5761-18.432 M and ECX-5762-18.432 M meet these specifications.

DC Electrical Specifications

Commercial Temperature: 0 °C to 70 °C

Parameter	Description	Test Conditions	Min	Typ	Max	Unit
I_{OH}	Output High Current	$V_{OH} = V_{DD} - 0.5\text{ V}$, $V_{DD} = 3.3\text{ V}$ (source)	12	24	–	mA
I_{OL}	Output Low Current	$V_{OL} = 0.5\text{ V}$, $V_{DD} = 3.3\text{ V}$ (sink)	12	24	–	mA
V_{IH}	Input High Voltage	CMOS Levels	0.7	–	–	V_{DD}
V_{IL}	Input High Voltage	CMOS Levels	–	–	0.3	V_{DD}
I_{IH}	Input High Current	$V_{IH} = V_{DD}$	–	5	10	μA
I_{IL}	Input Low Current	$V_{IL} = 0\text{ V}$	–	5	10	μA
C_{IN}	Input Capacitance		–	–	7	pF
I_{OZ}	Output Leakage Current	High Z ^[3] output	–	± 5	–	μA
I_{DD}	Supply Current	$C_{LOAD} = 15\text{ pF}$, $V_{DD} = 3.45\text{ V}$, FS [3:0] = 0100	–	–	45	mA
		$C_{LOAD} = 15\text{ pF}$, $V_{DD} = 3.45\text{ V}$, FS [3:0] = 1101	–	–	30	mA

DC Electrical Specifications

Industrial Temperature: –40 °C to 85 °C

Parameter	Description	Test Conditions	Min	Typ	Max	Unit
I_{OH}	Output High Current	$V_{OH} = V_{DD} - 0.5\text{ V}$, $V_{DD} = 3.3\text{ V}$ (source)	10	20	–	mA
I_{OL}	Output Low Current	$V_{OL} = 0.5\text{ V}$, $V_{DD} = 3.3\text{ V}$ (sink)	10	20	–	mA
V_{IH}	Input High Voltage	CMOS Levels	0.7	–	–	V_{DD}
V_{IL}	Input High Voltage	CMOS Levels	–	–	0.3	V_{DD}
I_{IH}	Input High Current	$V_{IH} = V_{DD}$	–	5	10	μA
I_{IL}	Input Low Current	$V_{IL} = 0\text{ V}$	–	5	10	μA
C_{IN}	Input Capacitance		–	–	7	pF
I_{OZ}	Output Leakage Current	High Z ^[3] output	–	± 5	–	μA
I_{DD}	Supply Current	$C_{LOAD} = 15\text{ pF}$, $V_{DD} = 3.45\text{ V}$, FS [3:0] = 0100	–	–	50	mA
		$C_{LOAD} = 15\text{ pF}$, $V_{DD} = 3.45\text{ V}$, FS [3:0] = 1101	–	–	35	mA

Note

3. High Z = high impedance.

AC Electrical Specifications

Commercial Temperature: 0 °C to 70 °C and Industrial Temperature: -40 °C to 85 °C

Parameter	Description	Test Conditions	Min	Typ	Max	Unit
f _{ICLK-E}	Frequency, Input Clock	Input Clock Frequency, External Mode	-	8.00	-	kHz
f _{ICLK-B}	Frequency, Input Clock	Input Clock Frequency, Buffer Mode	10	-	60	MHz
LR	FailSafe Lock Range ^[4]	Range of reference ICLK for Safe = High	-250	-	+250	ppm
t _{DC} = t ₂ /t ₁	Output Duty Cycle	Duty Cycle defined in Figure 2, measured at 50% of V _{DD}	45	50	55	%
t _{PJIT1}	Clock Jitter; output > 5 MHz	Period Jitter, Peak to Peak, 10,000 periods	-	-	250	ps
		RMS Period Jitter, RMS	-	-	50	ps
t _{PJIT2}	Clock Jitter; output < 5 MHz	Period Jitter, Peak to Peak, 10,000 periods	-	-	500	ps
		RMS Period Jitter, RMS	-	-	100	ps
t _{P_LOCK}	PLL Lock Time ^[5]	Time for PLL to lock within ±150 ppm of target frequency	-	-	3	ms
t _{FS_LOCK}	Failsafe Lock Time ^[5]	Time for PLL to lock to ICKL (outputs phase aligned with ICKL and Safe = High)	-	-	7	s
f _{ERROR}	Frequency Synthesis Error	Actual mean frequency error versus target	-	0	-	ppm
ER	Rising Edge Rate	Output Clock Edge Rate, Measured from 20% to 80% of V _{DD} , C _{LOAD} = 15 pF. See Figure 3.	0.8	1.4	2	V/ns
EF	Falling Edge Rate	Output Clock Edge Rate, Measured from 20% to 80% of V _{DD} , C _{LOAD} = 15 pF. See Figure 3.	0.8	1.4	2	V/ns

Voltage and Timing Definitions

Figure 2. Duty Cycle Definition; DC = t₂/t₁

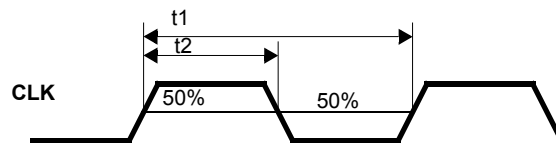
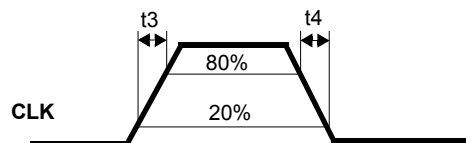

Figure 3. Rise and Fall Time Definitions: ER = 0.6 × VDD / t₃, EF = 0.6 × VDD / t₄



Notes

4. Dependent on crystals chosen and crystal specs.
5. Lock times are measured beginning when VDD has reached its minimum specified value and ICLK is stable.

Test Circuit

Figure 4. Test Circuit

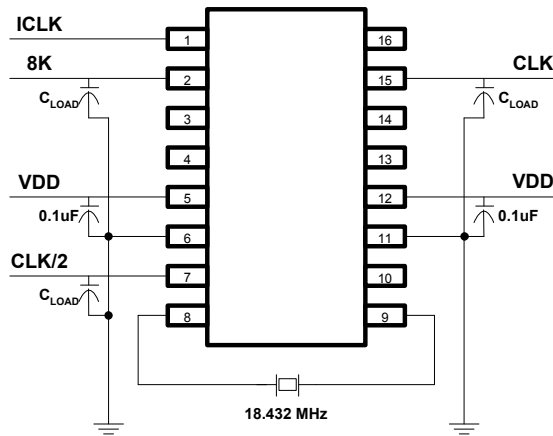

Ordering Information

Ordering Code	Package Type	Operating Temperature Range
Pb-free		
CY26049ZXC-36	16-pin TSSOP	Commercial, 0 °C to 70 °C
CY26049ZXC-36T	16-pin TSSOP–Tape and Reel	Commercial, 0 °C to 70 °C
CY26049ZXI-36	16-pin TSSOP	Industrial, –40 °C to 85 °C
CY26049ZXI-36T	16-pin TSSOP–Tape and Reel	Industrial, –40 °C to 85 °C

Ordering Code Definitions

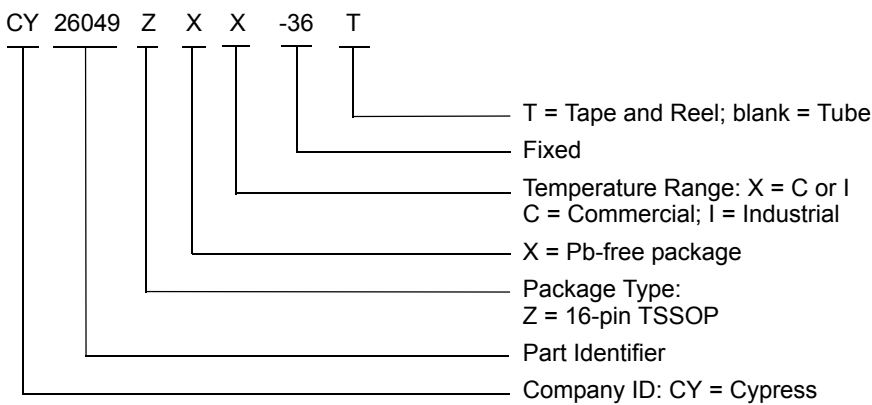

Package Diagram

Figure 5. 16-pin TSSOP 4.40 mm Body Z16.173/ZZ16.173 Package Outline

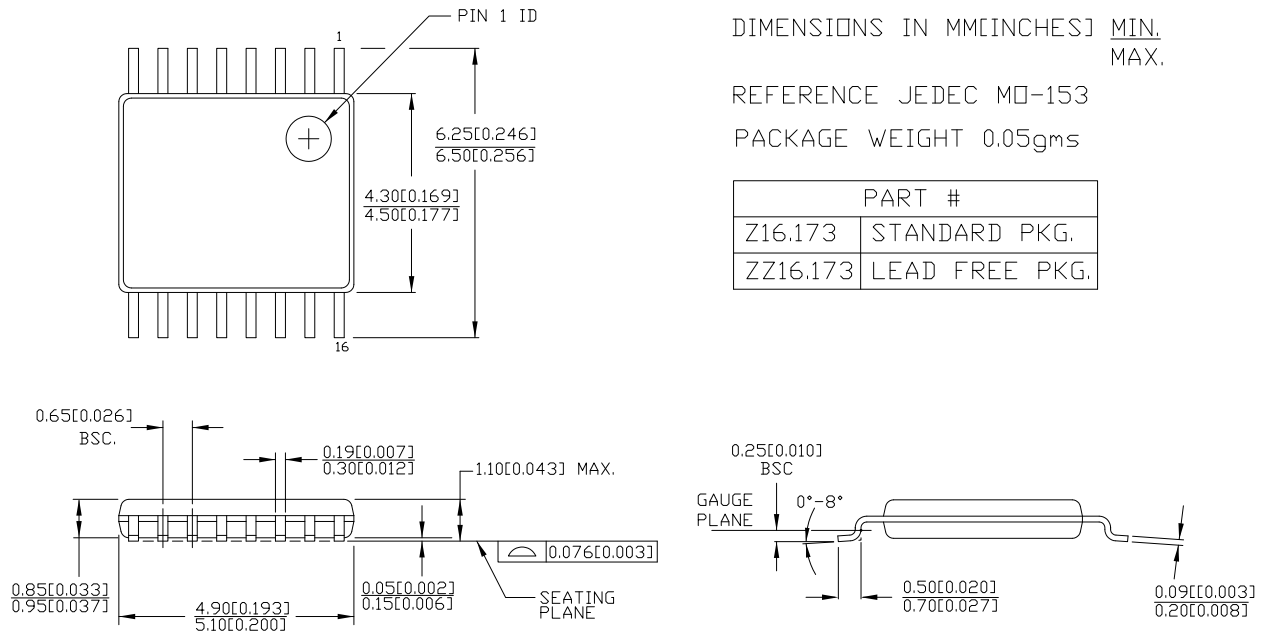

51-85091 °C

Acronyms

Acronym	Description
CMOS	complementary metal oxide semiconductor
DCXO	digital controlled crystal oscillator
ESD	electrostatic discharge
ESR	equivalent series resistance
JEDEC	joint electron devices engineering council
PLL	phase locked loop
TSSOP	thin shrunk small outline package

Document Conventions

Units of Measure

Symbol	Unit of Measure
°C	degree Celsius
fF	femtofarad
kHz	kilohertz
MHz	megahertz
μA	microampere
mA	milliampere
mm	millimeter
ms	millisecond
mW	milliwatt
ns	nanosecond
Ω	ohm
%	percent
pF	picofarad
ppm	parts per million
ps	picosecond
s	second
V	volt

Document History Page

Document Title: CY26049-36, FailSafe™ PacketClock Global Communications Clock Generator				
Document Number: 38-07415				
Rev.	ECN No.	Submission Date	Orig. of Change	Description of Change
**	114749	08/08/02	CKN	New Data Sheet
*A	120067	01/06/03	CKN	Changed “FailSafe is a trademark of Silicon Graphics, Inc.” to read “FailSafe is a trademark of Cypress Semiconductor”
*B	128000	07/15/03	IJA	Changed Benefits to read “When reference is in range, SAFE pin is driven high” Changed first sentence to “CY26049 is a FailSafe frequency synthesizer with a reference clock input and three clock outputs” Changed title from “Failsafe™ PacketClock™ Global Communications Clocks” to “FailSafe™ PacketClock™ Global Communications Clock Generator” Changed definitions in Pin Description Table Replaced format for Absolute Maximum Conditions Replaced Recommended Pullable Crystal Specifications table Added t_{pu} to Recommended Operating Conditions Added I_{IH} and I_{IL} to DC Electrical Specifications Replaced AC Electrical Specifications from Cy26049-16 data sheet Changed Voltage and Timing Definitions to match CY2410 data sheet Moved Package Diagram to end of data sheet
*C	244412	See ECN	RGL	Spec. ($t_{ER(I)}$) Input Edge Rate in the Recommended Operating Conditions Table Added Lead Free Devices
*D	2865396	01/25/2010	TSAI / KVM	Updated template Post to external web Added 8 kHz ref clock to p. 1 Features Moved Functional Description to p. 1, replacing Benefits section Removed Selector Guide table Added units (MHz) to ICLK column of Table 2 Standardized parameter name capitalization in AC Electrical table Changed timing parameter name t_6 to t_{P_LOCK} Added footnote for t_{P_LOCK} and t_{FS_LOCK} Remove part numbers CY26049ZC-36, CY26049ZC-36T, CY26049ZI-36 and CY26049ZI-36T
*E	2925613	04/30/10	KVM	Posting to external web.
*F	3377436	09/20/2011	PURU	Added Ordering Code Definitions . Updated Package Diagram . Added Acronyms and Units of Measure . Updated in new template.

Sales, Solutions, and Legal Information

Worldwide Sales and Design Support

Cypress maintains a worldwide network of offices, solution centers, manufacturer's representatives, and distributors. To find the office closest to you, visit us at [Cypress Locations](#).

Products

Automotive	cypress.com/go/automotive
Clocks & Buffers	cypress.com/go/clocks
Interface	cypress.com/go/interface
Lighting & Power Control	cypress.com/go/powerpsoc cypress.com/go/plc
Memory	cypress.com/go/memory
Optical & Image Sensing	cypress.com/go/image
PSoC	cypress.com/go/psoc
Touch Sensing	cypress.com/go/touch
USB Controllers	cypress.com/go/USB
Wireless/RF	cypress.com/go/wireless

PSoC Solutions

psoc.cypress.com/solutions
PSoC 1 | PSoC 3 | PSoC 5

© Cypress Semiconductor Corporation, 2002-2011. The information contained herein is subject to change without notice. Cypress Semiconductor Corporation assumes no responsibility for the use of any circuitry other than circuitry embodied in a Cypress product. Nor does it convey or imply any license under patent or other rights. Cypress products are not warranted nor intended to be used for medical, life support, life saving, critical control or safety applications, unless pursuant to an express written agreement with Cypress. Furthermore, Cypress does not authorize its products for use as critical components in life-support systems where a malfunction or failure may reasonably be expected to result in significant injury to the user. The inclusion of Cypress products in life-support systems application implies that the manufacturer assumes all risk of such use and in doing so indemnifies Cypress against all charges.

Any Source Code (software and/or firmware) is owned by Cypress Semiconductor Corporation (Cypress) and is protected by and subject to worldwide patent protection (United States and foreign), United States copyright laws and international treaty provisions. Cypress hereby grants to licensee a personal, non-exclusive, non-transferable license to copy, use, modify, create derivative works of, and compile the Cypress Source Code and derivative works for the sole purpose of creating custom software and or firmware in support of licensee product to be used only in conjunction with a Cypress integrated circuit as specified in the applicable agreement. Any reproduction, modification, translation, compilation, or representation of this Source Code except as specified above is prohibited without the express written permission of Cypress.

Disclaimer: CYPRESS MAKES NO WARRANTY OF ANY KIND, EXPRESS OR IMPLIED, WITH REGARD TO THIS MATERIAL, INCLUDING, BUT NOT LIMITED TO, THE IMPLIED WARRANTIES OF MERCHANTABILITY AND FITNESS FOR A PARTICULAR PURPOSE. Cypress reserves the right to make changes without further notice to the materials described herein. Cypress does not assume any liability arising out of the application or use of any product or circuit described herein. Cypress does not authorize its products for use as critical components in life-support systems where a malfunction or failure may reasonably be expected to result in significant injury to the user. The inclusion of Cypress' product in a life-support systems application implies that the manufacturer assumes all risk of such use and in doing so indemnifies Cypress against all charges.

Use may be limited by and subject to the applicable Cypress software license agreement.