

512 K (32 K x 16) Static RAM

Features

- Pin-and function-compatible with CY7C1020CV33
- High speed
 - $t_{AA} = 10 \text{ ns}$
- Low active power
 - $I_{CC} = 60 \text{ mA @ } 10 \text{ ns}$
- Low CMOS standby power
 - $I_{SB2} = 3 \text{ mA}$
- 2.0 V Data retention
- Automatic power-down when deselected
- CMOS for optimum speed/power
- Independent control of upper and lower bits
- Available in Pb-free 44-pin 400-Mil wide Molded SOJ and 44-pin TSOP II packages

Functional Description

The CY7C1020DV33 is a high-performance CMOS static RAM organized as 32,768 words by 16 bits. This device has

an automatic power-down feature that significantly reduces power consumption when deselected.

Writing to the device is accomplished by taking chip enable (CE) and write enable (WE) inputs LOW. If byte low enable (BLE) is LOW, then data from I/O pins (I/O₀ through I/O₇), is written into the location specified on the address pins (A₀ through A₁₄). If byte high enable (BHE) is LOW, then data from I/O pins (I/O₈ through I/O₁₅) is written into the location specified on the address pins (A₀ through A₁₄).

Reading from the device is accomplished by taking chip enable (CE) and output enable (OE) LOW while forcing the write enable (WE) HIGH. If byte low enable (BLE) is LOW, then data from the memory location specified by the address pins will appear on I/O₀ to I/O₇. If byte high enable (BHE) is LOW, then data from memory will appear on I/O₈ to I/O₁₅. See the truth table at the back of this data sheet for a complete description of read and write modes.

The input/output pins (I/O₀ through I/O₁₅) are placed in a high-impedance state when the device is deselected (CE HIGH), the outputs are disabled (OE HIGH), the BHE and BLE are disabled (BHE, BLE HIGH), or during a write operation (CE LOW, and WE LOW).

The CY7C1020DV33 is available in Pb-free 44-pin 400-Mil wide Molded SOJ and 44-pin TSOP II packages.

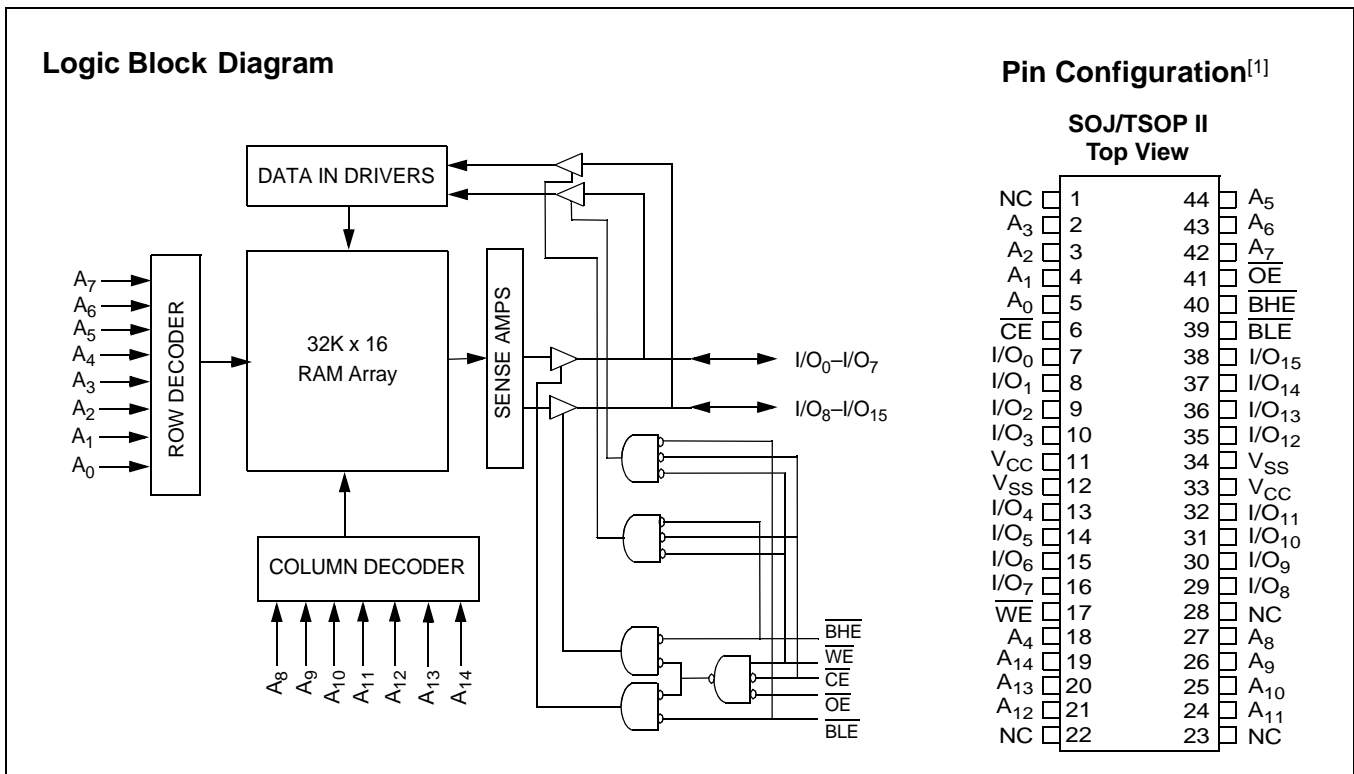

Notes

1. NC pins are not connected on the die.

Selection Guide

	-10 (Industrial)	Unit
Maximum access time	10	ns
Maximum operating current	60	mA
Maximum CMOS standby current	3	mA

Maximum Ratings

(Above which the useful life may be impaired. For user guidelines, not tested.)

Storage temperature -65 °C to +150 °C
 Ambient temperature with power applied -55 °C to +125 °C
 Supply voltage on V_{CC} to Relative GND^[2] ... -0.5 V to +4.6 V
 DC voltage applied to outputs in High-Z State^[2] -0.5 V to V_{CC} + 0.5 V

DC input voltage^[2] -0.5 V to V_{CC} + 0.5 V
 Current into outputs (LOW) 20 mA
 Static discharge voltage > 2001 V (per MIL-STD-883, Method 3015)
 Latch-up current > 200 mA

Operating Range

Range	Ambient Temperature	V_{CC}	Speed
Industrial	-40 °C to +85 °C	3.3 V ± 0.3 V	10 ns

Electrical Characteristics Over the Operating Range

Parameter	Description	Test Conditions	-10 (Industrial)		Unit
			Min.	Max.	
V _{OH}	Output HIGH voltage	V _{CC} = Min., I _{OH} = -4.0 mA	2.4		V
V _{OL}	Output LOW voltage	V _{CC} = Min., I _{OL} = 8.0 mA		0.4	V
V _{IH}	Input HIGH voltage		2.0	V _{CC} + 0.3	V
V _{IL}	Input LOW voltage ^[2]		-0.3	0.8	V
I _{IX}	Input Load current	GND ≤ V _I ≤ V _{CC}	-1	+1	μA
I _{OZ}	Output leakage current	GND ≤ V _I ≤ V _{CC} , Output Disabled	-1	+1	μA
I _{CC}	V _{CC} operating supply current	V _{CC} = Max., I _{OUT} = 0 mA, f = f _{MAX} = 1/t _{RC}	100 MHz	60	mA
			83 MHz	55	mA
			66 MHz	45	mA
			40 MHz	30	mA
I _{SB1}	Automatic CE Power-down Current—TTL Inputs	Max. V _{CC} , $\overline{CE} \geq V_{IH}$ V _{IN} ≥ V _{IH} or V _{IN} ≤ V _{IL} , f = f _{MAX}		10	mA
I _{SB2}	Automatic CE Power-down Current—CMOS Inputs	Max. V _{CC} , $\overline{CE} \geq V_{CC} - 0.3 V$, V _{IN} ≥ V _{CC} - 0.3 V, or V _{IN} ≤ 0.3 V, f = 0		3	mA

Notes

2. V_{IL}(min.) = -2.0 V and V_{IH}(max) = V_{CC} + 1 V for pulse durations of less than 5 ns.

Capacitance^[3]

Parameter	Description	Test Conditions	Max.	Unit
C _{IN}	Input capacitance	T _A = 25°C, f = 1 MHz, V _{CC} = 3.3 V	8	pF
C _{OUT}	Output capacitance		8	pF

Thermal Resistance^[3]

Parameter	Description	Test Conditions	SOJ	TSOP II	Unit
Θ _{JA}	Thermal resistance (Junction to Ambient)	Still air, soldered on a 3 × 4.5 inch, four-layer printed circuit board	59.52	53.91	°C/W
Θ _{JC}	Thermal resistance (Junction to Case)		36.75	21.24	°C/W

AC Test Loads and Waveforms^[4]

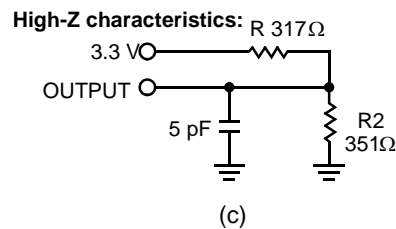
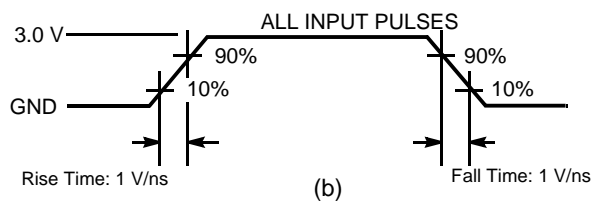
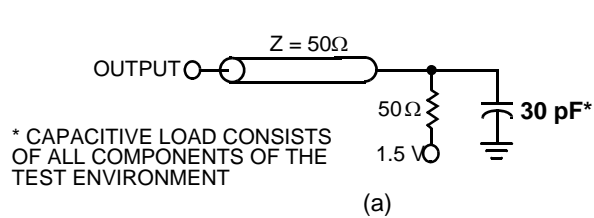

Notes

- Tested initially and after any design or process changes that may affect these parameters.
- AC characteristics (except High-Z) are tested using the load conditions shown in Figure (a). High-Z characteristics are tested for all speeds using the test load shown in Figure (c).

Switching Characteristics Over the Operating Range ^[5]

Parameter	Description	-10 (Industrial)		Unit
		Min.	Max.	
Read Cycle				
$t_{power}^{[6]}$	V_{CC} (typical) to the first access	100		μ S
t_{RC}	Read cycle time	10		ns
t_{AA}	Address to data valid		10	ns
t_{OHA}	Data Hold from Address Change	3		ns
t_{ACE}	\overline{CE} LOW to data valid		10	ns
t_{DOE}	\overline{OE} LOW to data valid		5	ns
t_{LZOE}	\overline{OE} LOW to Low-Z ^[7]	0		ns
t_{HZOE}	\overline{OE} HIGH to High-Z ^[7, 8]		5	ns
t_{LZCE}	\overline{CE} LOW to Low-Z ^[7]	3		ns
t_{HZCE}	\overline{CE} HIGH to High-Z ^[7, 8]		5	ns
$t_{PU}^{[9]}$	\overline{CE} LOW to Power-up	0		ns
$t_{PD}^{[9]}$	\overline{CE} HIGH to Power-down		10	ns
t_{DBE}	Byte enable to data valid		5	ns
t_{LZBE}	Byte enable to low-Z	0		ns
t_{HZBE}	Byte disable to high-Z		5	ns
Write Cycle^[10]				
t_{WC}	Write cycle time	10		ns
t_{SCE}	\overline{CE} LOW to write end	8		ns
t_{AW}	Address set-up to write end	8		ns
t_{HA}	Address hold from write end	0		ns
t_{SA}	Address set-up to write start	0		ns
t_{PWE}	\overline{WE} pulse width	7		ns
t_{SD}	Data set-up to write end	5		ns
t_{HD}	Data hold from write end	0		ns
t_{LZWE}	\overline{WE} HIGH to Low-Z ^[7]	3		ns
t_{HZWE}	\overline{WE} LOW to High-Z ^[7, 8]		5	ns
t_{BW}	Byte enable to end of write	7		ns

Notes

5. Test conditions assume signal transition time of 3 ns or less, timing reference levels of 1.5 V, input pulse levels of 0 to 3.0 V.
6. t_{POWER} gives the minimum amount of time that the power supply should be at typical V_{CC} values until the first memory access can be performed
7. t_{HZOE} , t_{HZBE} , t_{HZCE} , and t_{HZWE} are specified with a load capacitance of 5 pF as in (c) of AC Test Loads. Transition is measured when the outputs enter a high impedance state.
8. At any given temperature and voltage condition, t_{HZCE} is less than t_{LZCE} , t_{HZOE} is less than t_{LZOE} , and t_{HZWE} is less than t_{LZWE} for any given device.
9. This parameter is guaranteed by design and is not tested.
10. The internal Write time of the memory is defined by the overlap of \overline{CE} LOW, \overline{WE} LOW and $\overline{BHE}/\overline{BLE}$ LOW. \overline{CE} , \overline{WE} and $\overline{BHE}/\overline{BLE}$ must be LOW to initiate a Write and the transition of these signals can terminate the Write. The input data set-up and hold timing should be referenced to the leading edge of the signal that terminates the Write.

Data Retention Characteristics (Over the Operating Range)

Parameter	Description	Conditions	Min.	Max.	Unit
V_{DR}	V_{CC}		2.0		V
I_{CCDR}	Data retention current	$V_{CC} = V_{DR} = 2.0\text{ V}$, $\overline{CE} \geq V_{CC} - 0.3\text{ V}$, $V_{IN} \geq V_{CC} - 0.3\text{ V}$ or $V_{IN} \leq 0.3\text{ V}$		3	mA
$t_{CDR}^{[3]}$	Chip deselect to data retention time		0		ns
$t_R^{[11]}$	Operation recovery time		t_{RC}		ns

Data Retention Waveform

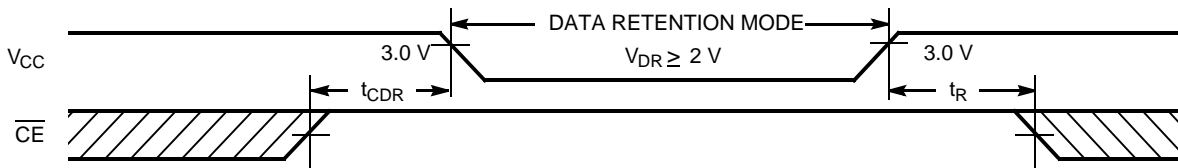

Switching Waveforms

Read Cycle No. 1 (Address Transition Controlled)^[12, 13]

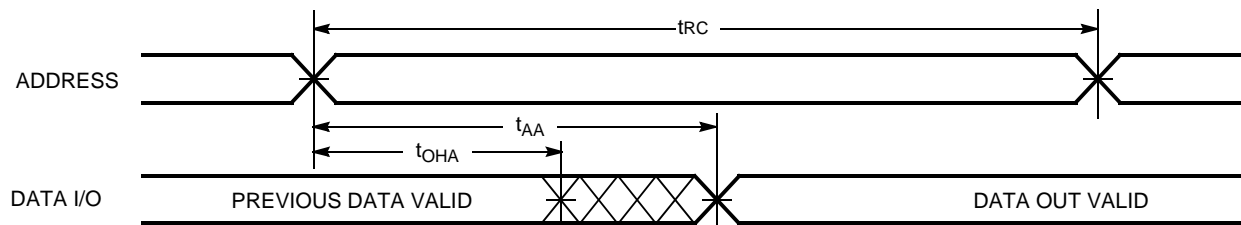

Read Cycle No. 2 (OE Controlled)^[13, 14]

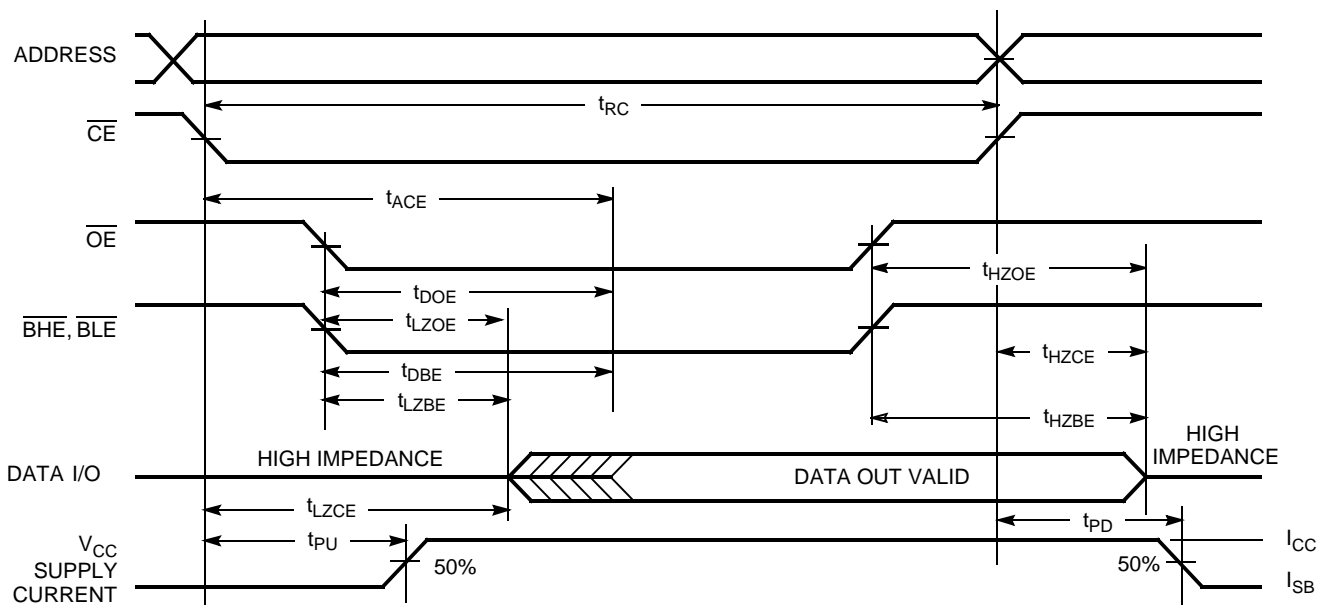

Notes:

- 11. Full device operation requires linear V_{CC} ramp from V_{DR} to $V_{CC(min)}$ $\geq 50\ \mu\text{s}$ or stable at $V_{CC(min)}$ $\geq 50\ \mu\text{s}$.
- 12. Device is continuously selected. \overline{OE} , \overline{CE} , \overline{BHE} and/or $\overline{BLE} = V_{IL}$.
- 13. \overline{WE} is HIGH for Read cycle.
- 14. Address valid prior to or coincident with \overline{CE} transition LOW.

Switching Waveforms (continued)

Write Cycle No. 1 ($\overline{\text{CE}}$ Controlled)^[15, 16]

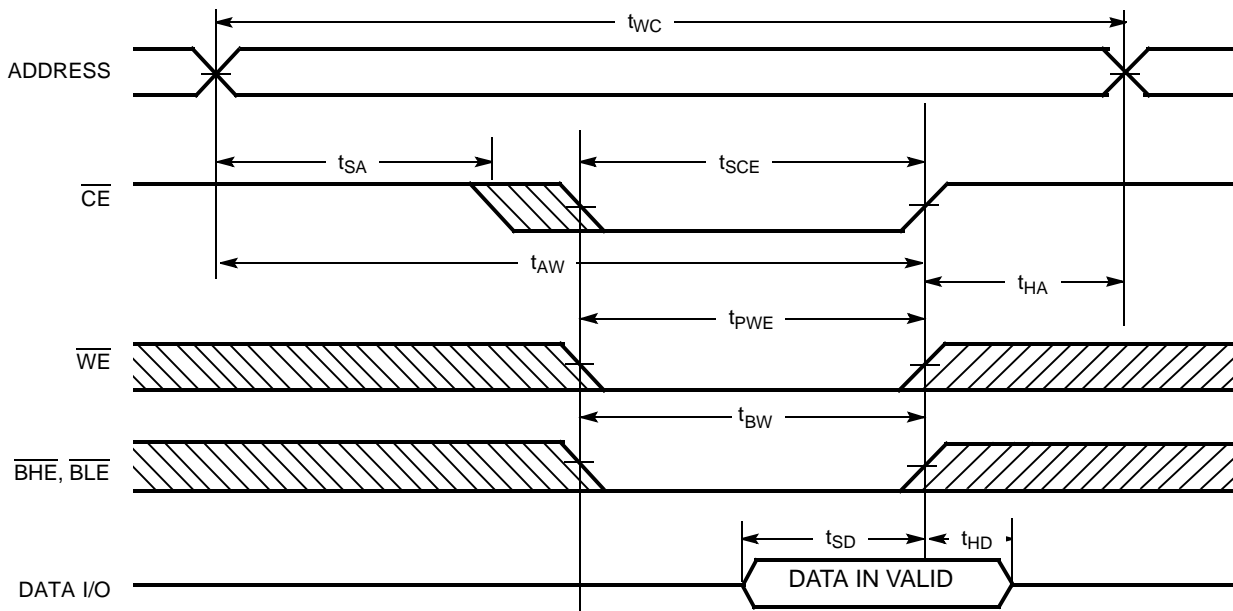

Write Cycle No. 2 ($\overline{\text{BLE}}$ or $\overline{\text{BHE}}$ Controlled)

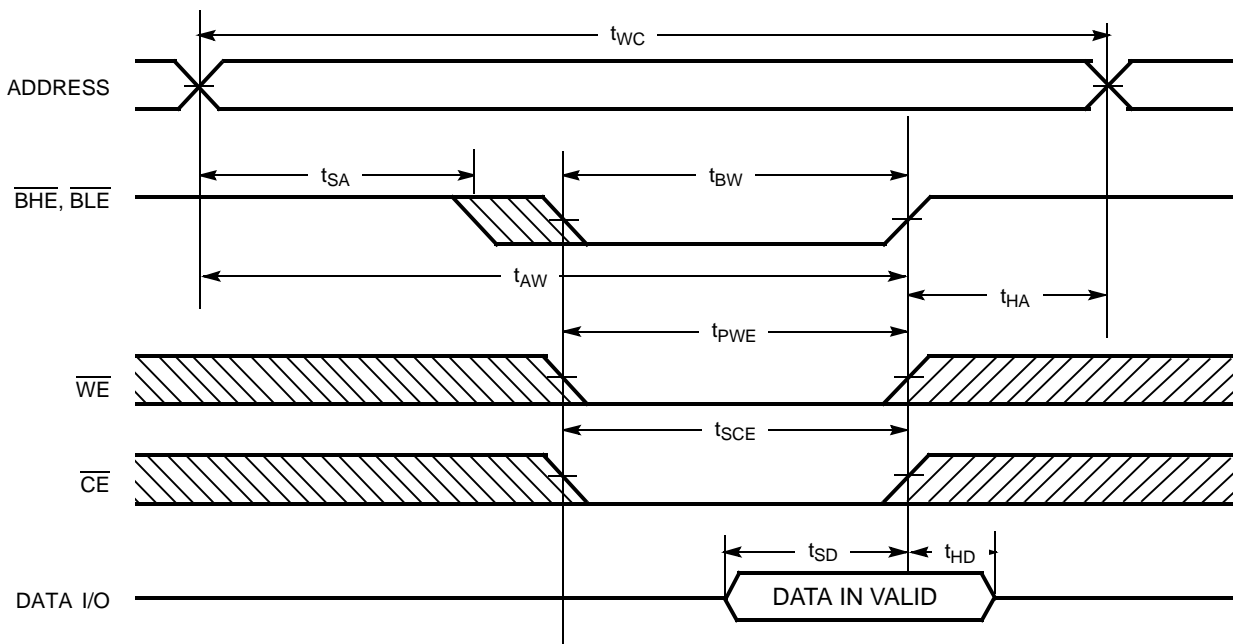

Notes:

15. Data I/O is high impedance if $\overline{\text{OE}}$ or $\overline{\text{BHE}}$ and/or $\overline{\text{BLE}} = V_{IH}$.

16. If $\overline{\text{CE}}$ goes HIGH simultaneously with $\overline{\text{WE}}$ going HIGH, the output remains in a high-impedance state.

Switching Waveforms (continued)

Write Cycle No. 3 (\overline{WE} Controlled, \overline{OE} LOW)

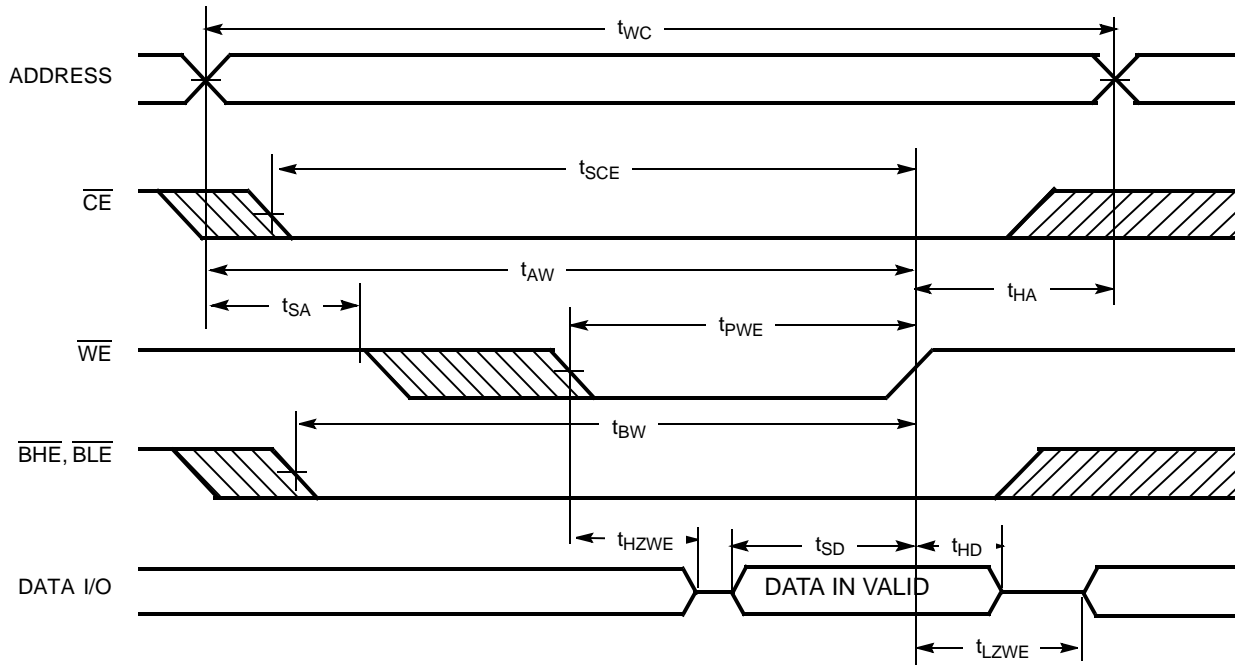

Truth Table

\overline{CE}	\overline{OE}	\overline{WE}	\overline{BLE}	\overline{BHE}	I/O ₀ -I/O ₇	I/O ₈ -I/O ₁₅	Mode	Power
H	X	X	X	X	High-Z	High-Z	Power-down	Standby (I_{SB})
L	L	H	L	L	Data Out	Data Out	Read—All bits	Active (I_{CC})
			L	H	Data Out	High-Z	Read—Lower bits only	Active (I_{CC})
			H	L	High-Z	Data Out	Read—Upper bits only	Active (I_{CC})
L	X	L	L	L	Data In	Data In	Write—All bits	Active (I_{CC})
			L	H	Data In	High-Z	Write—Lower bits only	Active (I_{CC})
			H	L	High-Z	Data In	Write—Upper bits only	Active (I_{CC})
L	H	H	X	X	High-Z	High-Z	Selected, Outputs Disabled	Active (I_{CC})
L	X	X	H	H	High-Z	High-Z	Selected, Outputs Disabled	Active (I_{CC})

Ordering Information

Speed (ns)	Ordering Code	Package Name	Package Type	Operating Range
10	CY7C1020DV33-10VXI	51-85082	44-pin (400-Mil) Molded SOJ (Pb-free)	Industrial
	CY7C1020DV33-10ZSXI	51-85087	44-pin TSOP Type II (Pb-free)	

Ordering Code Definitions

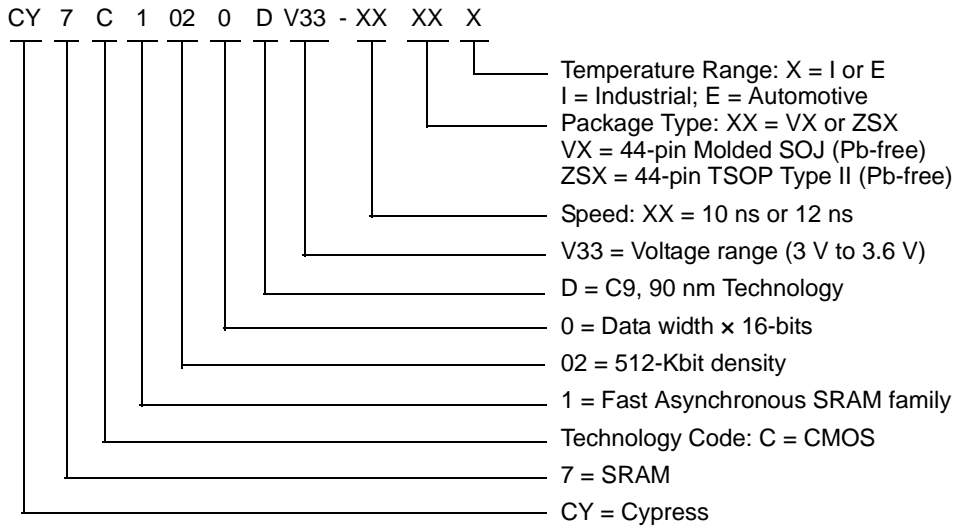

Shaded areas contain advance information. Please contact your local Cypress sales representative for availability of these parts.

Package Diagrams

Figure 1. 44-pin (400-Mil) Molded SOJ (51-85082)

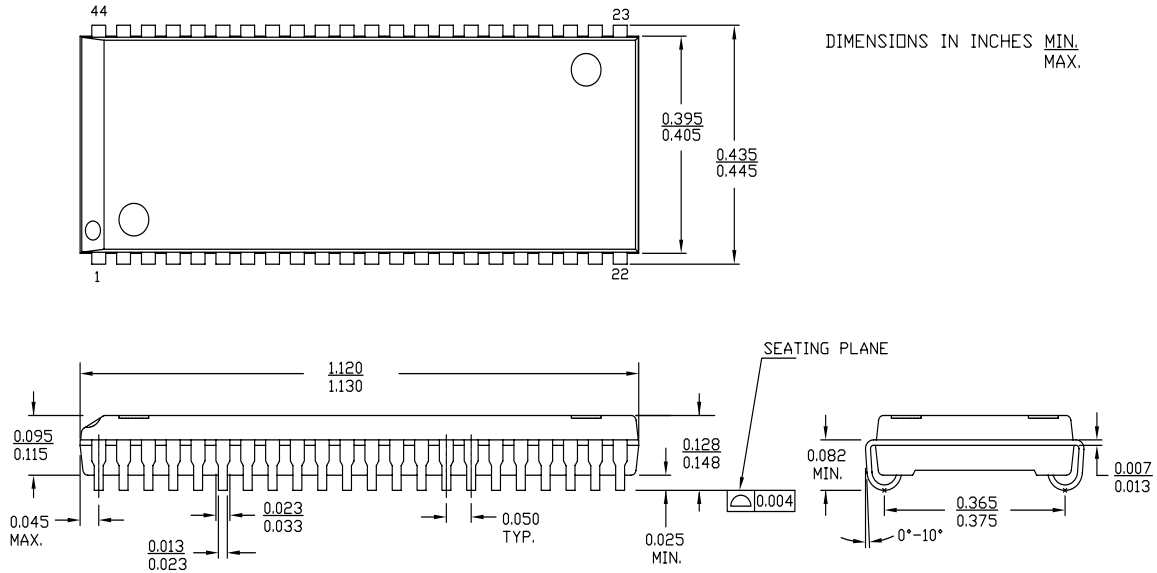

51-85082 *D

Package Diagrams (continued)

Figure 2. 44-Pin Thin Small Outline Package Type II (51-85087)

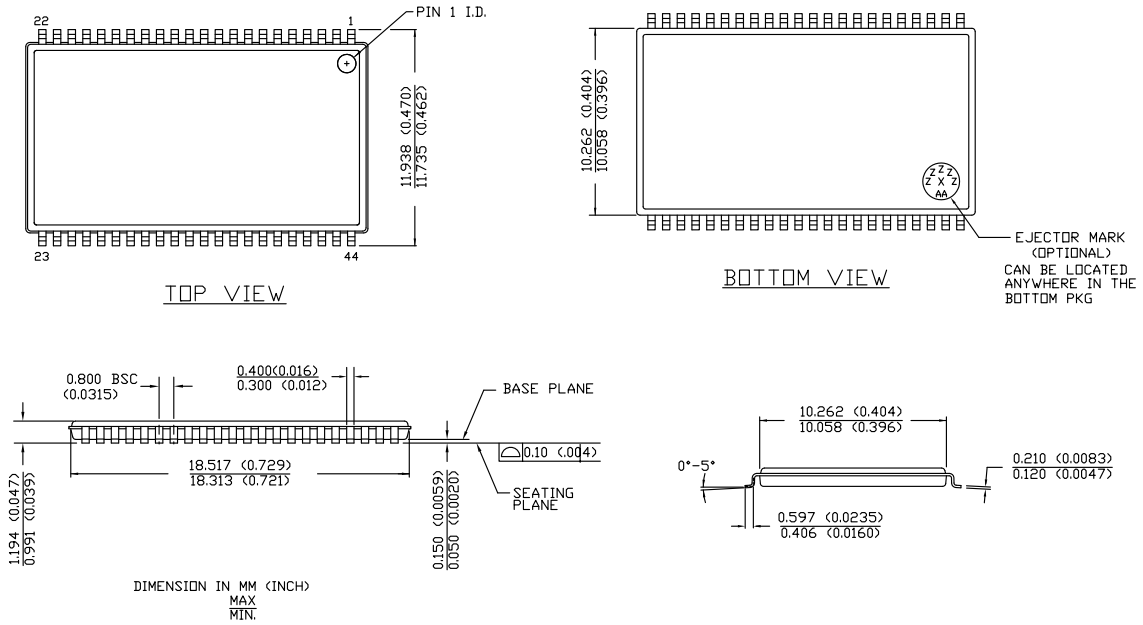

51-85087 *D

Acronyms

Acronym	Description
$\overline{\text{BHE}}$	byte high enable
$\overline{\text{BLE}}$	byte low enable
$\overline{\text{CE}}$	chip enable
CMOS	complementary metal oxide semiconductor
I/O	input/output
$\overline{\text{OE}}$	output enable
SRAM	static random access memory
TSOP	thin small outline package
$\overline{\text{WE}}$	write enable

Document Conventions

Units of Measure

Symbol	Unit of Measure
°C	degrees Celsius
μA	microamperes
mA	milliamperes
MHz	megahertz
ns	nanoseconds
pF	picofarads
V	volts
Ω	ohms
W	watts

Document History Page

Document Title: CY7C1020DV33, 512 K (32 K x 16) Static RAM				
Document Number: 38-05461				
REV.	ECN NO.	Issue Date	Orig. of Change	Description of Change
**	201560	See ECN	SWI	Advance Information data sheet for C9 IPP
*A	233695	See ECN	RKF	DC parameters modified as per EROS (Spec # 01-02165) Pb-free Offering in Ordering Information
*B	262950	See ECN	RKF	Changed I/O ₁ – I/O ₁₆ to I/O ₀ – I/O ₁₅ Added Data Retention Characteristics table Added T _{power} spec in Switching Characteristics table Added 44-SOJ package diagram Shaded Ordering Information
*C	307596	See ECN	RKF	Reduced Speed bins to –8 and –10 ns
*D	560995	See ECN	VKN	Converted from Preliminary to Final Removed Commercial operating range Removed 8 ns speed bin Added Automotive information Added I _{CC} values for the frequencies 83MHz, 66MHz and 40MHz Updated Thermal Resistance table Updated Ordering Information table Changed Overshoot spec from V _{CC} +2 V to V _{CC} +1 V in footnote #4
*E	2898399	03/24/2010	AJU	Updated Package Diagrams
*F	3109992	12/14/2010	AJU	Added Ordering Code Definitions .
*G	3424450	10/28/2011	TAVA	Updated footnotes Updated Selection Guide , Operating Range , Electrical Characteristics Over the Operating Range , Switching Characteristics Over the Operating Range ^[5] , Data Retention Characteristics (Over the Operating Range) , Switching Waveforms , and Ordering Information . Updated Package Diagrams Added Acronyms , and Document Conventions

Sales, Solutions, and Legal Information

Worldwide Sales and Design Support

Cypress maintains a worldwide network of offices, solution centers, manufacturer's representatives, and distributors. To find the office closest to you, visit us at cypress.com/sales.

Products

Automotive	cypress.com/go/automotive
Clocks & Buffers	cypress.com/go/clocks
Interface	cypress.com/go/interface
Lighting & Power Control	cypress.com/go/powerpsoc cypress.com/go/plc
Memory	cypress.com/go/memory
Optical & Image Sensing	cypress.com/go/image
PSoC	cypress.com/go/psoc
Touch Sensing	cypress.com/go/touch
USB Controllers	cypress.com/go/USB
Wireless/RF	cypress.com/go/wireless

PSoC Solutions

psoc.cypress.com/solutions
PSoC 1 | PSoC 3 | PSoC 5

All product and company names mentioned in this document may be the trademarks of their respective holders

© Cypress Semiconductor Corporation, 2008-2011. The information contained herein is subject to change without notice. Cypress Semiconductor Corporation assumes no responsibility for the use of any circuitry other than circuitry embodied in a Cypress product. Nor does it convey or imply any license under patent or other rights. Cypress products are not warranted nor intended to be used for medical, life support, life saving, critical control or safety applications, unless pursuant to an express written agreement with Cypress. Furthermore, Cypress does not authorize its products for use as critical components in life-support systems where a malfunction or failure may reasonably be expected to result in significant injury to the user. The inclusion of Cypress products in life-support systems application implies that the manufacturer assumes all risk of such use and in doing so indemnifies Cypress against all charges.

Any Source Code (software and/or firmware) is owned by Cypress Semiconductor Corporation (Cypress) and is protected by and subject to worldwide patent protection (United States and foreign), United States copyright laws and international treaty provisions. Cypress hereby grants to licensee a personal, non-exclusive, non-transferable license to copy, use, modify, create derivative works of, and compile the Cypress Source Code and derivative works for the sole purpose of creating custom software and or firmware in support of licensee product to be used only in conjunction with a Cypress integrated circuit as specified in the applicable agreement. Any reproduction, modification, translation, compilation, or representation of this Source Code except as specified above is prohibited without the express written permission of Cypress.

Disclaimer: CYPRESS MAKES NO WARRANTY OF ANY KIND, EXPRESS OR IMPLIED, WITH REGARD TO THIS MATERIAL, INCLUDING, BUT NOT LIMITED TO, THE IMPLIED WARRANTIES OF MERCHANTABILITY AND FITNESS FOR A PARTICULAR PURPOSE. Cypress reserves the right to make changes without further notice to the materials described herein. Cypress does not assume any liability arising out of the application or use of any product or circuit described herein. Cypress does not authorize its products for use as critical components in life-support systems where a malfunction or failure may reasonably be expected to result in significant injury to the user. The inclusion of Cypress' product in a life-support systems application implies that the manufacturer assumes all risk of such use and in doing so indemnifies Cypress against all charges.

Use may be limited by and subject to the applicable Cypress software license agreement.