



2K x 8 Automotive Dual-port Static RAM

Features

- True dual-ported memory cells that allow simultaneous reads of the same memory location
- Automotive temperature operation: -40°C to $+115^{\circ}\text{C}$
- 2K x 8 organization
- High-speed access: 55 ns
- Low operating power: $I_{CC} = 120\text{ mA (max.)}$
- Fully asynchronous operation
- Automatic power-down
- Master CG5982AF easily expands data bus width to 16 or more bits using slave
- BUS output flag
- INT flag for port-to-port communication

Functional Description

The CG5982AF are high-speed CMOS 2K x 8 dual-port static RAMs. Two ports are provided to permit independent access to any location in memory. The CG5982AF can be utilized as either a standalone 8-bit dual-port static RAM or as a MASTER dual-port RAM in conjunction with the CG5982AF SLAVE dual-port device in systems requiring 16-bit or greater word widths. It is the solution to applications requiring shared or buffered data such as cache memory for DSP, bit-slice, or multiprocessor designs.

Each port has independent control pins: chip enable ($\overline{\text{CE}}$), write enable (R/W), and output enable ($\overline{\text{OE}}$). BUSY flags are provided on each port. In addition, an interrupt flag (INT) is provided on each port of the 52-pin PLCC version. BUSY signals that the port is trying to access the same location currently being accessed by the other port. On the PLCC version, INT is an interrupt flag indicating that data has been placed in a unique location (7FF for the left port and 7FE for the right port).

An automatic power-down feature is controlled independently on each port by the chip enable ($\overline{\text{CE}}$) pins.

The CG5982AF is available in a 52-pin PLCC package.

Logic Block Diagram

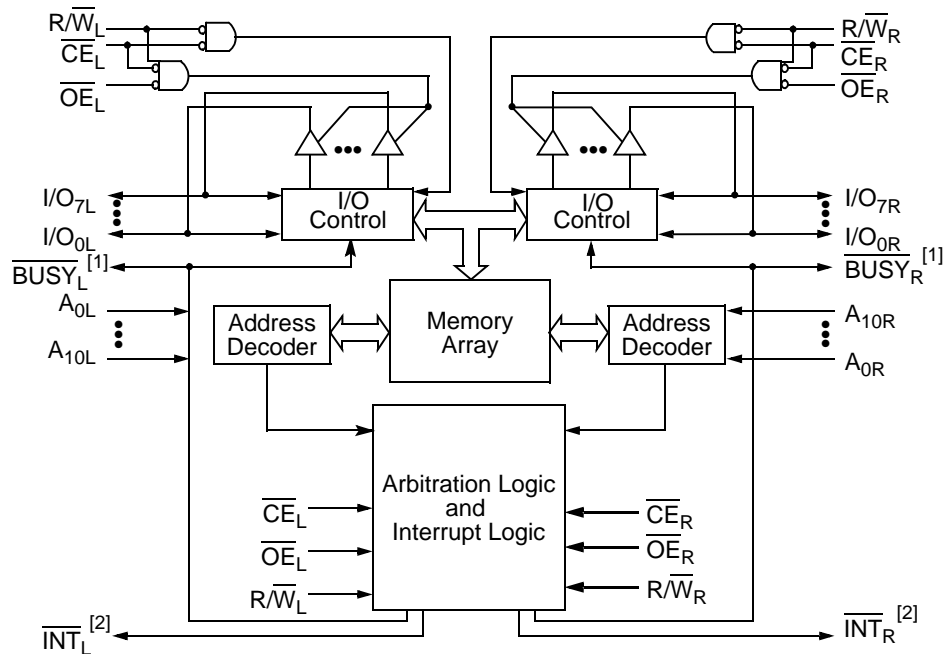

- Notes:**
1. CG5982AF (Master): BUSY is open-drain output and requires pull-up resistor.
 2. Open drain outputs; pull-up resistor required.

Electrical Characteristics Over the Operating Range^[4] (continued)

Parameter	Description	Test Conditions	CG5982AF		Unit	
			Min.	Max.		
I_{CC}	V_{CC} Operating Supply Current	$\overline{CE} = V_{IL}$, Outputs Open, $f = f_{MAX}$ ^[7]	Auto		120	mA
I_{SB1}	Standby Current Both Ports, TTL Inputs	\overline{CE}_L and $\overline{CE}_R \geq V_{IH}$, $f = f_{MAX}$ ^[7]	Auto		45	mA
I_{SB2}	Standby Current One Port, TTL Inputs	\overline{CE}_L or $\overline{CE}_R \geq V_{IH}$, Active Port Outputs Open, $f = f_{MAX}$ ^[7]	Auto		90	mA
I_{SB3}	Standby Current Both Ports, CMOS Inputs	Both Ports \overline{CE}_L and $\overline{CE}_R \geq$ $V_{CC} - 0.2V$, $V_{IN} \geq V_{CC} - 0.2V$ or $V_{IN} \leq 0.2V$, $f = 0$	Auto		15	mA
I_{SB4}	Standby Current One Port, CMOS Inputs	One Port \overline{CE}_L or $\overline{CE}_R \geq V_{CC}$ $- 0.2V$, $V_{IN} \geq V_{CC} - 0.2V$ or $V_{IN} \leq 0.2V$, Active Port Outputs Open, $f = f_{MAX}$ ^[7]	Auto		85	mA

Capacitance^[8]

Parameter	Description	Test Conditions	Max.	Unit
C_{IN}	Input Capacitance	$T_A = 25^\circ C$, $f = 1$ MHz, $V_{CC} = 5.0V$	15	pF
C_{OUT}	Output Capacitance		10	pF

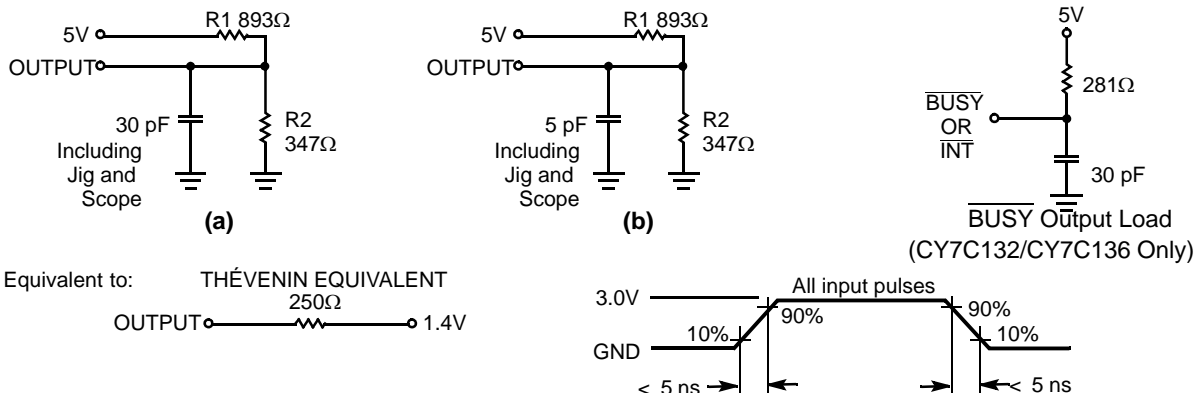
AC Test Loads and Waveforms

Switching Characteristics Over the Operating Range^[4, 9]

Parameter	Description	CG5982AF		Unit
		Min.	Max.	
Read Cycle				
t_{RC}	Read Cycle Time	55		ns
t_{AA}	Address to Data Valid ^[10]		55	ns
t_{OHA}	Data Hold from Address Change	0		ns
t_{ACE}	\overline{CE} LOW to Data Valid ^[10]		55	ns
t_{DOE}	\overline{OE} LOW to Data Valid ^[10]		25	ns
t_{LZOE}	\overline{OE} LOW to Low-Z ^[8, 11]	3		ns

Notes:

- At $f = f_{MAX}$, address and data inputs are cycling at the maximum frequency of read cycle of $1/t_{RC}$ and using AC Test Waveforms input levels of GND to 3V.
- This parameter is guaranteed but not tested.
- Test conditions assume signal transition times of 5 ns or less, timing reference levels of 1.5V, input pulse levels of 0 to 3.0V, output loading of the specified I_{OL}/I_{OH} , and 30-pF load capacitance.
- AC test conditions use $V_{OH} = 1.6V$ and $V_{OL} = 1.4V$.
- At any given temperature and voltage condition for any given device, t_{HZCE} is less than t_{LZCE} and t_{HZOE} is less than t_{LZOE} .

Switching Characteristics Over the Operating Range^[4, 9] (continued)

Parameter	Description	CG5982AF		Unit
		Min.	Max.	
t _{HZOE}	OE HIGH to High-Z ^[8, 11, 12]		25	ns
t _{HZCE}	CE HIGH to High-Z ^[8, 11, 12]		25	ns
t _{PU}	CE LOW to Power-Up ^[8]	0		ns
t _{PD}	CE HIGH to Power-Down ^[8]		35	ns
Write Cycle^[13]				
t _{WC}	Write Cycle Time	55		ns
t _{SCE}	CE LOW to Write End	40		ns
t _{AW}	Address Set-up to Write End	40		ns
t _{HA}	Address Hold from Write End	2		ns
t _{SA}	Address Set-up to Write Start	0		ns
t _{PWE}	R/W Pulse Width	30		ns
t _{SD}	Data Set-up to Write End	20		ns
t _{HD}	Data Hold from Write End	0		ns
t _{HZWE}	R/W LOW to High-Z ^[8]		25	ns
t _{LZWE}	R/W HIGH to Low-Z ^[8]	0		ns
Busy/Interrupt Timing				
t _{BLA}	BUSY LOW from Address Match		30	ns
t _{BHA}	BUSY HIGH from Address Mismatch ^[14]		30	ns
t _{BLC}	BUSY LOW from CE LOW		30	ns
t _{BHC}	BUSY HIGH from CE HIGH ^[14]		30	ns
t _{PS}	Port Set-up for Priority	5		ns
t _{WB}	R/W LOW after BUSY LOW	0		ns
t _{WH}	R/W HIGH after BUSY HIGH	35		ns
t _{BDD}	BUSY HIGH to Valid Data		45	ns
t _{DDD}	Write Data Valid to Read Data Valid		Note 15	ns
t _{WDD}	Write Pulse to Data Delay		Note 15	ns
Interrupt Timing^[15]				
t _{WINS}	R/W to INTERRUPT Set Time		45	ns
t _{EINS}	CE to INTERRUPT Set Time		45	ns
t _{INS}	Address to INTERRUPT Set Time		45	ns
t _{OINR}	OE to INTERRUPT Reset Time ^[14]		45	ns
t _{EINR}	CE to INTERRUPT Reset Time ^[14]		45	ns
t _{INR}	Address to INTERRUPT Reset Time ^[14]		45	ns

Notes:

12. t_{LZCE}, t_{LZWE}, t_{HZOE}, t_{LZOE}, t_{HZCE}, and t_{HZWE} are tested with C_L = 5 pF, as in (b) of AC Test Loads. Transition is measured ± 500 mV from steady-state voltage.
13. The internal write time of the memory is defined by the overlap of CE LOW and R/W LOW. Both signals must be LOW to initiate a write and either signal can terminate a write by going HIGH. The data input setup and hold timing should be referenced to the rising edge of the signal that terminates the write.
14. These parameters are measured from the input signal changing, until the output pin goes to a high-impedance state.
15. A write operation on Port A, where Port A has priority, leaves the data on Port B's outputs undisturbed until one access time after one of the following:
 BUSY on Port B goes HIGH.
 Port B's address toggled.
 CE for Port B is toggled.
 R/W for Port B is toggled during valid read.

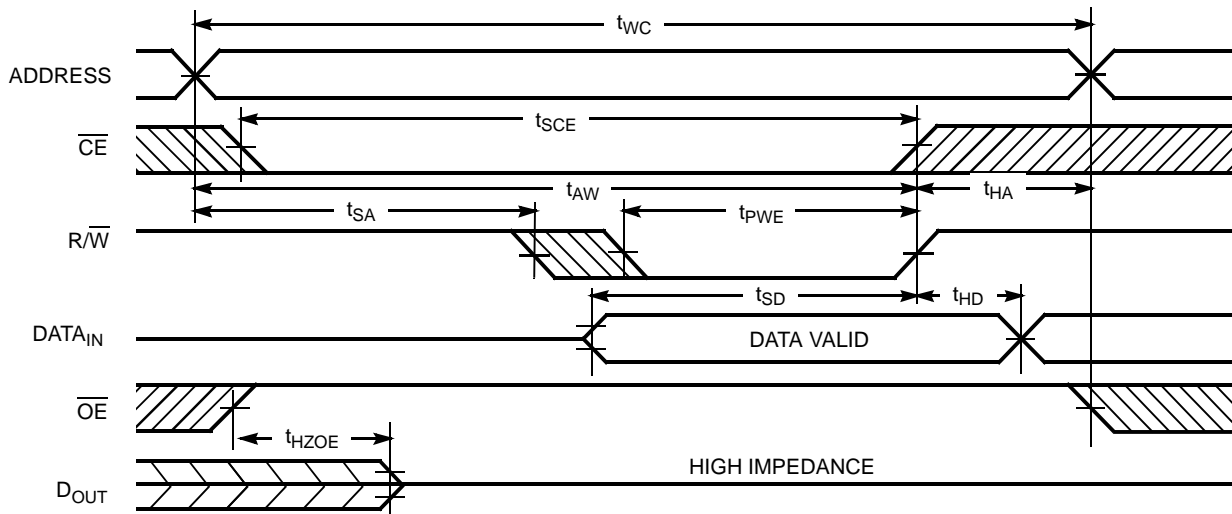
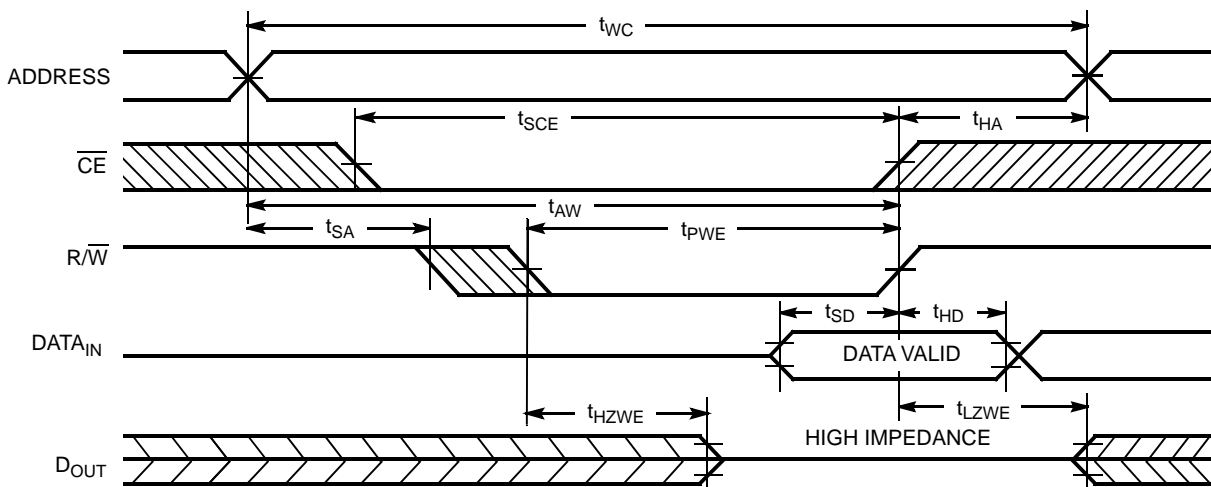
Switching Waveforms (continued)
Write Cycle No.1 (\overline{OE} Three-States Data I/Os—Either Port)^[13, 19]

Write Cycle No. 2 ($\overline{R/W}$ Three-States Data I/Os—Either Port)^[13, 20]

Notes:

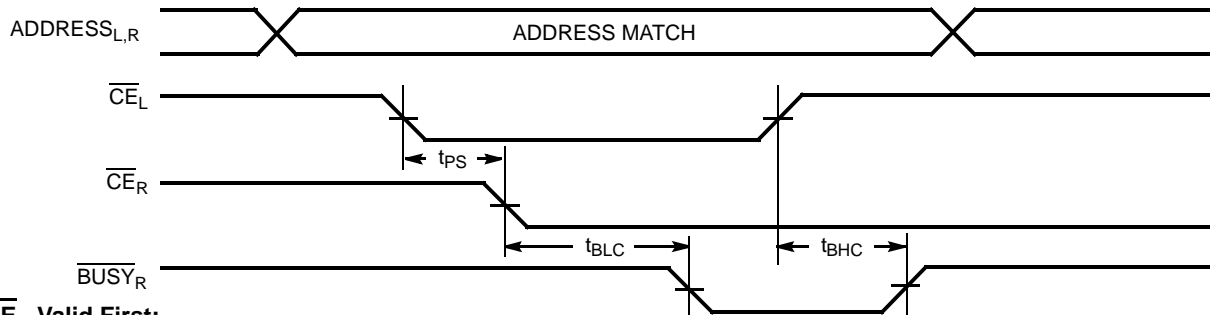
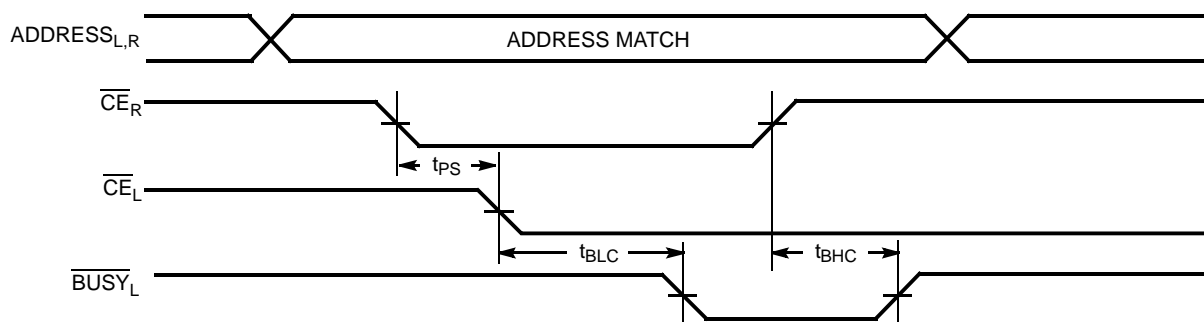
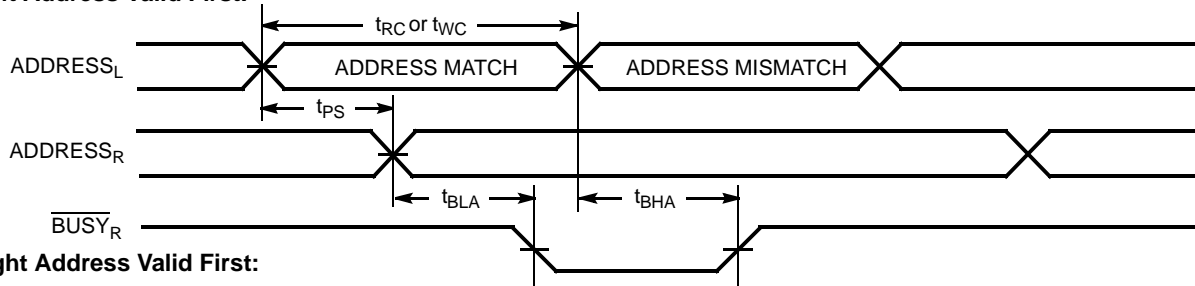
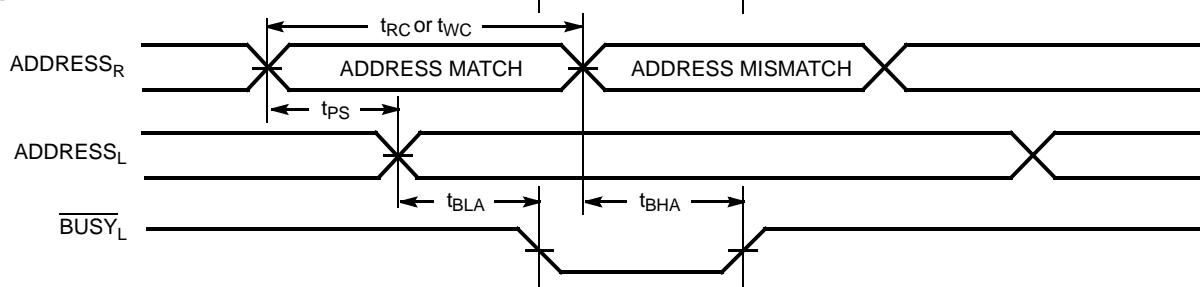
19. If \overline{OE} is LOW during a $\overline{R/W}$ controlled write cycle, the write pulse width must be the larger of t_{PWE} or $t_{HZWE} + t_{SD}$ to allow the data I/O pins to enter high impedance and for data to be placed on the bus for the required t_{SD} .

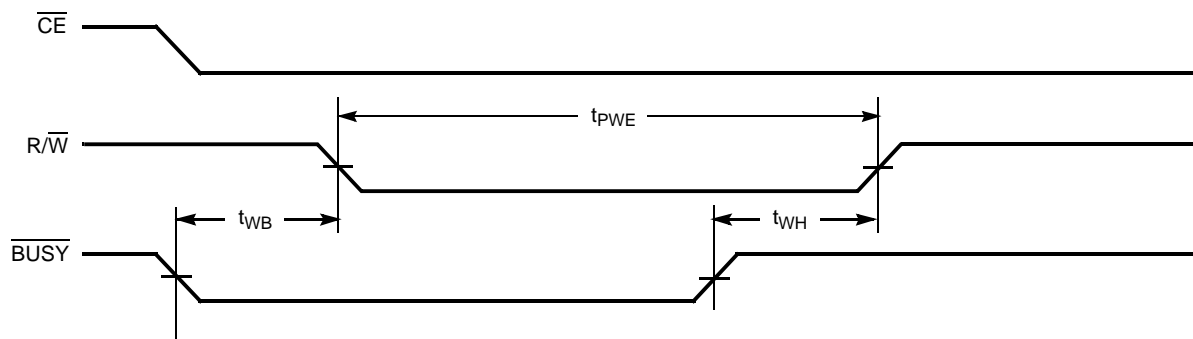
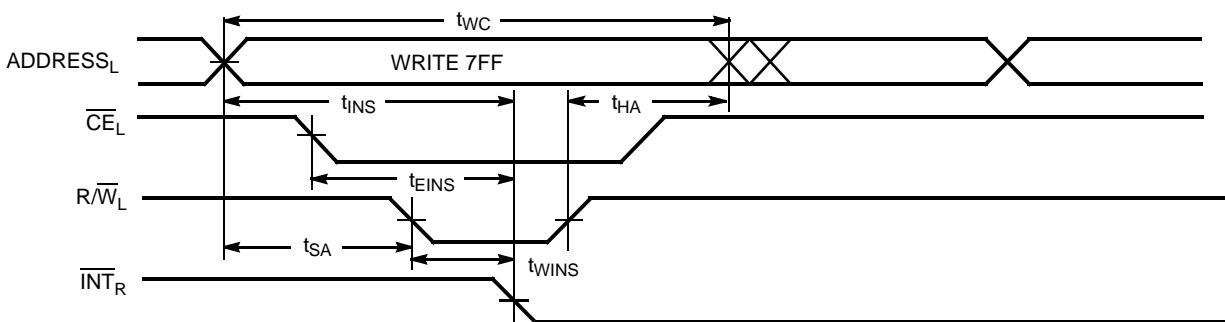
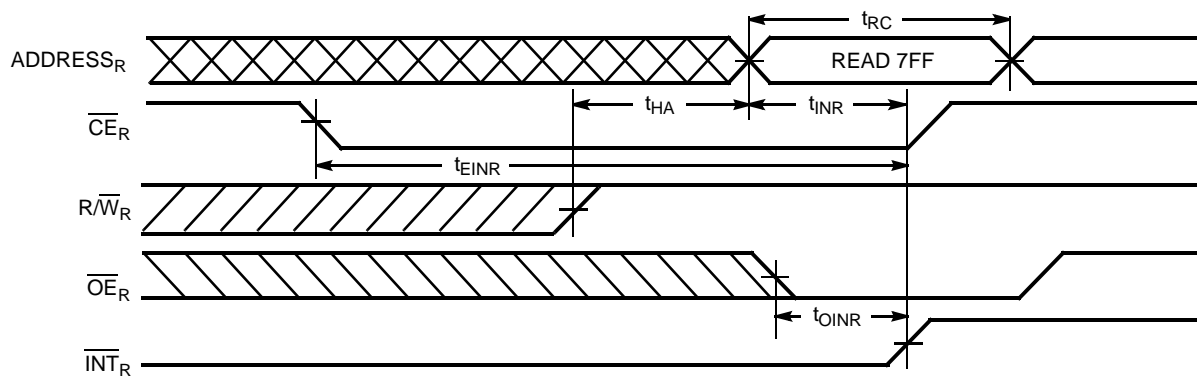
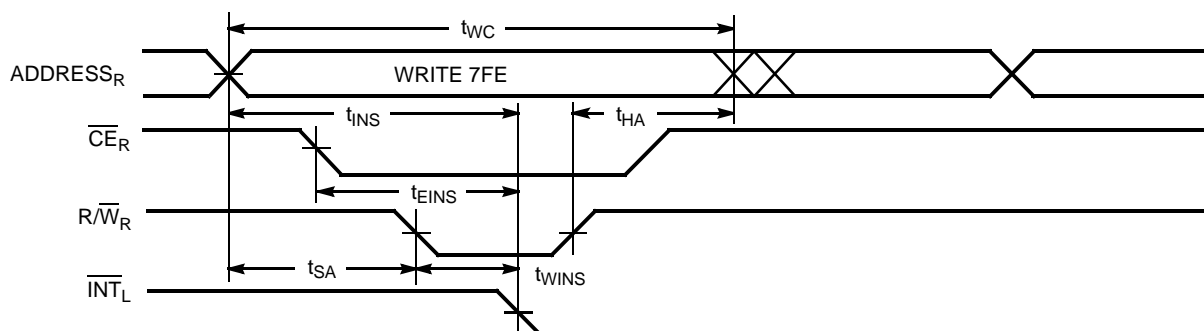
20. If the \overline{CE} LOW transition occurs simultaneously with or after the $\overline{R/W}$ LOW transition, the outputs remain in a high-impedance state.

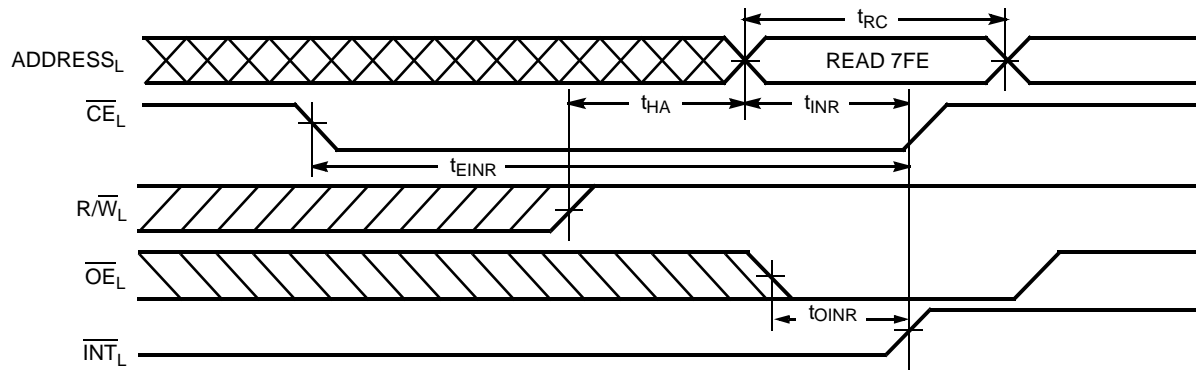
Switching Waveforms (continued)
Busy Timing Diagram No. 1 (\overline{CE} Arbitration)
 \overline{CE}_L Valid First:

 \overline{CE}_R Valid First:

Busy Timing Diagram No. 2 (Address Arbitration)
Left Address Valid First:

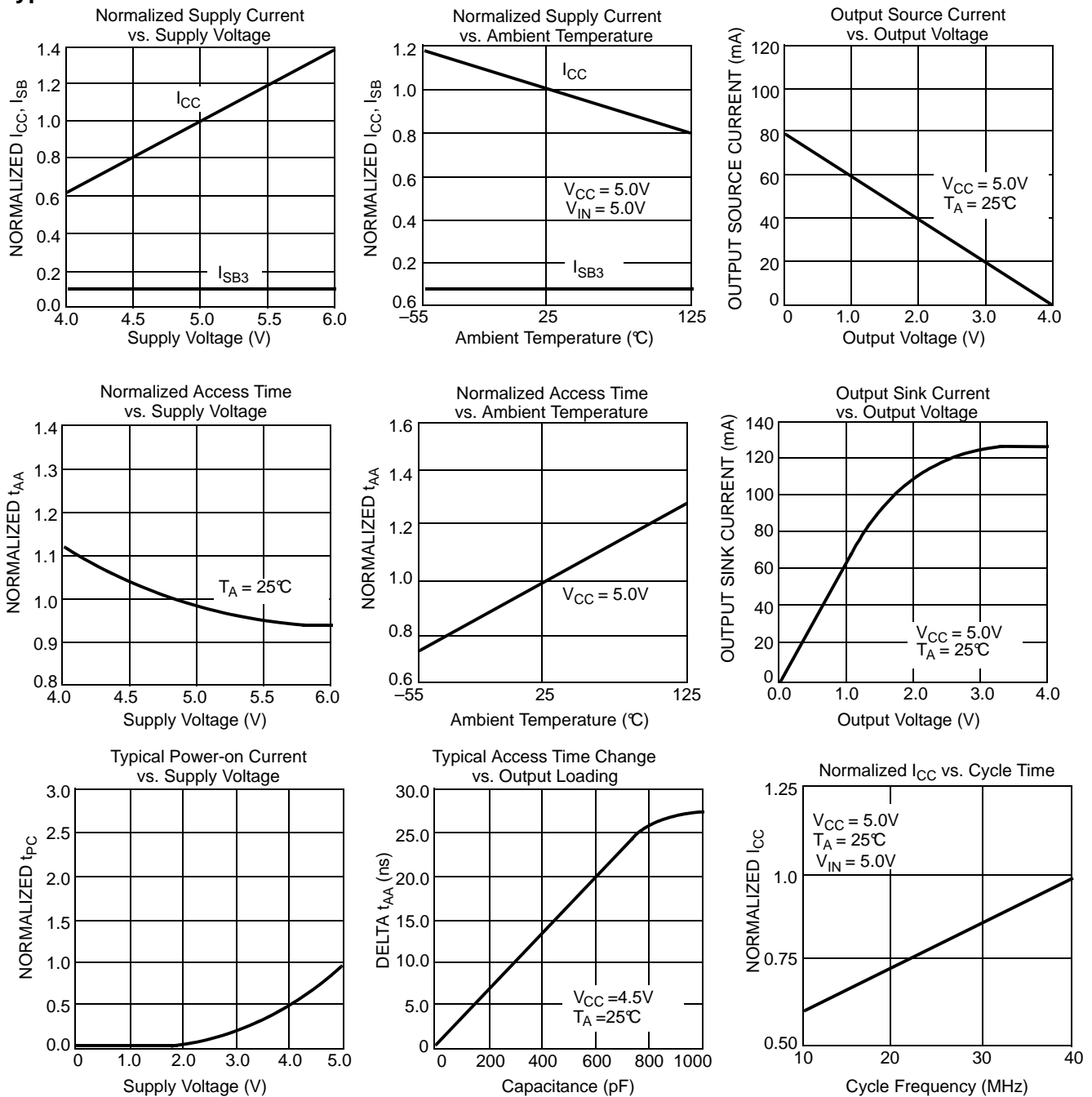
Right Address Valid First:

Switching Waveforms (continued)
Busy Timing Diagram No. 3 (Write with $\overline{\text{BUSY}}$, Slave)

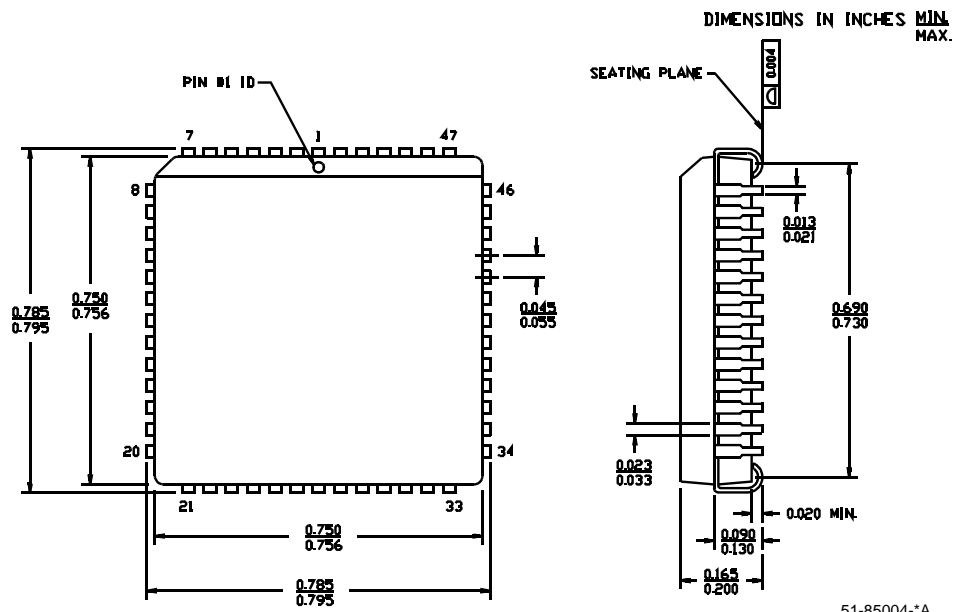
Interrupt Timing Diagrams^[16]
Left Side Sets $\overline{\text{INT}}_R$:

Right Side Clears $\overline{\text{INT}}_R$:

Right Side Sets $\overline{\text{INT}}_L$:

Interrupt Timing Diagrams^[16] (continued)
Left Side Clears $\overline{\text{INT}}_L$:

Typical DC and AC Characteristics

Ordering Information

Speed (ns)	Ordering Code	Package Name	Package Type	Operating Range
55	CG5982AF	J69	52-lead Plastic Leaded Chip Carrier	Automotive

Package Diagrams
52-lead Plastic Leaded Chip Carrier J69

All product and company names mentioned in this document are the trademarks of their respective holders.

Document History Page

Document Title: CG5982AF 2K x 8 Automotive Dual-port Static RAM				
Document Number: 38-06067				
REV.	ECN	Issue Date	Orig. of Change	Description of Change
**	119657	10/10/02	NIM	Customized data sheet to meet special requirements for CG5982AF; automotive temperature -40°C to +115°C; base part in CY7C136
*A	121488	12/09/02	OOR	Fixed Typo- changed 5 mA to 5 μ A (p.2)
*B	393195	SEE ECN	KGH	Included the automotive temperature operation range to the Features section Removed the micron CMOS size and the 52-pin PLCC references from the Features section Added Automotive to the title description
*C	421244	See ECN	ODC	Add to external web.