

# MPC5533

# Microcontroller Data Sheet

by: Microcontroller Division

This document provides electrical specifications, pin assignments, and package diagrams for the MPC5533 microcontroller device. For functional characteristics, refer to the *MPC5534 Microcontroller Reference Manual*.

## 1 Overview

The MPC5533 microcontroller (MCU) is a member of the MPC5500 family of microcontrollers built on the Power Architecture™ embedded technology. This family of parts has many new features coupled with high performance CMOS technology to provide substantial reduction of cost per feature and significant performance improvement over the MPC500 family.

The host processor core of this device complies with the Power Architecture embedded category that is 100% user-mode compatible (including floating point library) with the original Power PC™ user instruction set architecture (UISA). The embedded architecture enhancements improve the performance in embedded applications. The core also has additional instructions, including digital signal processing (DSP) instructions, beyond the original Power PC instruction set.

## Contents

1	Overview	1
2	Ordering Information	3
3	Electrical Characteristics	4
3.1	Maximum Rating	4
3.2	Thermal Characteristics	5
3.3	Package	8
3.4	EMI Characteristics	8
3.5	ESD	9
3.6	VRC and POR Electrical Specifications	9
3.7	Power-Up/Down Sequencing	10
3.8	DC Electrical Specifications	13
3.9	Oscillator and FMPLL Electrical Characteristics	20
3.10	eQADC Electrical Characteristics	22
3.11	H7Fb Flash Memory Electrical Characteristics	23
3.12	AC Specifications	25
3.13	AC Timing	27
4	Mechanicals	43
4.1	MPC5533 208 MAP BGA Pinout	43
4.2	MPC5533 324 PBGA Pinout	44
4.3	MPC5533 208-Pin Package Dimensions	45
4.4	MPC5533 324-Pin Package Dimensions	47
5	Revision History for the MPC5533 Data Sheet	49

## Overview

The MPC5500 family of parts contains many new features coupled with high performance CMOS technology to provide significant performance improvement over the MPC565.

The host processor core of the MPC5533 also includes an instruction set enhancement allowing variable length encoding (VLE). This allows optional encoding of mixed 16- and 32-bit instructions. With this enhancement, it is possible to significantly reduce the code size footprint.

The MPC5533 has a single-level memory hierarchy consisting of 48-kilobytes (KB) on-chip SRAM and 768 KB of internal flash memory. Both the SRAM and the flash memory can hold instructions and data.

The complex input/output timer functions of the MPC5533 are performed by an enhanced time processor unit (eTPU) engine. The eTPU engine controls 32 hardware channels. The eTPU has been enhanced over the TPU by providing: 24-bit timers, double-action hardware channels, variable number of parameters per channel, angle clock hardware, and additional control and arithmetic instructions. The eTPU is programmed using a high-level programming language.

Off-chip communication is performed by a suite of serial protocols including controller area networks (FlexCANs), enhanced deserial/serial peripheral interfaces (DSPIs), and an enhanced serial communications interface (eSCI).

The MCU has an on-chip enhanced queued analog-to-digital converter (eQADC) with a 5 V conversion range. The 324 package has 40-channels; the 208 package has 34 channels.

The system integration unit (SIU) performs several chip-wide configuration functions. Pad configuration and general-purpose input and output (GPIO) are controlled from the SIU. Interrupts and reset control are also determined by the SIU. The internal multiplexer sub-block (IMUX) provides multiplexing of eQADC trigger sources and external interrupt signal multiplexing.

## 2 Ordering Information

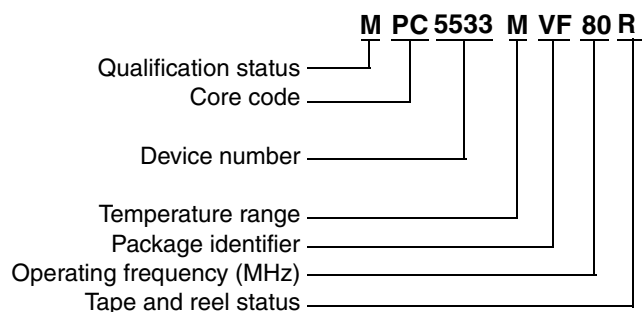

**Temperature Range**  
M = -40° C to 125° C

**Package Identifier**  
VF = 208MAPBGA SnPb  
VM = 208MAPBGA Pb-free  
ZQ = 324PBGA SnPb  
VZ = 324PBGA Pb-free

**Operating Frequency**  
40 = 40 MHz  
66 = 66 MHz  
80 = 80 MHz

**Tape and Reel Status**  
R = Tape and reel  
(blank) = Trays

**Qualification Status**

P = Pre qualification  
M = Fully spec. qualified, general market flow  
S = Fully spec. qualified, automotive flow

**Note:** Not all options are available on all devices. Refer to [Table 1](#).

**Figure 1. MPC5500 Family Part Number Example**

Unless noted in this data sheet, all specifications apply from  $T_L$  to  $T_H$ .

**Table 1. Orderable Part Numbers**

Freescale Part Number	Package Description	Speed (MHz)		Operating Temperature <sup>1</sup>	
		Nominal	Max. <sup>2</sup> ( $f_{MAX}$ )	Min. ( $T_L$ )	Max. ( $T_H$ )
MPC5533MVM80	MPC5533 208 package Lead-free (PbFree)	80	82	-40° C	125° C
MPC5533MVM66		66	68		
MPC5533MVM40		40	42		
MPC5533MVF80	MPC5533 208 package Leaded (SnPb)	80	82	-40° C	125° C
MPC5533MVF66		66	68		
MPC5533MVF40		40	42		
MPC5533MVZ80	MPC5533 324 package Lead-free (PbFree)	80	82	-40° C	125° C
MPC5533MVZ66		66	68		
MPC5533MVZ40		40	42		
MPC5533MZQ80	MPC5533 324 package Leaded (SnPb)	80	82	-40° C	125° C
MPC5533MZQ66		66	68		
MPC5533MZQ40		40	42		

<sup>1</sup> The lowest ambient operating temperature is referenced by  $T_L$ ; the highest ambient operating temperature is referenced by  $T_H$ .

<sup>2</sup> Speed is the nominal maximum frequency. Max. speed is the maximum speed allowed including frequency modulation (FM). 42 MHz parts allow for 40 MHz system clock + 2% FM; 68 MHz parts allow for 66 MHz system clock + 2% FM, and 82 MHz parts allow for 80 MHz system clock + 2% FM.

### 3 Electrical Characteristics

This section contains detailed information on power considerations, DC/AC electrical characteristics, and AC timing specifications for the MCU.

#### 3.1 Maximum Rating

Table 2. Absolute Maximum Ratings <sup>1</sup>

Spec	Characteristic	Symbol	Min.	Max.	Unit
1	1.5 V core supply voltage <sup>2</sup>	$V_{DD}$	-0.3	1.7	V
2	Flash program/erase voltage	$V_{PP}$	-0.3	6.5	V
4	Flash read voltage	$V_{FLASH}$	-0.3	4.6	V
5	SRAM standby voltage	$V_{STBY}$	-0.3	1.7	V
6	Clock synthesizer voltage	$V_{DDSYN}$	-0.3	4.6	V
7	3.3 V I/O buffer voltage	$V_{DD33}$	-0.3	4.6	V
8	Voltage regulator control input voltage	$V_{RC33}$	-0.3	4.6	V
9	Analog supply voltage (reference to $V_{SSA}$ )	$V_{DDA}$	-0.3	5.5	V
10	I/O supply voltage (fast I/O pads) <sup>3</sup>	$V_{DDE}$	-0.3	4.6	V
11	I/O supply voltage (slow and medium I/O pads) <sup>3</sup>	$V_{DDEH}$	-0.3	6.5	V
12	DC input voltage <sup>4</sup> $V_{DDEH}$ powered I/O pads $V_{DDE}$ powered I/O pads	$V_{IN}$	-1.0 <sup>5</sup> -1.0 <sup>5</sup>	6.5 <sup>6</sup> 4.6 <sup>7</sup>	V
13	Analog reference high voltage (reference to $V_{RL}$ )	$V_{RH}$	-0.3	5.5	V
14	$V_{SS}$ to $V_{SSA}$ differential voltage	$V_{SS} - V_{SSA}$	-0.1	0.1	V
15	$V_{DD}$ to $V_{DDA}$ differential voltage	$V_{DD} - V_{DDA}$	$-V_{DDA}$	$V_{DD}$	V
16	$V_{REF}$ differential voltage	$V_{RH} - V_{RL}$	-0.3	5.5	V
17	$V_{RH}$ to $V_{DDA}$ differential voltage	$V_{RH} - V_{DDA}$	-5.5	5.5	V
18	$V_{RL}$ to $V_{SSA}$ differential voltage	$V_{RL} - V_{SSA}$	-0.3	0.3	V
19	$V_{DDEH}$ to $V_{DDA}$ differential voltage	$V_{DDEH} - V_{DDA}$	$-V_{DDA}$	$V_{DDEH}$	V
20	$V_{DDF}$ to $V_{DD}$ differential voltage	$V_{DDF} - V_{DD}$	-0.3	0.3	V
21	$V_{RC33}$ to $V_{DDSYN}$ differential voltage spec has been moved to <a href="#">Table 9 DC Electrical Specifications, Spec 43a</a> .				
22	$V_{SSSYN}$ to $V_{SS}$ differential voltage	$V_{SSSYN} - V_{SS}$	-0.1	0.1	V
23	$V_{RCVSS}$ to $V_{SS}$ differential voltage	$V_{RCVSS} - V_{SS}$	-0.1	0.1	V
24	Maximum DC digital input current <sup>8</sup> (per pin, applies to all digital pins) <sup>4</sup>	$I_{MAXD}$	-2	2	mA
25	Maximum DC analog input current <sup>9</sup> (per pin, applies to all analog pins)	$I_{MAXA}$	-3	3	mA
26	Maximum operating temperature range <sup>10</sup> Die junction temperature	$T_J$	$T_L$	150.0	°C
27	Storage temperature range	$T_{STG}$	-55.0	150.0	°C

Table 2. Absolute Maximum Ratings <sup>1</sup> (continued)

Spec	Characteristic	Symbol	Min.	Max.	Unit
28	Maximum solder temperature <sup>11</sup> Lead free (Pb-free) Leaded (SnPb)	T <sub>SDR</sub>	— —	260.0 245.0	°C
29	Moisture sensitivity level <sup>12</sup>	MSL	—	3	

<sup>1</sup> Functional operating conditions are given in the DC electrical specifications. Absolute maximum ratings are stress ratings only, and functional operation at the maxima is not guaranteed. Stress beyond any of the listed maxima can affect device reliability or cause permanent damage to the device.

<sup>2</sup> 1.5 V ± 10% for proper operation. This parameter is specified at a maximum junction temperature of 150 °C.

<sup>3</sup> All functional non-supply I/O pins are clamped to V<sub>SS</sub> and V<sub>DDE</sub>, or V<sub>DDEH</sub>.

<sup>4</sup> AC signal overshoot and undershoot of up to ± 2.0 V of the input voltages is permitted for an accumulative duration of 60 hours over the complete lifetime of the device (injection current not limited for this duration).

<sup>5</sup> Internal structures hold the voltage greater than –1.0 V if the injection current limit of 2 mA is met. Keep the negative DC voltage greater than –0.6 V on SINB during the internal power-on reset (POR) state.

<sup>6</sup> Internal structures hold the input voltage less than the maximum voltage on all pads powered by V<sub>DDEH</sub> supplies, if the maximum injection current specification is met (2 mA for all pins) and V<sub>DDEH</sub> is within the operating voltage specifications.

<sup>7</sup> Internal structures hold the input voltage less than the maximum voltage on all pads powered by V<sub>DDE</sub> supplies, if the maximum injection current specification is met (2 mA for all pins) and V<sub>DDE</sub> is within the operating voltage specifications.

<sup>8</sup> Total injection current for all pins (including both digital and analog) must not exceed 25 mA.

<sup>9</sup> Total injection current for all analog input pins must not exceed 15 mA.

<sup>10</sup> Lifetime operation at these specification limits is not guaranteed.

<sup>11</sup> Moisture sensitivity profile per IPC/JEDEC J-STD-020D.

<sup>12</sup> Moisture sensitivity per JEDEC test method A112.

## 3.2 Thermal Characteristics

The shaded rows in the following table indicate information specific to a four-layer board.

Table 3. MPC5533 Thermal Characteristic

Spec	MPC5533 Thermal Characteristic	Symbol	Package		Unit
			208 MAPBGA	324 PBGA	
1	Junction to ambient <sup>1, 2</sup> , natural convection (one-layer board)	R <sub>θJA</sub>	42	34	°C/W
2	Junction to ambient <sup>1, 3</sup> , natural convection (four-layer board 2s2p)	R <sub>θJA</sub>	26	23	°C/W
3	Junction to ambient (@200 ft./min., one-layer board)	R <sub>θJMA</sub>	34	28	°C/W
4	Junction to ambient (@200 ft./min., four-layer board 2s2p)	R <sub>θJMA</sub>	22	20	°C/W
5	Junction to board <sup>4</sup> (four-layer board 2s2p)	R <sub>θJB</sub>	15	15	°C/W
6	Junction to case <sup>5</sup>	R <sub>θJC</sub>	8	10	°C/W
7	Junction to package top <sup>6</sup> , natural convection	Ψ <sub>JT</sub>	2	2	°C/W

<sup>1</sup> Junction temperature is a function of: on-chip power dissipation, package thermal resistance, mounting site (board) temperature, ambient temperature, air flow, power dissipation of other board components, and board thermal resistance.

<sup>2</sup> Per SEMI G38-87 and JEDEC JESD51-2 with the single-layer board in a horizontal position.

<sup>3</sup> Per JEDEC JESD51-6 with the board in a horizontal position.

<sup>4</sup> Thermal resistance between the die and the printed circuit board per JEDEC JESD51-8. Board temperature is measured on the top surface of the board near the package.

## Electrical Characteristics

- <sup>5</sup> Indicates the average thermal resistance between the die and the case top surface as measured by the cold plate method (MIL SPEC-883 Method 1012.1) with the cold plate temperature used for the case temperature.
- <sup>6</sup> The thermal characterization parameter indicates the temperature difference between the package top and the junction temperature per JEDEC JESD51-2.

### 3.2.1 General Notes for Specifications at Maximum Junction Temperature

An estimation of the device junction temperature,  $T_J$ , can be obtained from the equation:

$$T_J = T_A + (R_{\theta JA} \times P_D)$$

where:

$T_A$  = ambient temperature for the package ( $^{\circ}\text{C}$ )

$R_{\theta JA}$  = junction to ambient thermal resistance ( $^{\circ}\text{C}/\text{W}$ )

$P_D$  = power dissipation in the package (W)

The thermal resistance values used are based on the JEDEC JESD51 series of standards to provide consistent values for estimations and comparisons. The difference between the values determined for the single-layer (1s) board compared to a four-layer board that has two signal layers, a power and a ground plane (2s2p), demonstrate that the effective thermal resistance is not a constant. The thermal resistance depends on the:

- Construction of the application board (number of planes)
- Effective size of the board which cools the component
- Quality of the thermal and electrical connections to the planes
- Power dissipated by adjacent components

Connect all the ground and power balls to the respective planes with one via per ball. Using fewer vias to connect the package to the planes reduces the thermal performance. Thinner planes also reduce the thermal performance. When the clearance between the vias leave the planes virtually disconnected, the thermal performance is also greatly reduced.

As a general rule, the value obtained on a single-layer board is within the normal range for the tightly packed printed circuit board. The value obtained on a board with the internal planes is usually within the normal range if the application board has:

- One oz. (35 micron nominal thickness) internal planes
- Components are well separated
- Overall power dissipation on the board is less than  $0.02 \text{ W}/\text{cm}^2$

The thermal performance of any component depends on the power dissipation of the surrounding components. In addition, the ambient temperature varies widely within the application. For many natural convection and especially closed box applications, the board temperature at the perimeter (edge) of the package is approximately the same as the local air temperature near the device. Specifying the local ambient conditions explicitly as the board temperature provides a more precise description of the local ambient conditions that determine the temperature of the device.

At a known board temperature, the junction temperature is estimated using the following equation:

$$T_J = T_B + (R_{\theta JB} \times P_D)$$

where:

$T_J$  = junction temperature ( $^{\circ}\text{C}$ )

$T_B$  = board temperature at the package perimeter ( $^{\circ}\text{C/W}$ )

$R_{\theta JB}$  = junction-to-board thermal resistance ( $^{\circ}\text{C/W}$ ) per JESD51-8

$P_D$  = power dissipation in the package (W)

When the heat loss from the package case to the air does not factor into the calculation, an acceptable value for the junction temperature is predictable. Ensure the application board is similar to the thermal test condition, with the component soldered to a board with internal planes.

The thermal resistance is expressed as the sum of a junction-to-case thermal resistance plus a case-to-ambient thermal resistance:

$$R_{\theta JA} = R_{\theta JC} + R_{\theta CA}$$

where:

$R_{\theta JA}$  = junction-to-ambient thermal resistance ( $^{\circ}\text{C/W}$ )

$R_{\theta JC}$  = junction-to-case thermal resistance ( $^{\circ}\text{C/W}$ )

$R_{\theta CA}$  = case-to-ambient thermal resistance ( $^{\circ}\text{C/W}$ )

$R_{\theta JC}$  is device related and is not affected by other factors. The thermal environment can be controlled to change the case-to-ambient thermal resistance,  $R_{\theta CA}$ . For example, change the air flow around the device, add a heat sink, change the mounting arrangement on the printed circuit board, or change the thermal dissipation on the printed circuit board surrounding the device. This description is most useful for packages with heat sinks where 90% of the heat flow is through the case to heat sink to ambient. For most packages, a better model is required.

A more accurate two-resistor thermal model can be constructed from the junction-to-board thermal resistance and the junction-to-case thermal resistance. The junction-to-case thermal resistance describes when using a heat sink or where a substantial amount of heat is dissipated from the top of the package. The junction-to-board thermal resistance describes the thermal performance when most of the heat is conducted to the printed circuit board. This model can be used to generate simple estimations and for computational fluid dynamics (CFD) thermal models.

To determine the junction temperature of the device in the application on a prototype board, use the thermal characterization parameter ( $\Psi_{JT}$ ) to determine the junction temperature by measuring the temperature at the top center of the package case using the following equation:

$$T_J = T_T + (\Psi_{JT} \times P_D)$$

where:

$T_T$  = thermocouple temperature on top of the package ( $^{\circ}\text{C}$ )

$\Psi_{JT}$  = thermal characterization parameter ( $^{\circ}\text{C/W}$ )

$P_D$  = power dissipation in the package (W)

The thermal characterization parameter is measured in compliance with the JESD51-2 specification using a 40-gauge type T thermocouple epoxied to the top center of the package case. Position the thermocouple

## Electrical Characteristics

so that the thermocouple junction rests on the package. Place a small amount of epoxy on the thermocouple junction and approximately 1 mm of wire extending from the junction. Place the thermocouple wire flat against the package case to avoid measurement errors caused by the cooling effects of the thermocouple wire.

### References:

Semiconductor Equipment and Materials International  
3081 Zanker Rd.  
San Jose, CA., 95134  
(408) 943-6900

MIL-SPEC and EIA/JESD (JEDEC) specifications are available from Global Engineering Documents at 800-854-7179 or 303-397-7956.

JEDEC specifications are available on the web at <http://www.jedec.org>.

- 1. C.E. Triplett and B. Joiner, “An Experimental Characterization of a 272 PBGA Within an Automotive Engine Controller Module,” Proceedings of SemiTherm, San Diego, 1998, pp. 47–54.
- 2. G. Kromann, S. Shidore, and S. Addison, “Thermal Modeling of a PBGA for Air-Cooled Applications,” Electronic Packaging and Production, pp. 53–58, March 1998.
- 3. B. Joiner and V. Adams, “Measurement and Simulation of Junction to Board Thermal Resistance and Its Application in Thermal Modeling,” Proceedings of SemiTherm, San Diego, 1999, pp. 212–220.

## 3.3 Package

The MPC5533 is available in packaged form. Read the package options in [Section 2, “Ordering Information.”](#) Refer to [Section 4, “Mechanicals,”](#) for pinouts and package drawings.

## 3.4 EMI (Electromagnetic Interference) Characteristics

Table 4. EMI Testing Specifications <sup>1</sup>

Spec	Characteristic	Minimum	Typical	Maximum	Unit
1	Scan range	0.15	—	1000	MHz
2	Operating frequency	—	—	f <sub>MAX</sub>	MHz
3	V <sub>DD</sub> operating voltages	—	1.5	—	V
4	V <sub>DDSYN</sub> , V <sub>RC33</sub> , V <sub>DD33</sub> , V <sub>FLASH</sub> , V <sub>DDE</sub> operating voltages	—	3.3	—	V
5	V <sub>PP</sub> , V <sub>DDEH</sub> , V <sub>DDA</sub> operating voltages	—	5.0	—	V
6	Maximum amplitude	—	—	14 <sup>2</sup> 32 <sup>3</sup>	dBuV
7	Operating temperature	—	—	25	°C

<sup>1</sup> EMI testing and I/O port waveforms per SAE J1752/3 issued 1995-03. Qualification testing was performed on the MPC5554 and applied to the MPC5500 family as generic EMI performance data.

<sup>2</sup> Measured with the single-chip EMI program.

<sup>3</sup> Measured with the expanded EMI program.



### 3.5 ESD (Electromagnetic Static Discharge) Characteristics

Table 5. ESD Ratings <sup>1, 2</sup>

Characteristic	Symbol	Value	Unit
ESD for human body model (HBM)		2000	V
HBM circuit description	R1	1500	$\Omega$
	C	100	pF
ESD for field induced charge model (FDCM)		500 (all pins)	V
		750 (corner pins)	
Number of pulses per pin:			
Positive pulses (HBM)	—	1	—
Negative pulses (HBM)	—	1	—
Interval of pulses	—	1	second

<sup>1</sup> All ESD testing conforms to CDF-AEC-Q100 Stress Test Qualification for Automotive Grade Integrated Circuits.

<sup>2</sup> Device failure is defined as: 'If after exposure to ESD pulses, the device does not meet the device specification requirements, which includes the complete DC parametric and functional testing at room temperature and hot temperature.'

### 3.6 Voltage Regulator Controller ( $V_{RC}$ ) and Power-On Reset (POR) Electrical Specifications

The following table lists the  $V_{RC}$  and POR electrical specifications:

Table 6. VRC/POR Electrical Specifications

Spec	Characteristic		Symbol	Min.	Max.	Units
1	1.5 V ( $V_{DD}$ ) POR <sup>1</sup>	Negated (ramp up) Asserted (ramp down)	$V_{POR15}$	1.1 1.1	1.35 1.35	V
2	3.3 V ( $V_{DDSYN}$ ) POR <sup>1</sup>	Asserted (ramp up) Negated (ramp up) Asserted (ramp down) Negated (ramp down)	$V_{POR33}$	0.0 2.0 2.0 0.0	0.30 2.85 2.85 0.30	V
3	$\overline{RESET}$ pin supply ( $V_{DDEH6}$ ) POR <sup>1, 2</sup>	Negated (ramp up) Asserted (ramp down)	$V_{POR5}$	2.0 2.0	2.85 2.85	V
4	$V_{RC33}$ voltage	Before $V_{RC}$ allows the pass transistor to start turning on	$V_{TRANS\_START}$	1.0	2.0	V
5		When $V_{RC}$ allows the pass transistor to completely turn on <sup>3, 4</sup>	$V_{TRANS\_ON}$	2.0	2.85	V
6		When the voltage is greater than the voltage at which the $V_{RC}$ keeps the 1.5 V supply in regulation <sup>5, 6</sup>	$V_{VRC33REG}$	3.0	—	V
7	Current can be sourced by $V_{RCCTL}$ at $T_j$ :	– 40° C 25° C 150° C	$I_{VRCCTL}$ <sup>7</sup>	11.0 9.0 7.5	— — —	mA mA mA
8	Voltage differential during power up such that: $V_{DD33}$ can lag $V_{DDSYN}$ or $V_{DDEH6}$ , before $V_{DDSYN}$ and $V_{DDEH6}$ reach the $V_{POR33}$ and $V_{POR5}$ minimums respectively.		$V_{DD33\_LAG}$	—	1.0	V

Table 6. VRC/POR Electrical Specifications (continued)

Spec	Characteristic		Symbol	Min.	Max.	Units
9	Absolute value of slew rate on power supply pins		—	—	50	V/ms
10	Required gain at Tj:	– 40° C	BETA <sup>10</sup>	35	—	—
	$I_{DD} \div I_{VRCCTL}$ (@ $f_{sys} = f_{MAX}$ )	25° C		40	—	—
	6, 7, 8, 9	150° C		50	500	—

<sup>1</sup> On power up, assert  $\overline{RESET}$  before  $V_{POR15}$ ,  $V_{POR33}$ , and  $V_{POR5}$  negate (internal POR).  $\overline{RESET}$  must remain asserted until the power supplies are within the operating conditions as specified in Table 9 DC Electrical Specifications. On power down, assert  $\overline{RESET}$  before any power supplies fall outside the operating conditions and until the internal POR asserts.

<sup>2</sup>  $V_{IL,S}$  (Table 9, Spec15) is guaranteed to scale with  $V_{DDEH6}$  down to  $V_{POR5}$ .

<sup>3</sup> Supply full operating current for the 1.5 V supply when the 3.3 V supply reaches this range.

<sup>4</sup> It is possible to reach the current limit during ramp up—do not treat this event as short circuit current.

<sup>5</sup> At peak current for device.

<sup>6</sup> Requires compliance with Freescale's recommended board requirements and transistor recommendations. Board signal traces/routing from the  $V_{RCCTL}$  package signal to the base of the external pass transistor and between the emitter of the pass transistor to the  $V_{DD}$  package signals must have a maximum of 100 nH inductance and minimal resistance (less than 1  $\Omega$ ).  $V_{RCCTL}$  must have a nominal 1  $\mu$ F phase compensation capacitor to ground.  $V_{DD}$  must have a 20  $\mu$ F (nominal) bulk capacitor (greater than 4  $\mu$ F over all conditions, including lifetime). Place high-frequency bypass capacitors consisting of eight 0.01  $\mu$ F, two 0.1  $\mu$ F, and one 1  $\mu$ F capacitors around the package on the  $V_{DD}$  supply signals.

<sup>7</sup>  $I_{VRCCTL}$  is measured at the following conditions:  $V_{DD} = 1.35$  V,  $V_{RC33} = 3.1$  V,  $V_{VRCCTL} = 2.2$  V.

<sup>8</sup> Refer to Table 1 for the maximum operating frequency.

<sup>9</sup> Values are based on  $I_{DD}$  from high-use applications as explained in the  $I_{DD}$  Electrical Specification.

<sup>10</sup> BETA represents the worst-case external transistor. It is measured on a per-part basis and calculated as  $(I_{DD} \div I_{VRCCTL})$ .

### 3.7 Power-Up/Down Sequencing

Power sequencing between the 1.5 V power supply and  $V_{DDSYN}$  or the  $\overline{RESET}$  power supplies is required if using an external 1.5 V power supply with  $V_{RC33}$  tied to ground (GND). To avoid power-sequencing,  $V_{RC33}$  must be powered up within the specified operating range, even if the on-chip voltage regulator controller is not used. Refer to Section 3.7.2, “Power-Up Sequence (VRC33 Grounded),” and Section 3.7.3, “Power-Down Sequence (VRC33 Grounded).”

Power sequencing requires that  $V_{DD33}$  must reach a certain voltage where the values are read as ones before the POR signal negates. Refer to Section 3.7.1, “Input Value of Pins During POR Dependent on VDD33.”

Although power sequencing is not required between  $V_{RC33}$  and  $V_{DDSYN}$  during power up,  $V_{RC33}$  must not lead  $V_{DDSYN}$  by more than 600 mV or lag by more than 100 mV for the  $V_{RC}$  stage turn-on to operate within specification. Higher spikes in the emitter current of the pass transistor occur if  $V_{RC33}$  leads or lags  $V_{DDSYN}$  by more than these amounts. The value of that higher spike in current depends on the board power supply circuitry and the amount of board level capacitance.

Furthermore, when all of the PORs negate, the system clock starts to toggle, adding another large increase of the current consumed by  $V_{RC33}$ . If  $V_{RC33}$  lags  $V_{DDSYN}$  by more than 100 mV, the increase in current consumed can drop  $V_{DD}$  low enough to assert the 1.5 V POR again. Oscillations are possible when the 1.5 V POR asserts and stops the system clock, causing the voltage on  $V_{DD}$  to rise until the 1.5 V POR negates again. All oscillations stop when  $V_{RC33}$  is powered sufficiently.

When powering down,  $V_{RC33}$  and  $V_{DDSYN}$  have no delta requirement to each other, because the bypass capacitors internal and external to the device are already charged. When not powering up or down, no delta between  $V_{RC33}$  and  $V_{DDSYN}$  is required for the  $V_{RC}$  to operate within specification.

There are no power up/down sequencing requirements to prevent issues such as latch-up, excessive current spikes, and so on. Therefore, the state of the I/O pins during power up and power down varies depending on which supplies are powered.

Table 7 gives the pin state for the sequence cases for all pins with pad type pad\_fc (fast type).

**Table 7. Pin Status for Fast Pads During the Power Sequence**

$V_{DDE}$	$V_{DD33}$	$V_{DD}$	POR	Pin Status for Fast Pad Output Driver pad_fc (fast)
Low	—	—	Asserted	Low
$V_{DDE}$	Low	Low	Asserted	High
$V_{DDE}$	Low	$V_{DD}$	Asserted	High
$V_{DDE}$	$V_{DD33}$	Low	Asserted	High impedance (Hi-Z)
$V_{DDE}$	$V_{DD33}$	$V_{DD}$	Asserted	Hi-Z
$V_{DDE}$	$V_{DD33}$	$V_{DD}$	Negated	Functional

Table 8 gives the pin state for the sequence cases for all pins with pad type pad\_mh (medium type) and pad\_sh (slow type).

**Table 8. Pin Status for Medium and Slow Pads During the Power Sequence**

$V_{DDEH}$	$V_{DD}$	POR	Pin Status for Medium and Slow Pad Output Driver pad_mh (medium) pad_sh (slow)
Low	—	Asserted	Low
$V_{DDEH}$	Low	Asserted	High impedance (Hi-Z)
$V_{DDEH}$	$V_{DD}$	Asserted	Hi-Z
$V_{DDEH}$	$V_{DD}$	Negated	Functional

The values in Table 7 and Table 8 do not include the effect of the weak-pull devices on the output pins during power up.

Before exiting the internal POR state, the pins go to a high-impedance state until POR negates. When the internal POR negates, the functional state of the signal during reset applies and the weak-pull devices (up or down) are enabled as defined in the device reference manual. If  $V_{DD}$  is too low to correctly propagate the logic signals, the weak-pull devices can pull the signals to  $V_{DDE}$  and  $V_{DDEH}$ .

To avoid this condition, minimize the ramp time of the  $V_{DD}$  supply to a time period less than the time required to enable the external circuitry connected to the device outputs.

### 3.7.1 Input Value of Pins During POR Dependent on $V_{DD33}$

When powering up the device,  $V_{DD33}$  must not lag the latest  $V_{DDSYN}$  or  $\overline{RESET}$  power pin ( $V_{DDEH6}$ ) by more than the  $V_{DD33}$  lag specification listed in Table 6, spec 8. This avoids accidentally selecting the bypass clock mode because the internal versions of PLLCFG[0:1] and  $\overline{RSTCFG}$  are not powered and therefore cannot read the default state when POR negates.  $V_{DD33}$  can lag  $V_{DDSYN}$  or the  $\overline{RESET}$  power pin ( $V_{DDEH6}$ ), but cannot lag both by more than the  $V_{DD33}$  lag specification. This  $V_{DD33}$  lag specification applies during power up only.  $V_{DD33}$  has no lead or lag requirements when powering down.

### 3.7.2 Power-Up Sequence ( $V_{RC33}$ Grounded)

The 1.5 V  $V_{DD}$  power supply must rise to 1.35 V before the 3.3 V  $V_{DDSYN}$  power supply and the  $\overline{RESET}$  power supply rises above 2.0 V. This ensures that digital logic in the PLL for the 1.5 V power supply does not begin to operate below the specified operation range lower limit of 1.35 V. Because the internal 1.5 V POR is disabled, the internal 3.3 V POR or the  $\overline{RESET}$  power POR must hold the device in reset. Since they can negate as low as 2.0 V,  $V_{DD}$  must be within specification before the 3.3 V POR and the  $\overline{RESET}$  POR negate.

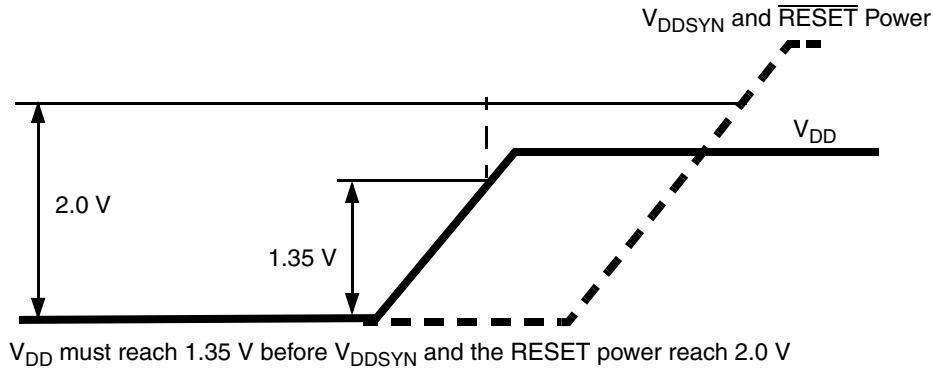

Figure 2. Power-Up Sequence ( $V_{RC33}$  Grounded)

### 3.7.3 Power-Down Sequence ( $V_{RC33}$ Grounded)

The only requirement for the power-down sequence with  $V_{RC33}$  grounded is if  $V_{DD}$  decreases to less than its operating range,  $V_{DDSYN}$  or the  $\overline{RESET}$  power must decrease to less than 2.0 V before the  $V_{DD}$  power increases to its operating range. This ensures that the digital 1.5 V logic, which is reset only by an ORed POR and can cause the 1.5 V supply to decrease less than its specification value, resets correctly.

### 3.8 DC Electrical Specifications

Table 9. DC Electrical Specifications ( $T_A = T_L - T_H$ )

Spec	Characteristic	Symbol	Min	Max.	Unit
1	Core supply voltage (average DC RMS voltage)	$V_{DD}$	1.35	1.65	V
2	Input/output supply voltage (fast input/output) <sup>1</sup>	$V_{DDE}$	1.62	3.6	V
3	Input/output supply voltage (slow and medium input/output)	$V_{DDEH}$	3.0	5.25	V
4	3.3 V input/output buffer voltage	$V_{DD33}$	3.0	3.6	V
5	Voltage regulator control input voltage	$V_{RC33}$	3.0	3.6	V
6	Analog supply voltage <sup>2</sup>	$V_{DDA}$	4.5	5.25	V
8	Flash programming voltage <sup>3</sup>	$V_{PP}$	4.5	5.25	V
9	Flash read voltage	$V_{FLASH}$	3.0	3.6	V
10	SRAM standby voltage <sup>4</sup>	$V_{STBY}$	0.8	1.2	V
11	Clock synthesizer operating voltage	$V_{DDSYN}$	3.0	3.6	V
12	Fast I/O input high voltage	$V_{IH\_F}$	$0.65 \times V_{DDE}$	$V_{DDE} + 0.3$	V
13	Fast I/O input low voltage	$V_{IL\_F}$	$V_{SS} - 0.3$	$0.35 \times V_{DDE}$	V
14	Medium and slow I/O input high voltage	$V_{IH\_S}$	$0.65 \times V_{DDEH}$	$V_{DDEH} + 0.3$	V
15	Medium and slow I/O input low voltage	$V_{IL\_S}$	$V_{SS} - 0.3$	$0.35 \times V_{DDEH}$	V
16	Fast input hysteresis	$V_{HYS\_F}$	$0.1 \times V_{DDE}$		V
17	Medium and slow I/O input hysteresis	$V_{HYS\_S}$	$0.1 \times V_{DDEH}$		V
18	Analog input voltage	$V_{INDC}$	$V_{SSA} - 0.3$	$V_{DDA} + 0.3$	V
19	Fast output high voltage ( $I_{OH\_F} = -2.0$ mA )	$V_{OH\_F}$	$0.8 \times V_{DDE}$	—	V
20	Slow and medium output high voltage $I_{OH\_S} = -2.0$ mA $I_{OH\_S} = -1.0$ mA	$V_{OH\_S}$	$0.80 \times V_{DDEH}$ $0.85 \times V_{DDEH}$	—	V
21	Fast output low voltage ( $I_{OL\_F} = 2.0$ mA )	$V_{OL\_F}$	—	$0.2 \times V_{DDE}$	V
22	Slow and medium output low voltage $I_{OL\_S} = 2.0$ mA $I_{OL\_S} = 1.0$ mA	$V_{OL\_S}$	—	$0.20 \times V_{DDEH}$ $0.15 \times V_{DDEH}$	V
23	Load capacitance (fast I/O) <sup>5</sup> DSC (SIU_PCR[8:9]) = 0b00 = 0b01 = 0b10 = 0b11	$C_L$	— — — —	10 20 30 50	pF pF pF pF
24	Input capacitance (digital pins)	$C_{IN}$	—	7	pF
25	Input capacitance (analog pins)	$C_{IN\_A}$	—	10	pF
26	Input capacitance: (Shared digital and analog pins AN[12]_MA[0]_SDS, AN[13]_MA[1]_SDO, AN[14]_MA[2]_SDI, and AN[15]_FCK)	$C_{IN\_M}$	—	12	pF

## Electrical Characteristics

**Table 9. DC Electrical Specifications ( $T_A = T_L - T_H$ ) (continued)**

Spec	Characteristic	Symbol	Min	Max.	Unit
27a	Operating current 1.5 V supplies @ 82 MHz: <sup>6, 7</sup>				
	$V_{DD}$ (including $V_{DDF}$ max current) @ 1.65 V high use <sup>8, 9, 10, 11, 12</sup>	$I_{DD}$	—	250	mA
	$V_{DD}$ (including $V_{DDF}$ max current) @ 1.35 V high use <sup>8, 9, 10, 11, 12</sup>	$I_{DD}$	—	180	mA
27b	Operating current 1.5 V supplies @ 68 MHz: <sup>13, 14</sup>				
	$V_{DD}$ (including $V_{DDF}$ max current) @ 1.65 V high use <sup>15, 16, 17</sup>	$I_{DD}$	—	210	mA
	$V_{DD}$ (including $V_{DDF}$ max current) @ 1.35 V high use <sup>15, 16, 17</sup>	$I_{DD}$	—	160	mA
27c	Operating current 1.5 V supplies @ 42 MHz: <sup>13, 14</sup>				
	$V_{DD}$ (including $V_{DDF}$ max current) @ 1.65 V high use <sup>15, 16, 17</sup>	$I_{DD}$	—	130	mA
	$V_{DD}$ (including $V_{DDF}$ max current) @ 1.35 V high use <sup>15, 16, 17</sup>	$I_{DD}$	—	110	mA
27d	Refer to <a href="#">Figure 3</a> for an interpolation of this data. <sup>18</sup>				
	$I_{DD\_STBY}$ @ 25° C				
	$V_{STBY}$ @ 0.8 V	$I_{DD\_STBY}$	—	20	μA
	$V_{STBY}$ @ 1.0 V	$I_{DD\_STBY}$	—	30	μA
	$V_{STBY}$ @ 1.2 V	$I_{DD\_STBY}$	—	50	μA
	$I_{DD\_STBY}$ @ 60° C				
	$V_{STBY}$ @ 0.8 V	$I_{DD\_STBY}$	—	70	μA
	$V_{STBY}$ @ 1.0 V	$I_{DD\_STBY}$	—	100	μA
	$V_{STBY}$ @ 1.2 V	$I_{DD\_STBY}$	—	200	μA
	$I_{DD\_STBY}$ @ 150° C ( $T_j$ )				
	$V_{STBY}$ @ 0.8 V	$I_{DD\_STBY}$	—	1200	μA
	$V_{STBY}$ @ 1.0 V	$I_{DD\_STBY}$	—	1500	μA
$V_{STBY}$ @ 1.2 V	$I_{DD\_STBY}$	—	2000	μA	
28	Operating current 3.3 V supplies @ $f_{MAX}$ MHz				
	$V_{DD33}$ <sup>19</sup>	$I_{DD\_33}$	—	2 + (values derived from procedure of footnote <sup>19</sup> )	mA
	$V_{FLASH}$	$I_{VFLASH}$	—	10	mA
	$V_{DDSYN}$	$I_{DDSYN}$	—	15	mA
29	Operating current 5.0 V supplies (12 MHz ADCLK):				
	$V_{DDA}$ ( $V_{DDA0} + V_{DDA1}$ )	$I_{DD\_A}$	—	20.0	mA
	Analog reference supply current ( $V_{RH}$ , $V_{RL}$ )	$I_{REF}$	—	1.0	mA
	$V_{PP}$	$I_{PP}$	—	25.0	mA
30	Operating current $V_{DDE}$ supplies: <sup>20</sup>				
	$V_{DDEH1}$	$I_{DD1}$	—	Refer to Footnote <sup>20</sup>	mA
	$V_{DDE2}$	$I_{DD2}$	—		mA
	$V_{DDE3}$	$I_{DD3}$	—		mA
	$V_{DDEH4}$	$I_{DD4}$	—		mA
	$V_{DDE5}$	$I_{DD5}$	—		mA
	$V_{DDEH6}$	$I_{DD6}$	—		mA
	$V_{DDE7}$	$I_{DD7}$	—		mA
	$V_{DDEH8}$	$I_{DD8}$	—		mA
	$V_{DDEH9}$	$I_{DD9}$	—		mA

Table 9. DC Electrical Specifications ( $T_A = T_L - T_H$ ) (continued)

Spec	Characteristic	Symbol	Min	Max.	Unit
31	Fast I/O weak pullup current <sup>21</sup> 1.62–1.98 V 2.25–2.75 V 3.00–3.60 V	$I_{ACT\_F}$	10	110	$\mu A$
	20		130	$\mu A$	
	Fast I/O weak pulldown current <sup>21</sup> 1.62–1.98 V 2.25–2.75 V 3.00–3.60 V		20	170	$\mu A$
32	Slow and medium I/O weak pullup/down current <sup>21</sup> 3.0–3.6 V 4.5–5.5 V	$I_{ACT\_S}$	10 20	150 170	$\mu A$ $\mu A$
33	I/O input leakage current <sup>22</sup>	$I_{INACT\_D}$	-2.5	2.5	$\mu A$
34	DC injection current (per pin)	$I_{IC}$	-2.0	2.0	mA
35	Analog input current, channel off <sup>23</sup>	$I_{INACT\_A}$	-150	150	nA
35a	Analog input current, shared analog / digital pins (AN[12], AN[13], AN[14], AN[15])	$I_{INACT\_AD}$	-2.5	2.5	$\mu A$
36	$V_{SS}$ to $V_{SSA}$ differential voltage <sup>24</sup>	$V_{SS} - V_{SSA}$	-100	100	mV
37	Analog reference low voltage	$V_{RL}$	$V_{SSA} - 0.1$	$V_{SSA} + 0.1$	V
38	$V_{RL}$ differential voltage	$V_{RL} - V_{SSA}$	-100	100	mV
39	Analog reference high voltage	$V_{RH}$	$V_{DDA} - 0.1$	$V_{DDA} + 0.1$	V
40	$V_{REF}$ differential voltage	$V_{RH} - V_{RL}$	4.5	5.25	V
41	$V_{SSSYN}$ to $V_{SS}$ differential voltage	$V_{SSSYN} - V_{SS}$	-50	50	mV
42	$V_{RCVSS}$ to $V_{SS}$ differential voltage	$V_{RCVSS} - V_{SS}$	-50	50	mV
43	$V_{DDF}$ to $V_{DD}$ differential voltage	$V_{DDF} - V_{DD}$	-100	100	mV
43a	$V_{RC33}$ to $V_{DDSYN}$ differential voltage	$V_{RC33} - V_{DDSYN}$	-0.1	0.1 <sup>25</sup>	V
44	Analog input differential signal range (with common mode 2.5 V)	$V_{IDIFF}$	-2.5	2.5	V
45	Operating temperature range, ambient (packaged)	$T_A = (T_L \text{ to } T_H)$	$T_L$	$T_H$	$^{\circ}C$
46	Slew rate on power-supply pins	—	—	50	V/ms

<sup>1</sup>  $V_{DDE2}$  and  $V_{DDE3}$  are limited to 2.25–3.6 V only if EBTS = 0;  $V_{DDE2}$  and  $V_{DDE3}$  have a range of 1.6–3.6 V if EBTS = 1.

<sup>2</sup>  $|V_{DDA0} - V_{DDA1}|$  must be  $< 0.1$  V.

<sup>3</sup>  $V_{PP}$  can drop to 3.0 V during read operations.

<sup>4</sup> If standby operation is not required, connect  $V_{STBY}$  to ground.

<sup>5</sup> Applies to CLKOUT, external bus pins, and Nexus pins.

<sup>6</sup> Maximum average RMS DC current.

<sup>7</sup> Figure 3 shows an illustration of the  $I_{DD\_STBY}$  values interpolated for these temperature values.

<sup>8</sup> Average current measured on Automotive benchmark.

<sup>9</sup> Peak currents can be higher on specialized code.

<sup>10</sup> High use current measured while running optimized SPE assembly code with all channels of the eTPU running autonomously, plus the eDMA transferring data continuously from SRAM to SRAM.

## Electrical Characteristics

- <sup>11</sup> Power requirements for the  $V_{DD33}$  supply depend on the frequency of operation, load of all I/O pins, and the voltages on the I/O segments. Refer to [Table 11](#) for values to calculate power dissipation for specific operation.
- <sup>12</sup> Power requirements for each I/O segment are dependent on the frequency of operation and load of the I/O pins on a particular I/O segment, and the voltage of the I/O segment. Refer to [Table 10](#) for values to calculate power dissipation for specific operation. The total power consumption of an I/O segment is the sum of the individual power consumptions for each pin on the segment.
- <sup>13</sup> Maximum average RMS DC current.
- <sup>14</sup> [Figure 3](#) shows an illustration of the  $I_{DD\_STBY}$  values interpolated for these temperature values.
- <sup>15</sup> Average current measured on automotive benchmark.
- <sup>16</sup> Peak currents can be higher on specialized code.
- <sup>17</sup> High use current measured while running optimized SPE assembly code with all channels of the eTPU running autonomously, plus the eDMA transferring data continuously from SRAM to SRAM.
- <sup>18</sup> [Figure 3](#) shows an illustration of the  $I_{DD\_STBY}$  values interpolated for these temperature values.
- <sup>19</sup> Power requirements for the  $V_{DD33}$  supply depend on the frequency of operation, load of all I/O pins, and the voltages on the I/O segments. Refer to [Table 11](#) for values to calculate the power dissipation for a specific operation.
- <sup>20</sup> Power requirements for each I/O segment are dependent on the frequency of operation and load of the I/O pins on a particular I/O segment, and the voltage of the I/O segment. Refer to [Table 10](#) for values to calculate power dissipation for specific operation. The total power consumption of an I/O segment is the sum of the individual power consumptions for each pin on the segment.
- <sup>21</sup> Absolute value of current, measured at  $V_{IL}$  and  $V_{IH}$ .
- <sup>22</sup> Weak pullup/down inactive. Measured at  $V_{DDE} = 3.6$  V and  $V_{DDEH} = 5.25$  V. Applies to pad types: pad\_fc, pad\_sh, and pad\_mh.
- <sup>23</sup> Maximum leakage occurs at maximum operating temperature. Leakage current decreases by approximately one-half for each 8 °C to 12 °C, in the ambient temperature range of 50 °C to 125 °C. Applies to pad types: pad\_a and pad\_ae.
- <sup>24</sup>  $V_{SSA}$  refers to both  $V_{SSA0}$  and  $V_{SSA1}$ .  $|V_{SSA0} - V_{SSA1}|$  must be  $< 0.1$  V.
- <sup>25</sup> Up to 0.6 V during power up and power down.



Figure 3 shows an approximate interpolation of the  $I_{STBY}$  worst-case specification to estimate values at different voltages and temperatures. The vertical lines shown at 25 °C, 60 °C, and 150 °C in Figure 3 are the  $I_{DD\_STBY}$  specifications (27d) listed in Table 9.

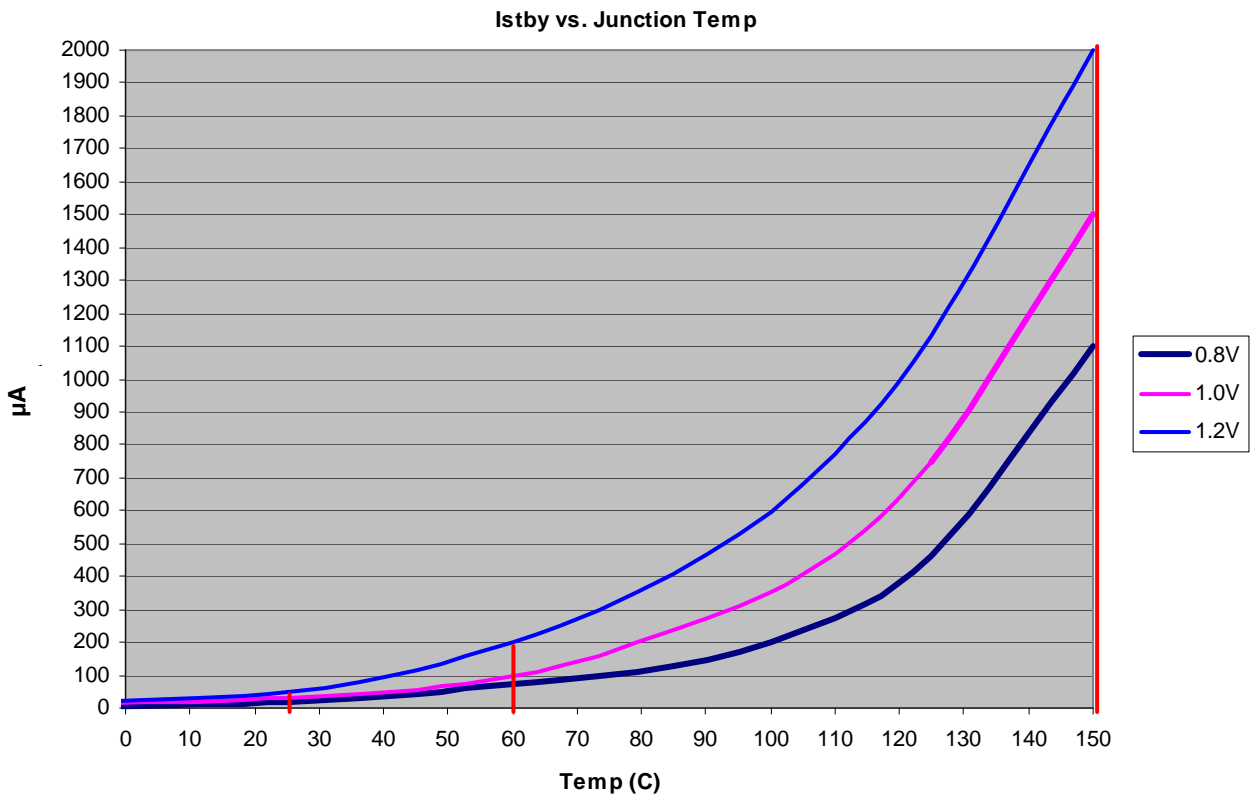

Figure 3.  $I_{STBY}$  Worst-case Specifications

### 3.8.1 I/O Pad Current Specifications

The power consumption of an I/O segment depends on the usage of the pins on a particular segment. The power consumption is the sum of all output pin currents for a segment. The output pin current can be calculated from Table 10 based on the voltage, frequency, and load on the pin. Use linear scaling to calculate pin currents for voltage, frequency, and load parameters that fall outside the values given in Table 10.

Table 10. I/O Pad Average DC Current ( $T_A = T_L - T_H$ )<sup>1</sup>

Spec	Pad Type	Symbol	Frequency (MHz)	Load <sup>2</sup> (pF)	Voltage (V)	Drive Select / Slew Rate Control Setting	Current (mA)
1	Slow	I <sub>DRV_SH</sub>	25	50	5.25	11	8.0
2			10	50	5.25	01	3.2
3			2	50	5.25	00	0.7
4			2	200	5.25	00	2.4
5	Medium	I <sub>DRV_MH</sub>	50	50	5.25	11	17.3
6			20	50	5.25	01	6.5
7			3.33	50	5.25	00	1.1
8			3.33	200	5.25	00	3.9
9	Fast	I <sub>DRV_FC</sub>	66	10	3.6	00	2.8
10			66	20	3.6	01	5.2
11			66	30	3.6	10	8.5
12			66	50	3.6	11	11.0
13			66	10	1.98	00	1.6
14			66	20	1.98	01	2.9
15			66	30	1.98	10	4.2
16			66	50	1.98	11	6.7
17			56	10	3.6	00	2.4
18			56	20	3.6	01	4.4
19			56	30	3.6	10	7.2
20			56	50	3.6	11	9.3
21			56	10	1.98	00	1.3
22			56	20	1.98	01	2.5
23			56	30	1.98	10	3.5
24			56	50	1.98	11	5.7
25			40	10	3.6	00	1.7
26			40	20	3.6	01	3.1
27			40	30	3.6	10	5.1
28			40	50	3.6	11	6.6
29			40	10	1.98	00	1.0
30			40	20	1.98	01	1.8
31			40	30	1.98	10	2.5
32			40	50	1.98	11	4.0

<sup>1</sup> These values are estimates from simulation and are not tested. Currents apply to output pins only.

<sup>2</sup> All loads are lumped.

### 3.8.2 I/O Pad $V_{DD33}$ Current Specifications

The power consumption of the  $V_{DD33}$  supply depends on the usage of the pins on all I/O segments. The power consumption is the sum of all input and output pin  $V_{DD33}$  currents for all I/O segments. The output pin  $V_{DD33}$  current can be calculated from Table 11 based on the voltage, frequency, and load on all fast (pad\_fc) pins. The input pin  $V_{DD33}$  current can be calculated from Table 11 based on the voltage, frequency, and load on all pad\_sh and pad\_mh pins. Use linear scaling to calculate pin currents for voltage, frequency, and load parameters that fall outside the values given in Table 11.

Table 11.  $V_{DD33}$  Pad Average DC Current ( $T_A = T_L - T_H$ )<sup>1</sup>

Spec	Pad Type	Symbol	Frequency (MHz)	Load <sup>2</sup> (pF)	$V_{DD33}$ (V)	$V_{DDE}$ (V)	Drive Select	Current (mA)
<b>Inputs</b>								
1	Slow	$I_{33\_SH}$	66	0.5	3.6	5.5	NA	0.003
2	Medium	$I_{33\_MH}$	66	0.5	3.6	5.5	NA	0.003
<b>Outputs</b>								
3	Fast	$I_{33\_FC}$	66	10	3.6	3.6	00	0.35
4			66	20	3.6	3.6	01	0.53
5			66	30	3.6	3.6	10	0.62
6			66	50	3.6	3.6	11	0.79
7			66	10	3.6	1.98	00	0.35
8			66	20	3.6	1.98	01	0.44
9			66	30	3.6	1.98	10	0.53
10			66	50	3.6	1.98	11	0.70
11			56	10	3.6	3.6	00	0.30
12			56	20	3.6	3.6	01	0.45
13			56	30	3.6	3.6	10	0.52
14			56	50	3.6	3.6	11	0.67
15			56	10	3.6	1.98	00	0.30
16			56	20	3.6	1.98	01	0.37
17			56	30	3.6	1.98	10	0.45
18			56	50	3.6	1.98	11	0.60
19			40	10	3.6	3.6	00	0.21
20			40	20	3.6	3.6	01	0.31
21			40	30	3.6	3.6	10	0.37
22			40	50	3.6	3.6	11	0.48
23			40	10	3.6	1.98	00	0.21
24			40	20	3.6	1.98	01	0.27
25			40	30	3.6	1.98	10	0.32
26			40	50	3.6	1.98	11	0.42

<sup>1</sup> These values are estimated from simulation and not tested. Currents apply to output pins for the fast pads only and to input pins for the slow and medium pads only.

<sup>2</sup> All loads are lumped.

### 3.9 Oscillator and FMPLL Electrical Characteristics

**Table 12. FMPLL Electrical Specifications**  
 ( $V_{DDSYN} = 3.0\text{--}3.6\text{ V}$ ;  $V_{SS} = V_{SSSYN} = 0.0\text{ V}$ ;  $T_A = T_L$  to  $T_H$ )

Spec	Characteristic	Symbol	Minimum	Maximum	Unit
1	PLL reference frequency range: <sup>1</sup> Crystal reference External reference Dual controller (1:1 mode)	$f_{ref\_crystal}$ $f_{ref\_ext}$ $f_{ref\_1:1}$	8 8 24	20 20 $f_{sys} \div 2$	MHz
2	System frequency <sup>2</sup>	$f_{sys}$	$f_{ICO(MIN)} \div 2^{RFD}$	$f_{MAX}$ <sup>3</sup>	MHz
3	System clock period	$t_{CYC}$	—	$1 \div f_{sys}$	ns
4	Loss of reference frequency <sup>4</sup>	$f_{LOR}$	100	1000	kHz
5	Self-clocked mode (SCM) frequency <sup>5</sup>	$f_{SCM}$	7.4	17.5	MHz
6	EXTAL input high voltage crystal mode <sup>6</sup> All other modes [dual controller (1:1), bypass, external reference]	$V_{IHEXT}$	$V_{XTAL} + 0.4\text{ V}$	—	V
		$V_{IHEXT}$	$(V_{DDE5} \div 2) + 0.4\text{ V}$	—	V
7	EXTAL input low voltage crystal mode <sup>7</sup> All other modes [dual controller (1:1), bypass, external reference]	$V_{ILEXT}$	—	$V_{XTAL} - 0.4\text{ V}$	V
		$V_{ILEXT}$	—	$(V_{DDE5} \div 2) - 0.4\text{ V}$	V
8	XTAL current <sup>8</sup>	$I_{XTAL}$	0.8	3	mA
9	Total on-chip stray capacitance on XTAL	$C_{S\_XTAL}$	—	1.5	pF
10	Total on-chip stray capacitance on EXTAL	$C_{S\_EXTAL}$	—	1.5	pF
11	Crystal manufacturer's recommended capacitive load	$C_L$	Refer to crystal specification	Refer to crystal specification	pF
12	Discrete load capacitance to connect to EXTAL	$C_{L\_EXTAL}$	—	$(2 \times C_L) - C_{S\_EXTAL} - C_{PCB\_EXTAL}$ <sup>9</sup>	pF
13	Discrete load capacitance to connect to XTAL	$C_{L\_XTAL}$	—	$(2 \times C_L) - C_{S\_XTAL} - C_{PCB\_XTAL}$ <sup>9</sup>	pF
14	PLL lock time <sup>10</sup>	$t_{pll}$	—	750	$\mu\text{s}$
15	Dual controller (1:1) clock skew (between CLKOUT and EXTAL) <sup>11, 12</sup>	$t_{skew}$	-2	2	ns
16	Duty cycle of reference	$t_{DC}$	40	60	%
17	Frequency unLOCK range	$f_{UL}$	-4.0	4.0	% $f_{sys}$
18	Frequency LOCK range	$f_{LCK}$	-2.0	2.0	% $f_{sys}$

Table 12. FMPLL Electrical Specifications (continued)

 $(V_{DDSYN} = 3.0\text{--}3.6\text{ V}; V_{SS} = V_{SSSYN} = 0.0\text{ V}; T_A = T_L \text{ to } T_H)$ 

Spec	Characteristic	Symbol	Minimum	Maximum	Unit
19	CLKOUT period jitter, measured at $f_{SYS}$ max: <sup>13, 14</sup> Peak-to-peak jitter (clock edge to clock edge) Long term jitter (averaged over a 2 ms interval)	$C_{JITTER}$	— —	5.0 0.01	% $f_{CLKOUT}$
20	Frequency modulation range limit <sup>15</sup> (do not exceed $f_{SYS}$ maximum)	$C_{MOD}$	0.8	2.4	% $f_{SYS}$
21	ICO frequency $f_{ICO} = [f_{ref\_crystal} \times (MFD + 4)] \div (PREDIV + 1)$ <sup>16</sup> $f_{ICO} = [f_{ref\_ext} \times (MFD + 4)] \div (PREDIV + 1)$	$f_{ICO}$	48	80 <sup>17</sup>	MHz
22	Predivider output frequency (to PLL)	$f_{PREDIV}$	4	20 <sup>18</sup>	MHz

<sup>1</sup> Nominal crystal and external reference values are worst-case not more than 1%. The device operates correctly if the frequency remains within  $\pm 5\%$  of the specification limit. This tolerance range allows for a slight frequency drift of the crystals over time. The designer must thoroughly understand the drift margin of the source clock.

<sup>2</sup> All internal registers retain data at 0 Hz.

<sup>3</sup> Up to the maximum frequency rating of the device (refer to Table 1).

<sup>4</sup> Loss of reference frequency is defined as the reference frequency detected internally, which transitions the PLL into self-clocked mode.

<sup>5</sup> The PLL operates at self-clocked mode (SCM) frequency when the reference frequency falls below  $f_{LOR}$ . SCM frequency is measured on the CLKOUT ball with the divider set to divide-by-two of the system clock.  
NOTE: In SCM, the MFD and PREDIV have no effect and the RFD is bypassed.

<sup>6</sup> Use the EXTAL input high voltage parameter when using the FlexCAN oscillator in crystal mode (no quartz crystals or resonators).  $(V_{extal} - V_{xtal})$  must be  $\geq 400$  mV for the oscillator's comparator to produce the output clock.

<sup>7</sup> Use the EXTAL input low voltage parameter when using the FlexCAN oscillator in crystal mode (no quartz crystals or resonators).  $(V_{xtal} - V_{extal})$  must be  $\geq 400$  mV for the oscillator's comparator to produce the output clock.

<sup>8</sup>  $I_{xtal}$  is the oscillator bias current out of the XTAL pin with both EXTAL and XTAL pins grounded.

<sup>9</sup>  $C_{PCB\_EXTAL}$  and  $C_{PCB\_XTAL}$  are the measured PCB stray capacitances on EXTAL and XTAL, respectively.

<sup>10</sup> This specification applies to the period required for the PLL to relock after changing the MFD frequency control bits in the synthesizer control register (SYNCR). From power up with crystal oscillator reference, the lock time also includes the crystal startup time.

<sup>11</sup> PLL is operating in 1:1 PLL mode.

<sup>12</sup>  $V_{DDE} = 3.0\text{--}3.6\text{ V}$ .

<sup>13</sup> Jitter is the average deviation from the programmed frequency measured over the specified interval at maximum  $f_{SYS}$ . Measurements are made with the device powered by filtered supplies and clocked by a stable external clock signal. Noise injected into the PLL circuitry via  $V_{DDSYN}$  and  $V_{SSSYN}$  and variation in crystal oscillator frequency increase the jitter percentage for a given interval. CLKOUT divider is set to divide-by-two.

<sup>14</sup> Values are with frequency modulation disabled. If frequency modulation is enabled, jitter is the sum of (jitter + Cmod).

<sup>15</sup> Modulation depth selected must not result in  $f_{SYS}$  value greater than the  $f_{SYS}$  maximum specified value.

<sup>16</sup>  $f_{SYS} = f_{ICO} \div (2^{RFD})$

<sup>17</sup> The ICO frequency can be higher than the maximum allowable system frequency. For this case, set the FMPLL synthesizer control register reduced frequency divider (FMPLL\_SYNCR[RFD]) to divide-by-two (RFD = 0b001). Therefore, for a 40 MHz maximum device (system frequency), program the FMPLL to generate 80 MHz at the ICO output and then divide-by-two the RFD to provide the 40 MHz clock.

<sup>18</sup> Maximum value for dual controller (1:1) mode is  $(f_{MAX} \div 2)$  with the predivider set to 1 (FMPLL\_SYNCR[PREDIV] = 0b001).

### 3.10 eQADC Electrical Characteristics

Table 13. eQADC Conversion Specifications ( $T_A = T_L$  to  $T_H$ )

Spec	Characteristic	Symbol	Minimum	Maximum	Unit
1	ADC clock (ADCLK) frequency <sup>1</sup>	$F_{ADCLK}$	1	12	MHz
2	Conversion cycles Differential Single ended	CC	13 + 2 (15) 14 + 2 (16)	13 + 128 (141) 14 + 128 (142)	ADCLK cycles
3	Stop mode recovery time <sup>2</sup>	$T_{SR}$	10	—	$\mu$ s
4	Resolution <sup>3</sup>	—	1.25	—	mV
5	INL: 6 MHz ADC clock	INL6	-4	4	Counts <sup>3</sup>
6	INL: 12 MHz ADC clock	INL12	-8	8	Counts
7	DNL: 6 MHz ADC clock	DNL6	-3 <sup>4</sup>	3 <sup>4</sup>	Counts
8	DNL: 12 MHz ADC clock	DNL12	-6 <sup>4</sup>	6 <sup>4</sup>	Counts
9	Offset error with calibration	OFFWC	-4 <sup>5</sup>	4 <sup>5</sup>	Counts
10	Full-scale gain error with calibration	GAINWC	-8 <sup>6</sup>	8 <sup>6</sup>	Counts
11	Disruptive input injection current <sup>7, 8, 9, 10</sup>	$I_{INJ}$	-1	1	mA
12	Incremental error due to injection current. All channels are $10\text{ k}\Omega < R_s < 100\text{ k}\Omega$ Channel under test has $R_s = 10\text{ k}\Omega$ , $I_{INJ} = I_{INJMAX}, I_{INJMIN}$	$E_{INJ}$	-4	4	Counts
13	Total unadjusted error (TUE) for single ended conversions with calibration <sup>11, 12, 13, 14, 15</sup>	TUE	-4	4	Counts

<sup>1</sup> Conversion characteristics vary with  $F_{ADCLK}$  rate. Reduced conversion accuracy occurs at maximum  $F_{ADCLK}$  rate. The maximum value is based on 800 KS/s and the minimum value is based on 20 MHz oscillator clock frequency divided by a maximum 16 factor.

<sup>2</sup> Stop mode recovery time begins when the ADC control register enable bits are set until the ADC is ready to perform conversions.

<sup>3</sup> At  $V_{RH} - V_{RL} = 5.12\text{ V}$ , one least significant bit (LSB) = 1.25, mV = one count.

<sup>4</sup> Guaranteed 10-bit mono tonicity.

<sup>5</sup> The absolute value of the offset error without calibration  $\leq 100$  counts.

<sup>6</sup> The absolute value of the full scale gain error without calibration  $\leq 120$  counts.

<sup>7</sup> Below disruptive current conditions, the channel being stressed has conversion values of: 0x3FF for analog inputs greater than  $V_{RH}$ , and 0x000 for values less than  $V_{RL}$ . This assumes that  $V_{RH} \leq V_{DDA}$  and  $V_{RL} \geq V_{SSA}$  due to the presence of the sample amplifier. Other channels are not affected by non-disruptive conditions.

<sup>8</sup> Exceeding the limit can cause a conversion error on both stressed and unstressed channels. Transitions within the limit do not affect device reliability or cause permanent damage.

<sup>9</sup> Input must be current limited to the value specified. To determine the value of the required current-limiting resistor, calculate resistance values using  $V_{POSCLAMP} = V_{DDA} + 0.5\text{ V}$  and  $V_{NEGCLAMP} = -0.3\text{ V}$ , then use the larger of the calculated values.

<sup>10</sup> This condition applies to two adjacent pads on the internal pad.

<sup>11</sup> The TUE specification is always less than the sum of the INL, DNL, offset, and gain errors due to canceling errors.

<sup>12</sup> TUE does not apply to differential conversions.

<sup>13</sup> Measured at 6 MHz ADC clock. TUE with a 12 MHz ADC clock is:  $-16\text{ counts} < \text{TUE} < 16\text{ counts}$ .

<sup>14</sup> TUE includes all internal device errors such as internal reference variation (75% Ref, 25% Ref).

<sup>15</sup> Depending on the input impedance, the analog input leakage current (Table 9. DC Electrical Specifications, spec 35a) can affect the actual TUE measured on analog channels AN[12], AN[13], AN[14], AN[15].

### 3.11 H7Fb Flash Memory Electrical Characteristics

Table 14. Flash Program and Erase Specifications ( $T_A = T_L$  to  $T_H$ )

Spec	Flash Program Characteristic	Symbol	Min.	Typical <sup>1</sup>	Initial Max. <sup>2</sup>	Max. <sup>3</sup>	Unit
3	Doubleword (64 bits) program time <sup>4</sup>	$T_{dwprogram}$	—	10	—	500	$\mu$ s
4	Page program time <sup>4</sup>	$T_{pprogram}$	—	22	44 <sup>5</sup>	500	$\mu$ s
7	16 KB block pre-program and erase time	$T_{16kpperase}$	—	325	525	5000	ms
9	48 KB block pre-program and erase time	$T_{48kpperase}$	—	435	525	5000	ms
10	64 KB block pre-program and erase time	$T_{64kpperase}$	—	525	675	5000	ms
8	128 KB block pre-program and erase time	$T_{128kpperase}$	—	675	1800	7500	ms
11	Minimum operating frequency for program and erase operations <sup>6</sup>	—	25	—	—	—	MHz

<sup>1</sup> Typical program and erase times are calculated at 25 °C operating temperature using nominal supply values.

<sup>2</sup> Initial factory condition:  $\leq 100$  program/erase cycles, 25 °C, using a typical supply voltage measured at a minimum system frequency of 80 MHz.

<sup>3</sup> The maximum erase time occurs after the specified number of program/erase cycles. This maximum value is characterized but not guaranteed.

<sup>4</sup> Actual hardware programming times. This does not include software overhead.

<sup>5</sup> Page size is 128 bits (4 words).

<sup>6</sup> The read frequency of the flash can range up to the maximum operating frequency. There is no minimum read frequency condition.

Table 15. Flash EEPROM Module Life ( $T_A = T_L$  to  $T_H$ )

Spec	Characteristic	Symbol	Min.	Typical <sup>1</sup>	Unit
1a	Number of program/erase cycles per block for 16 KB, 48 KB, and 64 KB blocks over the operating temperature range ( $T_J$ )	P/E	100,000	—	cycles
1b	Number of program/erase cycles per block for 128 KB blocks over the operating temperature range ( $T_J$ )	P/E	1000	100,000	cycles
2	Data retention Blocks with 0–1,000 P/E cycles Blocks with 1,001–100,000 P/E cycles	Retention	20 5	— —	years

<sup>1</sup> Typical endurance is evaluated at 25° C. Product qualification is performed to the minimum specification. For additional information on the Freescale definition of typical endurance, refer to engineering bulletin EB619 *Typical Endurance for Nonvolatile Memory*.

## Electrical Characteristics

Table 16 shows the FLASH\_BIU settings versus frequency of operation. Refer to the device reference manual for definitions of these bit fields.

**Table 16. FLASH\_BIU Settings vs. Frequency of Operation<sup>1</sup>**

Target Maximum Frequency (MHz)	APC	RWSC	WWSC	DPFEN <sup>2</sup>	IPFEN <sup>2</sup>	PFLIM <sup>3</sup>	BFEN <sup>2</sup>
Up to and including 27 MHz <sup>4, 5</sup>	0b000	0b000	0b01	0b0 0b1	0b0 0b1	0b000 to 0b010	0b0 0b1
Up to and including 52 MHz <sup>6</sup>	0b001	0b001	0b01	0b0 0b1	0b0 0b1	0b000 to 0b010	0b0 0b1
Up to and including 77 MHz <sup>7</sup>	0b010	0b010	0b01	0b0 0b1	0b0 0b1	0b000 to 0b010	0b0 0b1
Up to and including 82 MHz <sup>8</sup>	0b011	0b011	0b01	0b0 0b1	0b0 0b1	0b000 to 0b010	0b0 0b1
Reset values:	0b111	0b111	0b11	0b0	0b0	0b000	0b0

<sup>1</sup> Illegal combinations exist. Use entries from the same row in this table.

<sup>2</sup> For maximum flash performance, set to 0b1.

<sup>3</sup> For maximum flash performance, set to 0b010.

<sup>4</sup> 27 MHz parts allow for 25 MHz system clock + 2% frequency modulation (FM).

<sup>5</sup> The APC, RWSC, and WWSC combination requires setting the PRD bit to 1 in the flash MCR register.

<sup>6</sup> 52 MHz parts allow for 50 MHz system clock + 2% FM.

<sup>7</sup> 77 MHz parts allow for 75 MHz system clock + 2% FM.

<sup>8</sup> 82 MHz parts allow for 80 MHz system clock + 2% FM.



## 3.12 AC Specifications

### 3.12.1 Pad AC Specifications

Table 17. Pad AC Specifications ( $V_{DDEH} = 5.0\text{ V}$ ,  $V_{DDE} = 1.8\text{ V}$ )<sup>1</sup>

Spec	Pad	SRC / DSC (binary)	Out Delay (ns) <sup>2, 3, 4</sup>	Rise / Fall (ns) <sup>4, 5</sup>	Load Drive (pF)
1	Slow high voltage (SH)	11	26	15	50
			82	60	200
		01	75	40	50
			137	80	200
		00	377	200	50
			476	260	200
2	Medium high voltage (MH)	11	16	8	50
			43	30	200
		01	34	15	50
			61	35	200
		00	192	100	50
			239	125	200
3	Fast	00	3.1	2.7	10
		01		2.5	20
		10		2.4	30
		11		2.3	50
4	Pullup/down (3.6 V max)	—	—	7500	50
5	Pullup/down (5.5 V max)	—	—	9000	50

<sup>1</sup> These are worst-case values that are estimated from simulation (not tested). The values in the table are simulated at:  $V_{DD} = 1.35\text{--}1.65\text{ V}$ ;  $V_{DDE} = 1.62\text{--}1.98\text{ V}$ ;  $V_{DDEH} = 4.5\text{--}5.25\text{ V}$ ;  $V_{DD33}$  and  $V_{DDSYN} = 3.0\text{--}3.6\text{ V}$ ; and  $T_A = T_L$  to  $T_H$ .

<sup>2</sup> This parameter is supplied for reference and is guaranteed by design (not tested).

<sup>3</sup> The output delay is shown in [Figure 4](#). To calculate the output delay with respect to the system clock, add a maximum of one system clock to the output delay.

<sup>4</sup> The output delay and rise and fall are measured to 20% or 80% of the respective signal.

<sup>5</sup> This parameter is guaranteed by characterization rather than 100% tested.

## Electrical Characteristics

**Table 18. Derated Pad AC Specifications ( $V_{DDEH} = 3.3\text{ V}$ ,  $V_{DDE} = 3.3\text{ V}$ )<sup>1</sup>**

Spec	Pad	SRC/DSC (binary)	Out Delay <sup>2, 3, 4</sup> (ns)	Rise / Fall <sup>3, 5</sup> (ns)	Load Drive (pF)
1	Slow high voltage (SH)	11	39	23	50
			120	87	200
		01	101	52	50
			188	111	200
		00	507	248	50
			597	312	200
2	Medium high voltage (MH)	11	23	12	50
			64	44	200
		01	50	22	50
			90	50	200
		00	261	123	50
			305	156	200
3	Fast	00	3.2	2.4	10
		01		2.2	20
		10		2.1	30
		11		2.1	50
4	Pullup/down (3.6 V max)	—	—	7500	50
5	Pullup/down (5.5 V max)	—	—	9500	50

<sup>1</sup> These are worst-case values that are estimated from simulation (not tested). The values in the table are simulated at:  $V_{DD} = 1.35\text{--}1.65\text{ V}$ ;  $V_{DDE} = 3.0\text{--}3.6\text{ V}$ ;  $V_{DDEH} = 3.0\text{--}3.6\text{ V}$ ;  $V_{DD33}$  and  $V_{DDSYN} = 3.0\text{--}3.6\text{ V}$ ; and  $T_A = T_L$  to  $T_H$ .

<sup>2</sup> This parameter is supplied for reference and guaranteed by design (not tested).

<sup>3</sup> The output delay, and the rise and fall, are calculated to 20% or 80% of the respective signal.

<sup>4</sup> The output delay is shown in [Figure 4](#). To calculate the output delay with respect to the system clock, add a maximum of one system clock to the output delay.

<sup>5</sup> This parameter is guaranteed by characterization rather than 100% tested.

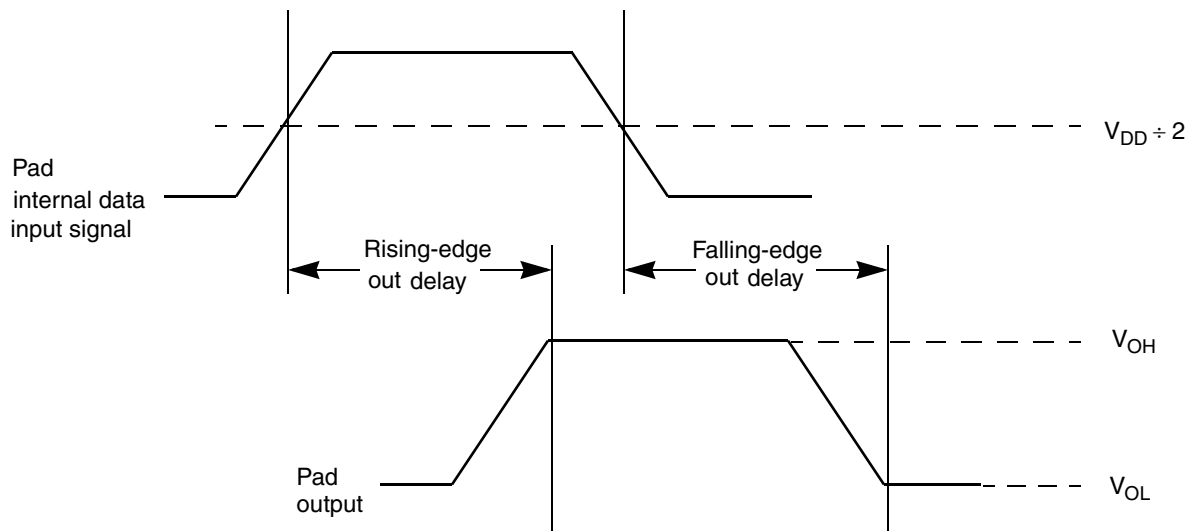

Figure 4. Pad Output Delay

### 3.13 AC Timing

#### 3.13.1 Reset and Configuration Pin Timing

Table 19. Reset and Configuration Pin Timing <sup>1</sup>

Spec	Characteristic	Symbol	Min.	Max.	Unit
1	$\overline{\text{RESET}}$ pulse width	$t_{\text{RPW}}$	10	—	$t_{\text{CYC}}$
2	$\overline{\text{RESET}}$ glitch detect pulse width	$t_{\text{GPW}}$	2	—	$t_{\text{CYC}}$
3	PLLCFG, BOOTCFG, WKPCFG, $\overline{\text{RSTCFG}}$ setup time to $\overline{\text{RSTOUT}}$ valid	$t_{\text{RCSU}}$	10	—	$t_{\text{CYC}}$
4	PLLCFG, BOOTCFG, WKPCFG, $\overline{\text{RSTCFG}}$ hold time from $\overline{\text{RSTOUT}}$ valid	$t_{\text{RCH}}$	0	—	$t_{\text{CYC}}$

<sup>1</sup> Reset timing specified at:  $V_{\text{DDEH}} = 3.0\text{--}5.25\text{ V}$  and  $T_{\text{A}} = T_{\text{L}}$  to  $T_{\text{H}}$ .

## Electrical Characteristics

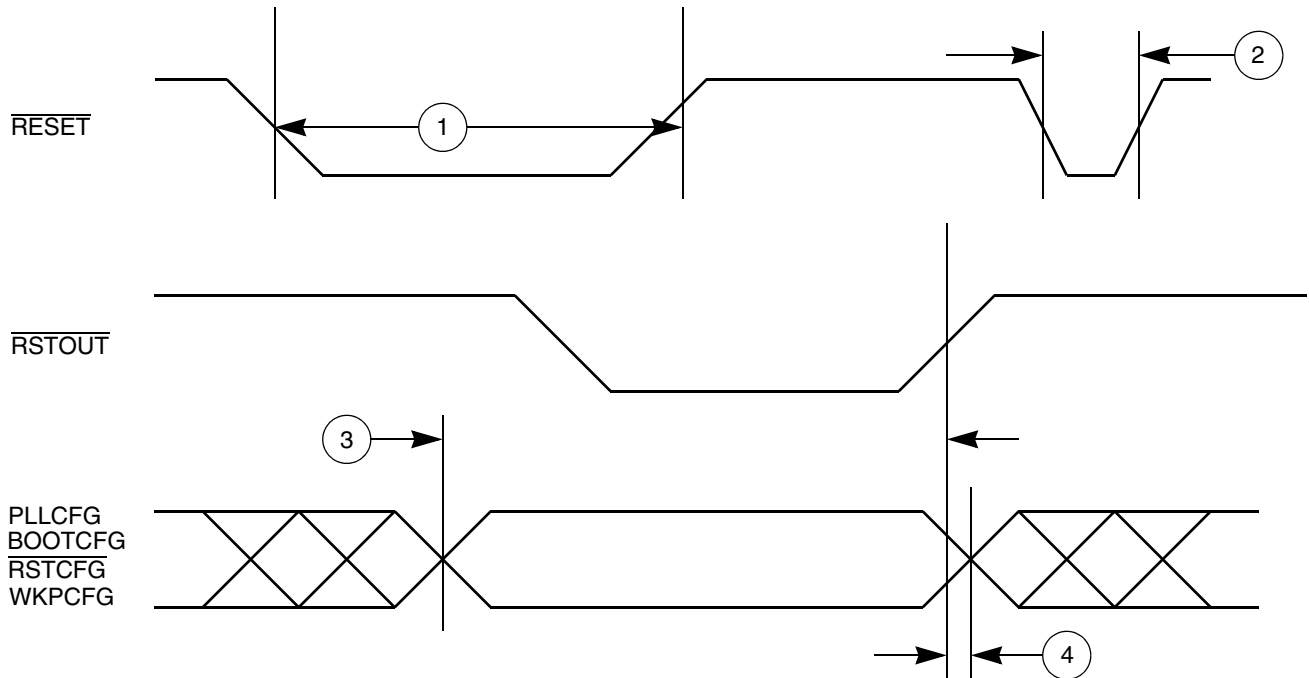

Figure 5. Reset and Configuration Pin Timing

### 3.13.2 IEEE 1149.1 Interface Timing

Table 20. JTAG Pin AC Electrical Characteristics <sup>1</sup>

Spec	Characteristic	Symbol	Min.	Max.	Unit
1	TCK cycle time	$t_{JCYC}$	100	—	ns
2	TCK clock pulse width (measured at $V_{DDE} \div 2$ )	$t_{JDC}$	40	60	ns
3	TCK rise and fall times (40% to 70%)	$t_{TCKRISE}$	—	3	ns
4	TMS, TDI data setup time	$t_{TMSS}, t_{TDIS}$	5	—	ns
5	TMS, TDI data hold time	$t_{TMSH}, t_{TDIH}$	25	—	ns
6	TCK low to TDO data valid	$t_{TDOV}$	—	20	ns
7	TCK low to TDO data invalid	$t_{TDOI}$	0	—	ns
8	TCK low to TDO high impedance	$t_{TDOHZ}$	—	20	ns
9	JCOMP assertion time	$t_{JCMPPW}$	100	—	ns
10	JCOMP setup time to TCK low	$t_{JCMPS}$	40	—	ns
11	TCK falling-edge to output valid	$t_{BSDV}$	—	50	ns
12	TCK falling-edge to output valid out of high impedance	$t_{BSDVZ}$	—	50	ns
13	TCK falling-edge to output high impedance (Hi-Z)	$t_{BSDHZ}$	—	50	ns
14	Boundary scan input valid to TCK rising-edge	$t_{BSDST}$	50	—	ns
15	TCK rising-edge to boundary scan input invalid	$t_{BSDHT}$	50	—	ns

<sup>1</sup> These specifications apply to JTAG boundary scan only. JTAG timing specified at:  $V_{DDE} = 3.0\text{--}3.6\text{ V}$  and  $T_A = T_L$  to  $T_H$ . Refer to [Table 21](#) for Nexus specifications.

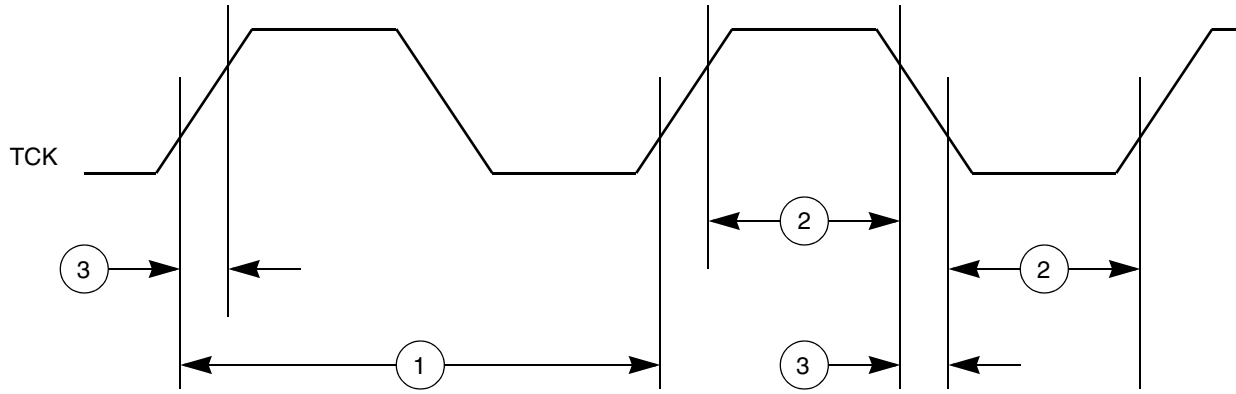

Figure 6. JTAG Test Clock Input Timing

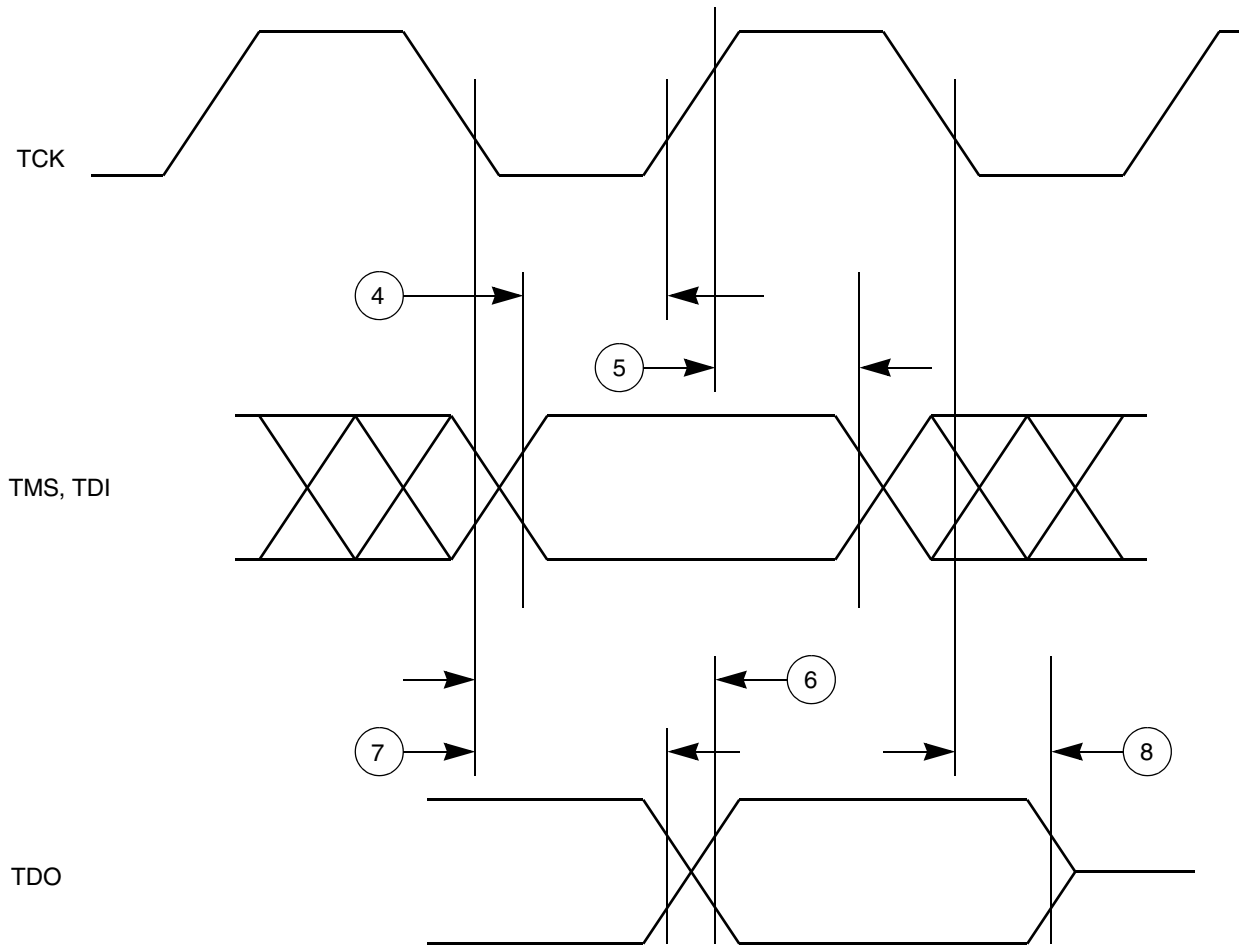

Figure 7. JTAG Test Access Port Timing

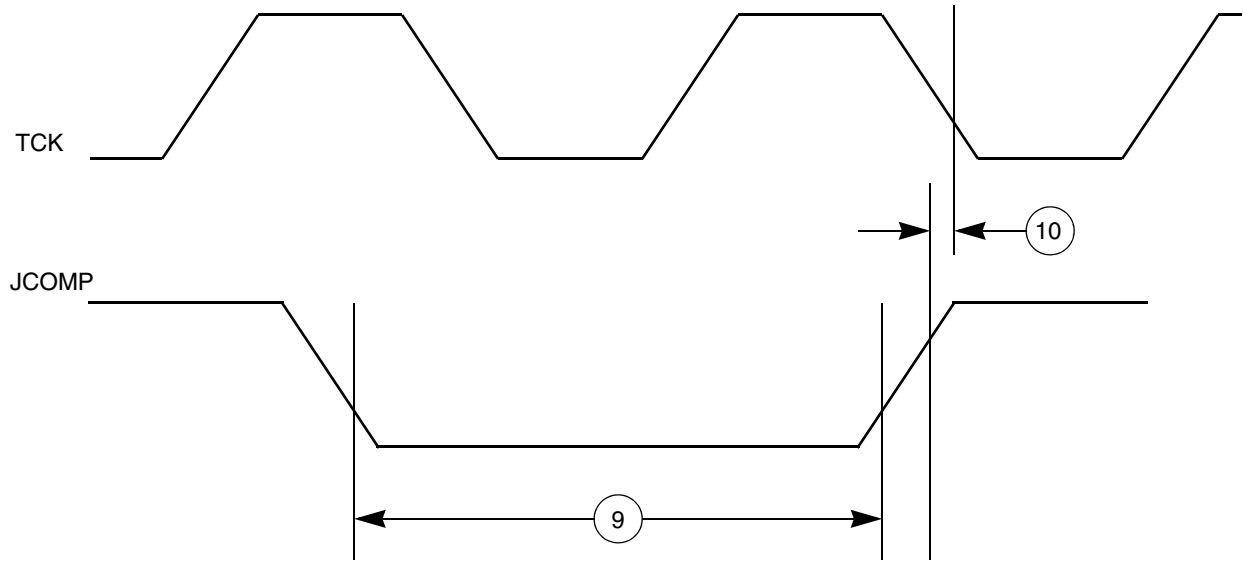

Figure 8. JTAG JCOMP Timing

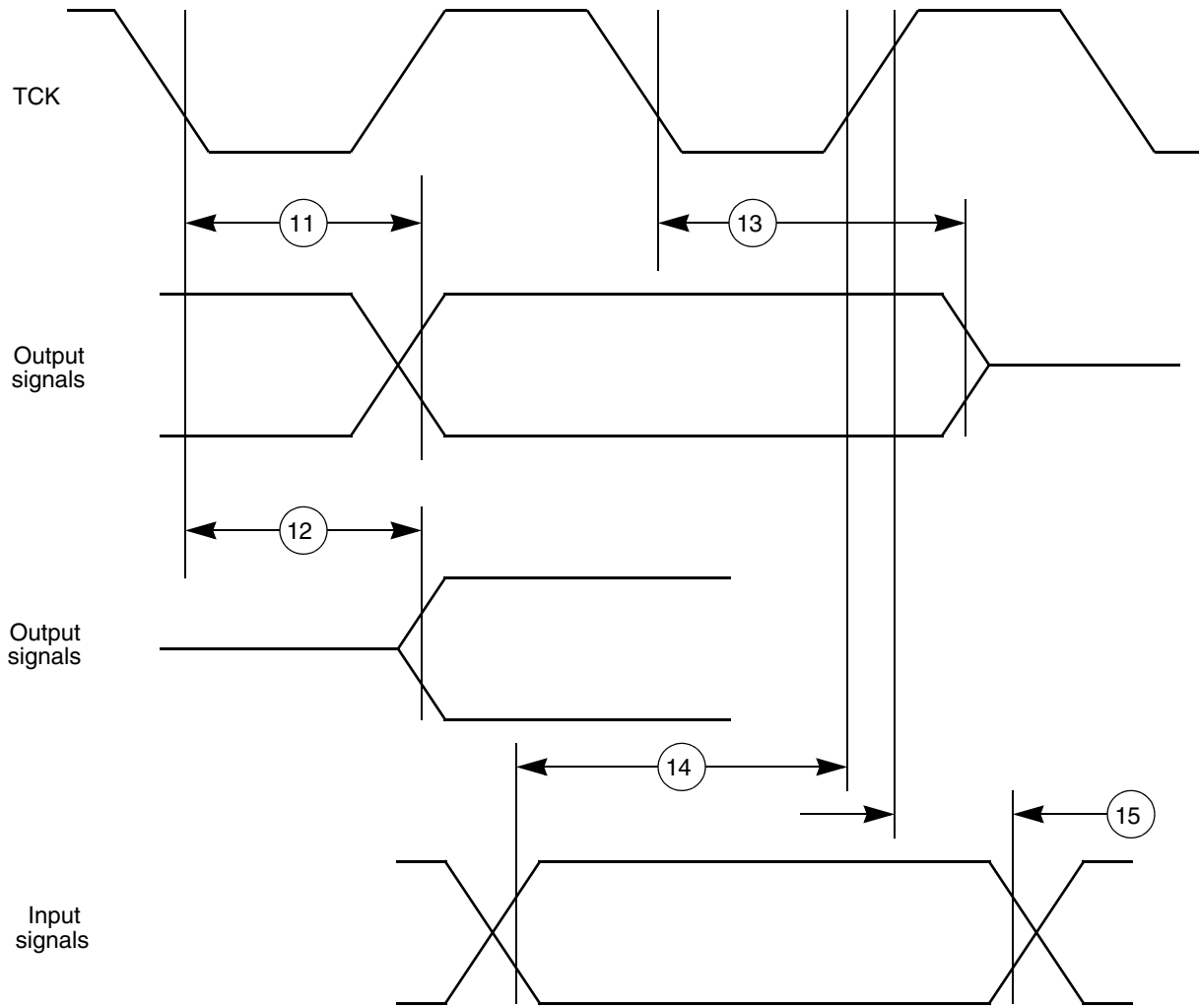

Figure 9. JTAG Boundary Scan Timing

### 3.13.3 Nexus Timing

Table 21. Nexus Debug Port Timing <sup>1</sup>

Spec	Characteristic	Symbol	Min.	Max.	Unit
1	MCKO cycle time	$t_{MICYC}$	1 <sup>2</sup>	8	$t_{CYC}$
2	MCKO duty cycle	$t_{MDC}$	40	60	%
3	MCKO low to MDO data valid <sup>3</sup>	$t_{MDOV}$	-1.5	3.0	ns
4	MCKO low to $\overline{MSEO}$ data valid <sup>3</sup>	$t_{MSEOV}$	-1.5	3.0	ns
5	MCKO low to $\overline{EVTO}$ data valid <sup>3</sup>	$t_{EVTOV}$	-1.5	3.0	ns
6	$\overline{EVTI}$ pulse width	$t_{EVTIPW}$	4.0	—	$t_{TCYC}$
7	$\overline{EVTO}$ pulse width	$t_{EVTOPW}$	1	—	$t_{MICYC}$
8	TCK cycle time	$t_{TCYC}$	4 <sup>4</sup>	—	$t_{CYC}$
9	TCK duty cycle	$t_{TDC}$	40	60	%
10	TDI, TMS data setup time	$t_{NTDIS}, t_{NTMSS}$	8	—	ns
11	TDI, TMS data hold time	$t_{NTDIH}, t_{NTMSH}$	5	—	ns
12	TCK low to TDO data valid	$t_{JOV}$	0	12	ns
	$V_{DDE} = 2.25-3.0$ V $V_{DDE} = 3.0-3.6$ V		0	10	ns
13	$\overline{RDY}$ valid to MCKO <sup>5</sup>	—	—	—	—

<sup>1</sup> JTAG specifications apply when used for debug functionality. All Nexus timing relative to MCKO is measured from 50% of MCKO and 50% of the respective signal. Nexus timing specified at  $V_{DD} = 1.35-1.65$  V,  $V_{DDE} = 2.25-3.6$  V,  $V_{DD33}$  and  $V_{DDSYN} = 3.0-3.6$  V,  $T_A = T_L$  to  $T_H$ , and  $CL = 30$  pF with  $DSC = 0b10$ .

<sup>2</sup> The Nexus AUX port runs up to 82 MHz.

<sup>3</sup> MDO,  $\overline{MSEO}$ , and  $\overline{EVTO}$  data is held valid until the next MCKO low cycle occurs.

<sup>4</sup> Limit the maximum frequency to approximately 16 MHz ( $V_{DDE} = 2.25-3.0$  V) or 20 MHz ( $V_{DDE} = 3.0-3.6$  V) to meet the timing specification for  $t_{JOV}$  of  $[0.2 \times t_{JCYC}]$  as outlined in the IEEE-ISTO 5001-2003 specification.

<sup>5</sup> The  $\overline{RDY}$  pin timing is asynchronous to MCKO and is guaranteed by design to function correctly.

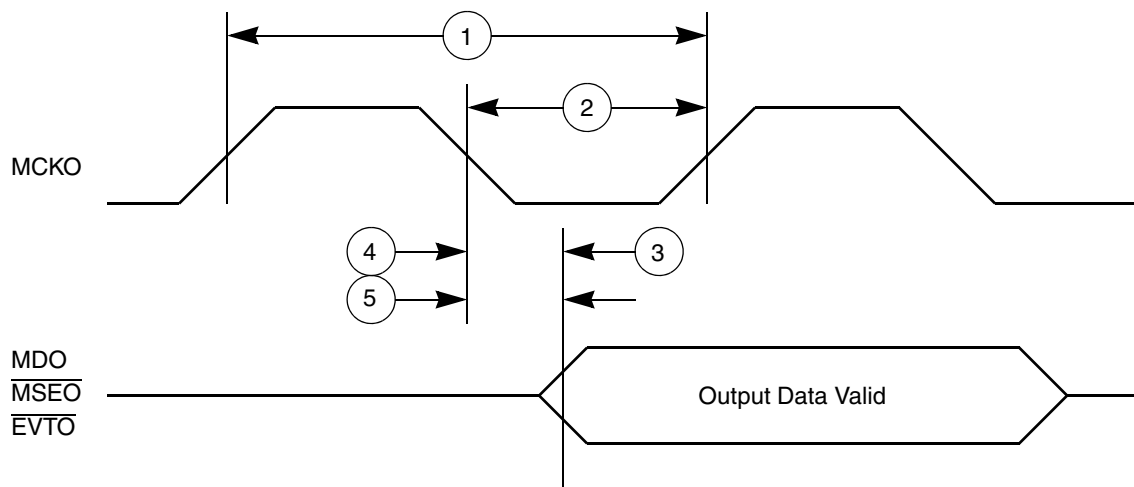

Figure 10. Nexus Output Timing



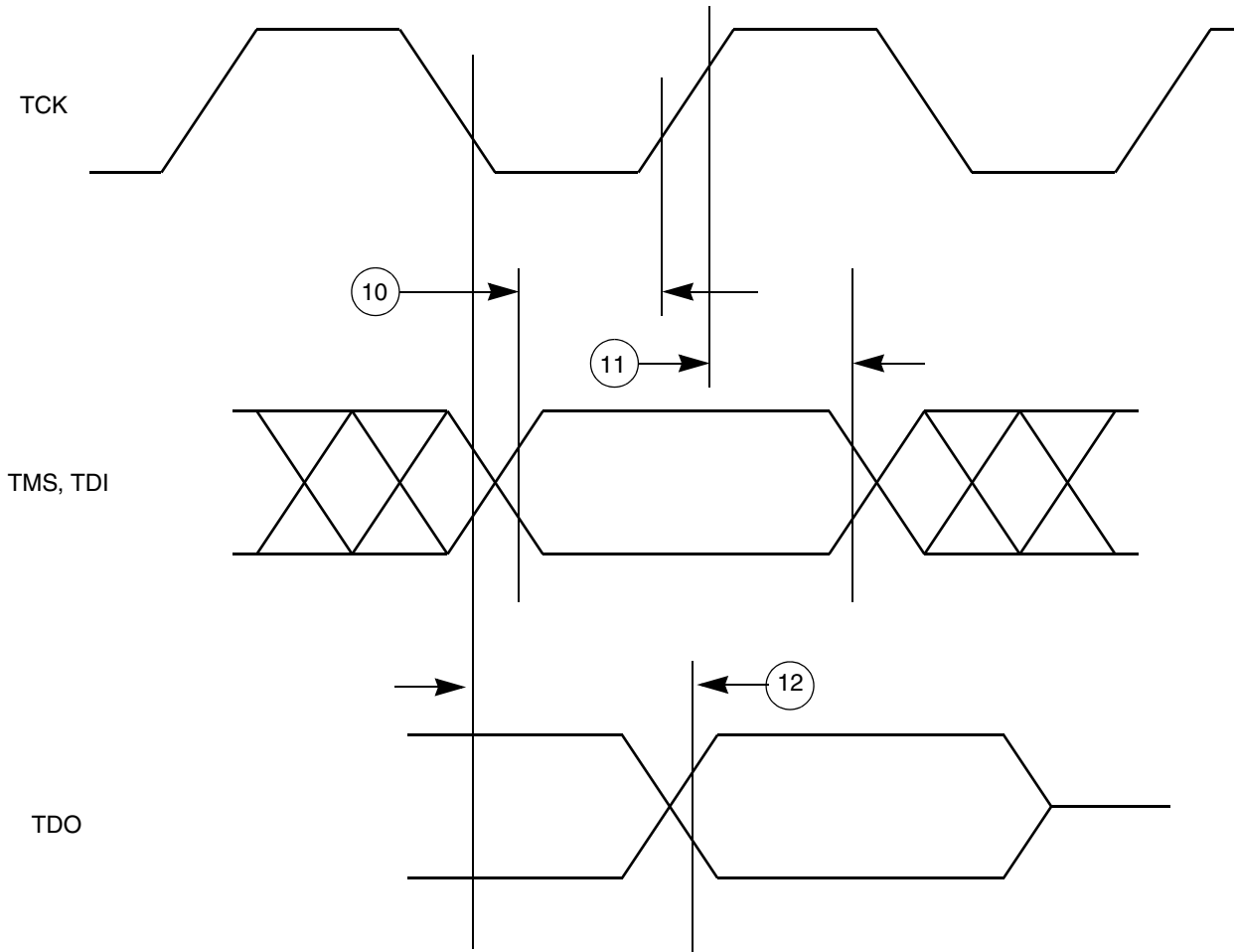

Figure 11. Nexus TDI, TMS, TDO Timing

### 3.13.4 External Bus Interface (EBI) Timing

Table 22 lists the timing information for the external bus interface (EBI).

**Table 22. External Bus Operation Timing<sup>1, 2</sup>**

Spec	Characteristic and Description	Symbol	External Bus Frequency <sup>3</sup>						Unit	Notes
			20 MHz		33 MHz		40 MHz			
			Min.	Max	Min.	Max	Min.	Max		
1	CLKOUT period	$T_C$	24.4	—	17.5	—	14.9	—	ns	Signals are measured at 50% $V_{DDE}$ .
2	CLKOUT duty cycle	$t_{CDC}$	45%	55%	45%	55%	45%	55%	$T_C$	
3	CLKOUT rise time	$t_{CRT}$	—	— <sup>4</sup>	—	—	—	— <sup>4</sup>	ns	
4	CLKOUT fall time	$t_{CFT}$	—	— <sup>4</sup>	—	— <sup>4</sup>	—	— <sup>4</sup>	ns	
5 <sup>5</sup>	CLKOUT positive edge to output signal <i>invalid</i> or Hi-Z (hold time)  External bus interface $\overline{CS}[0:3]$ ADDR[8:31] DATA[0:15] $\overline{RD\_WR}$ $\overline{BDIP}$ $\overline{WE/BE}[0:1]$ $\overline{OE}$ $\overline{TS}$ $\overline{TA}$	$t_{COH}$	1.0 <sup>6</sup>	—	1.0 <sup>6</sup>	—	1.0 <sup>6</sup>	—	ns	EBTS = 0  EBTS = 1  Hold time selectable via SIU_ECCR [EBTS] bit.
			1.5	—	1.5	—	1.5	—		
6 <sup>5</sup>	CLKOUT positive edge to output signal <i>valid</i> (output delay)  External bus interface $\overline{CS}[0:3]$ ADDR[8:31] DATA[0:15] $\overline{RD\_WR}$ $\overline{BDIP}$ $\overline{WE/BE}[0:1]$ $\overline{OE}$ $\overline{TS}$ $\overline{TA}$	$t_{COV}$	—	10.0 <sup>6</sup>	—	10.0 <sup>6</sup>	—	10.0 <sup>6</sup>	ns	EBTS = 0  EBTS = 1  Output valid time selectable via SIU_ECCR [EBTS] bit.
			—	11.0	—	11.0	—	11.0		

Table 22. External Bus Operation Timing<sup>1, 2</sup> (continued)

Spec	Characteristic and Description	Symbol	External Bus Frequency <sup>3</sup>						Unit	Notes
			20 MHz		33 MHz		40 MHz			
			Min.	Max.	Min.	Max.	Min.	Max.		
7 <sup>5</sup>	Input signal valid to CLKOUT positive edge (setup time)  External bus interface ADDR[8:31] DATA[0:15] RD_ $\overline{WR}$ $\overline{TS}$ $\overline{TA}$	$t_{CIS}$	10.0	—	10.0	—	10.0	—	ns	
8 <sup>5</sup>	CLKOUT positive edge to input signal invalid (hold time)  External bus interface ADDR[8:31] DATA[0:15] RD_ $\overline{WR}$ $\overline{TS}$ $\overline{TA}$	$t_{CIH}$	1.0	—	1.0	—	1.0	—	ns	

<sup>1</sup> EBI timing specified at  $V_{DDE} = 1.6\text{--}3.6$  V (unless stated otherwise),  $T_A = T_L$  to  $T_H$ , and  $CL = 30$  pF with  $DSC = 0b10$ .

<sup>2</sup> The external bus is limited to half the speed of the internal bus.

<sup>3</sup> Speed is the nominal maximum frequency. Max speed is the maximum speed allowed including frequency modulation (FM). 42 MHz parts allow for 40 MHz system clock + 2% FM; 68 MHz parts allow for a 66 MHz system clock + 2% FM, and 82 MHz parts allow for 80 MHz system clock + 2% FM.

<sup>4</sup> Refer to fast pad timing in Table 17 and Table 18 (different values for 1.8 V and 3.3 V).

<sup>5</sup> Available on the 324 package only; not available on the 208 package.

<sup>6</sup> EBTS = 0 timings are tested and valid at  $V_{DDE} = 2.25\text{--}3.6$  V only; EBTS = 1 timings are tested and valid at  $V_{DDE} = 1.6\text{--}3.6$  V.

### 3.13.5 External Interrupt Timing (IRQ Signals)

Table 23. External Interrupt Timing<sup>1</sup>

Spec	Characteristic	Symbol	Min.	Max.	Unit
1	IRQ pulse-width low	$t_{IPWL}$	3	—	$t_{CYC}$
2	IRQ pulse-width high	$T_{IPWH}$	3	—	$t_{CYC}$
3	IRQ edge-to-edge time <sup>2</sup>	$t_{ICYC}$	6	—	$t_{CYC}$

<sup>1</sup> IRQ timing specified at:  $V_{DDEH} = 3.0\text{--}5.25$  V and  $T_A = T_L$  to  $T_H$ .

<sup>2</sup> Applies when IRQ signals are configured for rising-edge or falling-edge events, but not both.



## 3.13.7 DSPI Timing

Table 25. DSPI Timing <sup>1, 2</sup>

Spec	Characteristic	Symbol	40 MHz		66 MHz		80 MHz		Unit
			Min.	Max	Min.	Max	Min.	Max	
1	SCK cycle time <sup>3, 4</sup>	$t_{SCK}$	48.8 ns	5.8 ms	28.4 ns	3.5 ms	24.4 ns	2.9 ms	—
2	PCS to SCK delay <sup>5</sup>	$t_{CSC}$	46	—	26	—	22	—	ns
3	After SCK delay <sup>6</sup>	$t_{ASC}$	45	—	25	—	21	—	ns
4	SCK duty cycle	$t_{SDC}$	$(t_{SCK} \div 2) - 2$ ns	$(t_{SCK} \div 2) + 2$ ns	$(t_{SCK} \div 2) - 2$ ns	$(t_{SCK} \div 2) + 2$ ns	$(t_{SCK} \div 2) - 2$ ns	$(t_{SCK} \div 2) + 2$ ns	ns
5	Slave access time ( $\overline{SS}$ active to SOUT driven)	$t_A$	—	25	—	25	—	25	ns
6	Slave SOUT disable time ( $\overline{SS}$ inactive to SOUT Hi-Z, or invalid)	$t_{DIS}$	—	25	—	25	—	25	ns
7	PCSx to PCSS time	$t_{PCSC}$	4	—	4	—	4	—	ns
8	PCSS to PCSx time	$t_{PASC}$	5	—	5	—	5	—	ns
9	Data setup time for inputs	$t_{SUI}$							
	Master (MTFE = 0)		20	—	20	—	20	—	ns
	Slave		2	—	2	—	2	—	ns
	Master (MTFE = 1, CPHA = 0) <sup>7</sup>		-4	—	6	—	8	—	ns
	Master (MTFE = 1, CPHA = 1)		20	—	20	—	20	—	ns
10	Data hold time for inputs	$t_{HI}$							
	Master (MTFE = 0)		-4	—	-4	—	-4	—	ns
	Slave		7	—	7	—	7	—	ns
	Master (MTFE = 1, CPHA = 0) <sup>7</sup>		45	—	25	—	21	—	ns
	Master (MTFE = 1, CPHA = 1)		-4	—	-4	—	-4	—	ns
11	Data valid (after SCK edge)	$t_{SUO}$							
	Master (MTFE = 0)		—	5	—	5	—	5	ns
	Slave		—	25	—	25	—	25	ns
	Master (MTFE = 1, CPHA = 0)		—	45	—	25	—	21	ns
	Master (MTFE = 1, CPHA = 1)		—	5	—	5	—	5	ns
12	Data hold time for outputs	$t_{HO}$							
	Master (MTFE = 0)		-5	—	-5	—	-5	—	ns
	Slave		5.5	—	5.5	—	5.5	—	ns
	Master (MTFE = 1, CPHA = 0)		8	—	4	—	3	—	ns
	Master (MTFE = 1, CPHA = 1)		-5	—	-5	—	-5	—	ns

<sup>1</sup> All DSPI timing specifications use the fastest slew rate (SRC = 0b11) on pad type M or MH. DSPI signals using pad types of S or SH have an additional delay based on the slew rate. DSPI timing is specified at  $V_{DDEH} = 3.0\text{--}5.25$  V,  $T_A = T_L$  to  $T_H$ , and  $CL = 50$  pF with SRC = 0b11.

<sup>2</sup> Speed is the nominal maximum frequency. Max speed is the maximum speed allowed including frequency modulation (FM). 42 MHz parts allow for 40 MHz system clock + 2% FM; 68 MHz parts allow for a 66 MHz system clock + 2% FM, and 82 MHz parts allow for 80 MHz system clock + 2% FM.

<sup>3</sup> The minimum SCK cycle time restricts the baud rate selection for the given system clock rate. These numbers are calculated based on two MPC55xx devices communicating over a DSPI link.

<sup>4</sup> The actual minimum SCK cycle time is limited by pad performance.

<sup>5</sup> The maximum value is programmable in DSPI\_CTARx[PSSCK] and DSPI\_CTARx[CSSCK].

<sup>6</sup> The maximum value is programmable in DSPI\_CTARx[PASC] and DSPI\_CTARx[ASC].

<sup>7</sup> This number is calculated using the SMPL\_PT field in DSPI\_MCR set to 0b10.

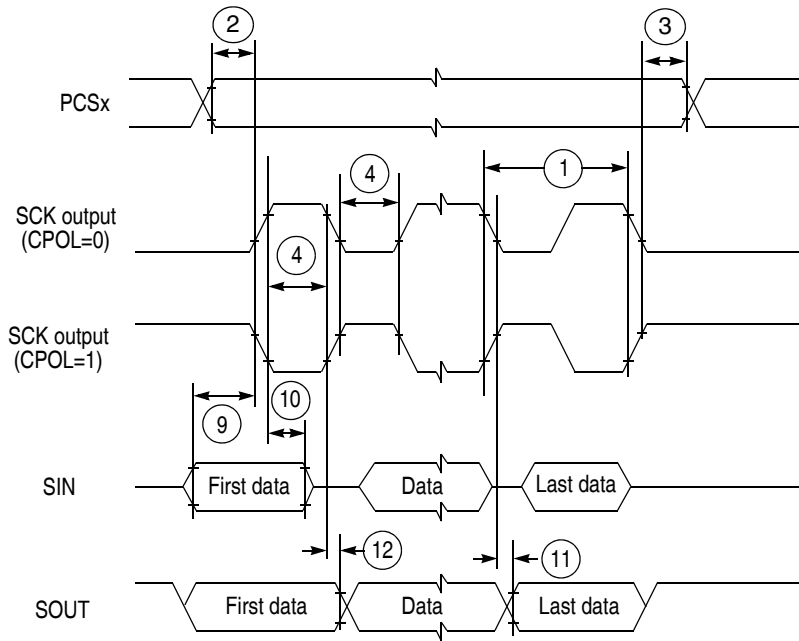

Figure 14. DSPI Classic SPI Timing—Master, CPHA = 0

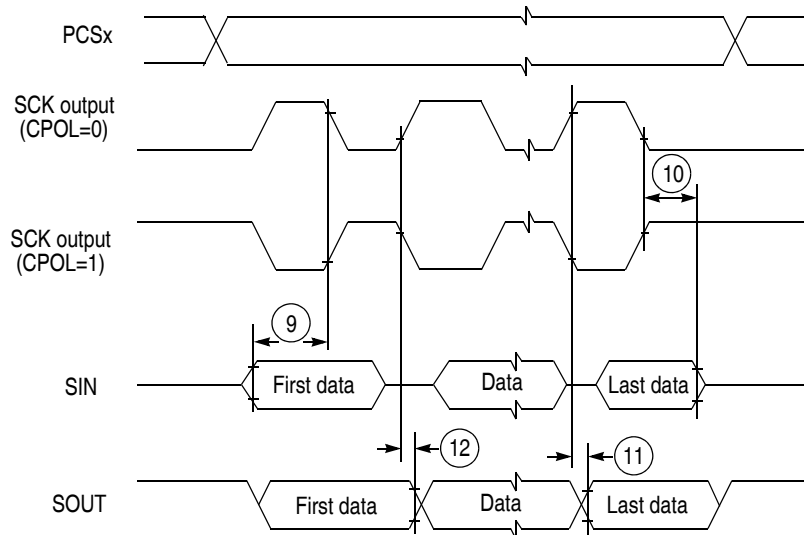

Figure 15. DSPI Classic SPI Timing—Master, CPHA = 1

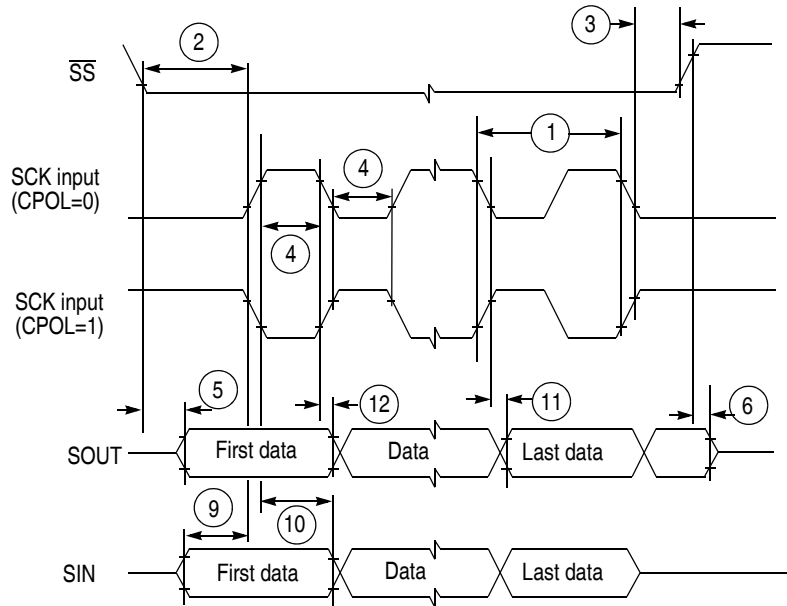

Figure 16. DSPI Classic SPI Timing—Slave, CPHA = 0

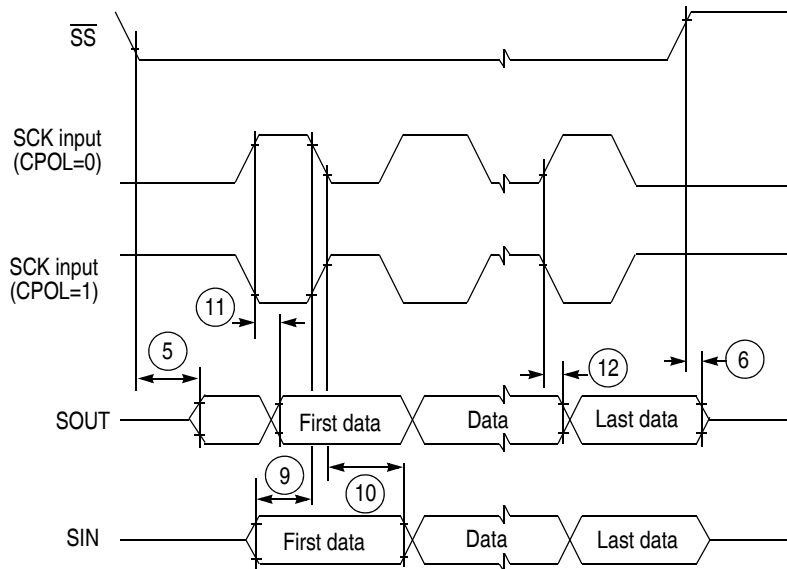

Figure 17. DSPI Classic SPI Timing—Slave, CPHA = 1

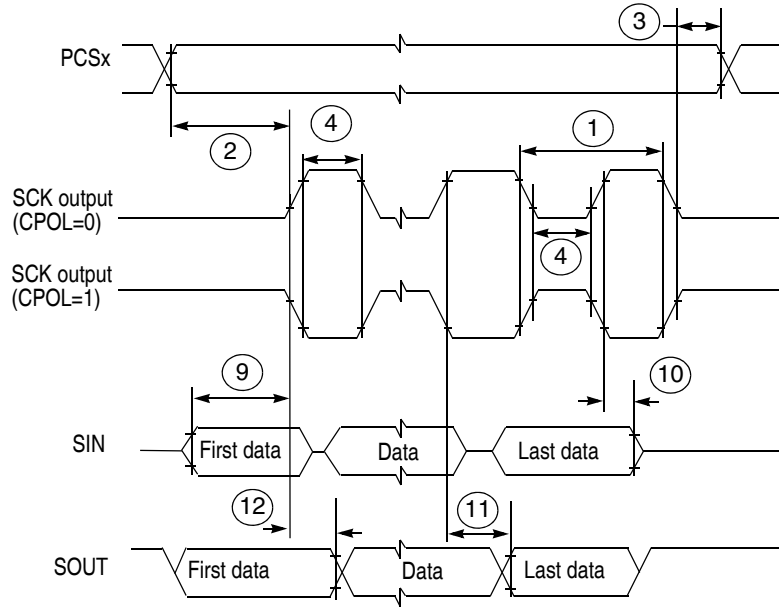

Figure 18. DSPI Modified Transfer Format Timing—Master, CPHA = 0

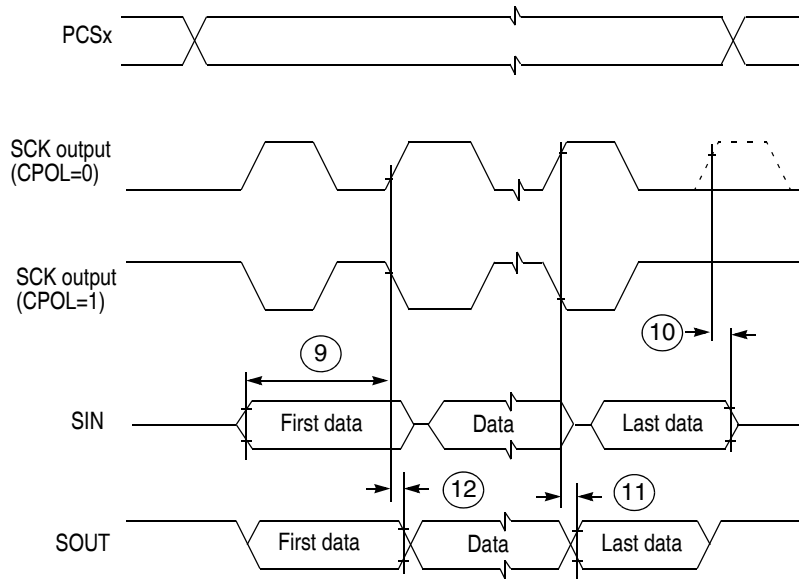

Figure 19. DSPI Modified Transfer Format Timing—Master, CPHA = 1



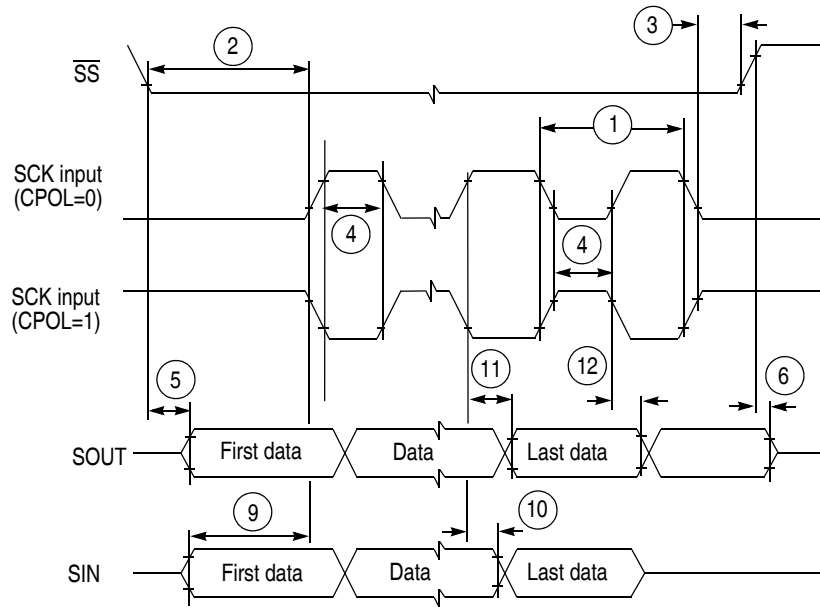

Figure 20. DSPI Modified Transfer Format Timing—Slave, CPHA = 0

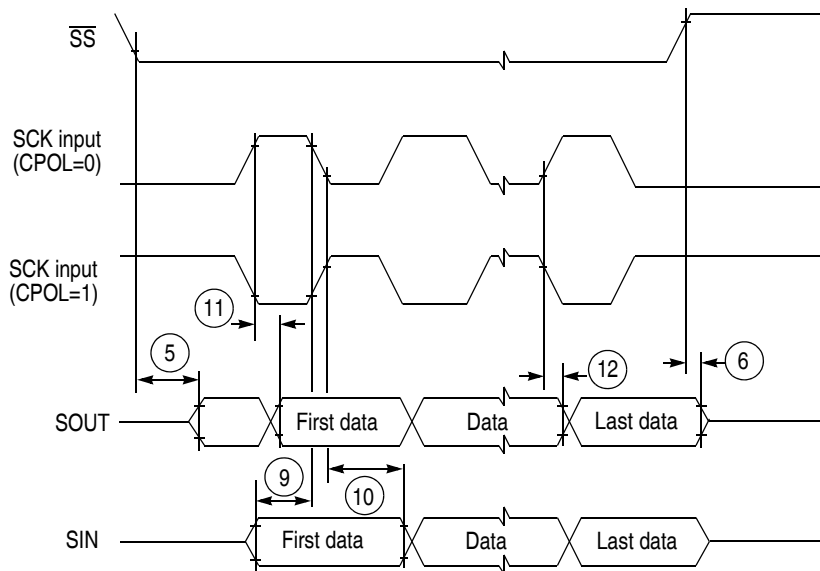

Figure 21. DSPI Modified Transfer Format Timing—Slave, CPHA = 1

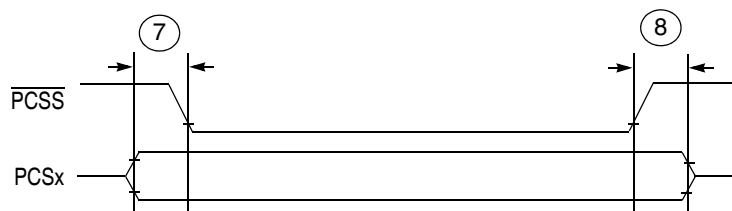

Figure 22. DSPI PCS Strobe ( $\overline{PCSS}$ ) Timing

### 3.13.8 eQADC SSI Timing

Table 26. EQADC SSI Timing Characteristics

Spec	Rating	Symbol	Minimum	Typical	Maximum	Unit
2	FCK period ( $t_{FCK} = 1 \div f_{FCK}$ ) <sup>1, 2</sup>	$t_{FCK}$	2	—	17	$t_{SYS\_CLK}$
3	Clock (FCK) high time	$t_{FCKHT}$	$t_{SYS\_CLK} - 6.5$	—	$9 \times (t_{SYS\_CLK} + 6.5)$	ns
4	Clock (FCK) low time	$t_{FCKLT}$	$t_{SYS\_CLK} - 6.5$	—	$8 \times (t_{SYS\_CLK} + 6.5)$	ns
5	SDS lead / lag time	$t_{SDS\_LL}$	-7.5	—	+7.5	ns
6	SDO lead / lag time	$t_{SDO\_LL}$	-7.5	—	+7.5	ns
7	EQADC data setup time (inputs)	$t_{EQ\_SU}$	22	—	—	ns
8	EQADC data hold time (inputs)	$t_{EQ\_HO}$	1	—	—	ns

<sup>1</sup> SS timing specified at  $V_{DDEH} = 3.0-5.25$  V,  $T_A = T_L$  to  $T_H$ , and  $CL = 25$  pF with  $SRC = 0b11$ . Maximum operating frequency varies depending on track delays, master pad delays, and slave pad delays.

<sup>2</sup> FCK duty cycle is not 50% when it is generated through the division of the system clock by an odd number.

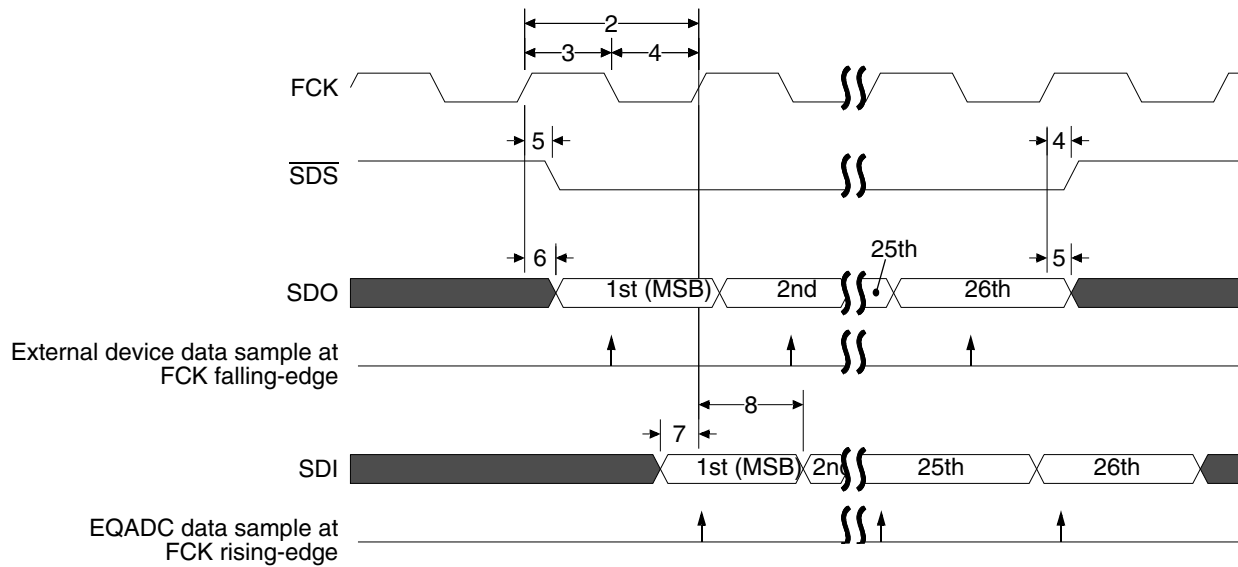

Figure 23. EQADC SSI Timing

## 4 Mechanicals

### 4.1 MPC5533 208 MAP BGA Pinout

Figure 24 is a pinout for the MPC5533 208 MAP BGA package.

#### NOTES

$V_{DDEH10}$  and  $V_{DDEH6}$  are connected internally on the 208-ball package and are listed as  $V_{DDEH6}$ .

The MPC5500 devices are pin compatible for software portability and use the primary function names to label the pins in the BGA diagram. Although some devices do not support all the primary functions shown in the BGA diagram, the muxed and GPIO signals on those pins remain available. See the signals chapter in the device reference manual for the signal muxing.

	1	2	3	4	5	6	7	8	9	10	11	12	13	14	15	16	
A	VSS	AN9	AN11	VDDA1	VSSA1	AN1	AN5	VRH	VRL	AN27	VSSA0	AN12	MDO2	MDO0	VDD33	VSS	A
B	VDD	VSS	AN38	AN21	AN0	AN4	REF BYPC	AN22	AN25	AN28	VDDA0	AN13	MDO3	MDO1	VSS	VDD	B
C	VSTBY	VDD	VSS	AN17	AN34	AN16	AN3	AN7	AN23	AN32	AN33	AN14	AN15	VSS	MSE00	TCK	C
D	VDD33	AN39	VDD	VSS	AN18	AN2	AN6	AN24	AN30	AN31	AN35	VDDEH <sub>9</sub>	VSS	TMS	EVTO	TEST	D
E	ETPUA <sub>30</sub>	ETPUA <sub>31</sub>	AN37	VDD									VDDE7	TDI	EVTI	MSE01	E
F	ETPUA <sub>28</sub>	ETPUA <sub>29</sub>	ETPUA <sub>26</sub>	AN36									VDDEH <sub>6</sub>	TDO	MCKO	JCOMP	F
G	ETPUA <sub>24</sub>	ETPUA <sub>27</sub>	ETPUA <sub>25</sub>	ETPUA <sub>21</sub>			VSS	VSS	VSS	VSS			SOUTB	PCSB3	SINB	PCSB0	G
H	ETPUA <sub>23</sub>	ETPUA <sub>22</sub>	ETPUA <sub>17</sub>	ETPUA <sub>18</sub>			VSS	VSS	VSS	VSS			PCSA3	PCSB4	PCSB2	PCSB1	H
J	ETPUA <sub>20</sub>	ETPUA <sub>19</sub>	ETPUA <sub>14</sub>	ETPUA <sub>13</sub>			VSS	VSS	VSS	VSS			PCSB5	TXDA	PCSA2	SCKB	J
K	ETPUA <sub>16</sub>	ETPUA <sub>15</sub>	ETPUA <sub>7</sub>	VDDEH <sub>1</sub>			VSS	VSS	VSS	VSS			CNTXC	RXDA	RSTOUT	VPP	K
L	ETPUA <sub>12</sub>	ETPUA <sub>11</sub>	ETPUA <sub>6</sub>	TCRCLK <sub>A</sub>									TXDB	CNRXC	WKP <sub>CFG</sub>	RESET	L
M	ETPUA <sub>10</sub>	ETPUA <sub>9</sub>	ETPUA <sub>1</sub>	ETPUA <sub>5</sub>									RXDB	PLL <sub>CFG0</sub>	BOOT <sub>CFG1</sub>	VSS <sub>SYN</sub>	M
N	ETPUA <sub>8</sub>	ETPUA <sub>4</sub>	ETPUA <sub>0</sub>	VSS	VDD	VDD33	EMIOS <sub>2</sub>	EMIOS <sub>10</sub>	VDDEH <sub>4</sub>	EMIOS <sub>12</sub>	EMIOS <sub>21</sub>	VDD33	VSS	VRC <sub>CTL</sub>	PLL <sub>CFG1</sub>	EXTAL	N
P	ETPUA <sub>3</sub>	ETPUA <sub>2</sub>	VSS	VDD	GPIO <sub>207</sub>	VDDE2	EMIOS <sub>6</sub>	EMIOS <sub>8</sub>	EMIOS <sub>16</sub>	EMIOS <sub>17</sub>	EMIOS <sub>22</sub>	CNTXA	VDD	VSS	VRC33	XTAL	P
R	CS0	VSS	VDD	GPIO <sub>206</sub>	EMIOS <sub>4</sub>	EMIOS <sub>3</sub>	EMIOS <sub>9</sub>	EMIOS <sub>11</sub>	EMIOS <sub>14</sub>	EMIOS <sub>19</sub>	EMIOS <sub>23</sub>	CNRXA	CNRXB	VDD	VSS	VDD <sub>SYN</sub>	R
T	VSS	VDD	OE	EMIOS <sub>0</sub>	EMIOS <sub>1</sub>	EMIOS <sub>5</sub>	EMIOS <sub>7</sub>	EMIOS <sub>13</sub>	EMIOS <sub>15</sub>	EMIOS <sub>18</sub>	EMIOS <sub>20</sub>	CNTXB	VDDE5	ENG <sub>CLK</sub>	VDD	VSS	T

Figure 24. MPC5533 208 Package

## 4.2 MPC5533 324 PBGA Pinout

Figure 25 is a pinout for the MPC5533 324 PBGA package.

### NOTE

The MPC5500 devices are pin compatible for software portability and use the primary function names to label the pins in the BGA diagram. Although some devices do not support all the primary functions shown in the BGA diagram, the muxed and GPIO signals on those pins remain available. See the signals chapter in the device reference manual for the signal muxing.

	1	2	3	4	5	6	7	8	9	10	11	12	13	14	15	16	17	18	19	20	21	22
A	VSS	VDD	VSTBY	AN37	AN11	VDDA1	VSSA1	AN1	AN5	VRH	VRL	AN27	AN28	AN35	VSSA0	AN12	MDO11	MDO10	MDO8	VDD	VDD33	VSS
B	VDD33	VSS	VDD	AN36	AN39	AN19	AN16	AN0	AN4	REF BYPC	AN23	AN26	AN31	AN32	VSSA0	AN13	MDO9	MDO7	MDO4	MDO0	VSS	VDDE7
C	ETPUA 30	ETPUA 31	VSS	VDD	AN8	AN17	AN20	AN21	AN3	AN7	AN22	AN25	AN30	AN33	VDDA0	AN14	MDO5	MDO2	MDO1	VSS	VDDE7	VDD
D	ETPUA 28	ETPUA 29	ETPUA 26	VSS	VDD	AN38	AN9	AN10	AN18	AN2	AN6	AN24	AN29	AN34	VDDEH 9	AN15	MDO6	MDO3	VSS	VDDE7	TCK	TDI
E	ETPUA 24	ETPUA 27	ETPUA 25	ETPUA 21																VDDE7	TMS	TDO
F	ETPUA 23	ETPUA 22	ETPUA 17	ETPUA 18																VDDE7	JCOMP	EVTI
G	ETPUA 20	ETPUA 19	ETPUA 14	ETPUA 13																RDY	MCKO	MSE00
H	ETPUA 16	ETPUA 15	ETPUA 10	VDDEH 1																VDDEH 10	GPIO 203	GPIO 204
J	ETPUA 12	ETPUA 11	ETPUA 6	ETPUA 9					VSS	VSS	VSS	VSS	VSS	VDDE7					SOUTB	PCSB3	PCSB0	
K	ETPUA 8	ETPUA 7	ETPUA 2	ETPUA 5					VSS	VSS	VSS	VSS	VSS	VSS					PCSA3	PCSB4	SCKB	
L	ETPUA 4	ETPUA 3	ETPUA 0	ETPUA 1					VSS	VSS	VSS	VSS	VSS	VSS					PCSB5	SOUTA	SINA	
M	BDIP	TCRCLK A	CS1	CS0					VDDE2	VDDE2	VSS	VSS	VSS	VSS					PCSA1	PCSA0	PCSA2	
N	CS3	CS2	WE1	WE0					VSS	VSS	VDDE2	VSS	VSS	VSS					PCSA4	TXDA	PCSA5	
P	ADDR 16	ADDR 17	RD_WR	VDD33					VSS	VSS	VDDE2	VSS	VSS	VSS					CNTXC	RXDA	RSTOUT	
R	ADDR 18	ADDR 19	VDDE2	TA					VSS	VSS	VDDE2	VSS	VSS	VSS					WKP CFG	CNRXC	TXDB	
T	ADDR 20	ADDR 21	ADDR 12	TS															RXDB	BOOT CFG1	VRC VSS	
U	ADDR 22	ADDR 23	ADDR 13	ADDR 14															VDDEH 6	PLL CFG1	BOOT CFG0	
V	ADDR 24	ADDR 25	ADDR 15	ADDR 31															VDD	VRC CTL	PLL CFG0	
W	ADDR 26	VDDE2	ADDR 30	VSS	VDD	VDDE2	VDD33	VDDE2	DATA 11	DATA 12	DATA 14	EMIOS 2	EMIOS 8	VDDEH 4	EMIOS 12	EMIOS 21	VDDE5	NC	VSS	VDD		
Y	ADDR 28	ADDR 27	VSS	VDD	VDDE2	DATA 8	DATA 9	DATA 10	GPIO 207	DATA 13	DATA 15	EMIOS 6	EMIOS 10	EMIOS 15	EMIOS 17	EMIOS 22	CNTXA	VDDE5	NC	VSS		
AA	ADDR 29	VSS	VDD	VDDE2	DATA 1	VDDE2	GPIO 206	DATA 5	DATA 7	VDDE2	EMIOS 3	EMIOS 5	EMIOS 9	EMIOS 13	EMIOS 16	EMIOS 19	EMIOS 23	CNRXA	VDDE5	CLKOUT		
AB	VSS	VDD	VDDE2	DATA 0	DATA 2	DATA 3	DATA 4	DATA 6	OE	EMIOS 0	EMIOS 1	EMIOS 4	EMIOS 7	EMIOS 11	EMIOS 14	EMIOS 18	EMIOS 20	CNTXB	CNRXB	VDDE5		
	1	2	3	4	5	6	7	8	9	10	11	12	13	14	15	16	17	18	19	20	21	22

Note: NC No connect. Reserved (W18 & Y19 are shorted to each other)

Figure 25. MPC5533 324 Package

### 4.3 MPC5533 208-Pin Package Dimensions

The package drawings of the MPC5533 208-pin MAP BGA are shown in Figure 26.

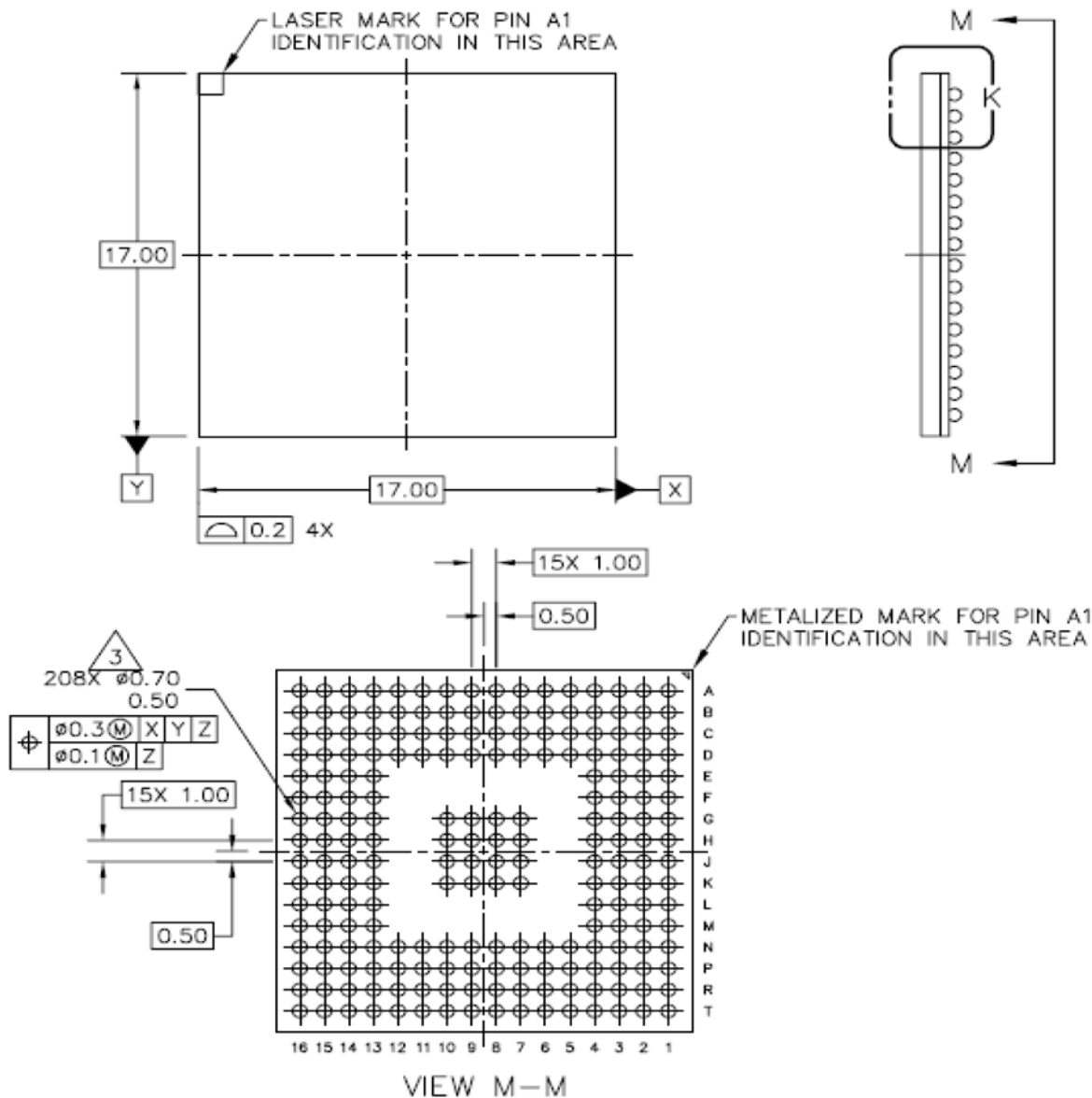

© FREESCALE SEMICONDUCTOR, INC. ALL RIGHTS RESERVED.		<b>MECHANICAL OUTLINE</b>		PRINT VERSION NOT TO SCALE	
TITLE: 208 I/O MAP BGA, 17 X 17 PKG, 1-MM PITCH		DOCUMENT NO: 98ARS23882W		REV: D	
		CASE NUMBER: 1159A-01		02 AUG 2005	
		STANDARD: JEDEC MO-151 AAF-1			

Figure 26. MPC5533 208-Pin Package

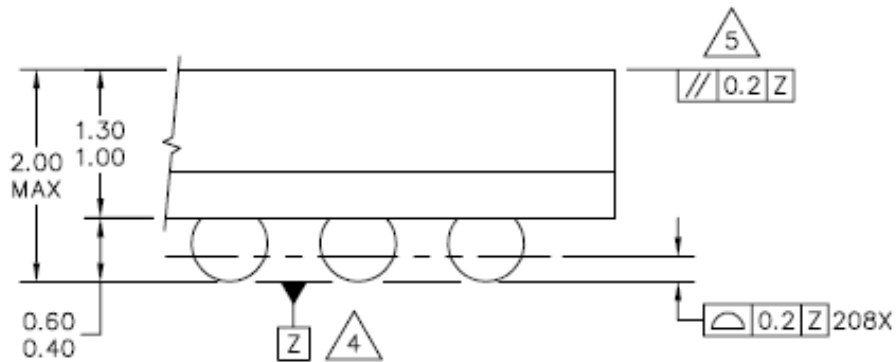

DETAIL K  
(ROTATED 90° CLOCKWISE)

NOTES:

1. ALL DIMENSIONS ARE IN MILLIMETERS.
2. INTERPRET DIMENSIONS AND TOLERANCES PER ASME Y14.5M-1994.
3. DIMENSION b IS MEASURED AT THE MAXIMUM SOLDER BALL DIAMETER, PARALLEL TO DATUM PLANE Z.
4. DATUM Z (SEATING PLANE) IS DEFINED BY THE SPHERICAL CROWNS OF THE SOLDER BALLS.
5. PARALLELISM MEASUREMENT SHALL EXCLUDE ANY EFFECT OF MARK ON TOP SURFACE OF PACKAGE.

© FREESCALE SEMICONDUCTOR, INC. ALL RIGHTS RESERVED.	<b>MECHANICAL OUTLINE</b>	PRINT VERSION NOT TO SCALE	
TITLE: 208 I/O MAP BGA, 17 X 17 PKG, 1-MM PITCH	DOCUMENT NO: 98ARS23882W	REV: D	
	CASE NUMBER: 1159A-01	02 AUG 2005	
	STANDARD: JEDEC MO-151 AAF-1		

Figure 26. MPC5533 208 MAP BGA Package (continued)

### 4.4 MPC5533 324-Pin Package Dimensions

The package drawings of the MPC5533 324-pin TEPBGA package are shown in Figure 27.

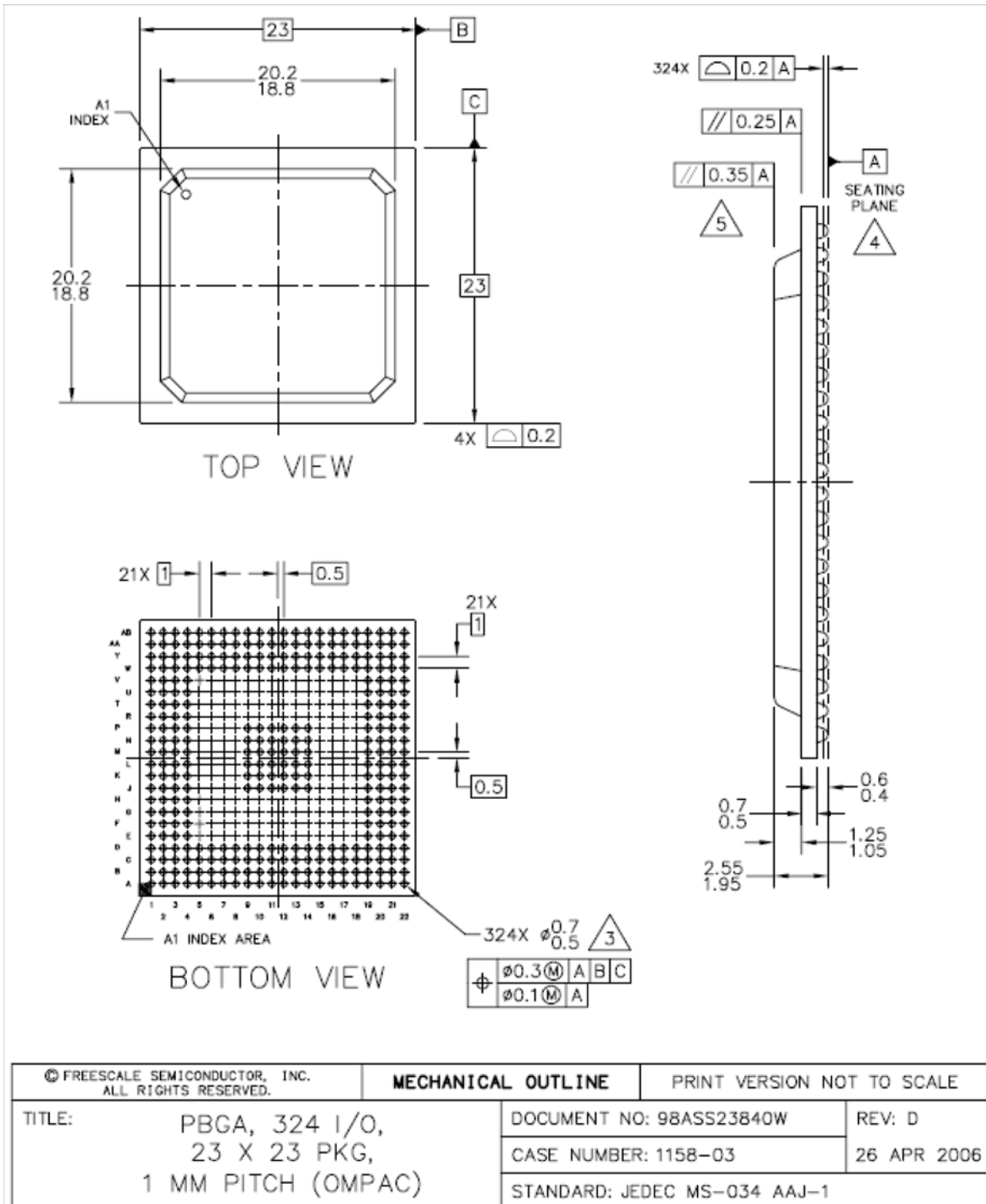

Figure 27. MPC5533 324 TEPBGA Package

NOTES:

1. ALL DIMENSIONS IN MILLIMETERS.
2. DIMENSIONING AND TOLERANCING PER ASME Y14.5M-1994.
3. MAXIMUM SOLDER BALL DIAMETER MEASURED PARALLEL TO DATUM A.
4. DATUM A, THE SEATING PLANE, IS DETERMINED BY THE SPHERICAL CROWNS OF THE SOLDER BALLS.
5. PARALLELISM MEASUREMENT SHALL EXCLUDE ANY EFFECT OF MARK ON TOP SURFACE OF PACKAGE.

© FREESCALE SEMICONDUCTOR, INC. ALL RIGHTS RESERVED.		<b>MECHANICAL OUTLINE</b>		PRINT VERSION NOT TO SCALE	
TITLE:	PBGA, 324 I/O, 23 X 23 PKG, 1 MM PITCH (OMPAC)	DOCUMENT NO: 98ASS23840W		REV: D	
		CASE NUMBER: 1158-03		26 APR 2006	
		STANDARD: JEDEC MS-034 AAJ-1			

**Figure 27. MPC5533 324 TEPBGA Package (continued)**



## 5 Revision History for the MPC5533 Data Sheet

Table 27 provides a revision history of the MPC5533 Data Sheet.

**Table 27. Revision History for the MPC5533 Data Sheet**

Substantive Change(s)	Version
Initial version for MPC5533.	Rev. 0.0

## **How to Reach Us:**

**Home Page:**  
www.freescale.com

**E-mail:**  
support@freescale.com

**USA/Europe or Locations Not Listed:**  
Freescale Semiconductor  
Technical Information Center, CH370  
1300 N. Alma School Road  
Chandler, Arizona 85224  
+1-800-521-6274 or +1-480-768-2130  
support@freescale.com

**Europe, Middle East, and Africa:**  
Freescale Halbleiter Deutschland GmbH  
Technical Information Center  
Schatzbogen 7  
81829 Muenchen, Germany  
+44 1296 380 456 (English)  
+46 8 52200080 (English)  
+49 89 92103 559 (German)  
+33 1 69 35 48 48 (French)  
support@freescale.com

**Japan:**  
Freescale Semiconductor Japan Ltd.  
Headquarters  
ARCO Tower 15F  
1-8-1, Shimo-Meguro, Meguro-ku,  
Tokyo 153-0064  
Japan  
0120 191014 or +81 3 5437 9125  
support.japan@freescale.com

**Asia/Pacific:**  
Freescale Semiconductor Hong Kong Ltd.  
Technical Information Center  
2 Dai King Street  
Tai Po Industrial Estate  
Tai Po, N.T., Hong Kong  
+800 2666 8080  
support.asia@freescale.com

**For Literature Requests Only:**  
Freescale Semiconductor Literature Distribution Center  
P.O. Box 5405  
Denver, Colorado 80217  
1-800-441-2447 or 303-675-2140  
Fax: 303-675-2150  
LDCForFreescaleSemiconductor@hibbertgroup.com

Information in this document is provided solely to enable system and software implementers to use Freescale Semiconductor products. There are no express or implied copyright licenses granted hereunder to design or fabricate any integrated circuits or integrated circuits based on the information in this document.

Freescale Semiconductor reserves the right to make changes without further notice to any products herein. Freescale Semiconductor makes no warranty, representation or guarantee regarding the suitability of its products for any particular purpose, nor does Freescale Semiconductor assume any liability arising out of the application or use of any product or circuit, and specifically disclaims any and all liability, including without limitation consequential or incidental damages. "Typical" parameters that may be provided in Freescale Semiconductor data sheets and/or specifications can and do vary in different applications and actual performance may vary over time. All operating parameters, including "Typicals", must be validated for each customer application by customer's technical experts. Freescale Semiconductor does not convey any license under its patent rights nor the rights of others. Freescale Semiconductor products are not designed, intended, or authorized for use as components in systems intended for surgical implant into the body, or other applications intended to support or sustain life, or for any other application in which the failure of the Freescale Semiconductor product could create a situation where personal injury or death may occur. Should Buyer purchase or use Freescale Semiconductor products for any such unintended or unauthorized application, Buyer shall indemnify and hold Freescale Semiconductor and its officers, employees, subsidiaries, affiliates, and distributors harmless against all claims, costs, damages, and expenses, and reasonable attorney fees arising out of, directly or indirectly, any claim of personal injury or death associated with such unintended or unauthorized use, even if such claim alleges that Freescale Semiconductor was negligent regarding the design or manufacture of the part.

Freescale™ and the Freescale logo are trademarks of Freescale Semiconductor, Inc. All other product or service names are the property of their respective owners.

© Freescale Semiconductor, Inc. 2008. All rights reserved.

RoHS-compliant and/or Pb-free versions of Freescale products have the functionality and electrical characteristics as their non-RoHS-compliant and/or non-Pb-free counterparts. For further information, see <http://www.freescale.com> or contact your Freescale sales representative.

For information on Freescale's Environmental Products program, go to <http://www.freescale.com/epp>.

Document Number: MPC5533  
Rev. 0.0  
10 Oct 2008

