

ALUMINUM ELECTROLYTIC CAPACITORS

LS

Snap-in Terminal Type, 85°C Standard
series



Anti-Solvent
Feature
(Through
100V only)

- Withstanding 3000 hours application of rated ripple current at 85°C.
- Compliant to the RoHS directive (2002/95/EC).

LS

Smaller

LG

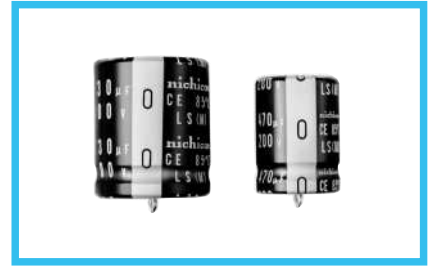

Specifications

Item	Performance Characteristics																
Category Temperature Range	- 40 to +85°C (16 to 250V), - 25 to +85°C (350 to 450V)																
Rated Voltage Range	16 to 450V																
Rated Capacitance Range	56 to 56000μF																
Capacitance Tolerance	± 20% at 120Hz, 20°C																
Leakage Current	$I \leq 3\sqrt{CV}$ (μA) (After 5 minutes' application of rated voltage) [C : Rated Capacitance (μF) V : Voltage (V)]																
Tangent of loss angle (tan δ)	Measurement frequency : 120Hz at 20°C																
	Rated voltage (V)	16	25	35	50	63	80	100	160	180	200	250	350	400	450		
	tan δ (MAX.)	0.50	0.40	0.35	0.30	0.25	0.20	0.20	0.15	0.15	0.15	0.15	0.15	0.15	0.20		
Stability at Low Temperature	Measurement frequency : 120Hz																
	Rated voltage (V)		16 to 100			160 to 250			350 to 450								
	Impedance ratio ZT/Z20(MAX.)	Z - 25°C/Z+20°C	4			3			8								
	Z - 40°C/Z+20°C	20			12			—									
Endurance	The specifications listed at right shall be met when the capacitors are restored to 20°C after D.C. bias plus rated ripple current is applied for 3000 hours at 85°C, the peak voltage shall not exceed the rated voltage.																
	Capacitance change	Within ±20% of the initial capacitance value															
	tan δ	200% or less than the initial specified value															
Shelf Life	After storing the capacitors under no load at 85°C for 1000 hours and then performing voltage treatment based on JIS C 5101-4 clause 4.1 at 20°C, they shall meet the requirements listed at right.																
	Capacitance change	Within ±15% of the initial capacitance value															
	tan δ	150% or less than the initial specified value															
Leakage current	Less than or equal to the initial specified value																
Marking	Printed with white color letter on black sleeve.																

Drawing

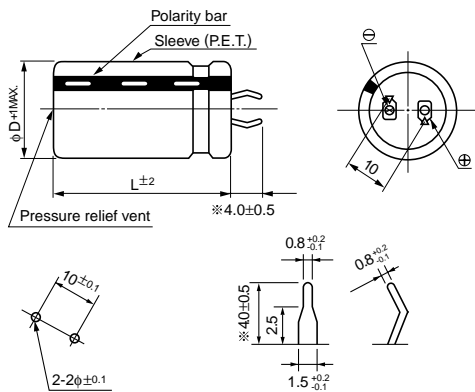

(PC board hole dimensions)

(Terminal dimensions)

※ The other terminal is also available upon request.
Please refer to page 280 for schematic of dimensions.

Type numbering system (Example : 200V 390μF)

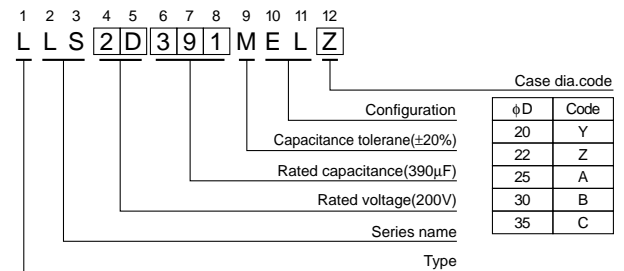

Frequency coefficient of rated ripple current

Frequency (Hz)	50	60	120	300	1 k	10k	50k or more
16 to 100V	0.88	0.90	1.00	1.07	1.15	1.15	1.15
160 to 250V	0.81	0.85	1.00	1.17	1.32	1.45	1.50
350 to 450V	0.77	0.82	1.00	1.16	1.30	1.41	1.43

Minimum order quantity : 50pcs.

● Dimension table in next page.

■Dimensions

16V (1C)				
Cap. (μF)	Size φD × L(mm)	Rated ripple (mA)	Leakage Current (mA)	Code
8200	22 × 25	2560	1.08	LLS1C822MELZ
10000	22 × 30	2890	1.20	LLS1C103MELZ
12000	22 × 30	3130	1.31	LLS1C123MELZ
	25 × 25	3010	1.31	LLS1C123MELA
15000	22 × 35	3690	1.46	LLS1C153MELZ
	25 × 30	3640	1.46	LLS1C153MELA
	30 × 25	3730	1.46	LLS1C153MELB
18000	22 × 40	3980	1.60	LLS1C183MELZ
	25 × 35	3980	1.60	LLS1C183MELA
	30 × 30	3880	1.60	LLS1C183MELB
22000	22 × 50	4520	1.77	LLS1C223MELZ
	25 × 40	4440	1.77	LLS1C223MELA
	30 × 30	4380	1.77	LLS1C223MELB
27000	25 × 45	4980	1.97	LLS1C273MELA
	30 × 35	4950	1.97	LLS1C273MELB
	35 × 30	4820	1.97	LLS1C273MELC
33000	25 × 50	5490	2.17	LLS1C333MELA
	30 × 40	5600	2.17	LLS1C333MELB
	35 × 30	5460	2.17	LLS1C333MELC
39000	30 × 45	6210	2.36	LLS1C393MELB
	35 × 35	6120	2.36	LLS1C393MELC
47000	30 × 50	6930	2.60	LLS1C473MELB
	35 × 40	6890	2.60	LLS1C473MELC
56000	35 × 45	7690	2.83	LLS1C563MELC

25V (1E)				
Cap. (μF)	Size φD × L(mm)	Rated ripple (mA)	Leakage Current (mA)	Code
5600	22 × 25	2310	1.12	LLS1E562MELZ
6800	22 × 30	2560	1.23	LLS1E682MELZ
	25 × 25	2470	1.23	LLS1E682MELA
8200	22 × 35	2860	1.35	LLS1E822MELZ
	25 × 25	2780	1.35	LLS1E822MELA
10000	22 × 35	3310	1.50	LLS1E103MELZ
	25 × 30	3160	1.50	LLS1E103MELA
12000	22 × 40	3770	1.64	LLS1E123MELZ
	25 × 35	3630	1.64	LLS1E123MELA
	30 × 25	3800	1.64	LLS1E123MELB
15000	22 × 50	4210	1.83	LLS1E153MELZ
	25 × 40	4100	1.83	LLS1E153MELA
	30 × 30	4000	1.83	LLS1E153MELB
18000	25 × 45	4680	2.01	LLS1E183MELA
	30 × 35	4660	2.01	LLS1E183MELB
	35 × 30	4680	2.01	LLS1E183MELC
22000	25 × 50	5190	2.22	LLS1E223MELA
	30 × 40	5330	2.22	LLS1E223MELB
	35 × 35	5260	2.22	LLS1E223MELC
27000	30 × 45	6020	2.46	LLS1E273MELB
	35 × 40	6020	2.46	LLS1E273MELC
33000	35 × 45	6750	2.72	LLS1E333MELC
39000	35 × 50	7560	2.96	LLS1E393MELC

35V (1V)				
Cap. (μF)	Size φD × L(mm)	Rated ripple (mA)	Leakage Current (mA)	Code
3900	22 × 25	2220	1.10	LLS1V392MELZ
4700	22 × 30	2460	1.21	LLS1V472MELZ
	25 × 25	2430	1.21	LLS1V472MELA
5600	22 × 35	2790	1.32	LLS1V562MELZ
	25 × 30	2750	1.32	LLS1V562MELA
6800	22 × 40	2970	1.46	LLS1V682MELZ
	25 × 30	2890	1.46	LLS1V682MELA
	30 × 25	3090	1.46	LLS1V682MELB
8200	22 × 45	3470	1.60	LLS1V822MELZ
	25 × 35	3330	1.60	LLS1V822MELA
	30 × 30	3290	1.60	LLS1V822MELB
10000	22 × 50	3750	1.77	LLS1V103MELZ
	25 × 40	3650	1.77	LLS1V103MELA
	30 × 30	3610	1.77	LLS1V103MELB
12000	25 × 45	4150	1.94	LLS1V123MELA
	30 × 35	4140	1.94	LLS1V123MELB
	35 × 30	4270	1.94	LLS1V123MELC
15000	25 × 50	4800	2.17	LLS1V153MELA
	30 × 40	4800	2.17	LLS1V153MELB
	35 × 35	4950	2.17	LLS1V153MELC
18000	30 × 45	5300	2.38	LLS1V183MELB
	35 × 40	5710	2.38	LLS1V183MELC
22000	35 × 45	6380	2.63	LLS1V223MELC
27000	35 × 50	6900	2.91	LLS1V273MELC

50V (1H)				
Cap. (μF)	Size φD × L(mm)	Rated ripple (mA)	Leakage Current (mA)	Code
2200	22 × 25	1930	0.99	LLS1H222MELZ
2700	22 × 30	2210	1.10	LLS1H272MELZ
3300	22 × 30	2410	1.21	LLS1H332MELZ
	25 × 25	2380	1.21	LLS1H332MELA
3900	22 × 35	2720	1.32	LLS1H392MELZ
	25 × 30	2680	1.32	LLS1H392MELA
4700	22 × 40	3020	1.45	LLS1H472MELZ
	25 × 30	3070	1.45	LLS1H472MELA
	30 × 25	3010	1.45	LLS1H472MELB
5600	22 × 45	3430	1.58	LLS1H562MELZ
	25 × 35	3470	1.58	LLS1H562MELA
	30 × 30	3430	1.58	LLS1H562MELB
6800	22 × 50	3940	1.74	LLS1H682MELZ
	25 × 40	3870	1.74	LLS1H682MELA
	30 × 35	3930	1.74	LLS1H682MELB
8200	25 × 45	4440	1.92	LLS1H822MELA
	30 × 35	4470	1.92	LLS1H822MELB
	35 × 30	4410	1.92	LLS1H822MELC
10000	30 × 40	5080	2.12	LLS1H103MELB
	35 × 35	4920	2.12	LLS1H103MELC
12000	30 × 50	5720	2.32	LLS1H123MELB
	35 × 40	5690	2.32	LLS1H123MELC
15000	35 × 45	6560	2.59	LLS1H153MELC
18000	35 × 50	7140	2.84	LLS1H183MELC

Rated ripple current (mA Arms) at 85°C 120Hz

■Dimensions

63V (1J)				
Cap. (μF)	Size φD × L(mm)	Rated ripple (mA)	Leakage Current (mA)	Code
1800	22 × 25	1900	1.01	LLS1J182MELZ
	22 × 30	2350	1.11	LLS1J222MELZ
2200	25 × 25	2300	1.11	LLS1J222MELA
	22 × 35	2500	1.23	LLS1J272MELZ
2700	25 × 30	2520	1.23	LLS1J272MELA
	22 × 35	2720	1.36	LLS1J332MELZ
3300	25 × 30	2740	1.36	LLS1J332MELA
	30 × 25	2840	1.36	LLS1J332MELB
	22 × 40	3090	1.48	LLS1J392MELZ
3900	25 × 35	3130	1.48	LLS1J392MELA
	30 × 30	3090	1.48	LLS1J392MELB
	22 × 50	3690	1.63	LLS1J472MELZ
4700	25 × 40	3590	1.63	LLS1J472MELA
	30 × 30	3540	1.63	LLS1J472MELB
	25 × 45	4010	1.78	LLS1J562MELA
5600	30 × 35	4000	1.78	LLS1J562MELB
	35 × 30	3750	1.78	LLS1J562MELC
	25 × 50	4520	1.96	LLS1J682MELA
6800	30 × 40	4550	1.96	LLS1J682MELB
	35 × 30	4440	1.96	LLS1J682MELC
	30 × 45	5120	2.15	LLS1J822MELB
8200	35 × 35	5050	2.15	LLS1J822MELC
	30 × 50	5780	2.38	LLS1J103MELB
10000	35 × 40	5750	2.38	LLS1J103MELC
	35 × 45	6470	2.60	LLS1J123MELC

80V (1K)				
Cap. (μF)	Size φD × L(mm)	Rated ripple (mA)	Leakage Current (mA)	Code
1200	22 × 25	1770	0.92	LLS1K122MELZ
1500	22 × 30	2010	1.03	LLS1K152MELZ
	22 × 30	2110	1.13	LLS1K182MELZ
1800	25 × 25	2260	1.13	LLS1K182MELA
	22 × 35	2530	1.25	LLS1K222MELZ
2200	25 × 30	2530	1.25	LLS1K222MELA
	30 × 25	2560	1.25	LLS1K222MELB
	22 × 40	2930	1.39	LLS1K272MELZ
2700	25 × 35	2930	1.39	LLS1K272MELA
	30 × 30	2910	1.39	LLS1K272MELB
	22 × 45	3230	1.54	LLS1K332MELZ
3300	25 × 40	3290	1.54	LLS1K332MELA
	30 × 30	3250	1.54	LLS1K332MELB
	22 × 50	3620	1.67	LLS1K392MELZ
3900	25 × 45	3710	1.67	LLS1K392MELA
	30 × 35	3700	1.67	LLS1K392MELB
	25 × 50	4280	1.83	LLS1K472MELA
4700	30 × 40	4230	1.83	LLS1K472MELB
	35 × 30	4120	1.83	LLS1K472MELC
	30 × 45	4700	2.00	LLS1K562MELB
5600	35 × 35	4640	2.00	LLS1K562MELC
	30 × 50	5270	2.21	LLS1K682MELB
6800	35 × 40	5240	2.21	LLS1K682MELC
	35 × 45	5890	2.42	LLS1K822MELC
10000	35 × 50	6630	2.68	LLS1K103MELC

100V (2A)				
Cap. (μF)	Size φD × L(mm)	Rated ripple (mA)	Leakage Current (mA)	Code
820	22 × 25	1860	0.85	LLS2A821MELZ
1000	22 × 30	2020	0.94	LLS2A102MELZ
1200	22 × 30	2120	1.03	LLS2A122MELZ
	25 × 25	2110	1.03	LLS2A122MELA
1500	22 × 35	2450	1.16	LLS2A152MELZ
	25 × 30	2470	1.16	LLS2A152MELA
	30 × 25	2560	1.16	LLS2A152MELB
1800	22 × 40	2770	1.27	LLS2A182MELZ
	25 × 35	2810	1.27	LLS2A182MELA
	30 × 25	2650	1.27	LLS2A182MELB
2200	22 × 45	3150	1.40	LLS2A222MELZ
	25 × 40	3210	1.40	LLS2A222MELA
	30 × 30	3170	1.40	LLS2A222MELB
2700	25 × 45	3660	1.55	LLS2A272MELA
	30 × 35	3650	1.55	LLS2A272MELB
	35 × 30	3770	1.55	LLS2A272MELC
3300	25 × 50	4150	1.72	LLS2A332MELA
	30 × 40	4180	1.72	LLS2A332MELB
	35 × 35	4070	1.72	LLS2A332MELC
3900	30 × 45	4670	1.87	LLS2A392MELB
	35 × 35	4610	1.87	LLS2A392MELC
4700	30 × 50	5260	2.05	LLS2A472MELB
	35 × 40	5230	2.05	LLS2A472MELC
5600	35 × 45	5880	2.24	LLS2A562MELC
6800	35 × 50	6010	2.47	LLS2A682MELC

Rated ripple current (mArms) at 85° C 120Hz

■Dimensions

160V (2C)				
Cap. (μF)	Size φD × L(mm)	Rated ripple (mA)	Leakage Current (mA)	Code
270	20 × 25	1280	0.62	LLS2C271MELY
330	20 × 25	1550	0.68	LLS2C331MELY
390	20 × 30	1630	0.74	LLS2C391MELY
	22 × 25	1630	0.74	LLS2C391MELZ
470	20 × 30	1900	0.82	LLS2C471MELY
	22 × 30	1860	0.82	LLS2C471MELZ
	25 × 25	1860	0.82	LLS2C471MELA
560	20 × 35	2140	0.89	LLS2C561MELY
	22 × 30	2150	0.89	LLS2C561MELZ
	25 × 25	2150	0.89	LLS2C561MELA
680	20 × 40	2350	0.98	LLS2C681MELY
	22 × 35	2350	0.98	LLS2C681MELZ
	25 × 30	2330	0.98	LLS2C681MELA
	30 × 25	2330	0.98	LLS2C681MELB
820	22 × 40	2680	1.08	LLS2C821MELZ
	25 × 30	2650	1.08	LLS2C821MELA
	30 × 25	2640	1.08	LLS2C821MELB
1000	22 × 45	3020	1.20	LLS2C102MELZ
	25 × 35	3000	1.20	LLS2C102MELA
	30 × 30	2960	1.20	LLS2C102MELB
1200	25 × 40	3430	1.31	LLS2C122MELA
	30 × 30	3410	1.31	LLS2C122MELB
	35 × 25	3400	1.31	LLS2C122MELC
1500	25 × 50	3960	1.46	LLS2C152MELA
	30 × 35	3960	1.46	LLS2C152MELB
	35 × 30	3940	1.46	LLS2C152MELC
1800	30 × 40	4310	1.60	LLS2C182MELB
	35 × 35	4280	1.60	LLS2C182MELC
2200	30 × 50	4960	1.77	LLS2C222MELB
	35 × 40	4960	1.77	LLS2C222MELC
2700	35 × 45	5570	1.97	LLS2C272MELC

180V (2Z)				
Cap. (μF)	Size φD × L(mm)	Rated ripple (mA)	Leakage Current (mA)	Code
270	20 × 25	1290	0.66	LLS2Z271MELY
330	20 × 30	1770	0.73	LLS2Z331MELY
	22 × 25	1770	0.73	LLS2Z331MELZ
390	20 × 30	1840	0.79	LLS2Z391MELY
	22 × 25	1840	0.79	LLS2Z391MELZ
470	20 × 35	1910	0.87	LLS2Z471MELY
	22 × 30	1910	0.87	LLS2Z471MELZ
	25 × 25	2080	0.87	LLS2Z471MELA
560	20 × 40	2150	0.95	LLS2Z561MELY
	22 × 35	2250	0.95	LLS2Z561MELZ
	25 × 25	2150	0.95	LLS2Z561MELA
	22 × 35	2480	1.04	LLS2Z681MELZ
680	25 × 30	2500	1.04	LLS2Z681MELA
	30 × 25	2460	1.04	LLS2Z681MELB
	22 × 40	2860	1.15	LLS2Z821MELZ
820	25 × 35	2750	1.15	LLS2Z821MELA
	30 × 25	2690	1.15	LLS2Z821MELB
	22 × 50	3100	1.27	LLS2Z102MELZ
1000	25 × 40	3060	1.27	LLS2Z102MELA
	30 × 30	3100	1.27	LLS2Z102MELB
	25 × 45	3630	1.39	LLS2Z122MELA
1200	30 × 35	3550	1.39	LLS2Z122MELB
	35 × 30	3490	1.39	LLS2Z122MELC
	30 × 40	4100	1.55	LLS2Z152MELB
1500	35 × 35	4020	1.55	LLS2Z152MELC
	30 × 45	4550	1.70	LLS2Z182MELB
1800	35 × 35	4540	1.70	LLS2Z182MELC
	2200	35 × 40	4830	1.88
2700	35 × 50	5300	2.09	LLS2Z272MELC

200V (2D)				
Cap. (μF)	Size φD × L(mm)	Rated ripple (mA)	Leakage Current (mA)	Code
220	20 × 25	1190	0.62	LLS2D221MELY
270	20 × 25	1390	0.69	LLS2D271MELY
	22 × 25	1370	0.69	LLS2D271MELZ
330	20 × 30	1560	0.77	LLS2D331MELY
	22 × 25	1510	0.77	LLS2D331MELZ
390	20 × 35	1740	0.83	LLS2D391MELY
	22 × 30	1730	0.83	LLS2D391MELZ
	25 × 25	1710	0.83	LLS2D391MELA
470	20 × 35	2030	0.91	LLS2D471MELY
	22 × 30	1970	0.91	LLS2D471MELZ
	25 × 25	1950	0.91	LLS2D471MELA
560	20 × 40	2180	1.00	LLS2D561MELY
	22 × 35	2180	1.00	LLS2D561MELZ
	25 × 30	2150	1.00	LLS2D561MELA
	30 × 25	2150	1.00	LLS2D561MELB
680	22 × 40	2480	1.10	LLS2D681MELZ
	25 × 30	2480	1.10	LLS2D681MELA
	30 × 25	2480	1.10	LLS2D681MELB
820	22 × 45	2810	1.21	LLS2D821MELZ
	25 × 35	2790	1.21	LLS2D821MELA
	30 × 30	2800	1.21	LLS2D821MELB
1000	22 × 50	3280	1.34	LLS2D102MELZ
	25 × 40	3280	1.34	LLS2D102MELA
	30 × 35	3150	1.34	LLS2D102MELB
1200	30 × 35	3610	1.46	LLS2D122MELB
	35 × 30	3570	1.46	LLS2D122MELC
1500	30 × 45	4130	1.64	LLS2D152MELB
	35 × 35	4060	1.64	LLS2D152MELC
1800	30 × 50	4600	1.80	LLS2D182MELB
	35 × 40	4590	1.80	LLS2D182MELC
2200	35 × 45	5250	1.98	LLS2D222MELC

250V (2E)				
Cap. (μF)	Size φD × L(mm)	Rated ripple (mA)	Leakage Current (mA)	Code
180	20 × 25	1200	0.63	LLS2E181MELY
220	20 × 25	1260	0.70	LLS2E221MELY
	22 × 25	1240	0.70	LLS2E221MELZ
270	20 × 30	1420	0.77	LLS2E271MELY
	22 × 25	1500	0.77	LLS2E271MELZ
330	20 × 35	1680	0.86	LLS2E331MELY
	22 × 30	1660	0.86	LLS2E331MELZ
	25 × 25	1610	0.86	LLS2E331MELA
390	20 × 40	1920	0.93	LLS2E391MELY
	22 × 35	1880	0.93	LLS2E391MELZ
	25 × 30	1880	0.93	LLS2E391MELA
470	22 × 35	2150	1.02	LLS2E471MELZ
	25 × 35	2150	1.02	LLS2E471MELA
	30 × 25	2040	1.02	LLS2E471MELB
560	22 × 40	2480	1.12	LLS2E561MELZ
	25 × 35	2350	1.12	LLS2E561MELA
	30 × 25	2350	1.12	LLS2E561MELB
680	25 × 40	2670	1.23	LLS2E681MELA
	30 × 30	2710	1.23	LLS2E681MELB
820	25 × 45	3010	1.35	LLS2E821MELA
	30 × 35	2980	1.35	LLS2E821MELB
	35 × 30	2960	1.35	LLS2E821MELC
1000	30 × 40	3560	1.50	LLS2E102MELB
	35 × 35	3480	1.50	LLS2E102MELC
1200	30 × 45	3990	1.64	LLS2E122MELB
	35 × 35	3840	1.64	LLS2E122MELC
1500	35 × 40	4330	1.83	LLS2E152MELC
1800	35 × 50	4540	2.01	LLS2E182MELC

Rated ripple current (mArms) at 85° C 120Hz

■Dimensions

350V (2V)				
Cap. (μF)	Size φD × L(mm)	Rated ripple (mA)	Leakage Current (mA)	Code
120	20 × 30	960	0.61	LLS2V121MELY
	22 × 25	1040	0.61	LLS2V121MELZ
150	20 × 30	1100	0.68	LLS2V151MELY
	22 × 30	1200	0.68	LLS2V151MELZ
	25 × 25	1220	0.68	LLS2V151MELA
180	20 × 35	1240	0.75	LLS2V181MELY
	22 × 30	1340	0.75	LLS2V181MELZ
	25 × 25	1370	0.75	LLS2V181MELA
220	22 × 35	1470	0.83	LLS2V221MELZ
	25 × 30	1530	0.83	LLS2V221MELA
	30 × 25	1540	0.83	LLS2V221MELB
270	22 × 40	1700	0.92	LLS2V271MELZ
	25 × 35	1730	0.92	LLS2V271MELA
	30 × 25	1800	0.92	LLS2V271MELB
330	22 × 45	1870	1.01	LLS2V331MELZ
	25 × 35	1970	1.01	LLS2V331MELA
	30 × 30	2030	1.01	LLS2V331MELB
390	25 × 40	2140	1.10	LLS2V391MELA
	30 × 35	2230	1.10	LLS2V391MELB
	35 × 30	2300	1.10	LLS2V391MELC
470	25 × 50	2550	1.21	LLS2V471MELA
	30 × 35	2530	1.21	LLS2V471MELB
	35 × 30	2550	1.21	LLS2V471MELC
560	30 × 40	2730	1.32	LLS2V561MELB
	35 × 35	2750	1.32	LLS2V561MELC
680	30 × 50	3150	1.46	LLS2V681MELB
	35 × 40	3150	1.46	LLS2V681MELC
820	35 × 45	3470	1.60	LLS2V821MELC
1000	35 × 50	3600	1.77	LLS2V102MELC

400V (2G)				
Cap. (μF)	Size φD × L(mm)	Rated ripple (mA)	Leakage Current (mA)	Code
68	20 × 25	750	0.49	LLS2G680MELY
	20 × 30	820	0.54	LLS2G820MELY
82	22 × 25	840	0.54	LLS2G820MELZ
	20 × 30	950	0.60	LLS2G101MELY
100	22 × 25	950	0.60	LLS2G101MELZ
	20 × 35	1070	0.65	LLS2G121MELY
120	22 × 30	1090	0.65	LLS2G121MELZ
	25 × 25	1130	0.65	LLS2G121MELA
	20 × 40	1220	0.73	LLS2G151MELY
150	22 × 35	1240	0.73	LLS2G151MELZ
	25 × 30	1270	0.73	LLS2G151MELA
	22 × 40	1410	0.80	LLS2G181MELZ
180	25 × 30	1440	0.80	LLS2G181MELA
	30 × 25	1520	0.80	LLS2G181MELB
	22 × 45	1580	0.88	LLS2G221MELZ
220	25 × 35	1640	0.88	LLS2G221MELA
	30 × 30	1660	0.88	LLS2G221MELB
	25 × 40	1790	0.98	LLS2G271MELA
270	30 × 30	1820	0.98	LLS2G271MELB
	25 × 45	2000	1.08	LLS2G331MELA
330	30 × 35	2050	1.08	LLS2G331MELB
	35 × 30	2050	1.08	LLS2G331MELC
	30 × 40	2260	1.18	LLS2G391MELB
390	35 × 35	2280	1.18	LLS2G391MELC
	30 × 45	2510	1.30	LLS2G471MELB
470	35 × 35	2510	1.30	LLS2G471MELC
	30 × 50	2850	1.41	LLS2G561MELB
560	35 × 40	2850	1.41	LLS2G561MELC
	35 × 50	3100	1.56	LLS2G681MELC

450V (2W)				
Cap. (μF)	Size φD × L(mm)	Rated ripple (mA)	Leakage Current (mA)	Code
56	20 × 25	610	0.47	LLS2W560MELY
68	20 × 30	710	0.52	LLS2W680MELY
	22 × 25	710	0.52	LLS2W680MELZ
82	20 × 35	800	0.57	LLS2W820MELY
	22 × 25	860	0.57	LLS2W820MELZ
100	20 × 35	880	0.63	LLS2W101MELY
	22 × 30	950	0.63	LLS2W101MELZ
	25 × 25	970	0.63	LLS2W101MELA
120	20 × 40	990	0.69	LLS2W121MELY
	22 × 35	1070	0.69	LLS2W121MELZ
	25 × 30	1090	0.69	LLS2W121MELA
	30 × 25	1120	0.69	LLS2W121MELB
150	22 × 40	1180	0.77	LLS2W151MELZ
	25 × 30	1250	0.77	LLS2W151MELA
	30 × 25	1290	0.77	LLS2W151MELB
180	22 × 45	1320	0.85	LLS2W181MELZ
	25 × 35	1400	0.85	LLS2W181MELA
	30 × 30	1450	0.85	LLS2W181MELB
220	25 × 40	1590	0.94	LLS2W221MELA
	30 × 30	1640	0.94	LLS2W221MELB
	35 × 25	1590	0.94	LLS2W221MELC
270	30 × 35	1890	1.04	LLS2W271MELB
	35 × 30	1900	1.04	LLS2W271MELC
330	30 × 40	2120	1.15	LLS2W331MELB
	35 × 35	2150	1.15	LLS2W331MELC
390	30 × 45	2350	1.25	LLS2W391MELB
	35 × 40	2380	1.25	LLS2W391MELC
470	35 × 45	2680	1.37	LLS2W471MELC
560	35 × 50	2880	1.50	LLS2W561MELC

Rated ripple current (mA_{rms}) at 85° C 120Hz