



CRYSTEK
MICROWAVE
 A DIVISION OF CRYSTEK CORPORATION

VCO EVALUATION BOARDS



Model CEVAL-055 Shown

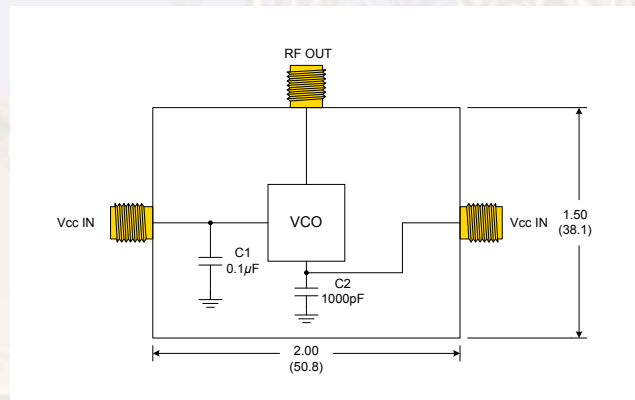

Features:

Connectors: Gold Plated SMA Female Connectors

Frequency Range: DC to 6GHz

PCB: 0.062" FR4

Operating Temperature: -40°C to +85°C

Crystek's VCO Evaluation boards are a turn key solution to easy stand alone testing. Evaluation boards are constructed using rigid 0.062" FR4 PCB material. Solder down connection method insures that the VCO will receive proper grounding for best testing results. Evaluation boards are available for 0.3" x 0.3" and 0.5" x 0.5" Industrial Standard VCO foot prints. Crystek also produces a line of RF Cables that can be purchased seperately to make connection to equipment an effortless task.

Part Number	Description
CEVAL-033	0.3"x 0.3" VCO CVCO33 Model
CEVAL-055	0.5"x 0.5" VCO CVCO55 Model



CRYSTEK
 CORPORATION

12730 COMMONWEALTH DRIVE • FORT MYERS, FL 33913

PHONE: 239-561-3311 • 800-237-3061

FAX: 239-561-1025 • WWW.CRYSTEK.COM

Rev: A
 Date: 01-24-08