

NOTES:

1.0 Materials

- 1.1 Body, Coupling, and Clamp Nuts: Steel. Corrosion Resistant per ASTM-A582. UNS No. S30300.
- 1.2 Center Conductor: Beryllium Copper per ASTM-B196. UNS C17300.
- 1.3 Solder Ferrule: Brass per ASTM-B16. UNS C36000.
- 1.4 Lock Ring: Beryllium Copper per ASTM-B197. UNS C17200.
- 1.5 Gasket and O-Ring: Silicone Rubber per A-A-59588.
- 1.6 Insulator: PTFE Fluorocarbon per ASTM-D1710.
- 1.7 Cable Stop: Polyetherimide Thermoplastic (ULTEM 1000) per ASTM-D5205.

2.0 Finishes

- 2.1 Center Contact and Solder Ferrule: Gold Plate per ASTM-B488 50 Microinches Min. thickness over Electrolytic Nickel Plate per ASTM-B689 50 Microinches Min. thickness.
- 2.2 Body, Coupling, and Clamp Nuts: Passivated per SAE-AMS-2700.
- 2.3 Gasket, O-Ring, Lock Ring, and Dielectrics: None.

3.0 Interface: Type SMA plug per Crystek interface specification CC-SMAP  
(Meets MIL-STD-348. Fig. 310-1).

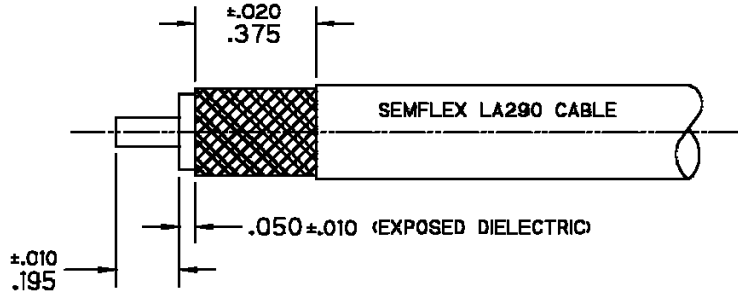

**Step 1** 1.1 Trim Cable as shown.

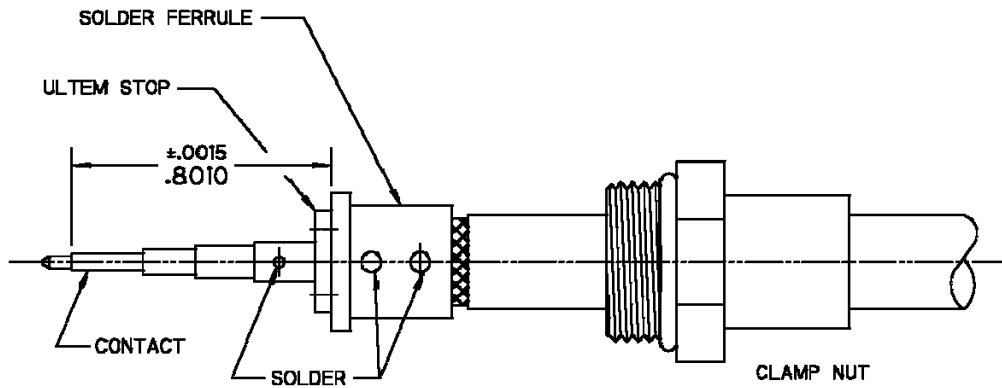

- 2.1 Slide clamp nut over cable as shown.
- 2.2 Insert cable into solder ferrule until cable dielectric is flush with face of ferrule.
- 2.3 Solder both cable braids where shown.
- 2.4 Slide dielectric stop over cable center conductor and solder contact flush against stop to dimension shown.

**Step 2**

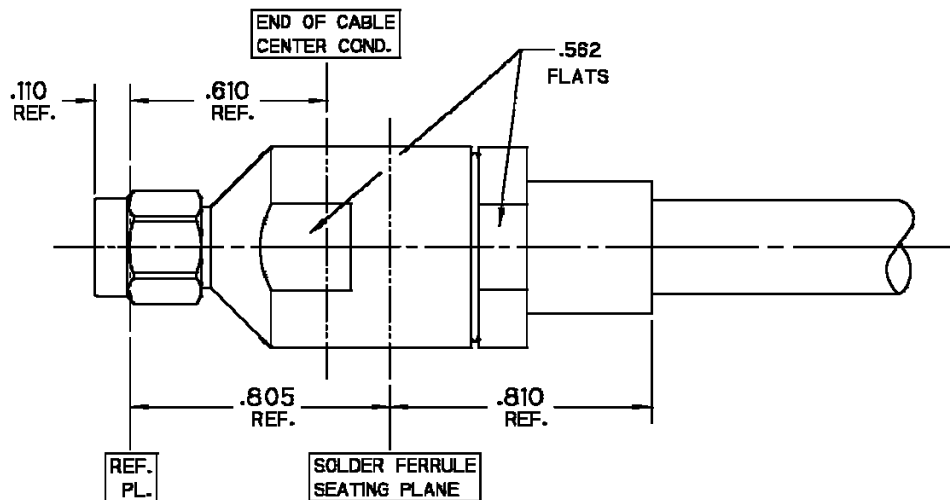

- 3.1 Insert forward insulator into connector in orientation shown.
- 3.2 Insert cable/contact sub-assembly into connector until seated and tighten clamp nut to 35-45 in-lbs.

**Step 3**

**Product Control:**

Crystek Part Number:	CS-SM-MSD	Release Date:	04-Jan-11
Revision Level:	A	Responsible:	K. Piotrowicz