

3 Phase rectifier bridge Power Module

$V_{RRM} = 1600V$
 $I_C = 40A @ T_c = 80^\circ C$

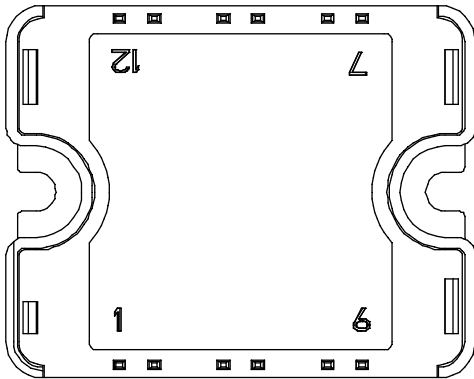
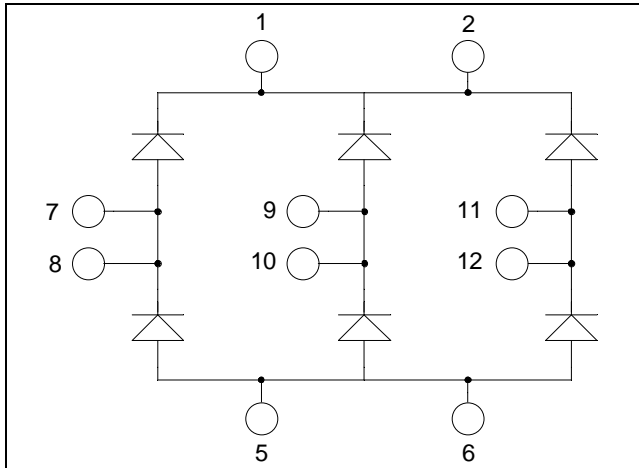

All multiple inputs and outputs must be shorted together
 1/2 ; 5/6 ; 7/8 ; 9/10 ; 11/12

Application

- Input rectifiers for inverter
- Battery DC power supply

Features

- High blocking voltage
- High surge current
- Low leakage current
- Very low stray inductance
 - Symmetrical design
- High level of integration

Benefits

- Solderable terminals for easy PCB mounting
- Direct mounting to heatsink (isolated package)
- Low profile
- RoHS compliant

Absolute maximum ratings

Symbol	Parameter	Max ratings	Unit
V_R	Maximum DC reverse Voltage	1600	V
V_{RRM}	Maximum Peak Repetitive Reverse Voltage		
I_F	DC Forward Current	40	A
I_{FSM}	Non-Repetitive Forward Surge Current	400	
		t=10ms	$T_C = 80^\circ C$
			$T_J = 45^\circ C$

CAUTION: These Devices are sensitive to Electrostatic Discharge. Proper Handling Procedures Should Be Followed. See application note APT0502 on www.microsemi.com

All ratings @ $T_j = 25^\circ\text{C}$ unless otherwise specified

Electrical Characteristics

Symbol	Characteristic	Test Conditions	Min	Typ	Max	Unit
I_R	Reverse Current	$V_R = 1600\text{V}$	$T_j = 25^\circ\text{C}$		20	μA
			$T_j = 125^\circ\text{C}$		2	mA
V_F	Forward Voltage	$I_F = 40\text{A}$	$T_j = 25^\circ\text{C}$		1.3	V
			$T_j = 125^\circ\text{C}$		1.1	
V_T	On – state Voltage			0.8		V
r_T	On – state Slope resistance			10.5		$\text{m}\Omega$

Thermal and package characteristics

Symbol	Characteristic	Min	Typ	Max	Unit	
R_{thJC}	Junction to Case Thermal Resistance			1.5	$^\circ\text{C}/\text{W}$	
V_{ISOL}	RMS Isolation Voltage, any terminal to case $t=1\text{ min}$, $I_{isol}<1\text{mA}$, 50/60Hz	3500			V	
T_J	Operating junction temperature range	-40		150	$^\circ\text{C}$	
T_{STG}	Storage Temperature Range	-40		125		
T_C	Operating Case Temperature	-40		100		
Torque	Mounting torque	To heatsink	M4	2.5	4.7	N.m
Wt	Package Weight			80		g

SP1 Package outline (dimensions in mm)

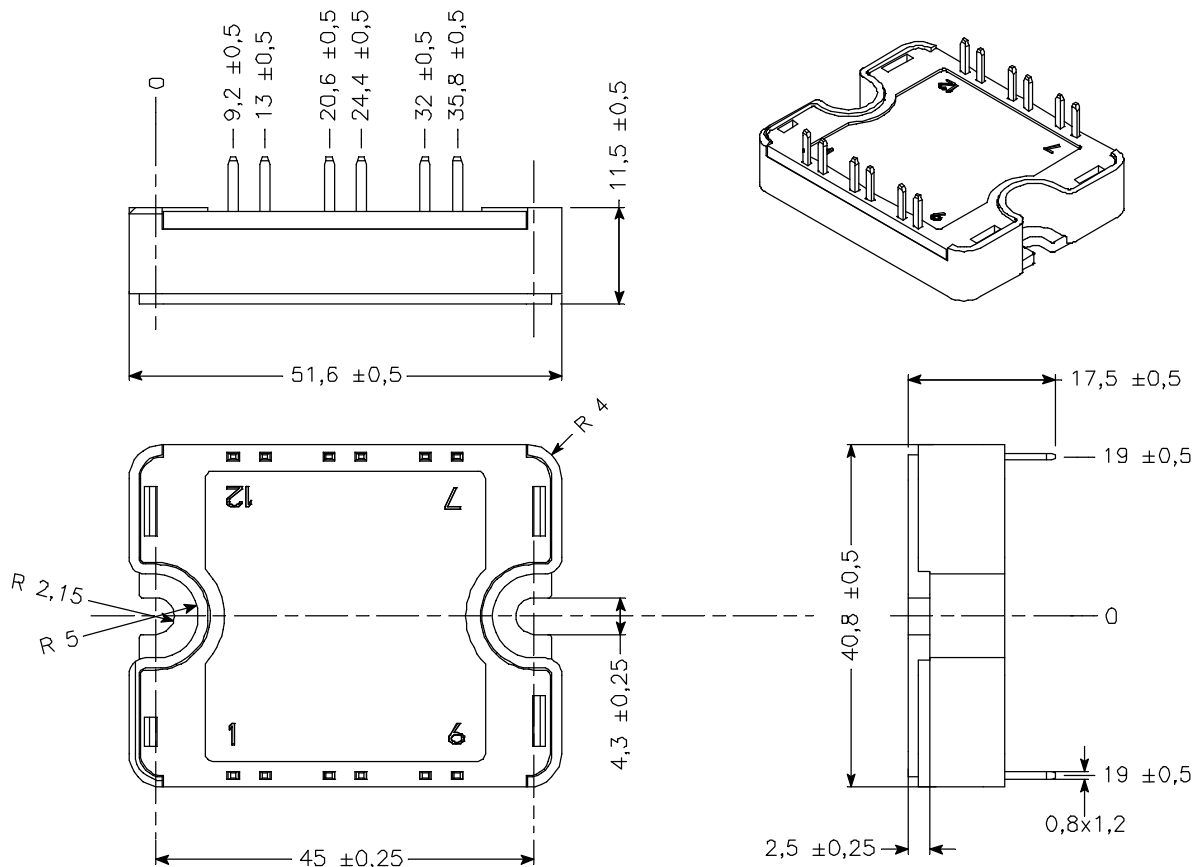

See application note 1904 - Mounting Instructions for SP1 Power Modules on www.microsemi.com

Typical Performance Curve

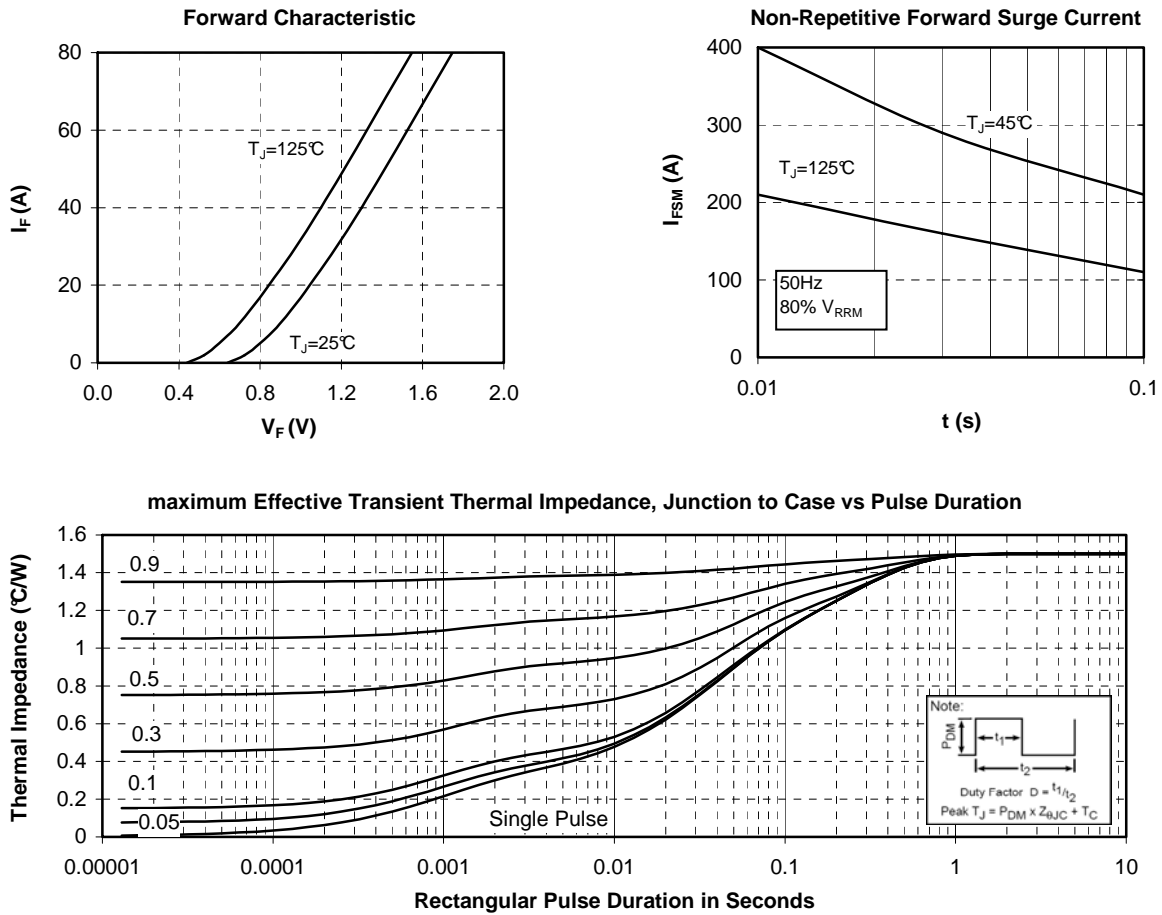

Microsemi reserves the right to change, without notice, the specifications and information contained herein

Microsemi's products are covered by one or more of U.S. patents 4,895,810 5,045,903 5,089,434 5,182,234 5,019,522 5,262,336 6,503,786 5,256,583 4,748,103 5,283,202 5,231,474 5,434,095 5,528,058 and foreign patents. U.S and Foreign patents pending. All Rights Reserved.