

Description

Microsemi's PD69008 Power over Ethernet (PoE) Manager chip integrates power, analog and state of the art embedded core logic into a single 80-pin, plastic QFP package. The device is used in Ethernet switches and Midspans to enable network devices to share power and data over the same cable.

PD69008 device is an 8-port, mixed-signal, high-voltage Power over Ethernet driver. It enables detection of IEEE802.3af-2003 compliant PDs (Powered Devices) and IEEE802.3AT High Power Devices, thus, ensuring safe power feeding and disconnection of ports. With full digital control via a serial communication interface and a minimum of external components, the device integrates into multi-port and highly populated Ethernet switches and routers.

The PD69008 executes all real time functions as specified in the IEEE802.3af-2003 ("AF") standard and IEEE802.3at High Power ("AT") functionality, including load detection, "AF" and "AT" classification and port status monitoring. In addition it performs system level activities such as power management and MIB support for system management. The PoE device is designed to detect and disable disconnected ports, utilizing both DC and AC disconnection methods, as specified in the IEEE 802.3af-2003 standard.

The PD69008 is designed to support 2 main configurations:

- Auto mode: For Basic "AF" and "AT" PSE equipment
- Enhanced mode: For High End, Extended features set of AF and AT PSE equipment

Pin Configuration

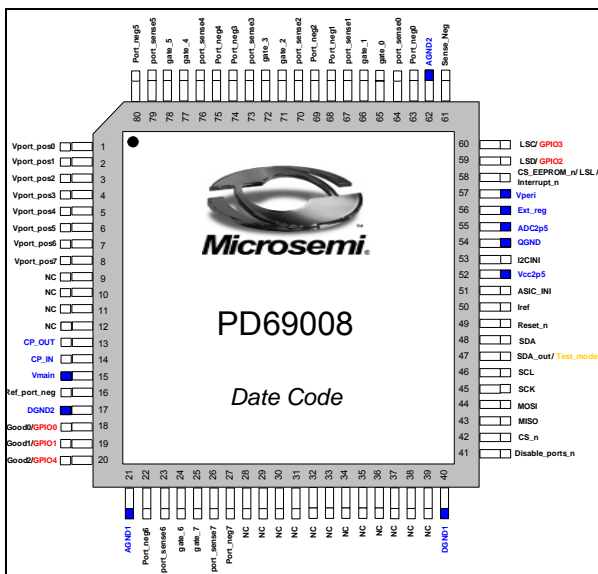

Supported Features

PD69008 Auto Mode features:

- ◆ Fully IEEE802.3af-2003 compliant
- ◆ Designed to support IEEE802.3at including two-event classification
- ◆ Supports pre-standard PD detection
- ◆ Supports Cisco devices detection
- ◆ IETF Power Ethernet MIB (RFC 3621) compliant
- ◆ Single DC voltage input (44v-57v)
- ◆ Wide temperature range: -40° C to +85° C
- ◆ Low thermal dissipation (0.5Ω sense resistor)
- ◆ Drives 8 independent two-pairs power ports or 64-pairs ports
- ◆ Can cascade up to 8 PoE devices (64 ports)
- ◆ EEPROM interface for software patching and parameter configuration
- ◆ I²C Host interface
- ◆ Supports Interrupt out pin
- ◆ Dynamic power management
- ◆ Emergency power management supporting three configurable Power Bank I/Os
- ◆ Direct register communication
- ◆ Direct LED drive supporting one or two colors
- ◆ Continuous monitoring per port and system data
- ◆ Parameter setting per port and per system
- ◆ Power soft start algorithm
- ◆ Thermal monitoring/protection
- ◆ Voltage monitoring/protection
- ◆ H/W disable ports input
- ◆ Built in 3.3 V regulator
- ◆ Internal power on reset
- ◆ Enhanced SPI bus for internal communication
- ◆ External EEPROM for system parameters update
- ◆ SW ROM patch option
- ◆ RoHS compliant

Enhanced Modes Additional Features:

- ◆ I²C or UART Host interface
- ◆ Serial communication protocol backwards compatible with PD63000 and PDIC66000
- ◆ Added monitoring
- ◆ Extended parameters setting
- ◆ Port matrix for flexible PCB Layout
- ◆ Field upgradeable software
- ◆ Emergency Power Management with four power supplies

Ordering Information

Part number	Temperature range	Package
PD69008	-40 to 85°C	LQFP 80 pin

This datasheet refers to ICs with date code "XAA0843" or later.

Date code: See the bottom line (XAA0843) in the Pin Configuration drawing. Where "0843" is the date code, "08" is the year (2008), and "43" is the week.

Package Information

The PD69008 is packed in an 80-pin LQFP plastic package, 12 x 12 x 1.4 mm with exposed pad

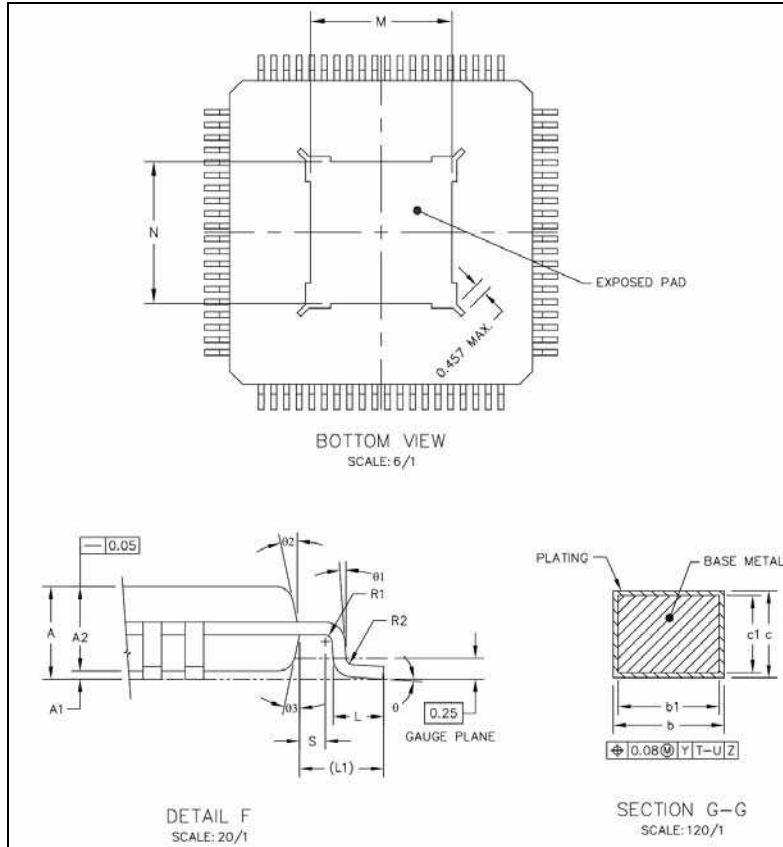

NOTES:

- DATUMS T, U AND Z TO BE DETERMINED WHERE THE LEADS EXIT THE PLASTIC BODY AT DATUM PLANE H.
- DIMENSIONS D AND E DO NOT INCLUDE MOLD PROTRUSION. ALLOWABLE PROTRUSION IS 0.25mm PER SIDE. DIMENSIONS D AND E ARE MAXIMUM PLASTIC BODY SIZE DIMENSIONS INCLUDING MOLD MISMATCH.
- DIMENSION b DOES NOT INCLUDE DAM BAR PROTRUSION. ALLOWABLE DAM BAR PROTRUSION SHALL NOT CAUSE THE LEAD WIDTH TO EXCEED THE MAXIMUM b DIMENSION BY MORE THAN 0.08mm. DAM BAR CAN NOT BE LOCATED ON THE LOWER RADIUS OR THE FOOT. MINIMUM SPACE BETWEEN A PROTRUSION AND AN ADJACENT LEAD IS 0.07mm.

△ EXACT SHAPE OF EACH CORNER IS OPTION.

DIM	MIN	NOM	MAX	DIM	MIN	NOM	MAX
A	---	1.2		L1		1 REF	
A1	0.05	0.15		R1	0.08	---	
A2	0.95	1	1.05	R2	0.08	0.2	
b	0.17	0.22	0.27	S	0.2	---	
b1	0.17	0.2	0.23	θ	0°	7°	
c	0.09	0.2		θ1	0°	---	
c1	0.09	0.16		θ2	11°	13°	
D		14 BSC		θ3	11°	13°	
D1		12 BSC		M	5.5	5.6	5.7
e		0.5 BSC		N	5.5	5.6	5.7
E		14 BSC					
E1		12 BSC					
L	0.45	0.6	0.75	UNIT		DIMENSION AND TOLERANCES	
				MM		ASME Y14.5M	

Figure 1: PD69008 Package Description

Maximum Ratings

V_{main}	-0.3 to 80 V ⁽¹⁾
DGND, AGND, QGND, SENSE_NEG.....	-0.3 to 0.3 V ⁽²⁾
V_{PORT_POSx}	-0.3 to 80 V ⁽¹⁾
V_{PORT_NEGx} , REF_PORT_NEG.....	-8.4 to 80V ⁽¹⁾
$V_{PORT_POSx} - V_{PORT_NEGx}$	-0.3 to 80 V ⁽¹⁾
PORT_SENSE _x	-7.2 to 25 V ⁽¹⁾
Gate_x.....	-0.3 to 18 V
VCC _{2p5} , ADC _{2p5}	-0.3 to 3 V
V _{PERI}	4 V
EXT_REG.....	-0.3 to 6 V
I2CINI, ASICINI.....	-0.3 to 3 V
MISO, MOSI, SCK, SCL, SDA, CLK, RESETN, CS_N, INTERRUPT, POWER_BANK[2..0], LSD, LSC, LSL, SDA_OUT.....	-0.3 to ($V_{PERI} + 0.3$) V
ESD (Human Body Model).....	-2 to 2 kV ⁽³⁾
Max junction temperature (T_{junc}).....	+150 °C
Junction-ambient thermal resistance (θ_{JA}).....	30° C/W ⁽⁴⁾
Junction-case thermal resistance (θ_{JC}).....	10° C/W
Lead temperature (soldering, 10 s).....	260° C
Storage temperature.....	-40° to +125° C

Notes: "x" defines port numbers, 0 thru 3, inclusive.

⁽¹⁾ 80 V is the transient voltage that can be applied for 1 min max.

⁽²⁾ Maximum value between grounds.

⁽³⁾ ESD testing is performed in accordance with the Human Body Model (CZap = 100 pF, RZap = 1500 Ω).

⁽⁴⁾ with 4ML PCB – no air flow

Stresses beyond those listed above, may cause permanent damage to the device. Exposure to absolute maximum rating conditions for extended periods, may affect device reliability.

Operating Conditions

PARAMETER	MIN.	NOM.	MAX.	UNIT
Operating temperature At full load ambient	-40		+85	° C
Operational limitations (1)	15 to 44	44 to 55	55 to 57	V

(1) Operating functions depend on the input voltage, as shown in Figure 2.

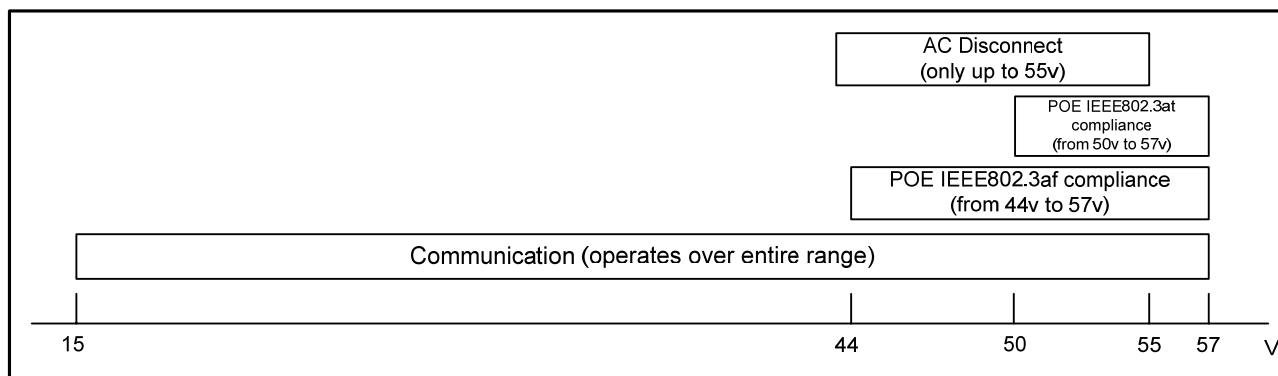

Figure 2: Operational Ranges

Electrical Characteristics

PIN NAME:	<ul style="list-style-type: none"> • SCL • DISABLE_PORTS_N 					
PAD TYPE:	Schmitt Trigger CMOS input, TTL Level with no internal Res.					
PARAMETER	SYMBOL	MIN	TYP	MAX	UNIT	NOTE
High Level Input Voltage	V_{IH}	2.0			V	
Low Level Input Voltage	V_{IL}			0.8	V	
Input Voltage Hysteresis		0.3			V	
Input High Current	I_{IH}	-1		1	μA	
Input Low Current	I_{IL}	-1		1	μA	

PIN NAME:	<ul style="list-style-type: none"> • LSD Multiplexed with GPIO_2 • LSC Multiplexed with GPIO_3 • POWER_GOOD0 Multiplexed with GPIO_0 • POWER_GOOD1 Multiplexed with GPIO_1 • POWER_GOOD2 Multiplexed with GPIO_4 					
PAD TYPE:	CMOS I/O, TTL Level with no internal pull up / pull down resistor, with Schmitt trigger Input					
PARAMETER	SYMBOL	MIN	TYP	MAX	UNIT	NOTE
High Level Input Voltage	V_{IH}	2.0			V	
Low Level Input Voltage	V_{IL}			0.8	V	
Input Voltage Hysteresis		0.3			V	
Input High Current	I_{IH}	-1		+1	μA	
Input Low Current	I_{IL}	-1		+1	μA	
High Level Output Voltage		VPERI- 0.4V			V	Iout=-2 mA
Low Level Output Voltage				0.4	V	Iout=2 mA

PIN NAME:	<ul style="list-style-type: none"> • SCK • CS_N • MOSI 					
PAD TYPE:	CMOS I/O, TTL Level with internal pull up current source, with Schmitt trigger Input					
PARAMETER	SYMBOL	MIN	TYP	MAX	UNIT	NOTE
High Level Input Voltage	V_{IH}	2.0			V	
Low Level Input Voltage	V_{IL}			0.8	V	
Input Voltage Hysteresis		0.3			V	
Input High Current	I_{IH}	-1		+1	μ A	
Input Low Current	I_{IL}	-1		+1	μ A	
High Level Output Voltage		VPERI- 0.4 V			V	Iout = -2 mA
Low Level Output Voltage				0.4	V	Iout = 2 mA
Pull up current		10	20	50	μ A	

PIN NAME:	<ul style="list-style-type: none"> • MISO 					
PAD TYPE:	CMOS I/O, TTL Level with internal pull up current source, with Schmitt trigger Input					
PARAMETER	SYMBOL	MIN	TYP	MAX	UNIT	NOTE
High Level Input Voltage	V_{IH}	2.0			V	
Low Level Input Voltage	V_{IL}			0.8	V	
Input Voltage Hysteresis		0.3			V	
Input High Current	I_{IH}	-1		+1	μ A	
Input Low Current	I_{IL}	-1		+1	μ A	
High Level Output Voltage		VPERI- 0.4V			V	Iout = -2 mA
Low Level Output Voltage				0.4	V	Iout = 2 mA
Pull down current		10	20	50	μ A	

PIN NAME:	<ul style="list-style-type: none"> • RESET_N • SDA • SDA_OUT Multiplexed with TEST_MODE 					
PAD TYPE:	Digital I/O – input/output open drain CMOS Open Drain Output with Schmitt Trigger Input, TTL Level (external pull up res. Only))					
PARAMETER	SYMBOL	MIN	TYP	MAX	UNIT	NOTE
High Level Input Voltage	V _{IH}	2.0			V	
Low Level Output Voltage	V _{OL}			0.4	V	I _{out} = 6 mA
Low Level Input Voltage	V _{IL}			0.8	V	
Input Voltage Hysteresis		0.3			V	
OFF State Output Current		-1		+1	uA	

PIN NAME:	<ul style="list-style-type: none"> • CS_EEPROM & LSL Multiplexed with INTERRUPT_N 					
PAD TYPE:	CMOS Open Drain Output (external pull up res. Only))					
PARAMETER	SYMBOL	MIN	TYP	MAX	UNIT	NOTE
Low Level Output Voltage				0.4	V	I _{out} = 6 mA
OFF State Output Current		-1		+1	uA	

PIN NAME:	<ul style="list-style-type: none"> • VPORT_NEGx • REF_PORT_NEG 					
PAD TYPE:	High Voltage Analog Pad					
PARAMETER	SYMBOL	MIN	TYP	MAX	UNIT	NOTE
Pin Current Consumption		-10		+10	uA	Port driver OFF, Vport differential measurement OFF, AC generator OFF

PIN NAME:	• PORT_SENSE_x					
PAD TYPE:	Low Voltage Analog Pad					
PARAMETER	SYMBOL	MIN	TYP	MAX	UNIT	NOTE
Operating Voltage		0		0.5	V	With external 0.5 Ohms 2% to GND
Internal Current Consumption				20	uA	

PIN NAME:	<ul style="list-style-type: none"> • VPORT_POS_x • VPORT_NEG_x 					
PAD TYPE:	High Voltage Analog Pad					
PARAMETER	SYMBOL	MIN	TYP	MAX	UNIT	NOTE
Operating Voltage (to GND)		0		62	V	

PIN NAME:	• VMAIN					
PAD TYPE:	High Voltage Supply Pad					
PARAMETER	SYMBOL	MIN	TYP	MAX	UNIT	NOTE
Operating Voltage		44		57	V	
VMAIN Current Consumption			13.6	16	mA	Total on VMAIN

PIN NAME:	• CP_OUT					
PAD TYPE:	Analog					
PARAMETER	SYMBOL	MIN	TYP	MAX	UNIT	NOTE
Operating voltage		44		68	V	
Pin Internal Current Consumption				5	mA	

PIN NAME:	• CP_IN					
PAD TYPE:	Analog					
PARAMETER	SYMBOL	MIN	TYP	MAX	UNIT	NOTE
Operating Voltage		34		57	V	

PIN NAME:	• ADC2p5, VCC2p5, VPERI, EXT_REG					
PAD TYPE:	Analog					
PARAMETER	SYMBOL	MIN	TYP	MAX	UNIT	NOTE
ADC2p5 Output Voltage		2.45		2.55	V	
ADC2p5 Internal Current Consumption				6	mA	Recommended external cap. = 47 nF to 135 nF
VCC2p5 Output Voltage		2.37		2.62	V	Recommended external cap. = 47 nF to 135 nF
VPERI Output Voltage		3.10		3.5	V	Recommended external cap. = 1 uF to 4.7 uF
VPERI External Current Load				6	mA	Without external NPN
EXT_REG Output Current				6	mA	

PIN NAME:	• ASICINI, I2CINI (max. capacitance between mode input to GND should NOT exceed 1nF)					
PAD TYPE:	Analog					
PARAMETER	SYMBOL	MIN	TYP	MAX	UNIT	NOTE
Operating Voltage		0		ADC2p5	V	
Current Consumption		-1		+1	uA	

PIN NAME:	• IREF					
PAD TYPE:	Analog					
PARAMETER	SYMBOL	MIN	TYP	MAX	UNIT	NOTE
Output Voltage		1.21		1.34	V	With external 24.9 K resistor to GND

PIN NAME:	• FET_Gx					
PAD TYPE:	Analog					
PARAMETER	SYMBOL	MIN	TYP	MAX	UNIT	NOTE
Output voltage		12		15	V	

Dynamic Characteristics

The PD69008 utilizes three programmable current level thresholds (I_{min} , I_{cut} , I_{lim}) and three timers (T_{min} , T_{cut} , T_{lim}). Loads that dissipate more than I_{cut} for longer than T_{cut} are classified as 'overloads' and are automatically shutdown. Loads that consume I_{lim} current for more than T_{lim} are shutdown and classified as 'short circuit state'.

In cases where the PD69008 is configured to operate in DC-Disconnect mode, and the output current is below I_{min} for more than T_{min} , the PD is classified as 'no-load' and is shutdown. In cases where the PD69008 is configured to operate in AC-Disconnect mode, and the load's impedance is above a pre-defined impedance for more than T_{min} , the PD is classified as 'no-load' and is shutdown.

Automatic recovery from overload and no-load conditions is attempted every period of T_{OVLREC} and T_{UDLREC} (typically 5 and 1 seconds, respectively). Output power is limited to I_{lim} , which is a maximum peak current allowed at the port.

AF Ports Parameters

PARAMETER	CONDITIONS		MIN.	TYP.	MAX.	UNIT
Automatic recovery from overload shutdown	T_{OVLREC} value, measured from port shutdown (can be modified through control port)			5		s
Automatic recovery from no-load shutdown	T_{UDLREC} value, measured from port shutdown (can be modified through control port)			1		s
Cutoff timers accuracy	Typical accuracy of T_{cut}		4	2	0	ms
Inrush current	I_{Inrsh}	For $t=50$ ms, $C_{load}=180$ uF max.	400		450	mA
Output current operating range	I_{port}	Continuous operation after startup period.	10		375	mA
Output power available, operating range	P_{port}	Continuous operation after startup period, at port output.	0.57		15.4	W
Off mode current	I_{min1}	Must disconnect for t greater than T_{UVL}	0		5	mA
	I_{min2}	May or may not disconnect for t greater than T_{UVL}	5	7.5	10	mA
PD power maintenance request drop-out time limit	T_{PMDO}	Buffer period to handle transitions	300		400	ms
Over load current detection range	I_{cut}	Time limited to T_{OVL}	350		400	mA
Over load time limit	T_{OVL}		50		75	ms
Turn on rise time	T_{rise}	From 10% to 90% of V_{port} (Specified for PD load consisting of 100 uF capacitor in parallel to 200 Ω).	15			us
Turn off time	T_{off}	From V_{port} to 2.8 Vdc			500	ms
Time Maintain Power Signature	T_{MPS}	DC modulation time for dc disconnect		49		ms
AC disconnect impedance	Z_{ac}		27	600	2000	K Ω

AT Ports Parameters

PARAMETER	CONDITIONS		MIN.	TYP.	MAX.	UNIT
Automatic recovery from overload shutdown	T _{OVLREC} value, measured from port shutdown (can be modified through control port)			5		s
Automatic recovery from no-load shutdown	T _{UDLREC} value, measured from port shutdown (can be modified through control port)			1		s
Cutoff timers accuracy	Typical accuracy of T _{cut}		4	2	0	ms
Inrush current	I _{Inrsh}	For t=50 ms, C _{load} =180 uF max.	400		450	mA
Output current operating range	I _{port}	Continuous operation after startup period.	10		643	mA
Output power available, operating range	P _{port}	Continuous operation after startup period, at port output.	0.57		36.25	W
Off mode current	I _{min1}	Must disconnect for t greater than T _{UVL}	0		5	mA
	I _{min2}	May or may not disconnect for t greater than T _{UVL}	5	7.5	10	mA
PD power maintenance request drop-out time limit	T _{PMDO}	Buffer period to handle transitions	300		400	ms
Over load current detection range	I _{cut}	Time limited to T _{OVL}	686	728	771	mA
Over load time limit	T _{OVL}		50		75	ms
Turn on rise time	T _{rise}	From 10% to 90% of V _{port} (Specified for PD load consisting of 100 uF capacitor in parallel to 200 Ω).	15			us
Turn off time	T _{off}	From V _{port} to 2.8 Vdc			500	ms
Time Maintain Power Signature	TMPS	DC modulation time for dc disconnect		49		ms
AC disconnect impedance	Z _{ac}		27	600	2000	KΩ

Pin Description

Pin	Pin Name [Package]	Pin Type	Description
0	PAD	Gnd	Exposed pad connected to underside of die
1	VPORT_POS0	Analog I/O	Port 0 positive input
2	VPORT_POS1	Analog I/O	Port 1 positive input
3	VPORT_POS2	Analog I/O	Port 2 positive input
4	VPORT_POS3	Analog I/O	Port 3 positive input
5	VPORT_POS4	Analog I/O	Port 4 positive input
6	VPORT_POS5	Analog I/O	Port 5 positive input
7	VPORT_POS6	Analog I/O	Port 6 positive input
8	VPORT_POS7	Analog I/O	Port 7 positive input
9	NC		Not Connected
10	NC		Not Connected
11	NC		Not Connected
12	NC		Not Connected
13	CP_OUT	Analog I/O	Charge Pump Output Pulse
14	CP_IN	Supply	Charge pump input
15	VMAIN	Supply	Main Voltage supply
16	REF_PORT_NEG	Analog I/O	Port negative reference
17	DGND2	GND	Digital ground
18	POWER_GOOD0 MULTIPLEXED WITH GPIO_0	Digital I/O	Power supply monitoring Multiplexed with General purpose I/O
19	POWER_GOOD1 MULTIPLEXED WITH GPIO_1	Digital I/O	Power supply monitoring Multiplexed with General purpose I/O
20	POWER_GOOD2 MULTIPLEXED WITH GPIO_4	Digital I/O	Power supply monitoring Multiplexed with General purpose I/O
21	AGND1	GND	Analog ground
22	VPORT_NEG6	Analog I/O	Port 6 negative voltage feeding
23	PORT_SENSE6	Analog I/O	Channel current monitoring
24	FET_G6	Analog I/O	Port 6 – Gate control
25	FET_G7	Analog I/O	Port 7 – Gate control
26	PORT_SENSE7	Analog I/O	Channel current monitoring
27	VPORT_NEG7	Analog I/O	Port 7 negative voltage feeding
28	NC		Not Connected
29	NC		Not Connected
30	NC		Not Connected
31	NC		Not Connected
32	NC		Not Connected
33	NC		Not Connected
34	NC		Not Connected
35	NC		Not Connected
36	NC		Not Connected
37	NC		Not Connected
38	NC		Not Connected
39	NC		Not Connected
40	DGND1	GND	Digital ground
41	DISABLE_PORTS_N	Digital Input	Disable All Ports Power – Active Low
42	CS_N	Digital I/O	SPI bus, Chip Select
43	MISO	Digital I/O	SPI bus, Master Data in/slave out

Pin	Pin Name [Package]	Pin Type	Description
44	MOSI	Digital I/O	SPI bus, Master Data out/slave in
45	SCK	Digital I/O	SPI bus, Serial clock I/O
46	SCL	Digital Input	I2C bus, Serial Clock Input
47	SDA_OUT MULTIPLEXED WITH TEST_MODE	Digital I/O	Third pin in I ² C protocol Test Mode Pin – Must be tied to VPERI with pull-up resistor if not used
48	SDA	Digital I/O	I2C bus, open drain
49	RESET_N	Digital I/O	Active Low Reset I/O
50	IREF	Analog I/O	Current reference
51	ASICINI	Analog Input	Analog input for Asic initialization
52	VCC2P5	Internal Regulator	Internal 2.5v source – not to be used for external devices
53	I2CINI	Analog Input	Analog input for I2C initialization
54	QGND	GND	Quiet analog ground
55	ADC2P5	Internal reference	ADC reference – not to be used for external devices
56	EXT_REG	Analog Out	External regulation
57	VPERI	Analog Out	Regulated 3.3v output voltage source for external devices
58	CS_EEPROM_N & LSL MULTIPLEXED WITH INTERRUPT_N	Digital Output Open drain	SPI bus, EEPROM Chip Select & LED Stream Latch (if set) Multiplexed with interrupt out
59	LSD MULTIPLEXED WITH GPIO_2	Digital I/O	LED Stream Data – data out Multiplexed with General purpose I/O
60	LSC MUXED WITH GPIO_3	Digital I/O	LED Stream CLK– CLK out Multiplexed with General purpose I/O
61	SENSE_NEG	Analog I/O	Port sense reference
62	AGND2	GND	Analog ground
63	VPORT_NEG0	Analog I/O	Port 0 negative voltage feeding
64	PORT_SENSE0	Analog I/O	Channel current monitoring
65	FET_G0	Analog I/O	Port 0 – Gate control
66	FET_G1	Analog I/O	Port 1 – Gate control
67	PORT_SENSE1	Analog I/O	Channel current monitoring
68	VPORT_NEG1	Analog I/O	Port 1 negative voltage feeding
69	VPORT_NEG2	Analog I/O	Port 2 negative voltage feeding
70	PORT_SENSE2	Analog I/O	Channel current monitoring
71	FET_G2	Analog I/O	Port 2 – Gate control
72	FET_G3	Analog I/O	Port 3 – Gate control
73	PORT_SENSE3	Analog I/O	Channel current monitoring
74	VPORT_NEG3	Analog I/O	Port 3 negative voltage feeding
75	VPORT_NEG4	Analog I/O	Port 4 negative voltage feeding
76	PORT_SENSE4	Analog I/O	Channel current monitoring
77	FET_G4	Analog I/O	Port 4 – Gate control
78	FET_G5	Analog I/O	Port 5 – Gate control
79	PORT_SENSE5	Analog I/O	Channel current monitoring
80	VPORT_NEG5	Analog I/O	Port 5 negative voltage feeding

Configuration Pins

There are two main configuration pins utilized in the PD69008 (as shown in Figure 3) which configure the operation mode of the chip and the communication addresses (SPI and I²C).

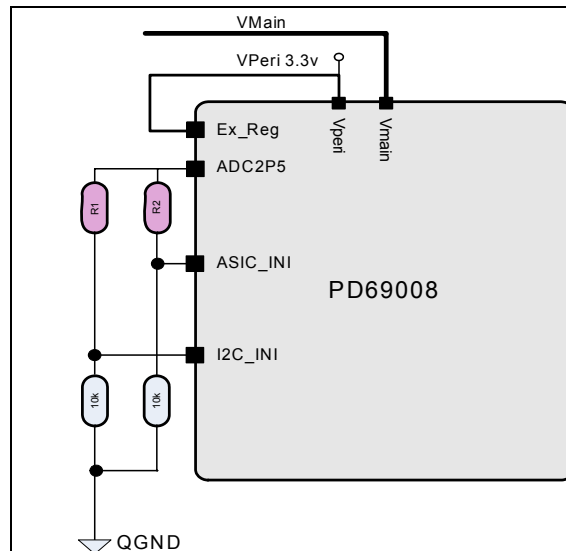

Figure 3: Electronic Connection of Configuration Pins

Application information

The PD69008 can be integrated into a number of applications such as daughter boards, Ethernet switches or routers. Examples of such applications are described below:

Integrated directly into a switch: Facilitates entire PoE concept by including the IC(s) on the main switch's PCB.

Daughter board add-on: The IC is integrated into a small dedicated PoE PCB, mounted on top of the switch's main PCB or into a DIMM module.

Integrated into an RJ45 connector: Saves space on the main board and creates small differences between the PoE and non-PoE versions of a switch.

Midspans: Stand-alone devices, installed between the Ethernet switch and the PDs (Powered Devices) such as telephones, cameras, wireless LANs, etc.

These Midspans include the PD69008 IC as a PoE control element, destined to inject power over the communication lines.

Figure 4 and Figure 5 provide examples of basic applications of the PD69008 in an AC Disconnect Mode and the DC Disconnect Mode:

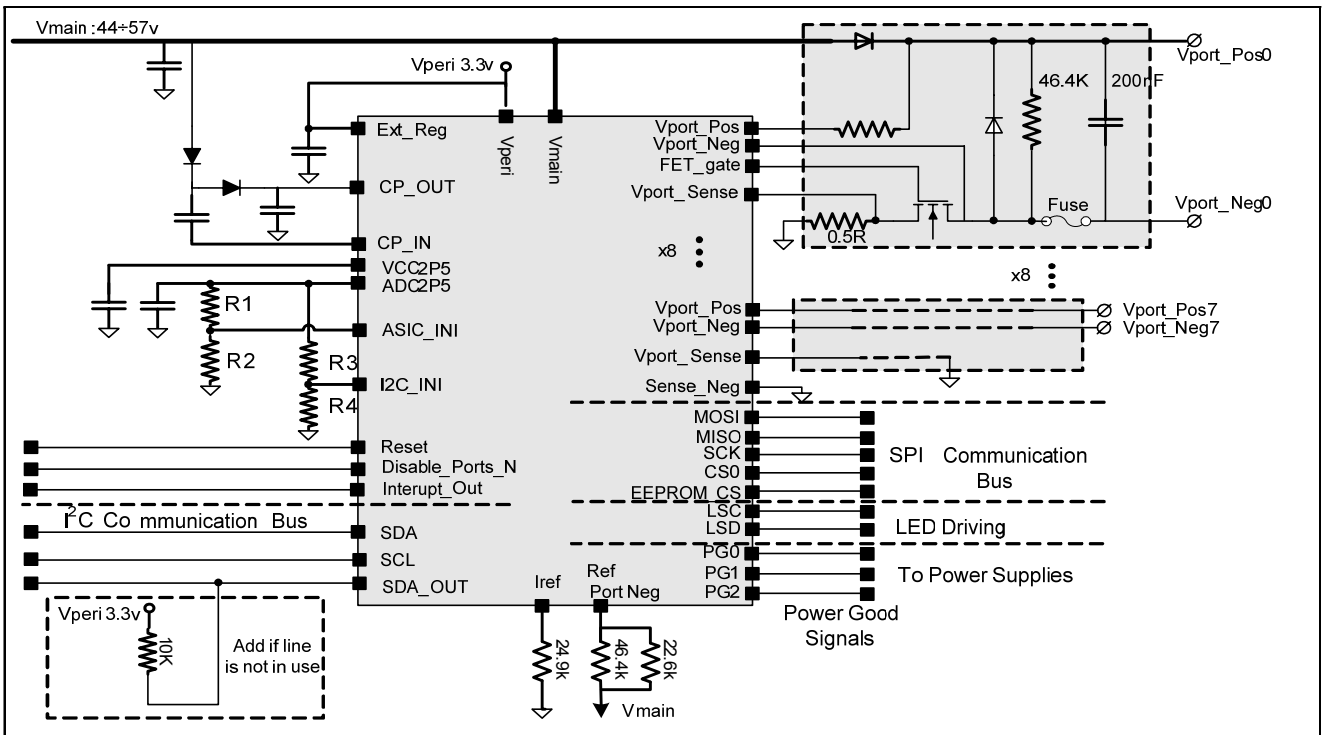
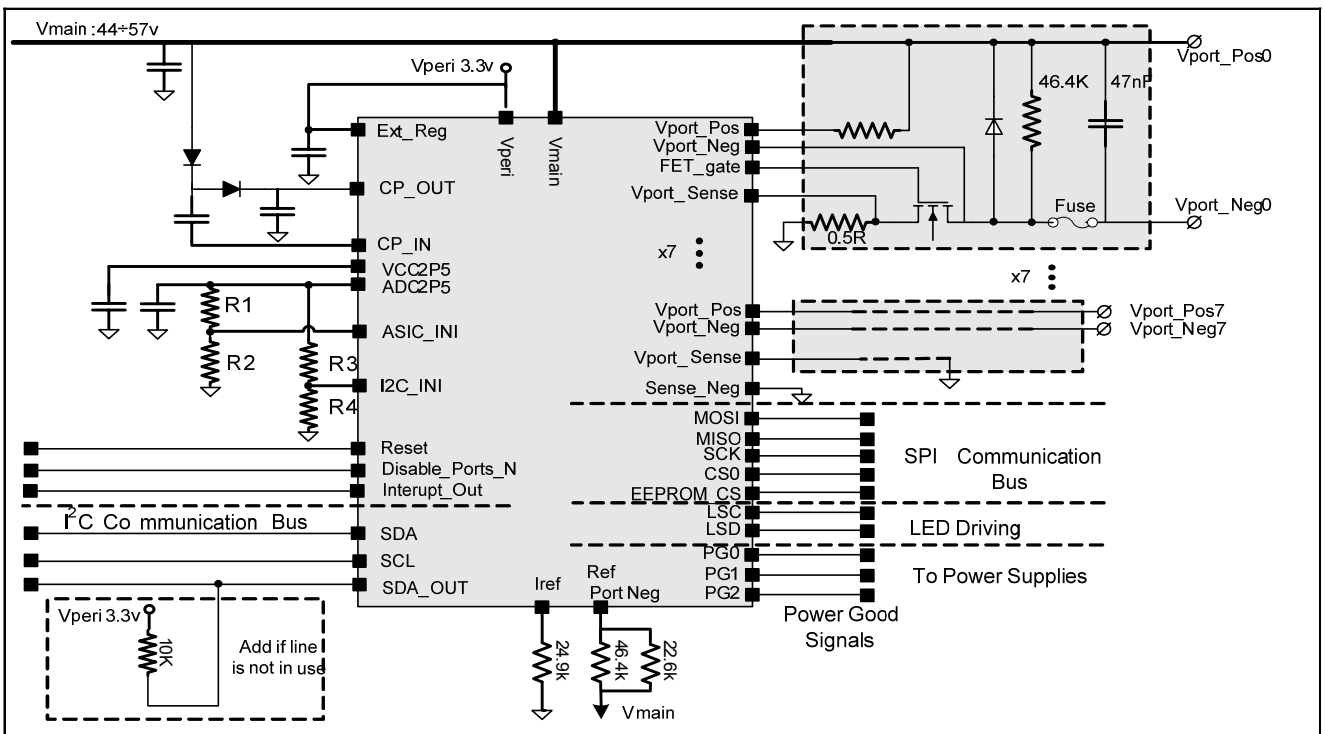
Figure 4: Basic Application with AC Disconnect Support

Figure 5: Basic Application with DC Disconnect Support

The information contained in the document is PROPRIETARY AND CONFIDENTIAL information of Microsemi and cannot be copied, published, uploaded, posted, transmitted, distributed or disclosed or used without the express duly signed written consent of Microsemi. If the recipient of this document has entered into a disclosure agreement with Microsemi, then the terms of such Agreement will also apply. This document and the information contained herein may not be modified, by any person other than authorized personnel of Microsemi. No license under any patent, copyright, trade secret or other intellectual property right is granted to or conferred upon you by disclosure or delivery of the information, either expressly, by implication, inducement, estoppel or otherwise. Any license under such intellectual property rights must be approved by Microsemi in writing signed by an officer of Microsemi. Microsemi reserves the right to change the configuration, functionality and performance of its products at anytime without any notice. This product has been subject to limited testing and should not be used in conjunction with life-support or other mission-critical equipment or applications. Microsemi assumes no liability whatsoever, and Microsemi disclaims any express or implied warranty, relating to sale and/or use of Microsemi products including liability or warranties relating to fitness for a particular purpose, merchantability, or infringement of any patent, copyright or other intellectual property right. The product is subject to other terms and conditions which can be located on the web at <http://www.microsemi.com/legal/tnc.asp>

Revision History

Revision Level / Date	Para. Affected	Description
0.1 / 15 March 2009	-	Initial Preliminary Release
1.0 / 25-Aug-09		Release

© 2009 Microsemi Corp.**All rights reserved.**For technical support contact: sales_AMSG@microsemi.com.**Cat. No. 06-0079-058**