

DESCRIPTION

The LX1742 is a compact high efficiency step-up boost controller. Featuring a pseudo-hysteretic pulse frequency modulation topology, the LX1742 was designed for maximum efficiency, reduced board size, and minimal cost.

Utilizing an internal N-Channel MOSFET, the LX1742 offers designers maximum flexibility with respect to efficiency and cost. The LX1742 provides several design enhancements that improve overall performance under very light load currents by implementing control circuitry that is optimized for portable systems - thus providing a quiescent supply current of only 80 μ A (typ) and a shutdown current of less than 1 μ A.

The input voltage ranges from 1.6V to 6.0V, allowing for a wide selection of system battery voltages. Start-up operation is guaranteed at 1.6V input

The LX1742 is capable of achieving output voltages as high as 25V and the output voltage is easily programmed using two external resistors in conjunction with the feedback pin.

The LX1742 has an additional feature for simple dynamic adjustment of the output voltage (i.e., up to $\pm 15\%$ of the nominal output voltage). Voltage adjustment is achieved via an analog reference signal or a direct PWM input signal applied to the ADJ pin. Any PWM amplitude is easily accommodated with a single external resistor.

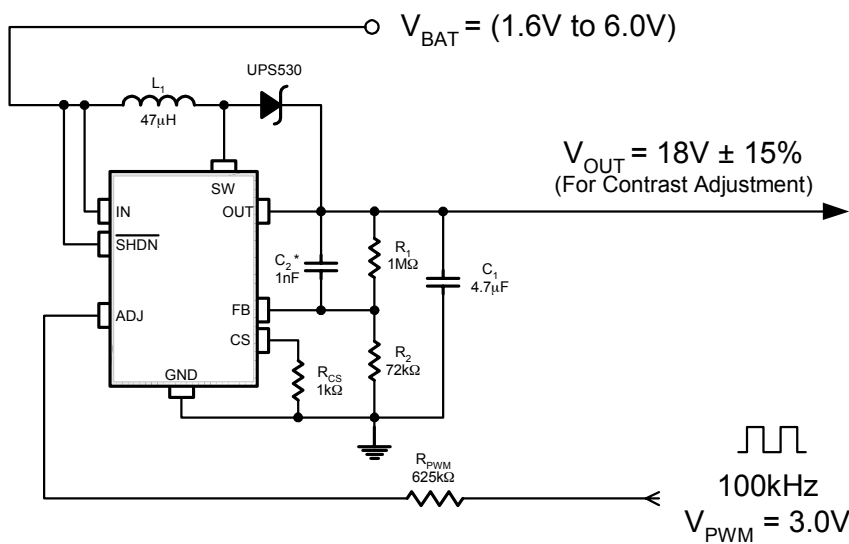
KEY FEATURES

- 80% Typical Efficiency
- 80 μ A Typical Quiescent Supply Current
- Externally Programmable Peak Inductor Current Limit For Maximum Efficiency
- Logic Controlled Shutdown
- < 1.0 μ A Shutdown Current (typ)
- Dynamic Output Voltage Adjustment Via Analog Reference Or Direct PWM Input
- 8-Pin MSOP Package

APPLICATIONS/BENEFITS

- Pagers
- Wireless Phones
- PDAs
- Handheld Computers
- General LCD Bias Applications
- LED Driver

IMPORTANT: For the most current data, consult MICROSEMI's website: <http://www.microsemi.com>

PRODUCT HIGHLIGHT

PACKAGE ORDER INFO

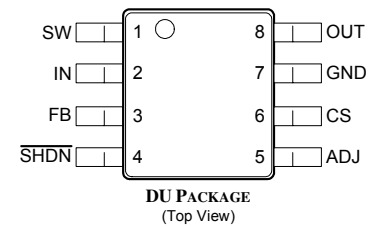
T_A (°C)	DU Plastic MSOP 8-Pin
	RoHS Compliant / Pb-free Transition DC: 0432
0 to 70	LX1742CDU

Note: Available in Tape & Reel. Append the letters "TR" to the part number. (i.e. LX1742CDU-TR)

ABSOLUTE MAXIMUM RATINGS

Supply Voltage (V_{IN})	-0.3V to 7.0V
Output Voltage (OUT)	25.0V
Feedback Input Voltage (V_{FB})	-0.3V to $V_{IN} + 0.3V$
Shutdown Input Voltage ($V_{\overline{SHDN}}$)	-0.3V to $V_{IN} + 0.3V$
PWM Input Amplitude	-0.3V to $V_{IN} + 0.3V$
Analog Adjust Input Voltage (V_{ADJ})	-0.3V to V_{IN}
Source Input Current (I_{SRC})	500mA _{RMS}
Operating Junction Temperature	150°C
Storage Temperature Range	-65°C to 150°C
Peak Package Solder Reflow Temp. (40 second max. exposure)	260°C (+0, -5)

Note: Exceeding these ratings could cause damage to the device. All voltages are with respect to Ground. Currents are positive into, negative out of specified terminal.

PACKAGE PIN OUT


RoHS / Pb-free 100% Matte Tin Lead Finish

THERMAL DATA
DU Plastic MSOP 8-Pin

THERMAL RESISTANCE-JUNCTION TO AMBIENT, θ_{JA}	206°C/W
THERMAL RESISTANCE-JUNCTION TO CASE, θ_{JC}	39°C/W

Junction Temperature Calculation: $T_J = T_A + (P_D \times \theta_{JC})$. The θ_{JA} numbers are guidelines for the thermal performance of the device/pc-board system. All of the above assume no ambient airflow.

FUNCTIONAL PIN DESCRIPTION

NAME	DESCRIPTION
IN	Unregulated IC Supply Voltage Input – Input range from +1.6V to 6.0V. Bypass with a 1 μ F or greater capacitor.
FB	Feedback Input – Connect to a resistive divider network between the output and GND to set the output voltage between V_{CC} (IN) and 25V. The feedback threshold is 1.20V.
\overline{SHDN}	Active-Low Shutdown Input – A logic low shuts down the device and reduces the supply current to 0.1 μ A. When shutdown, the LX1742 isolates the output from the input by turning off the internal MOSFET between LX and OUT. Connect \overline{SHDN} to V_{CC} for normal operation.
SW	Inductor Switching Connection – Internally connected to the drain of a 28V N-channel MOSFET. LX is high impedance in shutdown.
CS	Current-Sense Amplifier Input – Connecting a resistor between CS and GND sets the peak inductor current limit.
GND	Common terminal for ground reference.
ADJ	PWM Signal Input – Connects to the internal reference, via an internal filter and gain resistor, allowing a dynamic output voltage adjustment $\pm 15\%$ in corresponding to a varying duty cycle. 50% duty cycle yields a nominal output set via the FB pin (See Note) or ADJ input voltage range from 0.9V to 1.5V DC
OUT	Output voltage is adjustable up to 25V (maximum).

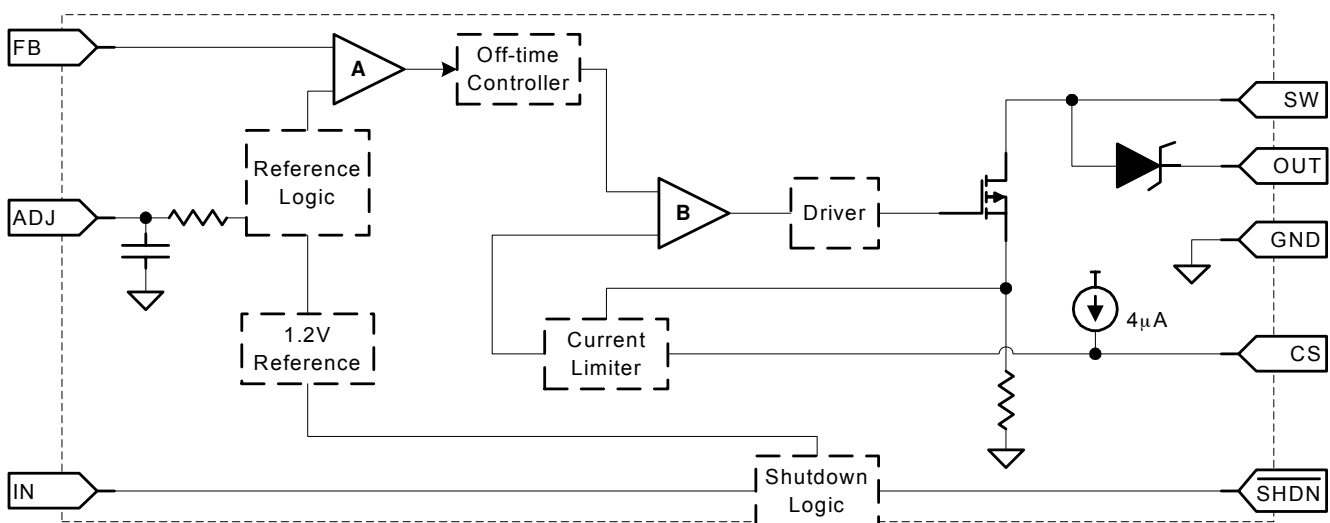
ELECTRICAL CHARACTERISTICS

Unless otherwise specified, the following specifications apply over the operating ambient temperature $0^{\circ}\text{C} \leq T_A \leq 70^{\circ}\text{C}$ except where otherwise noted and the following test conditions: $V_{IN} = 3.0\text{V}$, $V_{ADJ} = 0\text{V}$, $\text{SHDN} = V_{IN}$, $V_{FB} = 1.0\text{V}$, Pin 8 = (not connected), Pin 1 = (+5V through 39.2 Ω).

Parameter	Symbol	Test Conditions	LX1742			Units
			Min	Typ	Max	
Operating Voltage	V_{IN}		1.6		6.0	V
Minimum Start-up Voltage	V_{SU}	$T_A = +25^{\circ}\text{C}$			1.6	V
Start-up Voltage Temperature Coefficient	k_{VST}	Guaranteed: not tested		-2		mV/ $^{\circ}\text{C}$
Quiescent Current	I_Q	Not Switching		80	100	μA
		$V_{SHDN} < 0.4\text{V}$		0.5	1.0	μA
FB Threshold Voltage	V_{FB}	$V_{ADJ} = \text{GND}$	1.175	1.200	1.225	V
FB Input Bias Current	I_{FB}	Switching mode	0		200	nA
ADJ Input Voltage Range ¹	V_{ADJ}		0		$V_{IN} - 100\text{mV}$	V
ADJ Input Bias Current	I_{ADJ}	$V_{ADJ} = V_{FB} = 1.20\text{V}$	0		200	nA
Shutdown Input Bias Current	I_{SHDN}	$\text{SHDN} = \text{GND}$	-50		50	nA
Shutdown High Input Voltage	V_{SHDN}	$V_{IN} = 2\text{V}$	1.6			V
Shutdown Low Input Voltage	V_{SHDN}	$V_{IN} = 2\text{V}$			0.4	V
Current Sense Bias Current	I_{CS}		2.0	4.0	6.0	μA
Internal NFET On-resistance	$R_{DS(ON)}$	$T_A = +25^{\circ}\text{C}$; $I_{SW} = 10\text{mA}$; $V_{FB} = 1\text{V}$		1.1		Ω
Switch Pin Leakage Current	I_{LEAK}	$V_{SW} = 25\text{V}$		0.23		μA
Switch Off-Time	t_{OFF}	$V_{FB} = 1\text{V}$		300		ns
Diode Forward Voltage	V_F	$T_A = +25^{\circ}\text{C}$; $I_F = 150\text{mA}$		1.0		V
Diode Reverse Current	I_R	$T_A = +25^{\circ}\text{C}$; $V_R = 25\text{V}$		1.5		μA

Notes:

- When using a DC source to adjust V_{OUT} , the recommended V_{ADJ} (range) is 0.9V to 1.50V: see figure 9.
- Guaranteed typical value (not tested) @ $T_A = 25^{\circ}\text{C}$ (see section "Inductor Selection & Current Limit Programming").

SIMPLIFIED BLOCK DIAGRAM


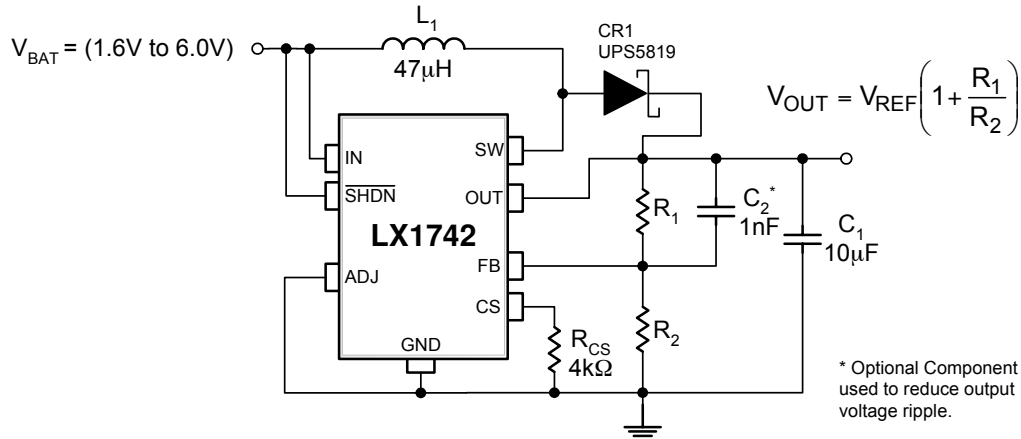
APPLICATION CIRCUITS
Typical LCD Bias Applications


Figure 1 – Circuit Showing Fixed Output Voltage Operation Using an External Schottky Diode Switch (CR1).

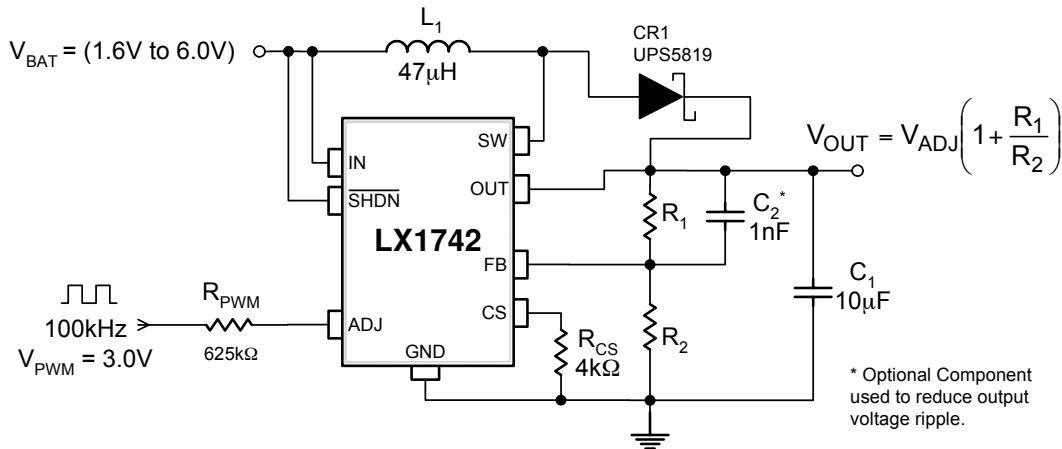


Figure 2 – Circuit Showing Dynamic Output Voltage Operation Via PWM Input Using an External Schottky Diode Switch (CR1).

Note: An in-series R_{PWM} will attenuate the PWM amplitude to the proper signal level at the ADJ pin. With the R_{PWM} value shown, a PWM signal having a duty of 30% to 50% will generate 0.9V to 1.5V at the ADJ pin.

APPLICATION CIRCUITS (CONTINUED)

Typical LCD Bias Applications (Cont)

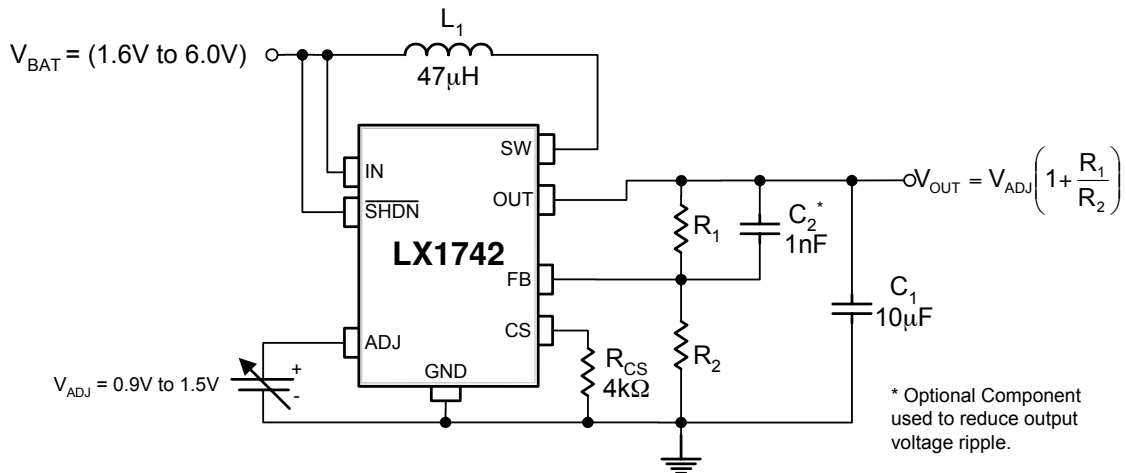


Figure 3 – Circuit Showing Dynamic Output Voltage Operation Via Analog Voltage Input and Using the Internal Diode Switch (Optional).

APPLICATION INFORMATION
FUNCTIONAL DESCRIPTION

The LX1742 is a Pulse Frequency Modulated (PFM) boost converter that is optimized for large step up voltage applications like LCD biasing. It operates in a pseudo-hysteretic mode with a fixed switch “off time” of 300ns. Converter switching is enabled when the feedback voltage, V_{FB} , falls below the 1.20V reference or VADJ (see Block Diagram). When this occurs, comparator A activates the off-time controller. The off-time controller and the current limiting circuits activate comparator B and toggles the output driver circuit. The output is switched “on”, and remains “on”, until the inductor current ramps up to the peak current level. This current level is set via the external R_{CS} resistor and monitored through the CS and SRC inputs.

The load is powered from energy stored in the output capacitor during the inductor charging cycle. Once the peak inductor current value is achieved, the driver output is turned off (off-time is typically 300ns) allowing a portion of the energy stored in the inductor to be delivered to the load. This causes the output voltage to continue to rise at the input to the feedback circuit (i.e., comparator A). If the voltage at the FB input is still less than 1.20V at the end of the off-time period, the output switches the internal FET “on” and the inductor charging cycle repeats until V_{FB} is greater than the internal reference. Typical converter switching behavior is shown in Figure 11.

The application of an external voltage source at the ADJ pin allows for output voltage adjustment over a typical range of approximately $\pm 15\%$. The designer can select one of two possible methods. One option is to vary the reference voltage directly at the ADJ pin by applying a DC voltage from 0.9 to 1.5V. The second option is to connect a PWM logic signal to the ADJ pin (e.g., see Figure 2). The LX1742 includes an internal 50pF capacitor to ground that works with an external resistor to create a low-pass filter (i.e., filter out the AC component of a pulse width modulated input of $f_{PWM} \geq 100\text{KHz}$).

The adjustment voltage level is selectable (with limited accuracy) by implementing the voltage divider created between the external series resistor and the internal 2.5M Ω resistor. If the DC voltage at the ADJ pin drops below 0.6V, the device will revert to the internal reference voltage level of 1.20V. A typical adjustment curve is shown in Figure 9 (see section titled: Characteristic Curves). Disabling the LX1742 is achieved by driving the SHDN pin with a low-level logic signal thus reducing the device power consumption to less than 1 μA .

OUTPUT VOLTAGE PROGRAMMING

Selecting the appropriate values for R1 and R2 in the voltage divider connected to the feedback pin programs the output voltage. Using a value between 40K Ω and 75K Ω for R2 works well in most applications. R1 can be determined by the following equation (where $V_{REF} = 1.29\text{V}$ nominal):

$$R1 = R2 \times \frac{(V_{OUT} - V_{REF})}{V_{REF}}$$

DESIGN EXAMPLE:

Let R2 equal 72K and the required VOUT equal to 18V.

$$R1 = 72\text{K}\Omega \times \frac{(18\text{V} - 1.20\text{V})}{1.20\text{V}} = 1.1\text{M}\Omega$$

INDUCTOR SELECTION AND CURRENT LIMIT PROGRAMMING

Setting the level of peak inductor current to approximately 2X the expected maximum DC input current will minimize the inductor size, the input ripple current, and the output ripple voltage. The designer is encouraged to use inductors that will not saturate at the peak inductor current level. An inductor value of 47 μH is recommended. Choosing a lower value emphasizes peak current overshoot while choosing a higher value emphasizes output ripple voltage. The peak switch current is defined using a resistor placed between the CS terminal and ground and the I_{PEAK} equation is:

$$I_{PEAK} = I_{MIN} + \left(\frac{V_{IN}}{L} \right) t_D + (I_{SCALE}) R_{CS}$$

The maximum I_{PEAK} value is limited by the I_{SRC} value (max. = 0.8A $_{RMS}$). The minimum I_{PEAK} value is defined when R_{CS} is zero. A typical value for the minimum peak current (I_{MIN}) at 25 $^{\circ}\text{C}$ is 104mA. The parameter t_D is related to internal operation of the device. A typical value at 25 $^{\circ}\text{C}$ is 800ns. A typical value of I_{SCALE} at 25 $^{\circ}\text{C}$ is 22mA per K Ω . All of these parameters have an effect on the final I_{PEAK} value.

DESIGN EXAMPLE:

Determine I_{PEAK} where V_{IN} equals 3.0V and R_{CS} equals 4.02K Ω using nominal values for all other parameters.

$$I_{PEAK} = 104\text{mA} + \left(\frac{3.0\text{V}}{47\mu\text{H}} \right) \times 800\text{ns} + \left(\frac{22\text{mA}}{\text{K}\Omega} \right) \times 4.02\text{K}\Omega$$

The result of this example yields a nominal I_{PEAK} equal to 243.5mA.

APPLICATION INFORMATION (CONTINUED)
OUTPUT RIPPLE CAPACITOR SELECTION

Output voltage ripple is a function of the inductor value (L), the output capacitor value (C_{OUT}), the peak switch current setting (I_{PEAK}), the load current (I_{OUT}), the input voltage (V_{IN}) and the output voltage (V_{OUT}) for a this boost converter regulation scheme. When the switch is first turned on, the peak-to-peak voltage ripple is a function of the output droop (as the inductor current charges to I_{PEAK}), the feedback transition error (i.e., typically 10mV), and the output overshoot (when the stored energy in the inductor is delivered to the load at the end of the charging cycle). Therefore the total ripple voltage is

$$V_{RIPPLE} = \Delta V_{DROOP} + \Delta V_{OVERSHOOT} + 10mV$$

The initial droop can be estimated as follows where the 1.2 value in the denominator is an estimate of the typical voltage drop across the inductor and the internal FET's R_{DS_ON} :

$$\Delta V_{DROOP} = \frac{\left(\frac{L}{C_{OUT}}\right) \times (I_{PK} \times I_{OUT})}{(V_{IN} - 1.2)}$$

The output overshoot can be estimated as follows where the 0.5 value in the denominator is an estimate of the voltage drop across the diode:

$$\Delta V_{OVERSHOOT} = \frac{\frac{1}{2} \times \left(\frac{L}{C_{OUT}}\right) \times (I_{PK} - I_{OUT})^2}{(V_{OUT} + 0.5 - V_{IN})}$$

DESIGN EXAMPLE:

Determine the V_{RIPPLE} where I_{PK} equals 200mA, I_{OUT} equals 35mA, L equals 47 μ H, C_{OUT} equals 4.7 μ F, V_{IN} equals 3.0V, and V_{OUT} equals 18.0V:

$$\Delta V_{DROOP} = \frac{\left(\frac{47\mu H}{4.7\mu F}\right) \times (200mA \times 35mA)}{(3.0 - 1.2)} = 38mV$$

$$\Delta V_{OVERSHOOT} = \frac{\frac{1}{2} \times \left(\frac{47\mu H}{4.7\mu F}\right) \times (200mA - 35mA)^2}{(18.0 + 0.5 - 3.0)} = 9.4mV$$

Therefore, for C_{OUT} equals 4.7 μ F:

$$V_{RIPPLE} = 38mV + 9.4mV + 10mV = 57.4mV$$

Increasing the output capacitor value results in the reduction of the output voltage ripple voltage. Low ESR capacitors are recommended to reduce ripple caused by the switching current. Multi-layer ceramic capacitors with X5R or X7R dielectric are a superior choice featuring small size, very low ESR, and a temperature stable dielectric. Low ESR electrolytic capacitors such as solid tantalum or OS-CON types are also acceptable. Moreover, adding a capacitor from the output to the feedback pin (C2) allows the internal feedback circuitry to respond faster which further minimizes output voltage ripple and reduces noise coupling into the high impedance feedback input.

DIODE SELECTION

A Schottky diode is recommended for most applications (e.g. Microsemi UPS5819). The low forward voltage drop and fast recovery time associated with this type of device supports the switching demands associated with this circuit topology. The designer is encouraged to consider the diode's average and peak current ratings with respect to the application's output and peak inductor current requirements. Further, the diode's reverse breakdown voltage characteristic must be capable of withstanding a negative voltage transition that is greater than V_{OUT} .

The LX1742 has a built in diode that may be used instead of an external device. Using this internal diode reduces system cost however, overall efficiency decreases. The electrical connections corresponding to use of the internal diode are shown in Figure 3. In this configuration, the inductor is connected between the input source and the SW pin (1). The output is taken directly from OUT pin (8).

PCB LAYOUT

The LX1742 produces high slew-rate voltage and current waveforms hence; the designer should take this into consideration when laying out the circuit. Minimizing trace lengths from the IC to the inductor, diode, input and output capacitors, and feedback connection (i.e., pin 3) are typical considerations. Moreover, the designer should maximize the DC input and output trace widths to accommodate peak current levels associated with this circuit.

EVALUATION BOARD
OVERVIEW

The LX1742 evaluation board is available from *Microsemi* for assessing overall circuit performance. The evaluation board, shown in Figure 5, is 3 by 3 inches (i.e., 7.6 X 7.6cm) square and factory calibrated to provide a nominal 18V output from a 1.6V to 6.0V input. Circuit designers can easily modify the output voltage and peak current to suit their particular application by adjusting the R2, R3, and R4 values accordingly. Further, other components are easily swapped out to promote design verification of any particular circuit application. Table 1 describes the evaluation board's electrical interface.

ELECTRICAL CONNECTIONS

The system level DC input voltage is applied to VIN. Connect the test load to VOUT. The Vin & GND terminal at J4 provides easy test point access. A similar connection is available for monitoring the output voltage via J5. The output voltage is adjusted by selecting appropriate values for R3 and R24. Further adjustment of the output voltage is achieved by applying either a DC voltage or a PWM-type signal to the ADJ input (J4).

The evaluation board accommodates both low frequency ($f < 100\text{KHz}$) and high frequency ($f > 100\text{KHz}$) PWM signals by connecting either JU1 or JU4 jumper position respectively. The ADJ pin is easily grounded for fixed voltage applications by inserting a jumper into the JU5 position. Table 2 provides a complete list of all jumper positions.

Removing the jumper from the /SHDN position disables the LX1742 by disconnecting pin 4 from VIN. The load is still capable of drawing current through the inductor & diode circuit path when the IC is in shutdown mode. Hence, VOUT during shutdown will be approximately VIN minus the inductor and diode forward voltage drop.

The LX1742 can achieve output voltages up to 25V. In certain applications, it is necessary to protect the load from excessive voltage excursions. The evaluation board provides a zener clamp diode (D1) for this purpose.

The LX1742 evaluation board offers a cost effective solution for evaluation of the LX1742. Table 3 provides the factory installed component list for the evaluation board and the board schematic is shown in Figure 4.

Table 1: Input and Output Pin Assignments

Name	Application Range	Description
VIN	0 to 6V	Main power supply input for evaluation board
Vin (J4)	0 to 6V	Connected to VIN (Alternate position or test point)
$\overline{\text{SHDN}}$ (J4)	0 to VIN	Pulled up to VCC on board (10K Ω), Ground to inhibit the LX1742.
ADJ (J4)	0 to VIN-100mV	Apply a DC input or PWM input to adjust the output voltage (note : see figure 9).
GND (J4)	0V	Circuit ground
GND	0V	Additional circuit ground connection point.
FDBK	0 to VIN	Apply a DC input or PWM input to adjust the output voltage.
GND2	0V	Additional circuit ground connection point.
VOUT	VIN to 25V	Output voltage test point. Programmed for 18V output, adjustable up to 25V.
SWITCH	N/A	Test point for LX1742 pin 1.
/SHDN	0 to VIN	A DC voltage above (below) 1.6V (0.4V) enables (disables) the LX172

Note: All pins are referenced to ground.

EVALUATION BOARD (CONTINUED)
Table 2: Jumper Pin Position Assignments

Jumper / Position		Function
VIN	n/a	Attach the primary input power form to this contact. Input power may also be applied to the pin marked Vin on J4.
VOUT	n/a	Use this contact to measure the circuit's output voltage at pin 8.
SWITCH	n/a	Use this contact to observe the switching waveform at the Schottky anode (i.e., LX1742 pin 1).
FDBK	n/a	Use this contact to measure the circuit's feedback voltage at pin 3.
GND / GND2	n/a	Use these contact to connect to circuit ground.
/SHDN	1 / 0	Inserting a jumper (1) enables the LX1742 by connecting pin 4 directly to VIN. Removing this jumper (0) disables the LX1742
JU3	1	Remove the factory installed jumper and insert a 4 ~6cm wire loop (<i>optional</i>) to observe the inductor current waveform using a current probe.
JU1	1 / 0 / 0	Use this position when adjusting the output with an external PWM that has a repetition rate less than 100KHz. Or when using a DC adjustment voltage.
JU4	0 / 1 / 0	Use this position when adjusting the output with an external PWM that has a repetition rate in excess of 100KHz.
JU5	0 / 0 / 1	Use this position to ground the ADJ (pin 5) when using the LX1742 in a fixed output voltage mode

Note: (1) = jumper installed; (0) = jumper not installed.

Table 3: Factory Installed Component List for the LX1742 Evaluation Board

Ref	Part Description
C1	CAPACITOR, 4.7 μ F, 1210, 35V
C2	CAPACITOR, 4.7 μ F, 1210, 35V
C3	CAPACITOR, 1000pF, 0805, 35V
C4	CAPACITOR, 2.2 μ F, 0603, 35V
C5 & C6	CAPACITOR, (SPARE); see note 1.
CR1	Microsemi UPS5819, SCHOTTKY, 1A, 40V, POWERMITE
L1	INDUCTOR, 47 μ H, 480mA, SMT
Q1	MMBT3904 TRANSISTOR, NPN, 40V, SOT-23
D1	BZX84C24, ZENER DIODE, TBD
R1	RESISTOR, 625K, 1/16W, 0805
R2, R5, R6	RESISTOR, 1.0K, 1/16W, 0805
R3	RESISTOR, 1.0M, 1/16W, 0805
R4	RESISTOR, 72K, 1/16W, 0805
R7	RESISTOR, 100K, 1/16W, 0805
U1	Microsemi LX1742CDU BOOST CONTROLLER; see note 2.

Notes

- Use these locations to insert additional input (C6) and/or output (C5) capacitance.
- The minimum part set for a working power supply consists of: C1, C2, CR1, L1, R2, R3, R4, U1.

EVALUATION BOARD (CONTINUED)

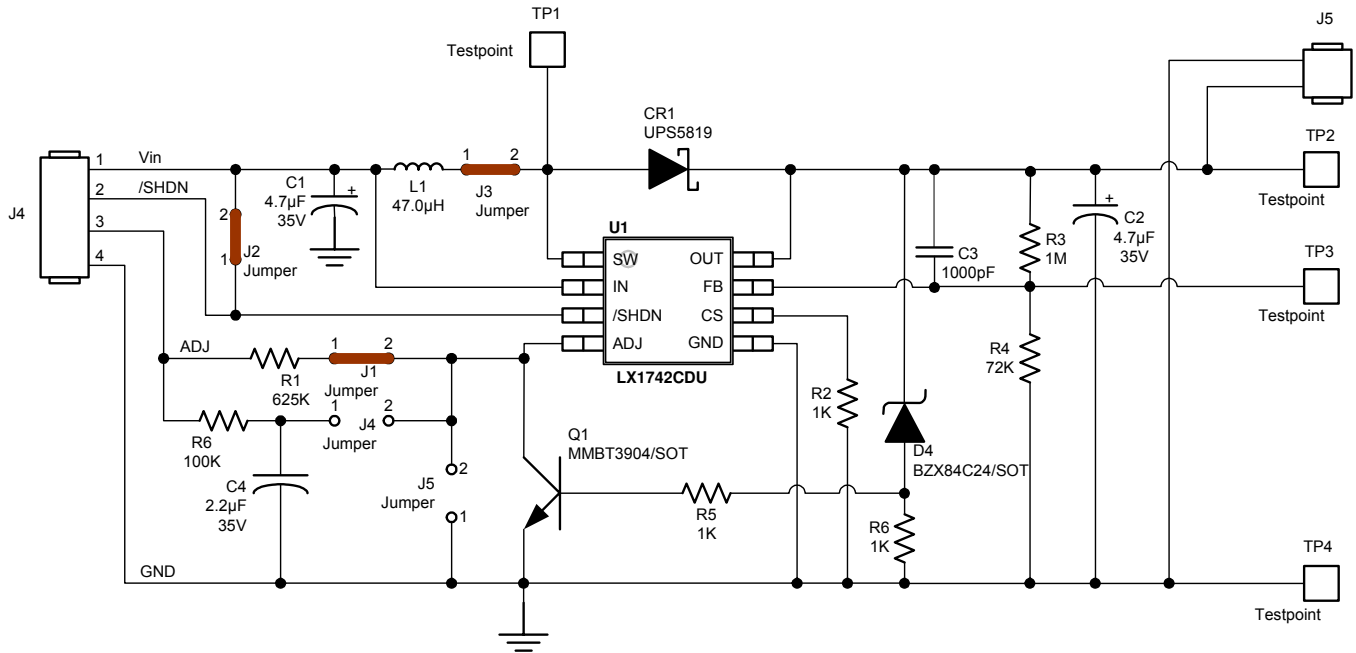


Figure 4 – LX1742 Boost Evaluation Board Schematic
Note: Factory installed jumper positions shown

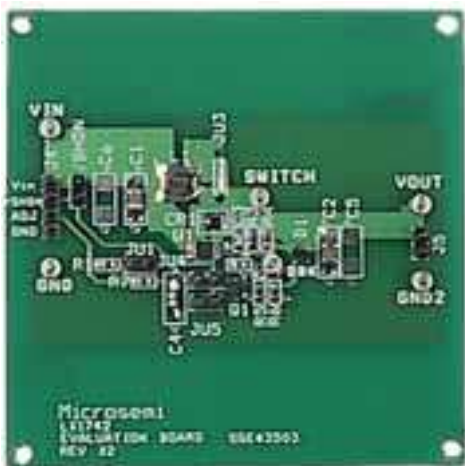


Figure 5 – LX1742 - LX1742 Circuit Evaluation Board

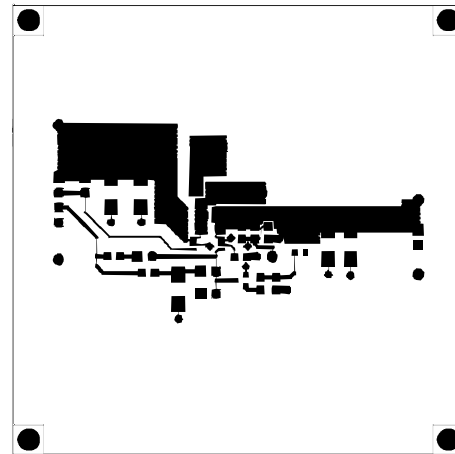


Figure 6 – LX1742 - Evaluation Board Trace Layout

EVALUATION BOARD (CONTINUED)

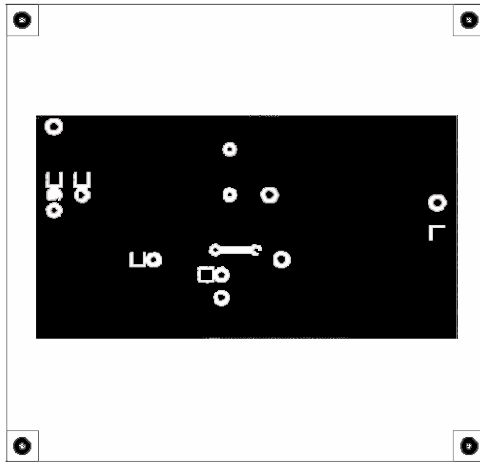


Figure 7 – LX1742 - Bottom Trace Layer

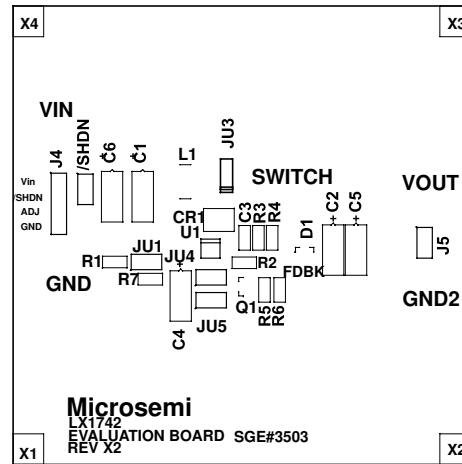
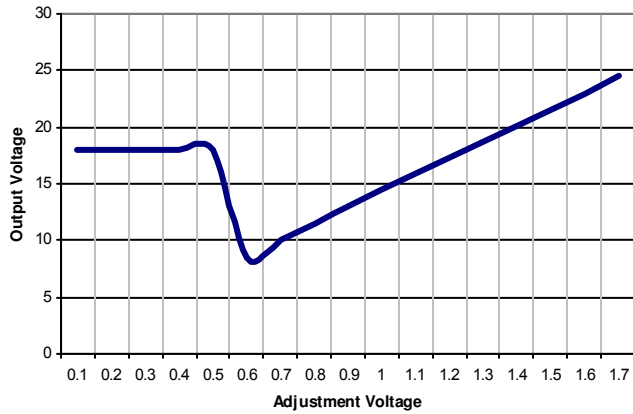
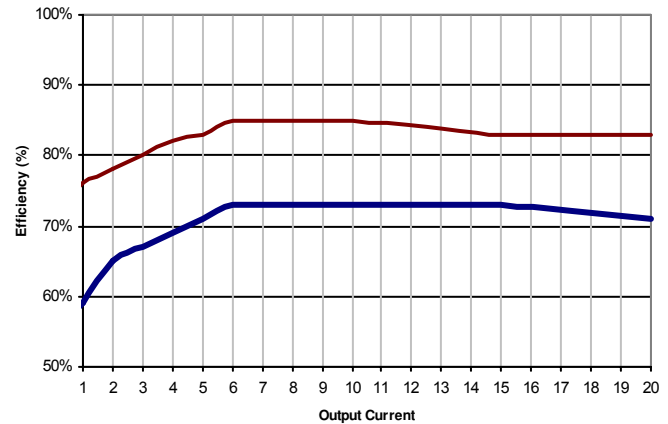
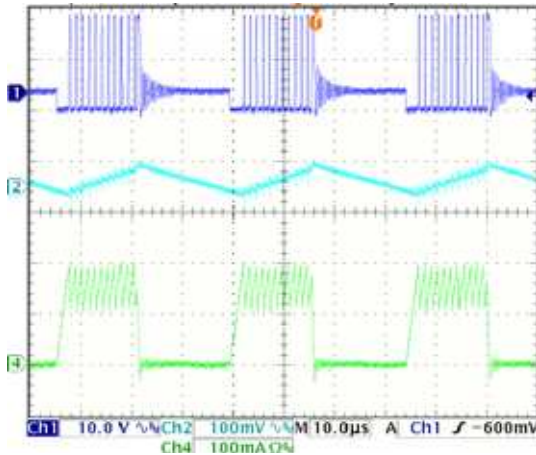


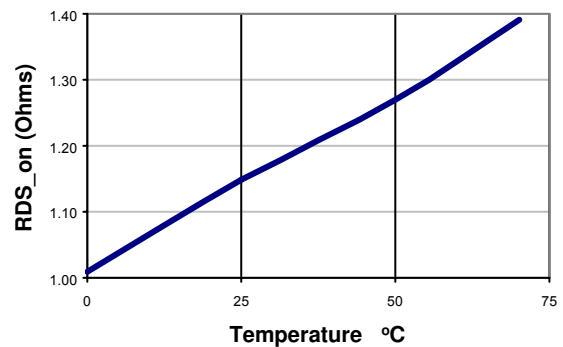
Figure 8 – LX1742 - Board Layout

CHARACTERISTIC CURVES

Figure 9 – Typical V_{OUT} versus V_{ADJ}

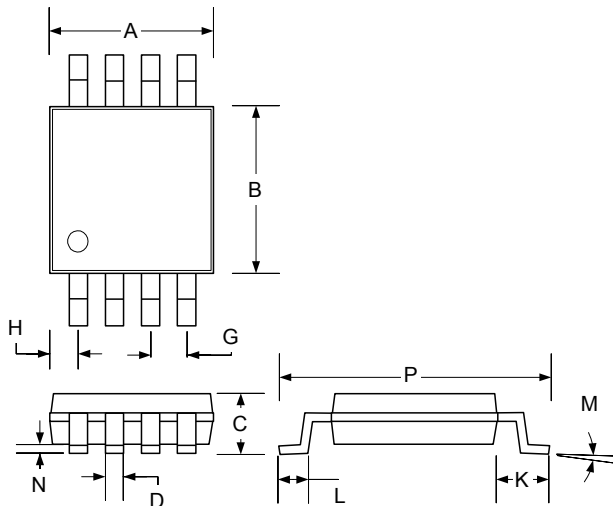
- 0 ~ 0.4V : LX1742 uses internal 1.2V reference.
- 0.5V ~ 0.7V : transition from internal to external reference.
- 0.8 to 1.5V : LX1742 defaults to external voltage reference.


Figure 10 – Efficiency vs. Output Current (mA)

Top: $V_{IN} = 3.6V$, $V_{OUT} = 5.2V$, $L1 = 47.0\mu H$
Bottom: $V_{IN} = 5.5V$, $V_{OUT} = 18.0V$, $L1 = 47.0\mu H$

Figure 11 – Typical switching waveforms:

 Ch1 – Switch voltage; Ch2 – Output voltage; Ch4 – Inductor current.
 ($V_{IN} = 3.6V$, $V_{OUT} = 18V$, $R_{LOAD} = 2K\Omega$)

Figure 12 – Typical $R_{DS(on)}$ vs. Temperature

 Condition: $V_{IN} = 3.0V$; $I_{SW} = 10mA$

PACKAGE DIMENSIONS
DU 8-Pin Miniature Shrink Outline Package (MSOP)


Dim	MILLIMETERS		INCHES	
	MIN	MAX	MIN	MAX
A	2.85	3.05	.112	.120
B	2.90	3.10	.114	.122
C	–	1.10	–	0.043
D	0.25	0.40	0.009	0.160
G	0.65 BSC		0.025 BSC	
H	0.38	0.64	0.015	0.025
J	0.13	0.18	0.005	0.007
K	0.95 BSC		0.037 BSC	
L	0.40	0.70	0.016	0.027
M	3°		3°	
N	0.05	0.15	0.002	0.006
P	4.75	5.05	0.187	0.198

NOTES

PRODUCTION DATA – Information contained in this document is proprietary to Microsemi and is current as of publication date. This document may not be modified in any way without the express written consent of Microsemi. Product processing does not necessarily include testing of all parameters. Microsemi reserves the right to change the configuration and performance of the product and to discontinue product at any time.