

NPN LOW POWER SILICON TRANSISTOR

Qualified per MIL-PRF-19500/181

DEVICES

2N718A

2N1613

2N1613L

LEVELS

JAN

JANTX

JANTXV

ABSOLUTE MAXIMUM RATINGS ($T_C = +25^\circ\text{C}$ unless otherwise noted)

Parameters / Test Conditions	Symbol	Min.	Unit
Collector-Emitter Voltage	V_{CEO}	30	Vdc
Collector-Base Voltage	V_{CBO}	75	Vdc
Emitter-Base Voltage	V_{EBO}	7.0	Vdc
Collector Current	I_C	500	mA
Total Power Dissipation @ $T_A = +25^\circ\text{C}$	P_T	0.5 0.8	W
Total Power Dissipation @ $T_C = +25^\circ\text{C}$	P_T	1.8 3.0	W
Operating & Storage Junction Temperature Range	T_J, T_{stg}	-65 to +200	$^\circ\text{C}$
Thermal Resistance, Junction-to-Case	$R_{\theta JC}$	97 58	$^\circ\text{C/W}$

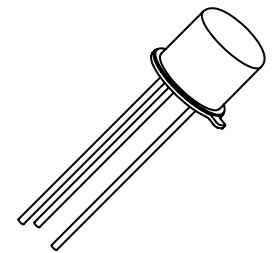

TO-18 (TO-206AA)
2N718A

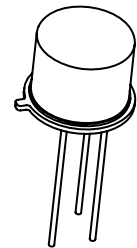

TO-39 (TO-205AD)
2N1613

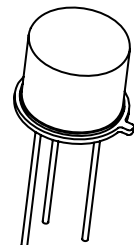

TO-5
2N1613L

- Derate linearly at 4.57 mW/ $^\circ\text{C}$ for 2N1613, L and 2.85mW/ $^\circ\text{C}$ for 2N718A for $T_A > +25^\circ\text{C}$
- Derate linearly at 17.2 mW/ $^\circ\text{C}$ for 2N1613, L and 10.3mW/ $^\circ\text{C}$ for 2N718A for $T_C > +25^\circ\text{C}$

ELECTRICAL CHARACTERISTICS ($T_A = +25^\circ\text{C}$, unless otherwise noted)

Parameters / Test Conditions	Symbol	Min.	Max.	Unit
OFF CHARACTERISTICS				
Collector-Emitter Breakdown Voltage $I_C = 100\mu\text{A}$	$V_{(BR)CEO}$	30		Vdc
Collector-Emitter Breakdown Voltage $I_C = 100\mu\text{A}$, $R_{BE} = 10\Omega$	$V_{(BR)CER}$	50		Vdc
Collector-Base Cutoff Current $V_{CB} = 60\text{Vdc}$ $V_{CB} = 75\text{Vdc}$	I_{CBO}		10 10	ηA μA
Emitter-Base Cutoff Current $V_{EB} = 5.0\text{Vdc}$ $V_{EB} = 7.0\text{Vdc}$	I_{EBO}		10 10	ηA dc μA

ELECTRICAL CHARACTERISTICS ($T_A = +25^{\circ}\text{C}$, unless otherwise noted)

Parameters / Test Conditions	Symbol	Min.	Max.	Unit
ON CHARACTERISTICS ⁽³⁾				
Forward-Current Transfer Ratio $I_C = 0.1\text{mA}_{dc}$, $V_{CE} = 10\text{V}_{dc}$ $I_C = 10\text{mA}_{dc}$, $V_{CE} = 10\text{V}_{dc}$ $I_C = 150\text{mA}_{dc}$, $V_{CE} = 10\text{V}_{dc}$ $I_C = 500\text{mA}_{dc}$, $V_{CE} = 10\text{V}_{dc}$	h_{FE}	20 35 40 20	120	
Collector-Emitter Saturation Voltage $I_C = 150\text{mA}_{dc}$, $I_B = 15\text{mA}_{dc}$	$V_{CE(sat)}$		1.5	Vdc
Base-Emitter Saturation Voltage $I_C = 150\text{mA}_{dc}$, $I_B = 15\text{mA}_{dc}$	$V_{BE(sat)}$		1.3	Vdc

DYNAMIC CHARACTERISTICS

Parameters / Test Conditions	Symbol	Min.	Max.	Unit
Magnitude of Small-Signal Forward Current Transfer Ratio $I_C = 50\text{mA}_{dc}$, $V_{CE} = 10\text{V}_{dc}$, $f = 20\text{MHz}$	$ h_{fe} $	3.0		
Small-Signal Forward Current Transfer Ratio $I_C = 1.0\text{mA}_{dc}$, $V_{CE} = 5\text{V}_{dc}$, $f = 1.0\text{kHz}$ $I_C = 5.0\text{mA}_{dc}$, $V_{CE} = 10\text{V}_{dc}$, $f = 1.0\text{kHz}$	h_{fe}	30 35	100 150	
Small-Signal Short Circuit Input Impedance $I_C = 5.0\text{mA}_{dc}$, $V_{CB} = 10\text{V}_{dc}$, $f = 1.0\text{kHz}$	h_{ib}	4.0	8.0	Ω
Small-Signal Short Circuit Output Admittance $I_C = 5.0\text{mA}_{dc}$, $V_{CB} = 10\text{V}_{dc}$, $f = 1.0\text{kHz}$	h_{ob}		1.0	$\eta\Omega$
Output Capacitance $V_{CB} = 10\text{V}_{dc}$, $I_E = 0$, $100\text{kHz} \leq f \leq 1.0\text{MHz}$	C_{obo}		25	pF

SWITCHING CHARACTERISTICS

Parameters / Test Conditions	Symbol	Min.	Max.	Unit
Turn-On Time & Turn-Off Time (See Figure 5 of MIL-PRF-19500/181)	$t_{on} + t_{off}$		30	ηs

(3) Pulse Test: Pulse Width = 300 μs , Duty Cycle $\leq 2.0\%$

PACKAGE DIMENSIONS

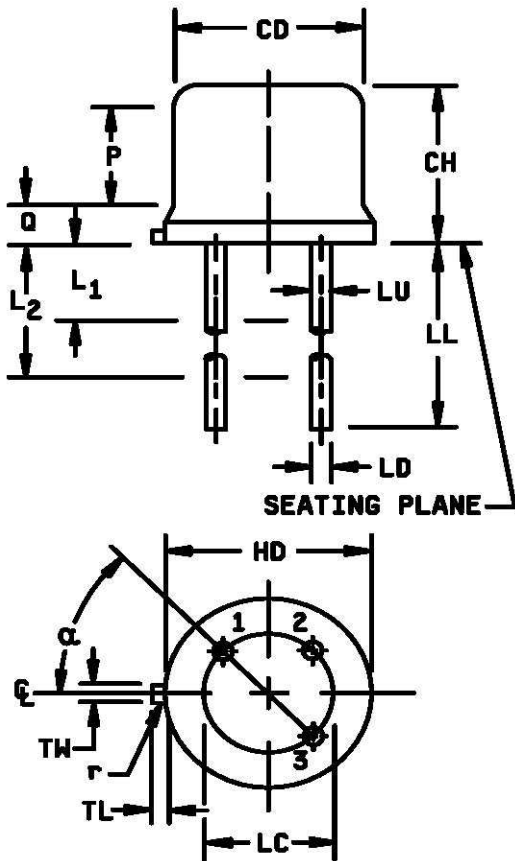

Symbol	Dimensions				Notes
	Inches		Millimeters		
	Min	Max	Min	Max	
CD	.178	.195	4.52	4.95	
CH	.170	.210	4.32	5.33	
HD	.209	.230	5.31	5.84	
LC	.100 TP		2.54 TP		5
LD	.016	.021	0.41	0.53	8, 9
LL	.500	.750	12.70	19.05	7, 9
LU	.016	.019	0.41	0.48	4, 8, 9
L ₁		.050		1.27	9
L ₂	.250		6.35		9
TL	.028	.048	0.71	1.22	5
TW	.036	.046	.91	1.17	
P	.100		2.54		3
Q		.030		0.76	6
R		.010		.025	
α	45° TP		45° TP		

NOTES:

- Dimensions are in inches.
- Millimeters are given for general information only.
- This zone is controlled for automatic handling. The variation in actual diameter within this zone shall not exceed .010 inch (0.254 mm).
- (Three leads) LU applies between L₁ and L₂. LD applies between L₂ and .5 inch (12.70 mm) from seating plane. Diameter is uncontrolled in L₁ and beyond .5 inch (12.70 mm) from seating plane.
- Measured from maximum diameter of the actual device.
- Details of outline in this zone optional.
- The collector shall be electrically connected to the case.
- Lead number 1 - emitter; lead number 2 - base; lead number 3 - collector.
- All three leads.
- In accordance with ANSI Y14.5M, diameters are equivalent to Φ x symbology.

FIGURE 1. Physical dimensions 2N718A (TO-18).

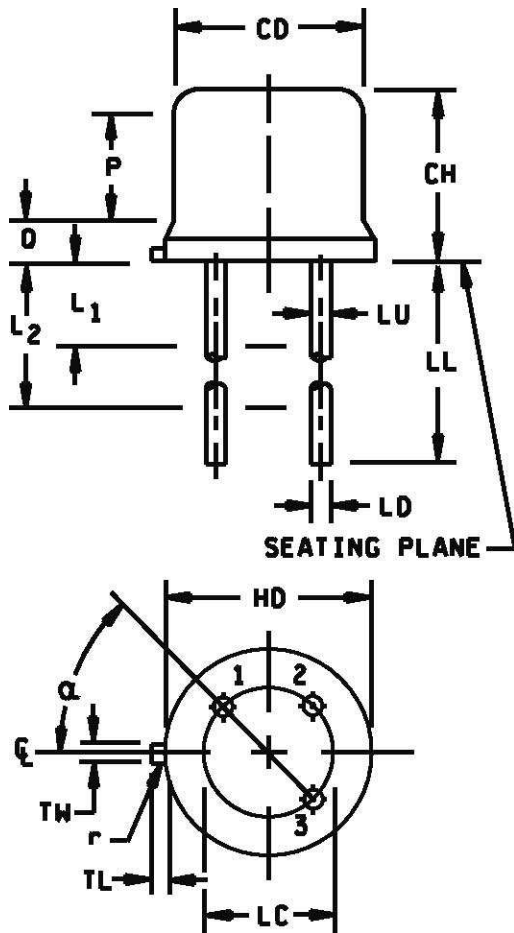

Symbol	Dimensions				Notes
	Inches		Millimeters		
	Min	Max	Min	Max	
CH	.240	.260	6.10	6.60	
LC	.200 TP		5.08 TP		7
LD	.016	.021	0.41	0.53	8, 9
LL	See notes 12 and 13				
LU	.016	.019	0.41	0.48	8, 9
L1		.050		1.27	8, 9
L2	.250		6.35		8, 9
HD	.335	.370	8.51	9.40	
CD	.305	.335	7.75	8.51	
P	.100		2.54		6
Q		.050		1.27	5
r		.010		0.25	
TL	.029	.045	0.74	1.14	4
TW	.028	.034	0.71	0.86	
α	45° TP		45° TP		7

NOTES:

- Dimensions are in inches.
- Metric equivalents are given for general information only.
- Beyond r (radius) maximum, TW shall be held for a minimum length of 0.011 inch (0.28 mm).
- TL measured from maximum HD.
- Outline in this zone is not controlled.
- CD shall not vary more than .010 inch (0.25 mm) in zone P. This zone is controlled for automatic handling.
- Leads at gauge plane .054 +.001, -.000 inch (1.37 +0.03, -0.000 mm) below seating plane shall be within .007 inch (0.18 mm) radius of true position (TP) at a maximum material condition (MMC) relative to the tab at MMC. The device may be measured by direct methods or by the gauging procedure.
- LU applies between L1 and L2. LU applies between L2 and LL minimum. Diameter is uncontrolled in L1 and beyond LL minimum.
- All three leads.
- The collector shall be electrically and mechanically connected to the case.
- r (radius) applies to both inside corners of tab.
- For transistor types 2N1613, dimension LL is .500 inch (12.70 mm) minimum, and .750 inch (19.05 mm) maximum.
- For transistor types 2N1613L, dimension LL is 1.500 inches (38.10 mm) minimum, and 1.750 inches (44.45 mm) maximum.
- Lead number 1 - emitter; lead number 2 - base; lead number 3 - collector.

FIGURE 2. Physical dimensions 2N1613 and 2N1613L (similar to TO-5 and TO-39).