

2N4427

**RF & MICROWAVE DISCRETE  
LOW POWER TRANSISTORS**

**Features**

- Silicon NPN, To-39 packaged VHF/UHF Transistor
- 
- 1 Watt Minimum Power Output @ 175 MHz
- 
- 500 MHz Current-Gain Bandwidth Product @ 50mA
- 
- Power Gain,  $G_{PE} = 10\text{dB (Min)}$  @ 175 MHz

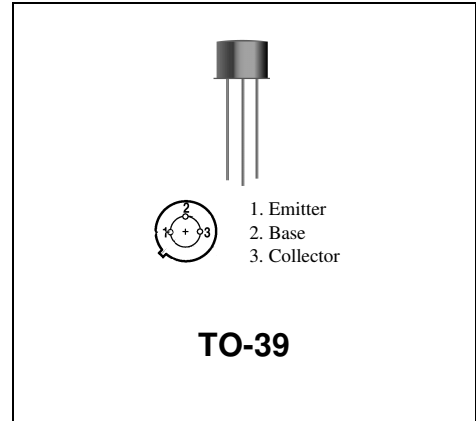

**DESCRIPTION:**

Silicon NPN transistor, designed for VHF and UHF equipment. Applications include amplifier; pre-driver, driver, and output stages. Also suitable for oscillator and frequency-multiplier functions.

**ABSOLUTE MAXIMUM RATINGS (T<sub>case</sub> = 25°C)**

Symbol	Parameter	Value	Unit
$V_{CEO}$	Collector-Emitter	20	Vdc
$V_{CBO}$	Collector-Base Voltage	40	Vdc
$V_{EBO}$	Emitter-Base Voltage	2.0	Vdc
$I_C$	Collector Current	400	mA

**Thermal Data**

$P_D$	Total Device Dissipation @ $T_A = 25^\circ\text{C}$ Derate above 25°C	1.0 5.71	Watts mW/°C
-------	--	-------------	----------------

**ELECTRICAL SPECIFICATIONS (T<sub>case</sub> = 25°C)**
**STATIC**
**(off)**

Symbol	Test Conditions	Value			Unit
		Min.	Typ.	Max.	
BVCER	Collector-Emitter Sustaining Voltage (I <sub>C</sub> = 5.0 mA <sub>dc</sub> , R <sub>BE</sub> = 10 ohms)	40	-	-	V <sub>dc</sub>
BVCEO	Collector-Emitter Sustaining Voltage (I <sub>C</sub> =5.0 mA <sub>dc</sub> , I <sub>B</sub> =0)	20	-	-	V <sub>dc</sub>
ICEO	Collector Cutoff Current (V <sub>CE</sub> = 12 V <sub>dc</sub> , I <sub>B</sub> = 0)	-	-	20	μA
ICEX	Collector Cutoff Current (V <sub>CE</sub> = 40 V <sub>dc</sub> , V <sub>BE</sub> = -1.5 V <sub>dc</sub> )	-	-	100	μA
IEBO	Emitter Cutoff Current (V <sub>EB</sub> = 2.0 V <sub>dc</sub> , I <sub>C</sub> = 0)	-	-	100	μA

**(on)**

HFE	DC Current Gain (I <sub>C</sub> = 100 mA <sub>dc</sub> , V <sub>CE</sub> = 5.0 V <sub>dc</sub> ) (I <sub>C</sub> = 360 mA <sub>dc</sub> , V <sub>CE</sub> = 5.0 V <sub>dc</sub> )	10	-	200	-
		5	-	-	-
VCE(sat)	Collector-Emitter Saturation Voltage (I <sub>C</sub> = 100 mA <sub>dc</sub> , I <sub>B</sub> = 20 mA <sub>dc</sub> )	-	-	0.5	V <sub>dc</sub>

**DYNAMIC**

Symbol	Test Conditions	Value			Unit
		Min.	Typ.	Max.	
f <sub>T</sub>	Current-Gain - Bandwidth Product (I <sub>C</sub> = 50 mA <sub>dc</sub> , V <sub>CE</sub> = 15 V <sub>dc</sub> , f = 200 MHz)	500	-	-	MHz
COB	Output Capacitance (V <sub>CB</sub> = 12 V <sub>dc</sub> , I <sub>E</sub> = 0, f = 1.0 MHz)	-	4.0	-	pF

**ELECTRICAL SPECIFICATIONS (T<sub>case</sub> = 25°C)**
**FUNCTIONAL**

Symbol	Test Conditions		Value			Unit
			Min.	Typ.	Max.	
G <sub>PE</sub>	Power Gain	Test Circuit-Figure 1 Pin = 0.1 W, VCE = 12Vdc f = 175 MHz	10	-	-	dB
P <sub>out</sub>	Output Power	Test Circuit-Figure 1 Pin = 0.1 W, VCE = 12Vdc f = 175 MHz	1.0	-	-	Watts
η <sub>c</sub>	Collector Efficiency	Test Circuit-Figure 1 Pin = 0.1 W, VCE = 12Vdc f = 175 MHz	45	-	-	%

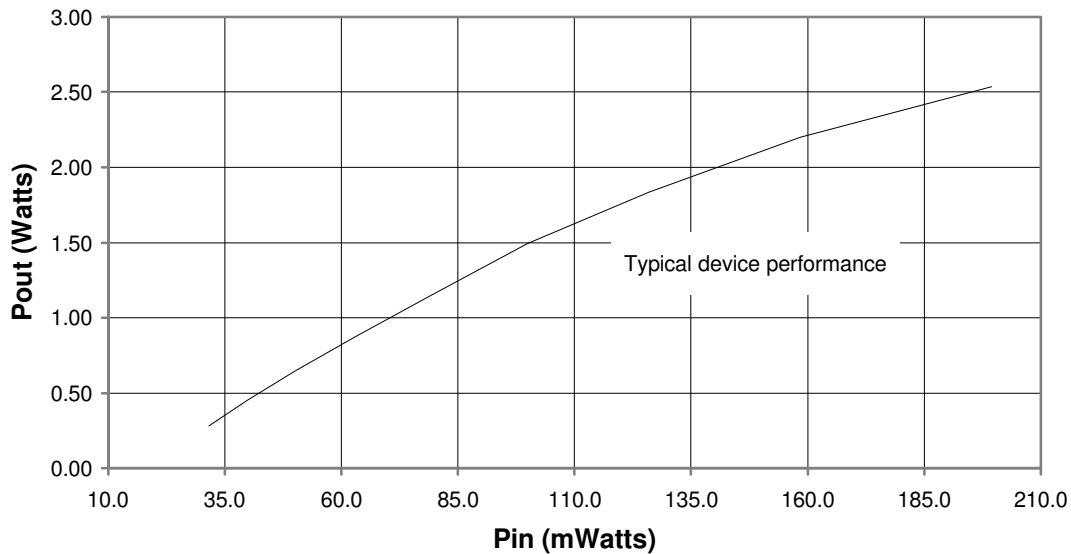

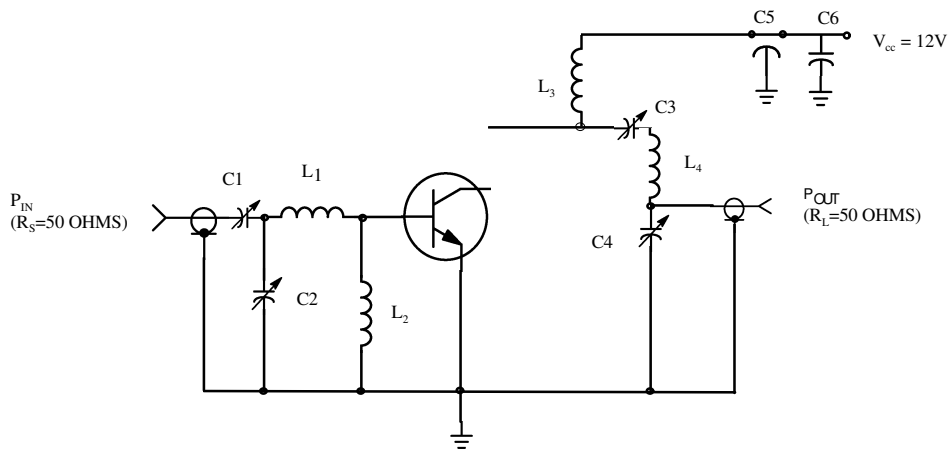

**Figure 1 - 175 MHz RF AMPLIFIER CIRCUIT FOR  $G_{PE}$ ,  $P_{OUT}$ , AND EFFICIENCY SPECIFICATIONS.**

L<sub>1</sub>: 2 TURNS No. 16 wire, 3/16" ID, 1/4" long

L<sub>3</sub>: 2 TURNS No. 16 wire, 1/4" ID, 1/4" long

Capacitor values in pF unless

L<sub>2</sub>: Ferrite choke, Z=450 ohms

L<sub>4</sub>: 4 TURNS No. 16 wire, 3/8" ID, 3/8" long

Tuning capacitors are air variable otherwise indicated.

## RF Low Power PA, LNA, and General Purpose Discrete Selector Guide

Packane	Device	Type	GPE Freq (MHz)	Pout (watts)	GPE (dB)	Efficiency (%)	GPE VCC	BVCEO	IC max (mA)
SO-8	MRF4427, R2	NPN	175	0.15	18	60	12	20	400
TO-39	2N4427	NPN	175	1	10	50	12	20	400
POWER MACRO	MRF553	NPN	175	1.5	11.5	60	12.5	16	500
POWER MACRO	MRF553T	NPN	175	1.5	11.5	50	12.5	16	500
TO-39	MRF607	NPN	175	1.75	11.5	50	12.5	16	330
TO-39	2N6255	NPN	175	3	7.8	50	12.5	18	1000
TO-72	2N5179	NPN	200		20	6	12	50	
MACRO X	MRF559	NPN	512	0.5	10	65	7.5	16	150
MACRO X	MRF559	NPN	512	0.5	13	60	12.5	16	150
TO-39	2N3866A	NPN	400	1	10	45	28	30	400
SO-8	MRF3866, R1, R2	NPN	400	1	10	45	28	30	400
POWER MACRO	MRF555	NPN	470	1.5	11	50	12.5	16	400
POWER MACRO	MRF555T	NPN	470	1.5	11	50	12.5	16	400
MACRO X	MRF559	NPN	870	0.5	6.5	70	7.5	16	150
MACRO X	MRF559	NPN	870	0.5	9.5	65	12.5	16	150
SO-8	MRF8372, R1, R2	NPN	870	0.75	8	55	12.5	16	200
POWER MACRO	MRF557	NPN	870	1.5	8	55	12.5	16	400
POWER MACRO	MRF557T	NPN	870	1.5	8	55	12.5	16	400

Packag	Device	Type	Freq (MHz)	NF	NF @ 100 (dB)	NF VCE	GN (dB)	Gu Max (dB)	Ftau (MHz)	Cob(pF)	BVCEO	IC max (mA)
TO-39	2N5109	NPN	200	3	10	15		12	1200	3.5	20	400
TO-39	MRF5943C	NPN	200	3.4	30	15		11.4	1000		30	400
SO-8	MRF5943, R1, R2	NPN	200	3.4	30	15		15	1300		30	400
TO-72	2N5179	NPN	200	4.5	1.5	6		17	900	1	12	50
TO-72	2N2857	NPN	300	5.5	50	6		13	1600	1	15	40
TO-39	MRF517	NPN	300	7.5	50	15		5.5	4600	3	25	150
TO-72	MRF904	NPN	450	1.5	5	6		11	4000	1	15	30
TO-72	2N6304	NPN	450	5	2	5		14	1400	1	15	50
MACRO T	BFR91	NPN	500	1.9	2	5	11	16.5	5000	1	12	35
MACRO T	BFR96	NPN	500	2	10	10		14.5	500	2.6	15	100
SO-8	MRF5812, R1, R2	NPN	500	2	50	10	15.5	17.8	5000		15	200
MACRO X	MRF581A	NPN	500	2	50	10	14	15	5000		15	200
Macro	BFR90	NPN	500	2.4	2	10	15	18	5000	1	15	30
TO-72	BFY90	NPN	500	2.5	2	5		20	1300		15	50
TO-72	MRF914	NPN	500	2.5	5	10		15	4500		12	40
MACRO X	MRF581	NPN	500	2.5	50	10	15	17.8	5000		16	200
TO-39	MRF586	NPN	500	3	90	15	11	14.5	4500	2.2	17	200
MACRO X	MRF951	NPN	1000	1.3	5	6	14	17	8000	0.45	10	100
MACRO X	MRF571	NPN	1000	1.5	10	6	10		8000	1	10	70
MACRO T	BFR91	NPN	1000	2.5	2	5	8	11	5000	1	12	35
MACRO T	BFR90	NPN	1000	3	2	10	10	12.5	5000	1	15	30
TO-39	MRF545	PNP						14	1400	2	70	400
TO-39	MRF544	NPN						13.5	1500		70	400

RF (Low Power PA / General Purpose) Selection Guide

RF (LNA / General Purpose) Selection Guide

### Low Cost RF Plastic Package Options

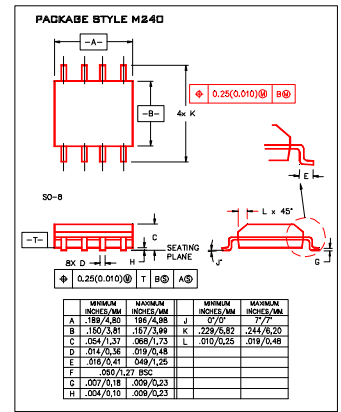
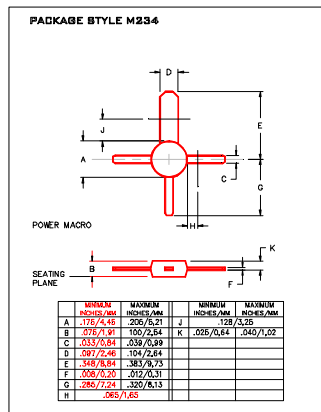
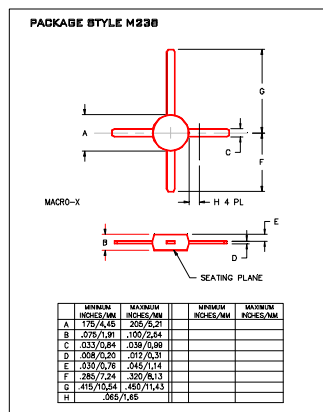
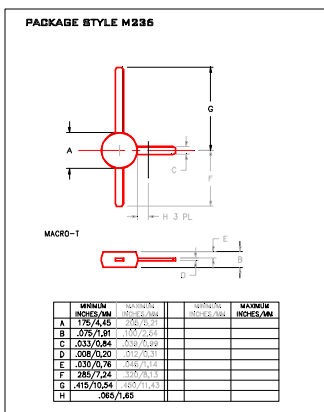

Macro T

Macro X

Power

SO-8

PACKAGE STYLE M246

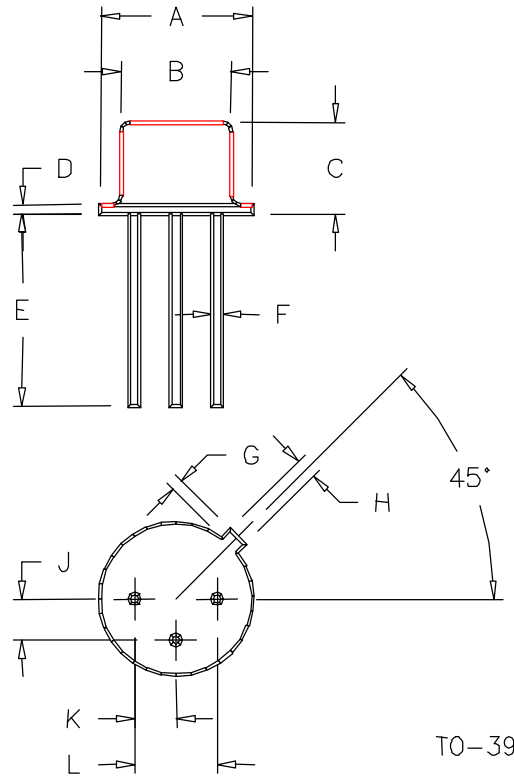

	MINIMUM INCHES/MM	MAXIMUM INCHES/MM		MINIMUM INCHES/MM	MAXIMUM INCHES/MM
A	.350/8,89	.370/9,40	J	.095/2,41	.105/2,67
B	.315/8,00	.335/8,51	K	.095/2,41	.105/2,67
C	.240/6,10	.260/6,60	L	.190/4,83	.210/5,33
D	.015/0,38	.045/1,14			
E	.500/12,70				
F	.016/0,41	.019/0,48			
G	.029/0,74	.040/1,02			
H	.028/0,71	.034/0,86			