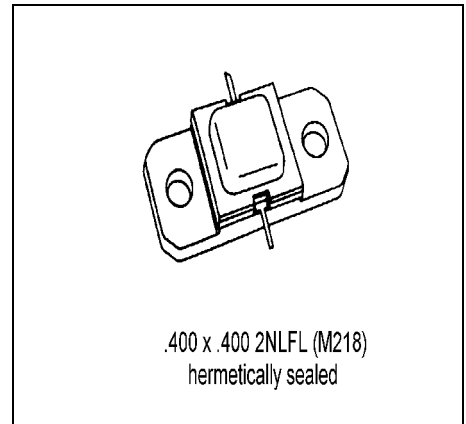
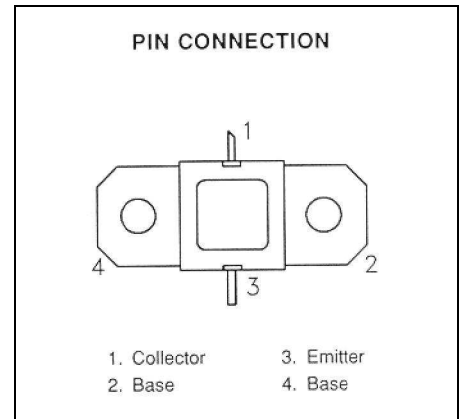

MS2554
**RF & MICROWAVE TRANSISTORS
 AVIONICS APPLICATIONS**
Features

- 1025 – 1150 MHz
- 50 VOLTS
- INPUT/OUTPUT MATCHING
- $P_{OUT} = 250$ WATTS
- $G_P = 6.2$ dB MINIMUM
- COMMON BASE CONFIGURATION

DESCRIPTION:

The MS2554 is a NPN bipolar transistor specifically designed for high peak pulse power applications such as DME/TACAN. This device is capable of withstanding a minimum 20:1 load VSWR at any phase angle under full rated conditions. Internal impedance matching provides consistent broadband performance.

ABSOLUTE MAXIMUM RATINGS (T_{case} = 25°C)

Symbol	Parameter	Value	Unit
P_{DISS}	Power Dissipation	600	W
I_C	Device Current	17.8	A
V_{CC}	Collector-Supply Voltage*	55	V
T_J	Junction Temperature	200	°C
T_{STG}	Storage Temperature	-65 to +200	°C

Thermal Data

$R_{TH(J-C)}$	Thermal Resistance Junction-case	0.20	°C/W
---------------	----------------------------------	------	------

ELECTRICAL SPECIFICATIONS (T_{case} = 25°C)
STATIC

Symbol	Test Conditions		Value			Unit
			Min.	Typ.	Max.	
BV_{CBO}	I_C = 15 mA	I_E = 0 mA	65	---	---	V
BV_{EBO}	I_E = 1 mA	I_C = 0 mA	3.5	---	---	V
BV_{CER}	I_C = 50 mA	R_{BE} = 10 Ω	65	---	---	V
I_{CES}	V_{CE} = 50 V		---	---	25	mA
HFE	V_{CE} = 5 V	I_C = 1 A	15	---	120	---

DYNAMIC

Symbol	Test Conditions			Value			Unit
				Min.	Typ.	Max.	
P_{OUT}	f = 1025 - 1150 MHz	P_{IN} = 90 W	V_{CC} = 50 V	250	---	---	W
η_C	f = 1025 - 1150 MHz	P_{IN} = 90 W	V_{CC} = 50 V	40	---	---	%
G_p	f = 1025 - 1150 MHz	P_{IN} = 90 W	V_{CC} = 50 V	6.2	---	---	dB
Condition	Pulse Width = 10uS Duty Cycle = 1%						

IMPEDANCE DATA

FREQ	Z _{IN} (Ω)	Z _{CL} (Ω)
1025 MHz	4.2 + j6.7	2.0 - j7.5
1090 MHz	4.0 + j3.5	2.5 - j7.5
1150 MHz	2.3 + j2.3	2.5 - j8.5

V_{CC} = 50V
P_{IN} = 60W

PACKAGE MECHANICAL DATA

