

MS2214

**RF & MICROWAVE TRANSISTORS
AVIONICS APPLICATIONS**

Features

- GOLD METALLIZATION
- EMITTER SITE BALLASTED
- Pout = 85 W MINIMUM
- Gp = 7.5 dB
- OVERLAY GEOMETRY
- METAL/CERAMIC HERMETIC PACKAGE
- LOW THERMAL RESISTANCE

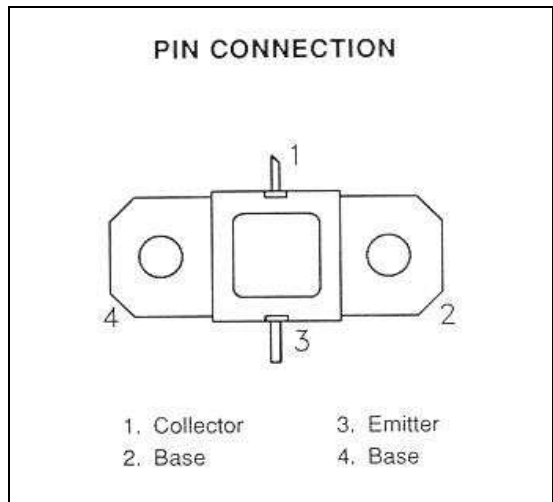
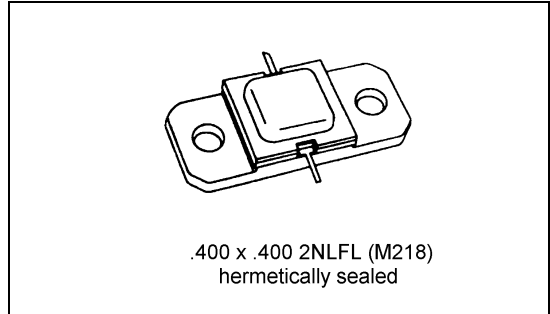

DESCRIPTION:

The MS2214 is a silicon NPN bipolar transistor designed for avionics applications with high duty cycle requirements. Gold metallization and emitter ballasting provides long term reliability under JTIDS and similar pulse formats.

ABSOLUTE MAXIMUM RATINGS (Tcase = 25°C)

Symbol	Parameter	Value	Unit
V _{CC}	Collector-Supply Voltage*	40	V
I _C	Device Current*	8.0	A
P _{DISS}	Power Dissipation*	300	W
T _J	Junction Temperature	+250	°C
T _{STG}	Storage Temperature	- 65 to + 200	°C

Thermal Data

R _{TH(i-c)}	Junction-Case Thermal Resistance*	0.75	°C/W
----------------------	-----------------------------------	------	------

* Applies only to rated RF operation.

ELECTRICAL SPECIFICATIONS (T_{case} = 25°C)

STATIC

Symbol	Test Conditions		Value			Unit
			Min.	Typ.	Max.	
BV_{CBO}	I_C = 25mA	I_E = 0 mA	55	----	----	V
BV_{CER}	I_C = 25 mA	R_{BE} = 10 Ω	55	----	----	V
BV_{EBO}	I_E = 10 mA	I_C = 0 mA	3.5	----	----	V
I_{CES}	V_{CE} = 35 V	V_{BE} = 0 V	----	----	20	mA
h_{FE}	V_{CE} = 5 V	I_C = 2A	20	----	200	----

DYNAMIC

Symbol	Test Conditions			Value			Unit
				Min.	Typ.	Max.	
P_{OUT}	f = 960 - 1215 MHz	P_{IN} = 15 W	V_{CC} = 35 V	85	----	----	W
η_C	f = 960 - 1215 MHz	P_{IN} = 15 W	V_{CC} = 35 V	40	----	----	%
G_P	f = 960 - 1215 MHz	P_{IN} = 15 W	V_{CC} = 35 V	7.5	----	----	dB
Note:	Pulse Format: 6.4 μS on 6.6 μS off, repeat for 3.3 ms. Duty Cycle: Burst 49.2%, overall 20.8%						

IMPEDANCE DATA:

FREQUENCY	Z _{in}	Z _{cl}
960 MHz	3.0 + j5.0	7.0 - j5.0
1090 MHz	5.5 + j5.5	3.7 - j1.8
1215 MHz	5.3 + j4.5	3.0 - j2.5

P_{in} = 15W V_{cc} = 35V

TEST CIRCUIT

Ref. Dwg. No. J-313119

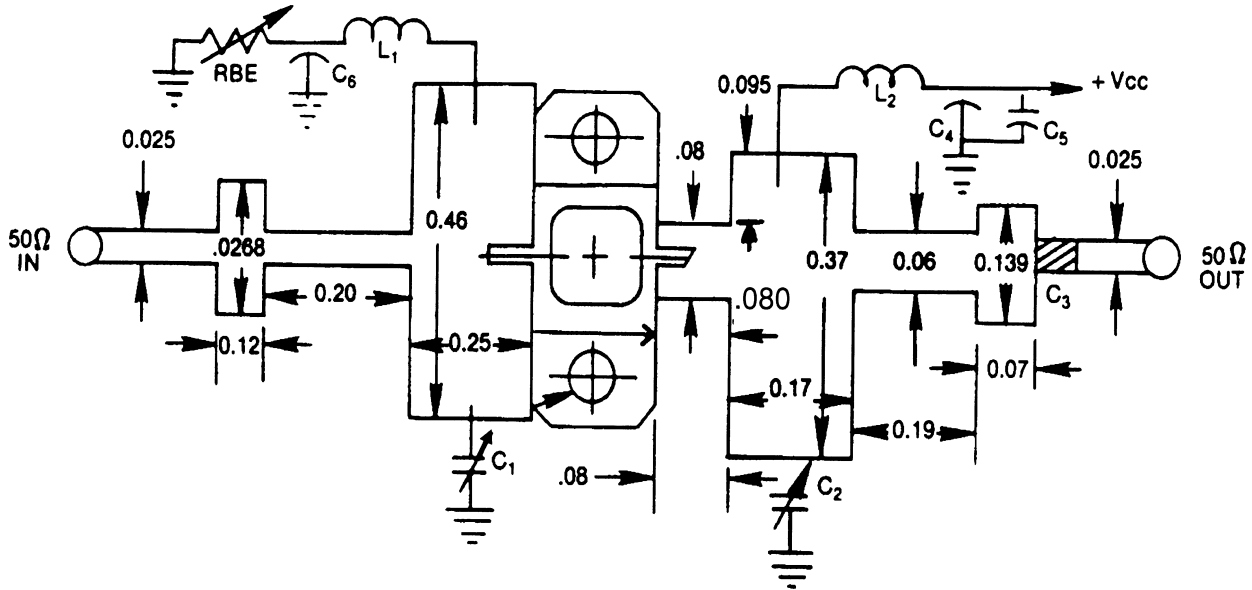

All dimensions are in inches.

Substrate material: .025 thick Al_2O_3 ($Er = 9.6$)

- C1 : 0.3—3.5 pF Variable Johanson Capacitor or Equiv.
- C2 : 0.3—3.5 pF Variable Johanson Capacitor or Equiv.
- C3 : 100 pF Chip Capacitor
- C4 : 1500 pF Erie RF Feedthrough, or Equiv.

- C5 : 100 MF, Electrolytic Capacitor, 50V
- C6 : 1500 pF Erie RF Feedthrough, or Equiv.
- L1 : No. 32 Wire, 4 Turns 1/16" I.D.
- L2 : No. 32 Wire, 4 Turns 1/16" I.D.

PACKAGE MECHANICAL DATA

PACKAGE STYLE M218

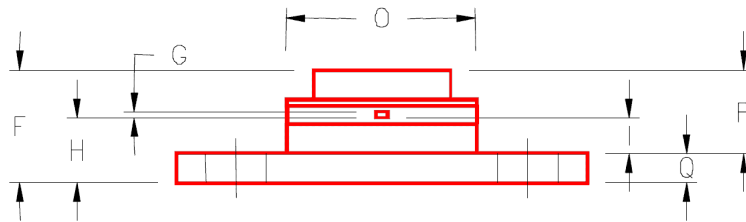
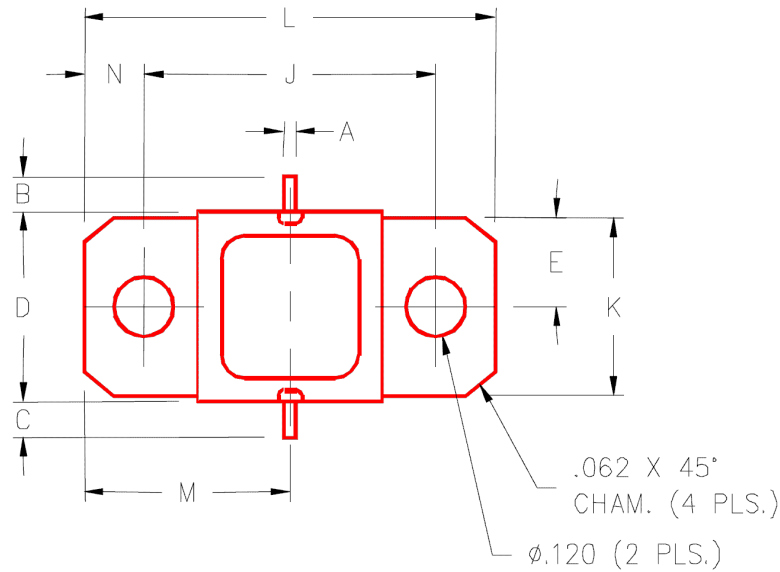

	MINIMUM INCHES/MM	MAXIMUM INCHES/MM		MINIMUM INCHES/MM	MAXIMUM INCHES/MM
A	.025/0,64		J	.650/16,51	
B	.100/2,54		K	.386/9,80	
C	.100/2,54		L	.900/22,86	
D	.395/10,03	.407/10,34	M	.450/11,43	
E	.193/4,90		N	.125/3,18	
F		.230/5,84	O	.405/10,29	
G	.004/0,10	.007/0,18	P		.170/4,32
H	.118/3,00	.131/3,33	Q	.062/1,58	
I	.063/1,60				