

Silicon Power Rectifier

1N3288-1N3297

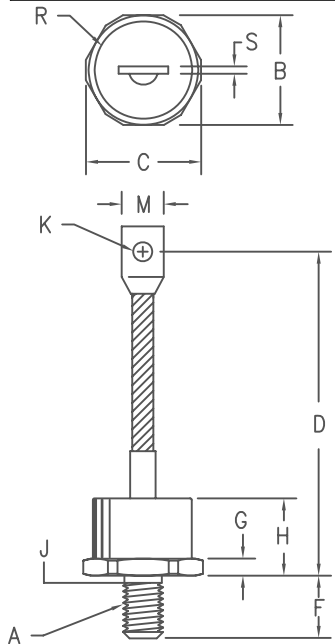

Notes:

1. 3/8-24 UNF-3A
2. Full threads within 2 1/2 threads
3. Standard polarity: Stud is Cathode
Reverse polarity: Stud is Anode

Dim.	Inches		Millimeter		Notes
	Minimum	Maximum	Minimum	Maximum	
A	---	---	---	---	1,3
B	1.040	1.060	26.67	26.92	
C	---	1.166	---	29.61	
D	4.30	4.65	109.22	118.11	
F	.610	.640	15.49	16.25	
G	.213	.233	5.41	5.66	
H	---	.745	---	18.92	
J	.344	.373	8.74	9.47	2
K	.276	.286	7.01	7.26	
M	.465	.670	11.81	17.02	
R	.625	.850	15.88	21.59	Dia
S	.050	.120	1.27	3.05	

D0205AA (D08)

Microsemi Catalog Number	Additional JEDEC Numbers			Peak Reverse Voltage
1N3288,S	1N411B	1N1396	1N2426	50V
	1N412B	1N1397	1N2427	100V
		1N1398	1N2428	150V
1N3289,S	1N413B	1N1399	1N2429	200V
			1N2430	250V
1N3290,S		1N1400	1N2431	300V
			1N2432	350V
1N3291,S		1N1401	1N2433	400V
1N3292,S,B		1N1402	1N2434	500V
1N3293,S		1N1403	1N2435	600V
1N3294,S				800V
1N3295,S				1000V
1N3296,S				1200V
1N3297,S				1400V

For Reverse Polarity, add R to the part number

- Glass Passivated Die
- 1600 Amps Surge Rating
- Glass to metal seal construction
- VRRM to 1400V

Electrical Characteristics

Average forward current	IF(AV) 100 Amps	TC = 144°C, Half Sine Wave, RθJC = 0.4°C/W 8.3ms, half sine, TJ = 200°C
Maximum surge current	IFSM 1600 Amps	
Max I ² t for fusing	I ² t 10700 A ² s	
Max peak forward voltage	VFM 1.20 Volts	IFM = 200A: TJ = 25°C*
Max peak reverse current	IRM 50 μA	VRRM, TJ = 25°C
Max peak reverse current	IRM 5 mA	VRRM, TJ = 150°C
Max Recommended Operating Frequency	7.5kHz	

*Pulse test: Pulse width 300 μsec. Duty cycle 2%

Thermal and Mechanical Characteristics

Storage temperature range	TSTG	-65°C to 200°C
Operating junction temp range	TJ	-65°C to 200°C
Maximum thermal resistance	RθJC	0.4°C/W Junction to Case
Mounting torque		80-100 inch pounds
Weight		2.75 ounces (78 grams) typical

1N3288-1N3297

Figure 1
Typical Forward Characteristics

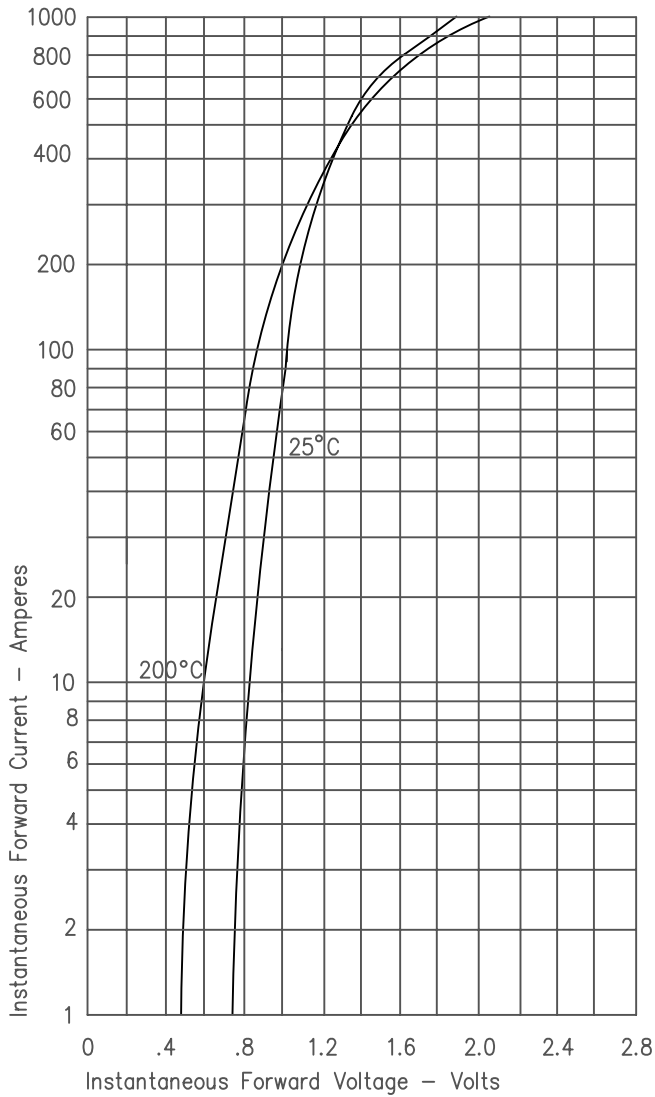

Figure 3
Forward Current Derating

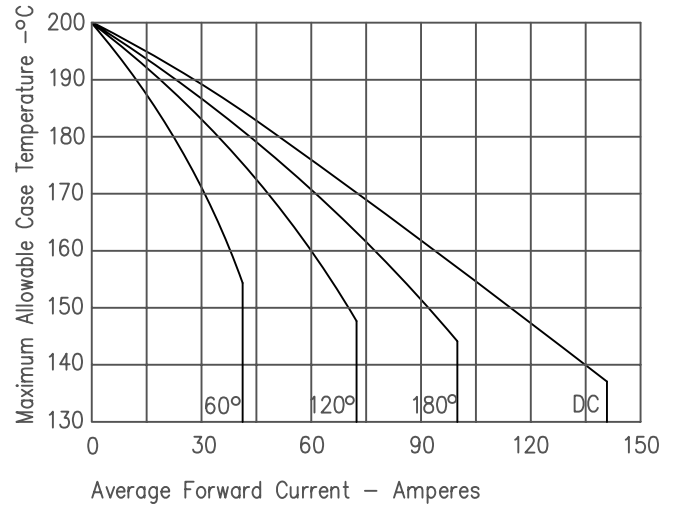

Figure 5
Transient Thermal Impedance

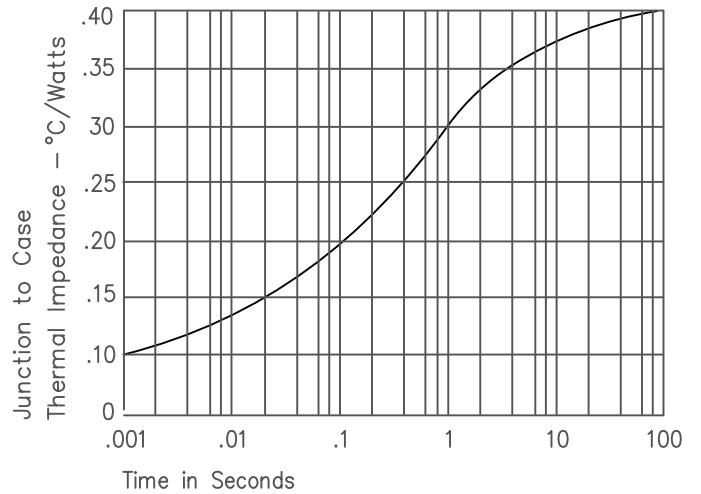

Figure 2
Typical Reverse Characteristics

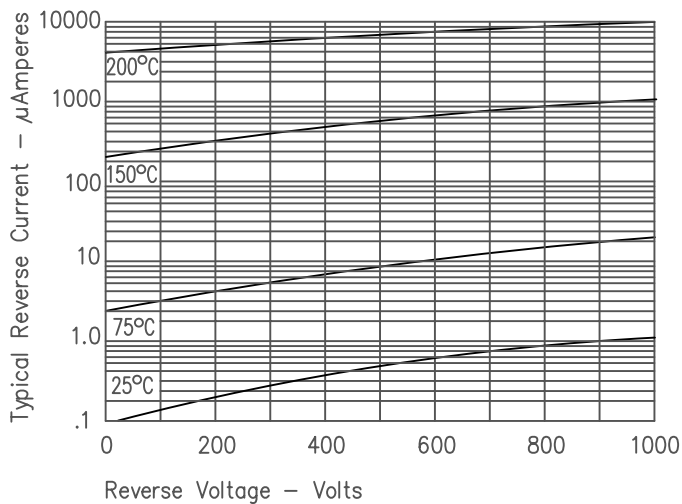

Figure 7
Maximum Nonrepetitive Surge Current

