

# EMI / RFI Toroid (1540 Series)

Chokes



## HIGH CURRENT TOROID INDUCTORS

- Ideal for EMI/RFI filtering applications
- Suitable for energy storage inductors for switching power supplies.
- High current
- Minimum .5" long leads, for P.C. board mounting.

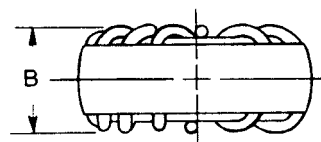
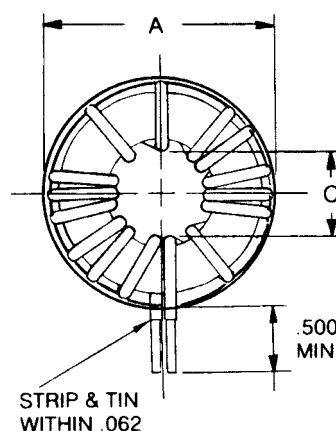

### Selection Table

Part No.	Inductance Ls +/- 15% @ 0A D.C. uH	Rated D.C. Amps	Minimum Inductance at rated D.C. uH	D.C. Resistance max. Ohms	D.C. Amps for 0.8 Ls	Dimensions			Typ. Lead Dia. (In.)
						A Max. (Inches)	B Max. (Inches)	C Min. (Inches)	
1540M01	10	11	5	0.008	7.5	0.875	0.437	0.187	0.064
1540M02	25	5.5	12	0.014	3.25	0.875	0.437	0.187	0.040
1540M03	125	2.75	70	0.12	1.5	0.875	0.437	0.187	0.020
1540M04	275	2	150	0.24	1.3	0.875	0.437	0.187	0.016
1540M05	450	1.5	250	0.49	0.8	0.875	0.437	0.187	0.012
1540M06	25	9	15	0.012	5.5	1.125	0.562	0.312	0.064
1540M07	75	5	40	0.04	3	1.125	0.562	0.312	0.036
1540M08	400	2.25	225	0.33	1.4	1.125	0.562	0.312	0.018
1540M09	800	1.75	475	0.64	1	1.125	0.562	0.312	0.015
1540M10	1000	1.5	575	0.98	0.9	1.125	0.562	0.312	0.012
1540M11	50	9.5	25	0.012	6	1.25	0.625	0.375	0.064
1540M12	150	4.75	85	0.046	2.5	1.25	0.625	0.375	0.036
1540M13	700	2.25	400	0.42	1.25	1.25	0.625	0.375	0.018
1540M14	1250	1.75	750	0.85	1	1.25	0.625	0.375	0.015
1540M15	1600	1.5	950	1.27	0.8	1.25	0.625	0.375	0.012
1540M16	125	7.75	65	0.032	5.25	1.812	0.750	0.750	0.064
1540M17	500	4	275	0.15	2.75	1.812	0.750	0.750	0.032
1540M18	1100	2.5	650	0.33	1.8	1.812	0.750	0.750	0.025
1540M19	2250	1.75	1350	0.92	1.3	1.812	0.750	0.750	0.080
1540M20	4500	1.25	2700	2.64	0.9	1.812	0.750	0.750	0.012
1540M21	250	8	125	0.041	4.75	2.125	0.937	0.625	0.062
1540M22	900	3.75	500	0.175	2	2.125	0.937	0.625	0.032
1540M23	1800	2.5	1000	0.55	1.4	2.125	0.937	0.625	0.023
1540M24	4000	1.75	2100	1.16	1.1	2.125	0.937	0.625	0.018
1540M25	8000	1	4500	3.34	0.7	2.125	0.937	0.625	0.012



**CANADA**  
Guelph, Ontario (519) 822-2960  
St. Laurent, Quebec (514) 343-9010  
**USA**  
Cheektowaga, NY (716) 630-7030

[www.hammondmfg.com](http://www.hammondmfg.com)



**EUROPE**  
Basingstoke, UK 01256 812812

**AUSTRALIA**  
Queenstown, Australia 61-8-8240-2244