

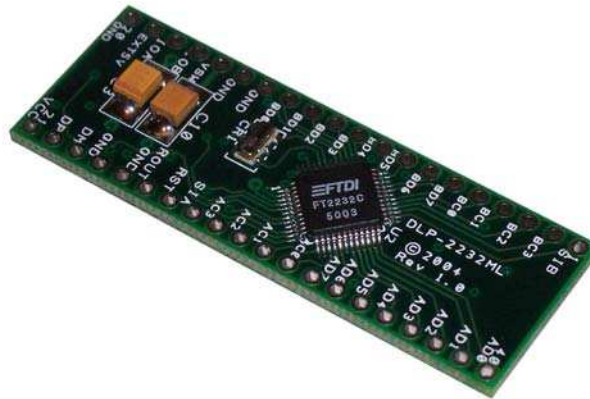

DLP-2232ML-G LOW-PROFILE USB MODULE

* Lead Free *



1.0 Introduction

The DLP-2232ML-G utilizes FTDI's third-generation USB UART/FIFO I.C., the FT2232D. This low-cost, RoHS compliant development tool features two Multi-Purpose UART/FIFO controllers that can be configured individually in several different modes.

In addition to the UART interface, FIFO interface, and Bit-Bang IO modes of the second-generation FT232BM and FT245BM devices, the FT2232D offers a variety of additional modes of operation including a Multi-Protocol Synchronous Serial Engine interface designed specifically for synchronous serial protocols such as JTAG and SPI bus.

The DLP-2232ML-G features a quality four-layer printed circuit board with a solid ground plane, an integral 93C56 EEPROM on board for easy OEM customization and a standard 40-pin, 0.6in wide footprint. Integral power control and on-board MOSFET power switch make the DLP-2232ML-G a perfect choice for USB bus-powered, high-power designs as well as self- and low-powered products.

NOTE: With the exception of the mechanical connectors, mechanical dimensions and the host connection interface signals, the DLP-2232ML-G and DLP-2232M-G are the same product. The supporting electronics for the USB connector are already on the DLP-2232ML-G board, just add a type B connector to your design and you're ready to go.

For a complete list of features and specifications please refer to the datasheet for the DLP-2232M-G.

2.0 Module Pin-Out

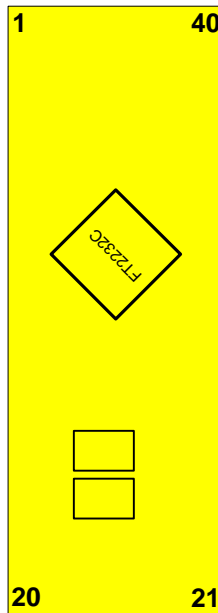
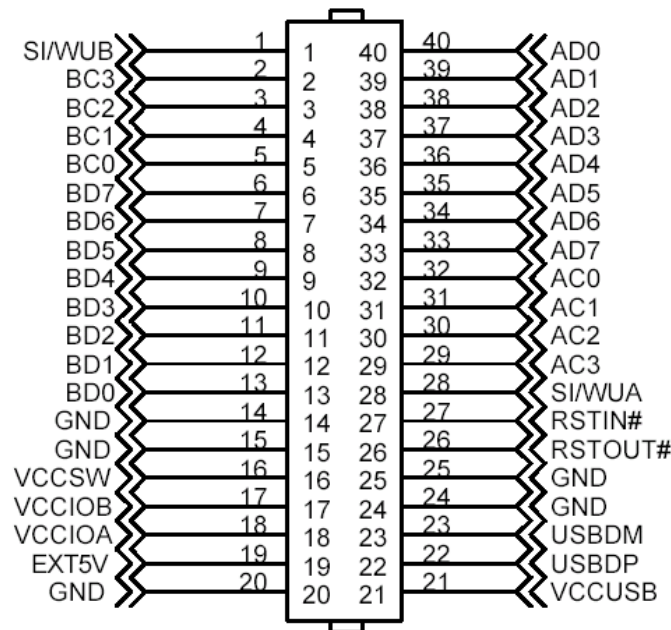

Figure 2. Pin-Out (40 Pin DIP Header)

2.1 Pin Definitions

Since the DLP-2232ML-G does not have a USB connector, the USBDM and USBDP signal lines are brought out on pins 23 and 22 as shown here.



With the exception of the 2 USB communications lines (USBDM and USBDP) and pin 20, the pinout for the DLP-2232ML-G is the same as the DLP-2232M-G module. Please refer to the datasheet for the DLP-2232M-G for a complete description of the pinout.

3.0 Mechanical Dimensions Inches (mm)

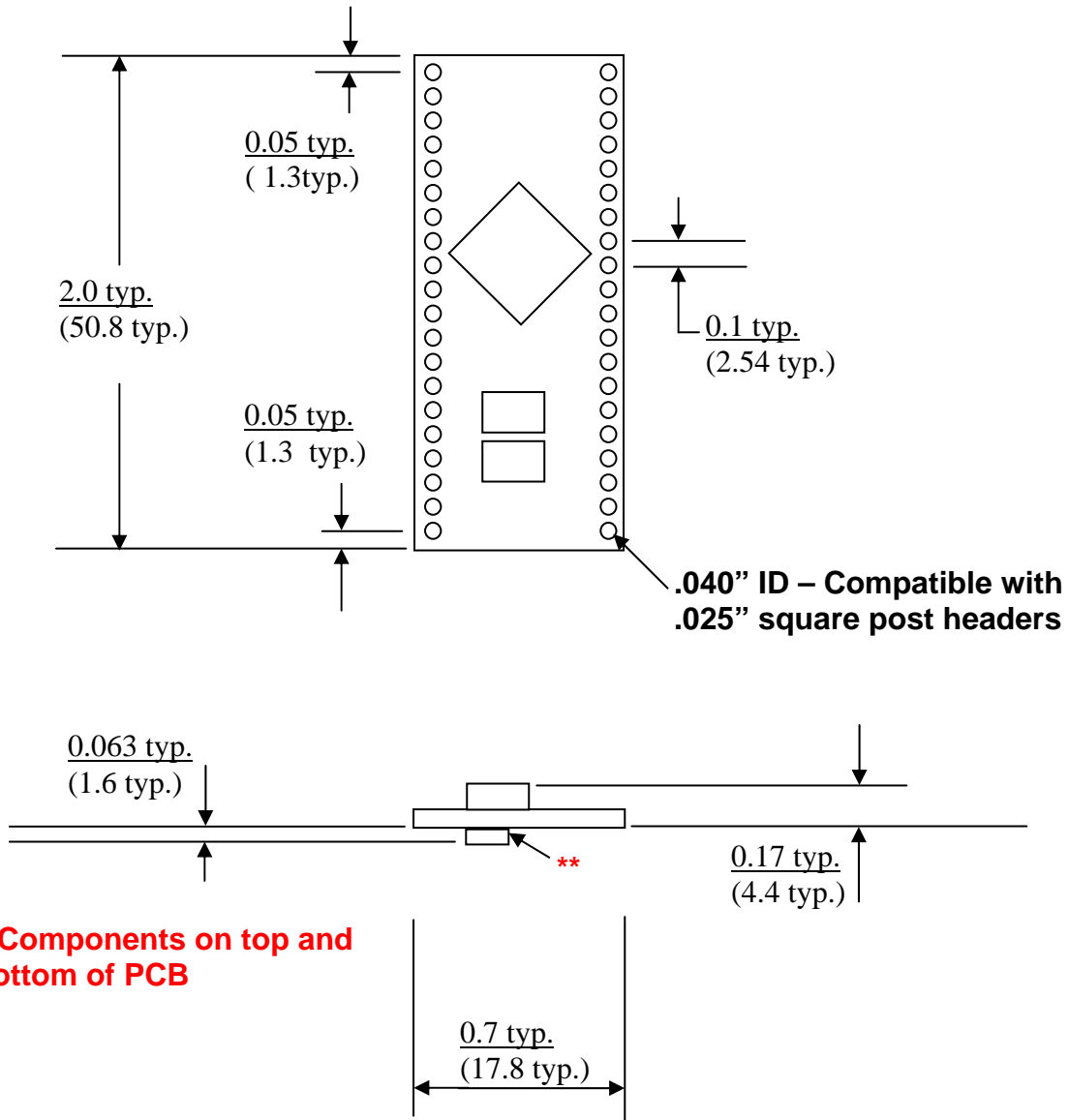

4.0 Disclaimer

© DLP Design, Inc., 2002 / 2008

Neither the whole nor any part of the information contained in, or the product described in this manual, may be adapted or reproduced in any material or electronic form without the prior written consent of the copyright holder.

This product and its documentation are supplied on an as-is basis and no warranty as to their suitability for any particular purpose is either made or implied. DLP Design, Inc. will not accept any claim for damages howsoever arising as a result of use or failure of this product. Your statutory rights are not affected. This product or any variant of it is not intended for use in any medical appliance, device or system in which the failure of the product might reasonably be expected to result in personal injury.

This document provides preliminary information that may be subject to change without notice.

5.0 Contact Information

DLP Design, Inc.

1605 Roma Ln.

Allen, TX 75013

Phone: 469-964-8027

Fax: 415-901-4859

E-Mail (Sales) : sales@dlpdesign.com

E-Mail (Support) : support@dlpdesign.com

Web Site URL : <http://www.dlpdesign.com>

DLP-2232ML MODULE

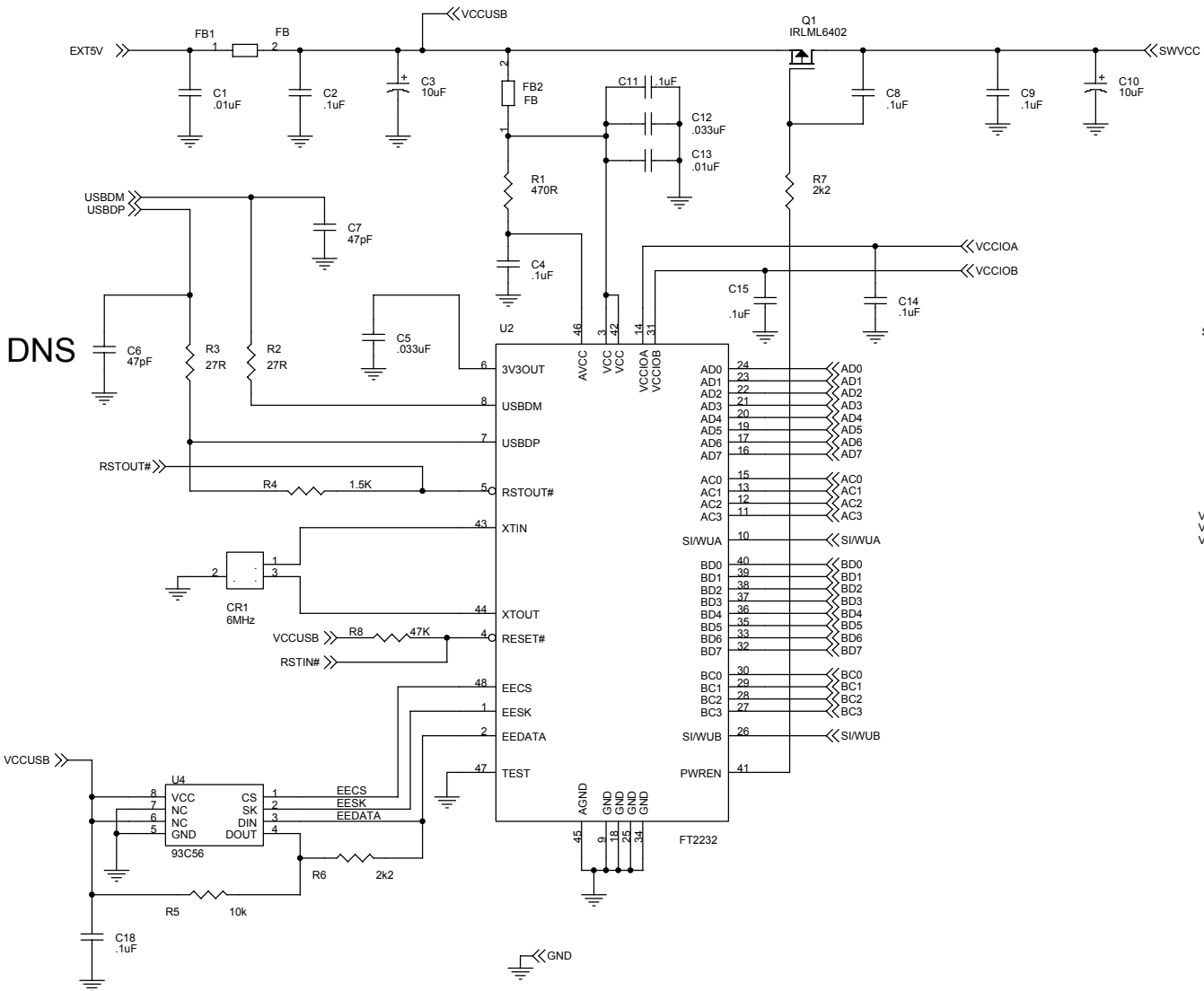

CONN PCB 20x2

SIWUB	1	40	AD0
BC3	2	39	AD1
BC2	3	38	AD2
BC1	4	37	AD3
BC0	5	36	AD4
BD7	6	35	AD5
BD6	7	34	AD6
BD5	8	33	AD7
BD4	9	32	AC0
BD3	10	31	AC1
BD2	11	30	AC2
BD1	12	29	AC3
BD0	13	28	SIWUA
GND	14	27	RSTIN#
GND	15	26	RSTOUT#
VCCSW	16	25	GND
GND	17	24	GND
VCCIOB	18	23	GND
EXT5V	19	22	USBDM
GND	20	21	USBDP
			VCCUSB

Title		<Title>
Size	Document Number	Rev
B	<Doc>	<Rev Code>
Date:	Saturday, April 17, 2004	Sheet 1 of 1