

FTDITM
Chip

**Future Technology
Devices International Ltd.**



VINCULUM
BINDING USB TECHNOLOGIES

VMusic2

Vinculum VNC1L Module



<http://www.vinculum.com>

1. Introduction and Features

1.1 Introduction

The VMusic2 module is a product which not only lets you add USB Flash disk interfacing to your product, but also allows you to play back MP3 and other popular digital music formats directly from a USB flash disk. Only four signal lines plus 5V supply and ground are required to be connected. Extensions to the Vinculum VDAP command set allow you to play a selected file, as well as control the volume, balance, etc. of the sound channel, and monitor the status of the file being played. The Vinculum VDAP firmware also allows the VNC1L's I/O interface to be selected between the serial UART or SPI using on-board jumper pins. The VMusic2 is ideal for adding MP3 playback from USB drive capability to home entertainment and in-car audio systems, as well as other appliances requiring audio playback capability from USB Flash disks. Not only is the VDrive2 ideal for evaluation and development of VNC1L designs, but also its neat enclosure and attractive quantity discount structure makes this module suitable for incorporation into finished product designs.

The Vinculum VNC1L is the first of F.T.D.I.'s Vinculum family of Embedded SoC USB host controller integrated circuit devices. Not only is it able to handle the USB Host Interface, and data transfer functions but owing to the inbuilt MCU and embedded Flash memory, Vinculum can encapsulate the USB device classes as well. When interfacing to mass storage devices such as USB Flash drives, Vinculum also transparently handles the FAT file structure communicating via UART, SPI or parallel FIFO interfaces via a simple to implement command set. Vinculum provides a new cost effective solution for providing USB Host capability into products that previously did not have the hardware resources available.

1.2 Features

- Uses F.T.D.I.'s VNC1L-1A embedded USB host controller I.C. device combined with VLSI VS1003 I.C. for music playback.
- USB 'A' type socket to connect USB Flash disk.
- Stereo 3.5mm headphone jack socket for audio playback
- Audio line-out connector for audio playback
- Only four signals to connect, excluding power and ground.
- Jumper selectable UART or SPI interfaces.
- Single 5V supply input.
- Traffic indicator LED.
- Uses extended Vinculum VDAP firmware and command set.
- Program or update firmware via USB Flash disk or via UART interface.
- VNC1L firmware programming control pins PROG# and RESET# brought out onto internal jumper interface (only accessible on internal module PCB)
- VMusic2 is a Pb-free, RoHS complaint development module.
- Schematics, and firmware files available for download from the [Vinculum website](#).

2. Pin Out

2.1 VMusic2 Pin Out

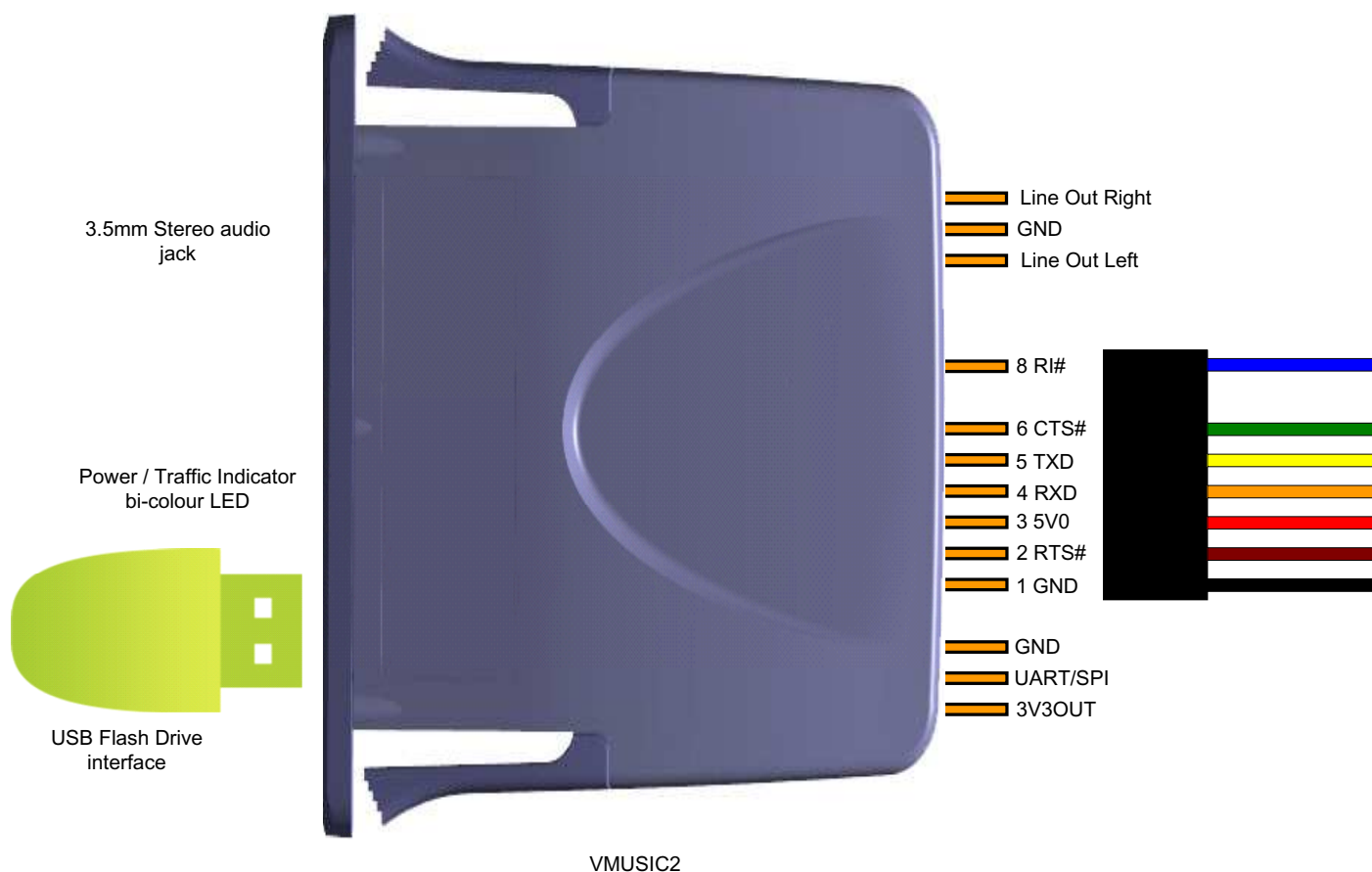

Figure 1 - VMusic2 Pin Out - UART interface.

Table 1 - Port Selection Jumper Pins

UART/SPI	I/O Mode
Pull-Up	Serial UART
Pull-Down	SPI

2.2 UART Interface Signal Descriptions

Table 2 - Data and Control Bus Signal Mode Options - UART Interface

Pin No.	Name	Type	Description
1	GND	PWR	Signal ground
2	RTS#	Output	Request To Send Control Output / Handshake signal
3	5V0	PWR	5V supply input
4	RXD	Input	Receive asynchronous data input
5	TXD	Output	Transmit asynchronous data output
6	CTS#	Input	Clear To Send Control Input / Handshake signal
7	NC	-	No Connect
8	RI#	Input	Ring Indicator Control Input. Used to resume the Vinculum from suspend.

2.3 SPI Interface Signal Descriptions and Timing Diagrams

Table 3 - Data and Control Bus Signal Mode Options - SPI Interface

Pin No.	Name	Type	Description
5	SCLK	Input	SPI Clock input, 12MHz maximum.
4	SDI	Input	SPI Serial Data Input
2	SDO	Output	SPI Serial Data Output
6	CS	Input	SPI Chip Select Input

Figure 2 - SPI Slave Data Read Cycle

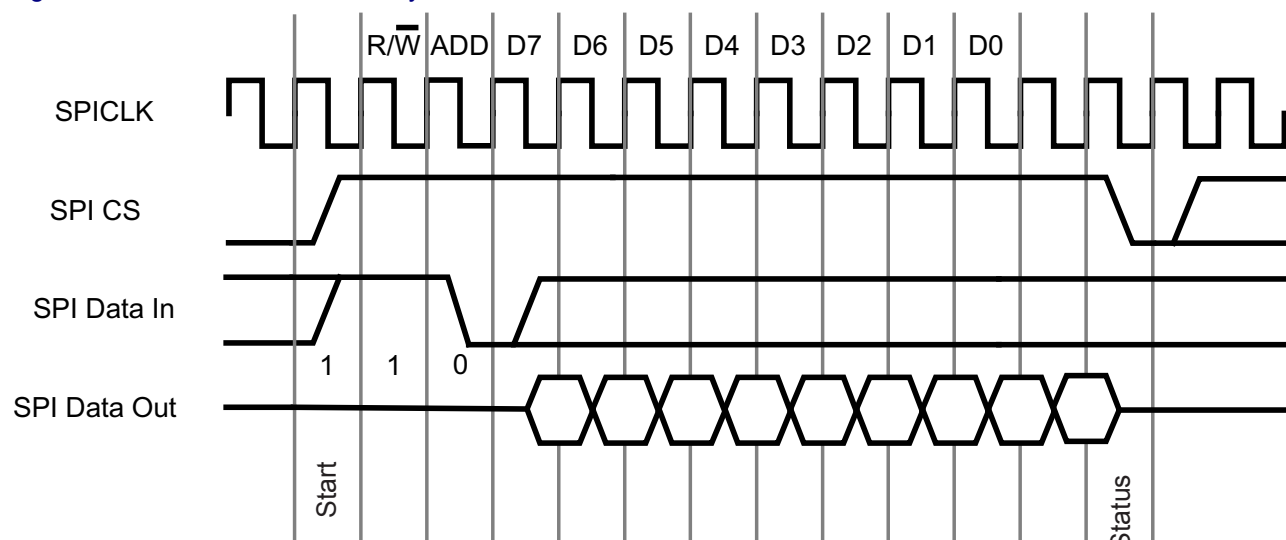

From Start - SPI CS must be held high for the entire read cycle, and must be taken low for at least one clock period after the read is completed. The first bit on SPI Data In is the R/W bit - inputting a '1' here allows data to be read from the chip. The next bit is the address bit, ADD, which is used to indicate whether the data register ('0') or the status register ('1') is read from. During the SPI read cycle a byte of data will start being output on SPI Data Out on the next clock cycle after the address bit, MSB first. After the data has been clocked out of the chip, the status of SPI Data Out should be checked to see if the data read is new data. A '0' level here on SPI Data Out means that the data read is new data. A '1' indicates that the data read is old data, and the read cycle should be repeated to get new data. Remember that CS must be held low for at least one clock period before being taken high again to continue with the next read or write cycle.

Figure 3 - SPI Slave Data Write Cycle

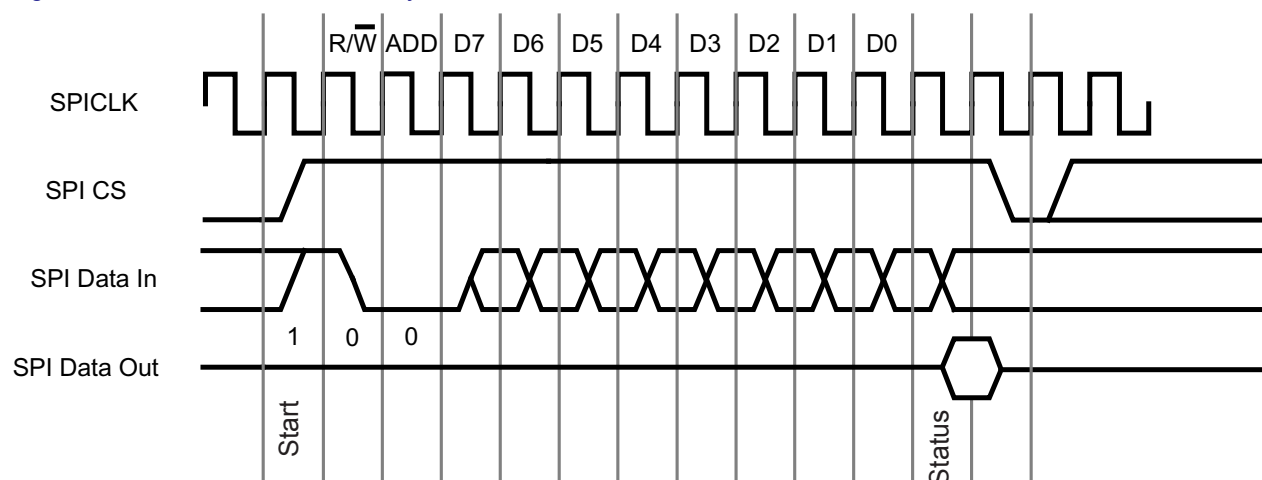

From Start - SPI CS must be held high for the entire write cycle, and must be taken low for at least one clock period after the write is completed. The first bit on SPI Data In is the R/W bit - inputting a '0' here allows data to be written to the chip. The next bit is the address bit, ADD, which is used to indicate whether the data register ('0') or the status register ('1') is written to. During the SPI write cycle a byte of data can be input to SPI Data In on the next clock cycle after the address bit, MSB first. After the data has been clocked in to the chip, the status of SPI Data Out should be

checked to see if the data read was accepted. A '0' level on SPI Data Out means that the data write was accepted. A '1' indicates that the internal buffer is full, and the write should be repeated. Remember that CS must be held low for at least one clock period before being taken high again to continue with the next read or write cycle.

Figure 4 - SPI Slave Data Timing Diagrams

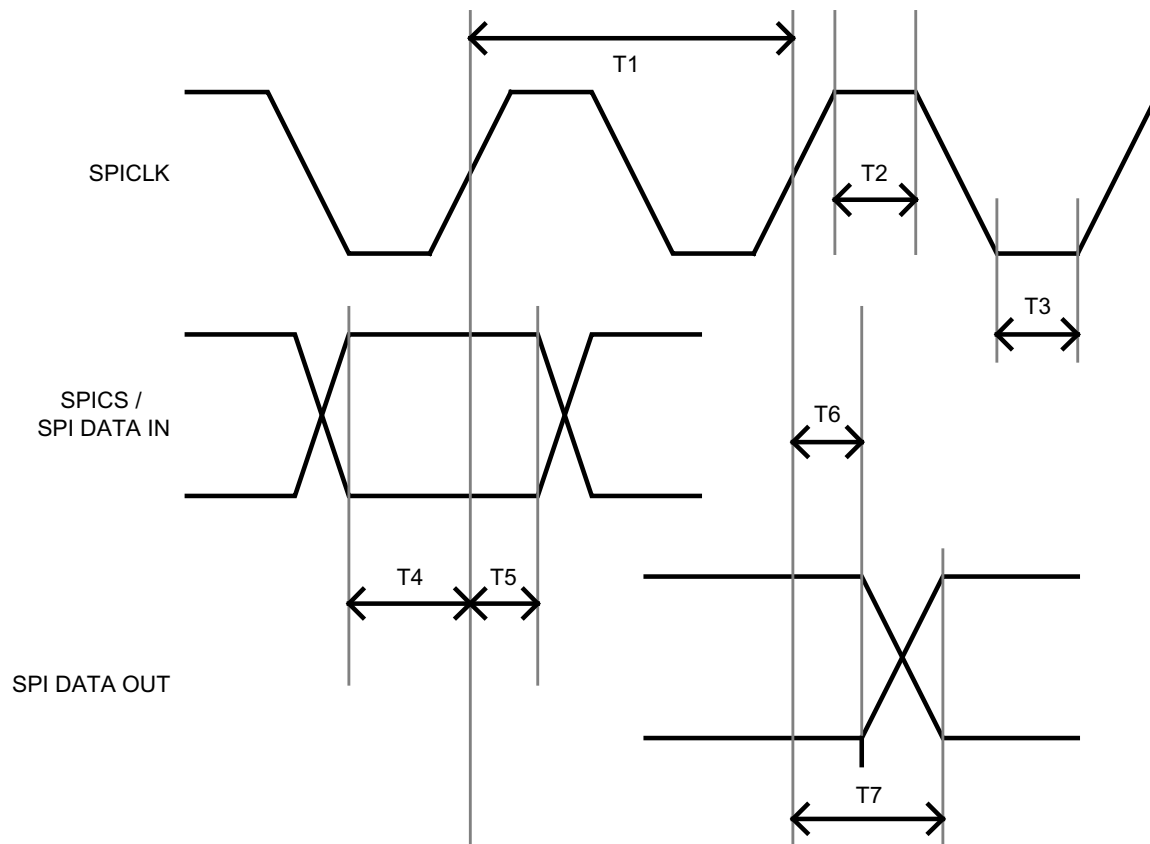

Table 4 - SPI Slave Data Timing

Time	Description	Min	Typical	Max	Unit
T1	SPICLK Period	83	-	-	ns
T2	SPICLK High	20	-	-	ns
T3	SPICLK Low	20	-	-	ns
T4	Input Setup Time	10	-	-	ns
T5	Input Hold Time	10	-	-	ns
T6	Output Hold Time	2	-	-	ns
T7	Output Valid Time	-	-	20	ns

Table 5 - Status Register (ADD = '1')

Bit	Description
0	RXF#
1	TXE#
2	-
3	-
4	RXF IRQEn
5	TXE IRQEn
6	-
7	-

3. VMUSIC2 Dimensions

Figure 5 - VDRIVE2 mechanical dimensions

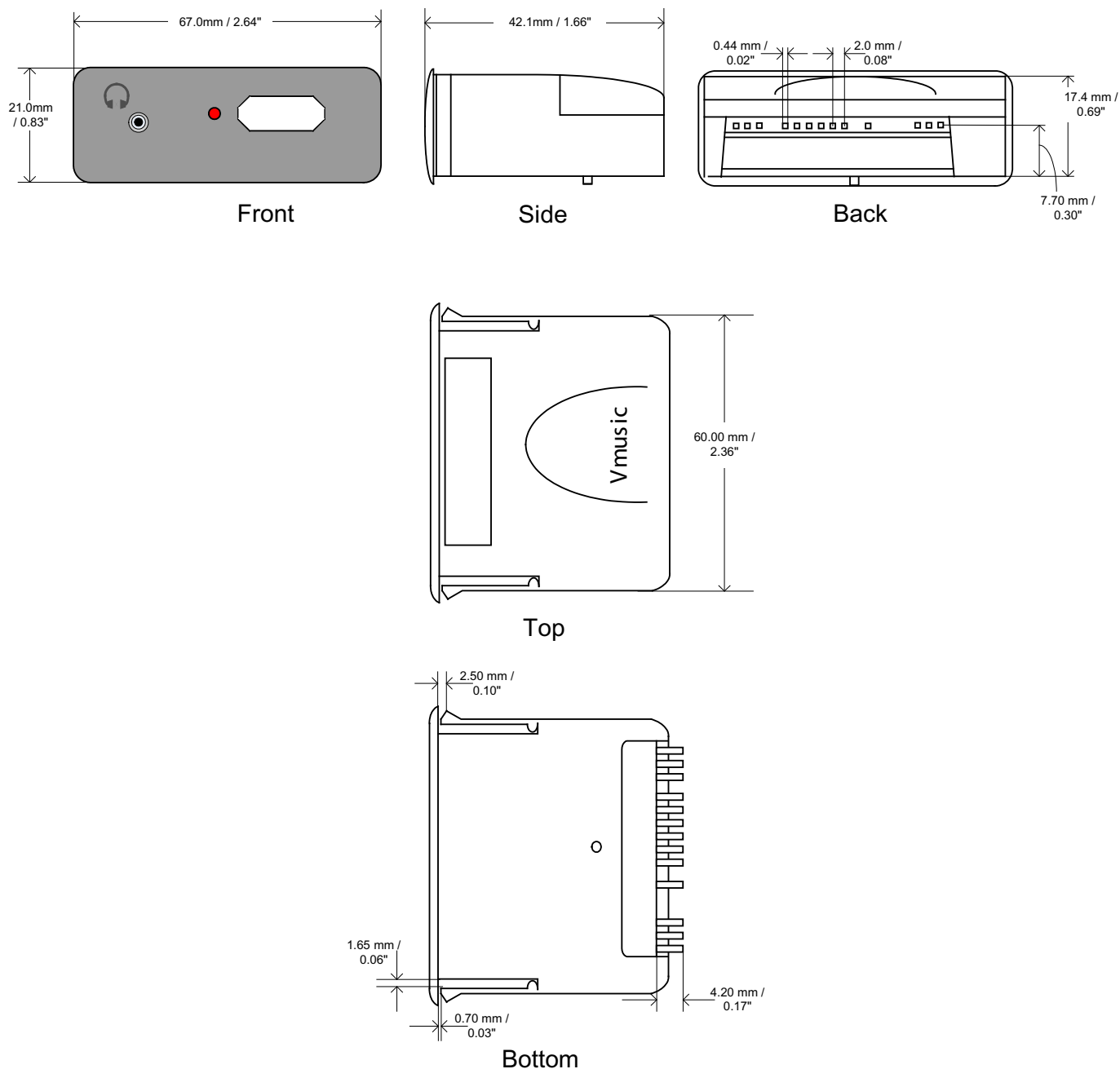

Fully detailed mechanical drawings for the VMusic2 enclosure are available on request from FTDI technical support.

4. Application Example - VMUSIC2 to PIC Micro Interface

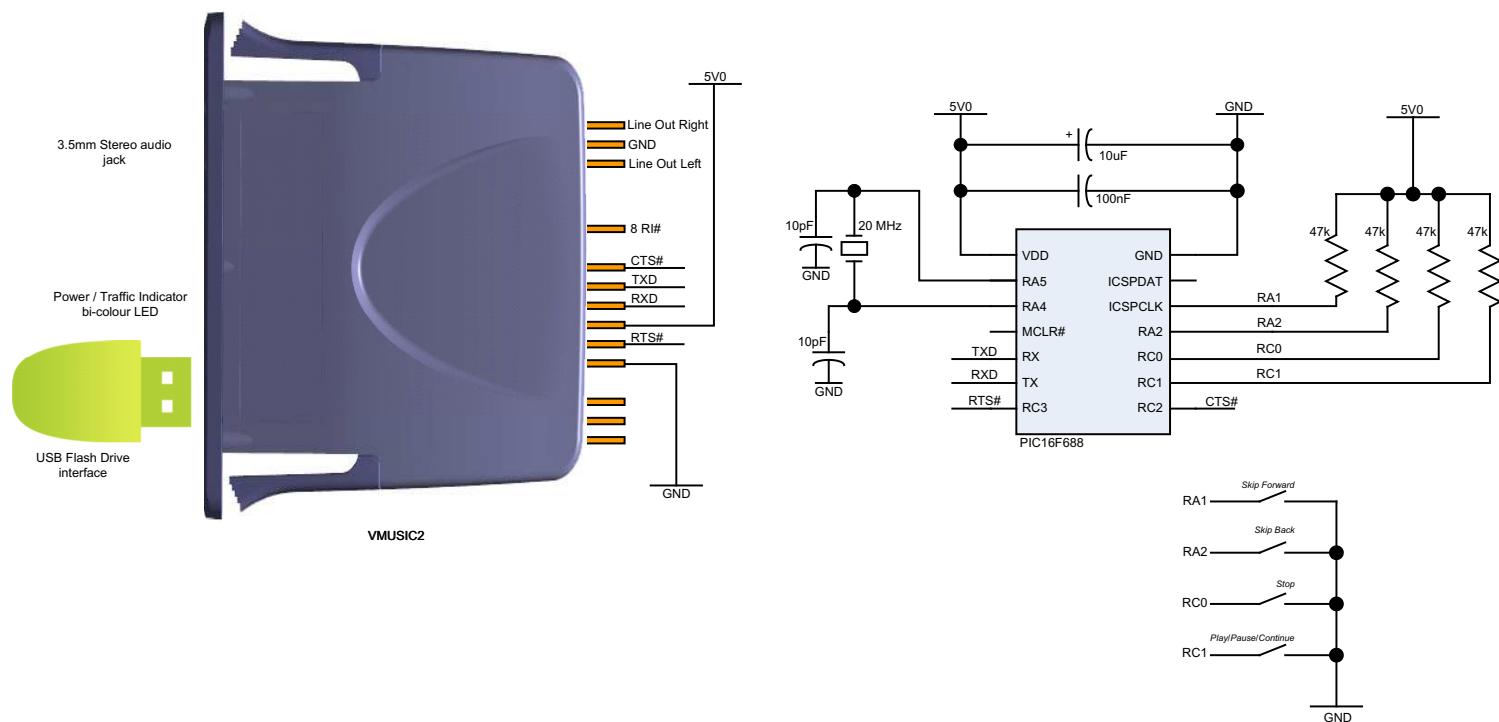

Figure 6 - MP3 playback using VMusic2 controlled by a PIC MCU

By adding a PIC microcontroller and a few other components, the VMusic2 module can be used to playback audio files stored on a USB flash disk. Fig 5 shows the schematic of this simple application. Four push buttons are connected to the inputs on the PIC. These buttons are used to control play / pause / continue / stop / skip forward / skip back / volume up and volume down. The Microchip PIC code is written using the standard VDAP music playback commands, and is available on request from FTDI.

Consult the Vinculum VDAP firmware datasheet for full details of the command set used by the VMusic2, including the audio playback commands.

Disclaimer

Copyright © Future Technology Devices International Limited, 2007.

Version 0.96 - Initial Datasheet Created February 2007

Version 0.98 - Initial Datasheet Created March 2007

Neither the whole nor any part of the information contained in, or the product described in this manual, may be adapted or reproduced in any material or electronic form without the prior written consent of the copyright holder.

This product and its documentation are supplied on an as-is basis and no warranty as to their suitability for any particular purpose is either made or implied.

Future Technology Devices International Ltd. will not accept any claim for damages howsoever arising as a result of use or failure of this product. Your statutory rights are not affected.

This product or any variant of it is not intended for use in any medical appliance, device or system in which the failure of the product might reasonably be expected to result in personal injury.

This document provides preliminary information that may be subject to change without notice.

Contact FTDI

Head Office -

Future Technology Devices International Ltd.

373 Scotland Street,
Glasgow G5 8QB,
United Kingdom

Tel. : +(44) 141 429 2777

Fax. : +(44) 141 429 2758

E-Mail (Sales) : sales1@ftdichip.com

E-Mail (Support) : support1@ftdichip.com

E-Mail (General Enquiries) : admin1@ftdichip.com

Regional Sales Offices -

Future Technology Devices International Ltd. (Taiwan)

4F, No 18-3,
Sec. 6 Mincyuan East Road,
Neihu District,
Taipei 114,
Taiwan, R.o.C.

Tel.: +886 2 8791 3570

Fax: +886 2 8791 3576

E-Mail (Sales): tw.sales1@ftdichip.com

E-Mail (Support): tw.support@ftdichip.com

E-Mail (General Enquiries): tw.admin@ftdichip.com

Website URL : <http://www.ftdichip.com>

Future Technology Devices International Ltd. (USA)

7235 NW Evergreen Parkway,
Suite 600
Hillsboro,
OR 97124-5803
USA

Tel.: +1 (503) 547-0988

Fax: +1 (503) 547-0987

E-Mail (Sales): us.sales@ftdichip.com

E-Mail (Support): us.support@ftdichip.com

E-Mail (General Enquiries): us.admin@ftdichip.com