

RoHS Q2L Series (C-Rated) SIDACTor® SLIC Device

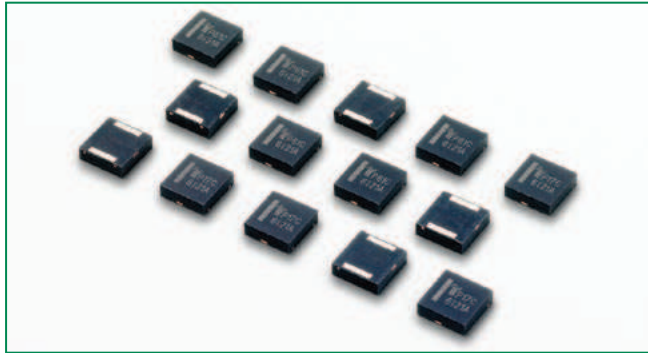

Description

The Q2L SIDACTor SLIC series provides unidirectional transient voltage protection in a low profile, Chip Scale Package (CSP). The small package QFN (Quad Flatpak No-Lead) is ideal for dense board applications that have multiple lines per card. The high density SLIC cards will benefit from this CSP technology by being able to “fit more” protection in a smaller PCB area.

Features

- RoHS compliant
- Chip Scale Package (CSP) sizing
- Wide range of I_{PP} ratings including:
500A for 2x10µs GR 1089 waveform
200A for 5x310/10x700µs ITU/YDT waveform
100A for 10x1000µs GR 1089 waveform
150A for 10x560µs TIA-968-A
- Unidirectional transient voltage protection
- Small footprint (QFN)
- Teccor brand SIDACTor technology

Agency Approvals

Agency	Agency File Number
	E133083

Protection solution to meet

- YD/T 950
- YD/T 993
- YD/T 1082
- GR 1089
- IEC 61000-4-5
- ITU K.20/21 Basic/Enhanced
- TIA-968-A

Electrical Characteristics

Part Number	Marking	V_{DRM} @ $I_{DRM}=5\mu A$	V_S @100V/µs	I_H	I_S	I_T	V_T @ $I_T=1$ amp	Capacitance @1MHz @ V bias	
		Volts	Volts	mAmps	mAmps	Amps	Volts	pF	
		Min	Max	Min			Max	Min	Max
P0641Q22CLRP	P61C	58	77	150	800	2.2	5	35	75
P0721Q22CLRP	P71C	65	88	150	800	2.2	5	25	45
P0901Q22CLRP	P91C	75	98	150	800	2.2	5	55	85
P1101Q22CLRP	P01C	95	130	150	800	2.2	5	50	75
P1301Q22CLRP	P13C	120	160	150	800	2.2	5	45	70
P1701Q22CLRP	P17C	160	200	150	800	2.2	5	45	70

- All measurements are made at an ambient temperature of 25°C.
- V_{DRM} is measured at I_{DRM} .
- $V_F = 5V$ for all ratings.
- V_F is measured at 100V/µs

- Special voltage (V_S and V_{DRM}) and holding current (I_H) requirements are available upon request.
- Parallel capacitive loads may affect electrical parameters.
- Cathode is marked by a line.

Surge Ratings

Series	I_{pp}					I_{TSM}	di/dt
	2x10 μ s	1.2x50 μ s/8x20 μ s	10x160 μ s	10x560 μ s	10x1000 μ s	AC 60Hz	
	Amps	Amps	Amps	Amps	Amps	Amps	Amps/ μ s
	Min	Min	Min	Min	Min	Min	Max
C	500	400	200	150	100	30	500

- I_{pp} applies to -40°C through +85°C temperature range.
- I_{pp} is a repetitive surge rating and is guaranteed for the life of the product.

Thermal Considerations

Package	Symbol	Parameter	Value	Unit
	T_J	Operating Junction Temperature Range	-40 to +150	°C
	T_S	Storage Temperature Range	-65 to +150	°C
	$R_{\theta JA}$	Thermal Resistance: Junction to Ambient	120	°C/W

V-I Characteristics

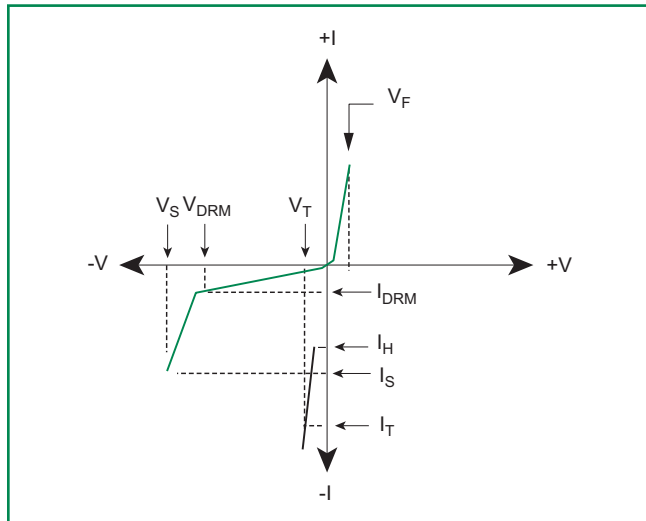

$t_r \times t_d$ Pulse Waveform

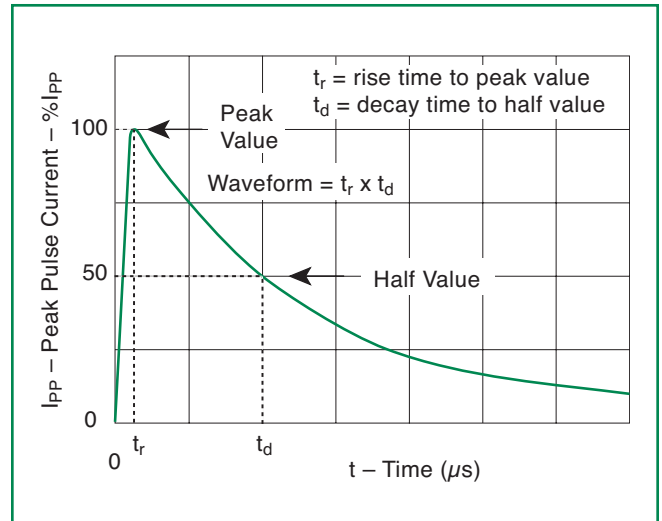

Normalized V_S Change Versus Junction Temperature

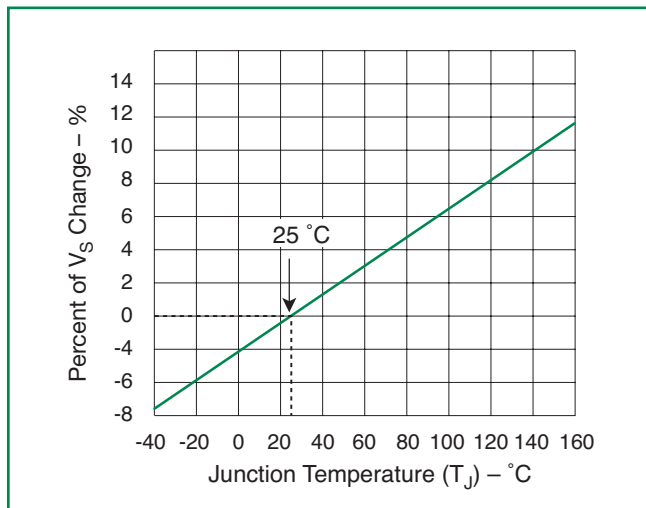

Normalized DC Holding Current Versus Case Temperature

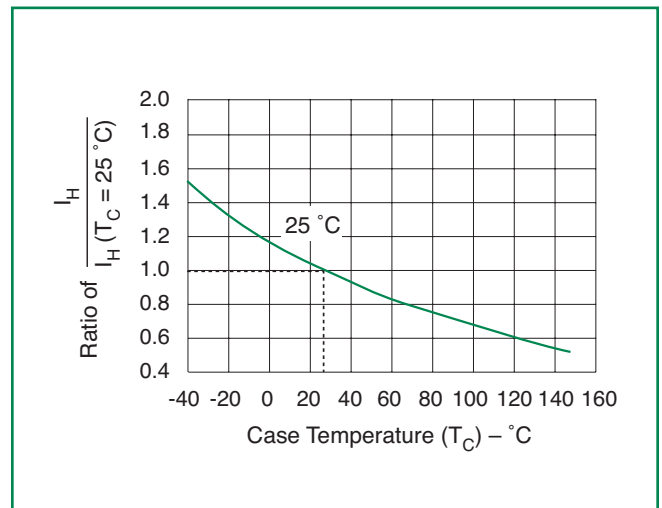

Soldering Parameters

Reflow Condition		Pb – Free assembly
Pre Heat	- Temperature Min ($T_{s(min)}$)	150°C
	- Temperature Max ($T_{s(max)}$)	190°C
	- Time (min to max) (t_s)	90 – 120 seconds
Average ramp up rate (Liquidus Temp (T_L) to peak)		5°C/second max
$T_{s(max)}$ to T_L - Ramp-up Rate		2°C/second max
Reflow	- Temperature (T_L) (Liquidus)	217°C
	- Time (min to max) (t_s)	60 – 90 seconds
Peak Temperature (T_p)		250 ^{+0/-5} °C
Time within 5°C of actual peak Temperature (t_p)		20 – 40 seconds
Ramp-down Rate		4°C/second max
Time 25°C to peak Temperature (T_p)		8 minutes Max.
Do not exceed		260°C

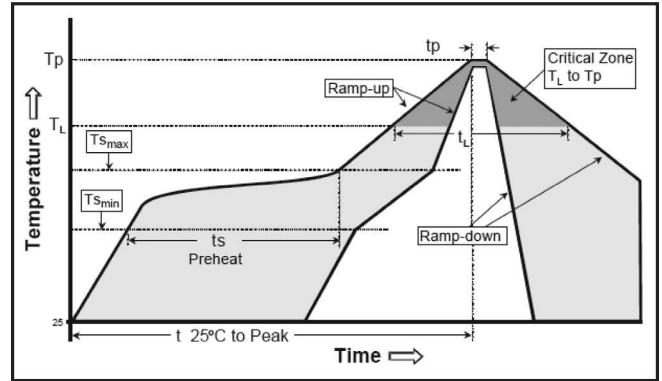

• Reference Tech Brief (EC642) for additional soldering information and placement guidelines.

Physical Specifications

Terminal Material	Matte Tin-plated Copper
Lead Solderability	ANSI/J-STD-002

Environmental Specifications

Operating/Storage Temperature	-40° C to ~ +150°C
Passive Aging	125° C, 1000 hours Meet Spec
Humidity Aging	+85°C, 85% R.H. 1000 hours Meet Spec
Thermal Shock	MIL-STD-202 Method 107G +85°C/-40°C 100 times Meet spec
Solvent Resistance	MIL-STD-202, Method 215 No Change
Vibration	MIL-STD-883C, Method 2007.1, Condition A No Change

Dimensions

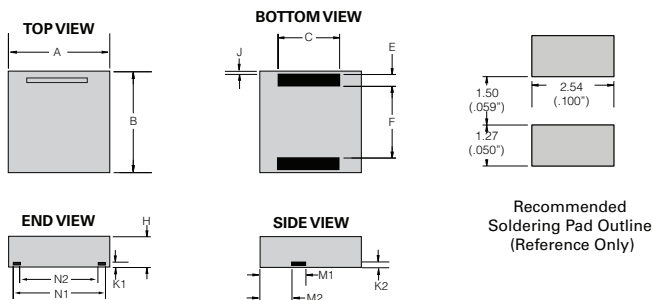

Dimensions	Inches			Millimeters		
	Min	Typ	Max	Min	Typ	Max
A	0.126	0.130	0.134	3.200	3.300	3.400
B	0.126	0.130	0.134	3.200	3.300	3.400
C	0.075	0.079	0.083	1.900	2.000	2.100
E	0.011	0.015	0.019	0.285	0.385	0.485
F	0.088	0.092	0.096	2.230	2.330	2.430
H	0.035	0.039	0.043	0.900	1.000	1.100
J	0.000	0.004	0.008	0.000	0.100	0.200
K1	0.004	0.008	0.012	0.100	0.200	0.300
K2	0.004	0.008	0.012	0.100	0.200	0.300
M1	0.063	0.067	0.071	1.610	1.710	1.810
M2	0.045	0.049	0.053	1.153	1.253	1.353
N1	0.095	0.099	0.103	2.420	2.520	2.620
N2	0.082	0.086	0.090	2.080	2.180	2.280

Part Marking System

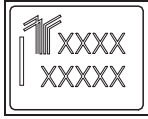

First Line: Product Name
(See marking column in table on Page 1)

Second Line: Lot number

Part Numbering System

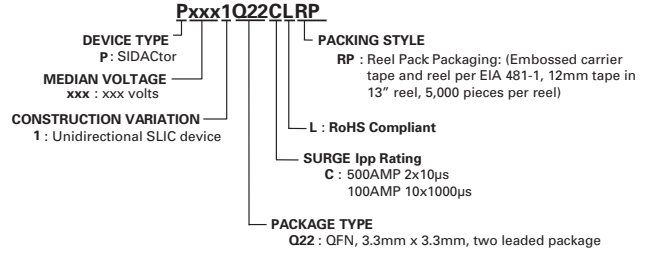

Packaging

Package Type	Description	Packing Quantity	Added Suffix	Industry Standard
QFN	Embossed Carrier Reel Pack	5000	RP	EIA-481-1

Tape and Reel Specification

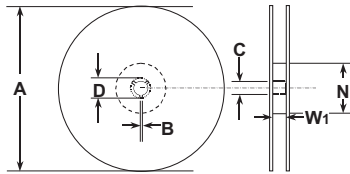

Reel Dimension

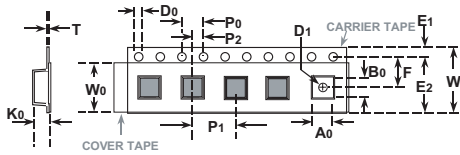

Tape Dimension Items

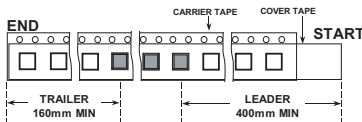

Tape Leader and Trailer Dimensions

Symbols	Description	Inches		Millimeters	
		Minimum	Maximum	Minimum	Maximum
A	Reel Diameter	N/A	12.992	N/A	330.0
B	Drive Spoke Width	0.059	N/A	1.50	N/A
C	Arbor Hole Diameter	0.504	0.531	12.80	13.50
D	Drive Spoke Diameter	0.795	N/A	20.20	N/A
N	Hub Diameter	1.969	N/A	50.00	N/A
W1	Reel Inner Width at Hub	0.488	0.567	12.40	14.40
A0	Pocket Width at bottom	0.138	0.146	3.50	3.70
B0	Pocket Length at bottom	0.138	0.146	3.50	3.70
D0	Feed Hole Diameter	0.059	0.063	1.50	1.60
D1	Pocket Hole Diameter	0.059	N/A	1.50	N/A
E1	Feed hole position 1	0.065	0.073	1.65	1.85
E2	Feed hole position 2	0.400	0.408	10.15	10.35
F	Feed hole center-Pocket hole	0.215	0.219	5.45	5.55
K0	Pocket Depth	0.039	0.051	1.00	1.30
P0	Feed Hole Pitch	0.153	0.161	3.90	4.10
P1	Component Spacing	0.311	0.319	7.90	8.10
P2	Feed hole center-Pocket hole	0.077	0.081	1.95	2.05
T	Carrier Tape Thickness	0.010	0.014	0.25	0.35
W	Embossed Carrier Tape Width	0.453	0.484	11.50	12.30
W0	Cover Tape Width	0.358	0.366	9.10	9.30