

Nominal breakdown voltage V_N	800	V
Initial values ²⁾		
Static breakdown voltage V_S ¹⁾		
First ignition value $V_{S, FTE}$ after 24 hours in darkness	≤ 950	V
Following ignition values $V_{S, FIV}$	704 ... 896	V
Electrical life time ³⁾		
Breakdown voltage V_B up to 100 000 Ignitions		
First ignition value $V_{B, FTE}$ after 24 hours in darkness	≤ 1000	V
Ignition time t_i at V_0 during life	≤ 60	ms
Following ignition values $V_{B, FIV}$ at 50 000 Ignitions	704 ... 920	V
Following ignition values $V_{B, FIV}$	680 ... 920	V
Switching operations in total	100 000	Ignitions
at $-40; +150$ °C, each	10 000	Ignitions
at $+25; +125$ °C, each	40 000	Ignitions
Test circuit parameters		
Open circuit voltage V_0	1000	V
Loading resistance R	56	k Ω
Discharge capacitance C	114	nF
Inductance L	0.13	μ H
Discharge peak current I_P	~ 660	A
General technical data		
Insulation resistance at 100 V	> 100	M Ω
Early ignition values between 530 ... 680 V	≤ 1	%
Breakdown time	≤ 50	ns
Maximum loading current	50	mA
Weight	~ 2	g
Marking, blue	EPCOS 800 WWY O	
	800	- Nominal voltage
	WW	- Calendar week of production
	Y	- Year of production
	O	- Non radioactive

^{a)} xxxx = T502 (taped and reeled with 500 pcs.)
= T103 (taped and reeled with 1000 pcs.)

¹⁾ At delivery AQL 0,65 level II, DIN ISO 2859

²⁾ Page 2, Fig. 1 and 2

³⁾ Page 2, Fig. 3 and 4

Fig. 1: QC- test circuit (100% outgoing inspection)

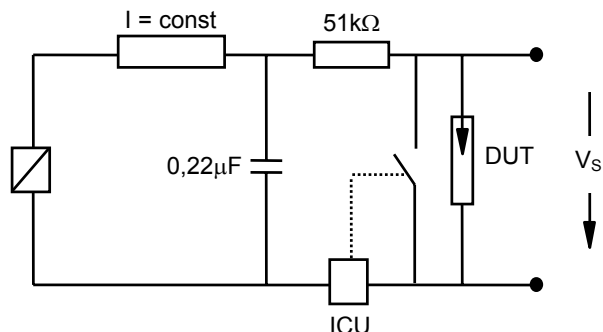

DUT device under test
 ICU ignition control unit (sensitivity 10 .. 30 μA)
 Discharge current 10 – 20 mA

Fig. 2: Explanation of measurands

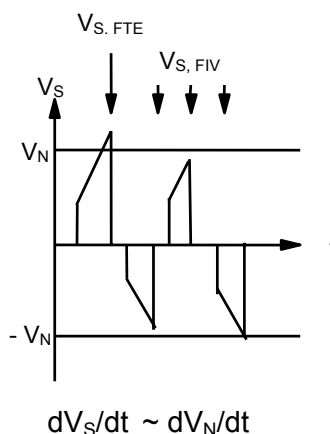

Fig. 3: QC- test circuit (sampling inspection at 25 °C)

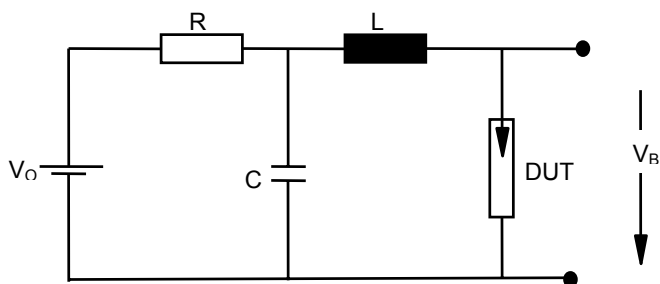
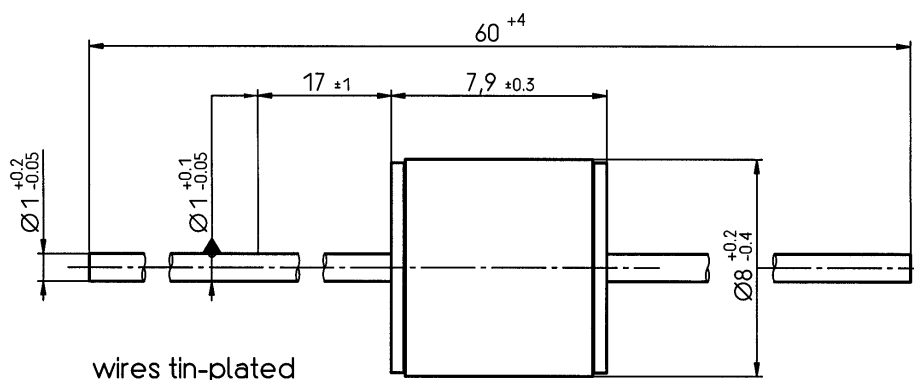
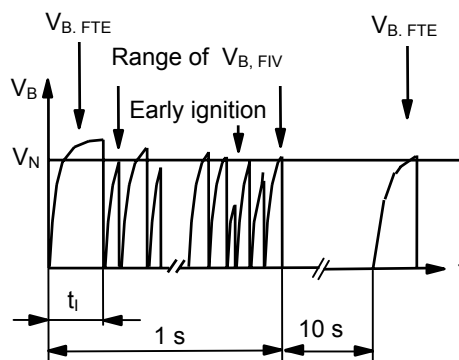

Fig. 4: Explanation of measurands



Not to scale
 Dimensions in mm
 Non controlled document

© EPCOS AG 2002. Reproduction, publication and dissemination of this data sheet, enclosures hereto and the information contained therein without EPCOS' prior express consent is prohibited.

Purchase orders are subject to the General Conditions for the Supply of Products and Services of the Electrical and Electronics Industry recommended by the ZVEI (German Electrical and Electronic Manufacturers' Association), unless otherwise agreed.