



Aluminum electrolytic capacitors

Snap-in capacitors

Series/Type: B41231

Date: December 2010

General-purpose grade capacitors

Applications

- Switch-mode power supplies in industrial and entertainment electronics

Features

- High ripple current capability
- RoHS-compatible
- Useful life of 2000 h at 85 °C

Construction

- Aluminum case, fully insulated
- Snap-in solder pins to hold component in place on PC-board
- Minus pole marking on the insulating sleeve
- Case with safety vent

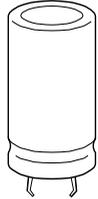

Specifications and characteristics in brief

Rated voltage V_R	10 ... 100 V DC								
Surge voltage V_S	1.15 V_R (at room temperature)								
Rated capacitance C_R	1200 ... 68000 nF								
Capacitance tolerance	±20% M								
Dissipation factor (max.) (20 °C, 120 Hz)	V_R (V DC)	10	16	25	35	50	63	80	100
	tan d	0.50	0.50	0.40	0.40	0.30	0.25	0.20	0.15
Leakage current I_{leak} (20 °C, after 5 minutes)	$I_{leak} \leq 0.02 \mu A \cdot \left(\frac{C_R}{\mu F} \cdot \frac{V_R}{V} \right)$								
Useful life 85 °C; V_R ; $I_{AC,R}$	> 2000 h	Requirements:							
		DC/C	£ 20% of initial value						
		tan d	£ 2 times initial specified limit						
		I_{leak}	£ initial specified limit						
Vibration resistance test	To IEC 60068-2-6, test Fc: Frequency range 10 Hz ... 55 Hz, displacement amplitude 0.75 mm, acceleration max. 10 g, duration 3 ´ 2 h. Capacitor rigidly clamped by the aluminum case								
Shelf life	After storage for 1000 h at 85 °C, the capacitors shall meet the requirement of load life test after reforming process. After test: V_R to be applied for 30 minutes, 24 to 48 hours before measurement.								
Operating temperature range	40 °C ... +85 °C								
Characteristics at low temperature	Max. impedance ratio at 120 Hz	V_R	10 V	16 ... 100 V					
		$Z_{-25^\circ C} / Z_{20^\circ C}$	5	4					
		$Z_{-40^\circ C} / Z_{20^\circ C}$	18	15					
IEC climatic category	To IEC 60068-1: 25/085/56 (25 °C/+85 °C/56 days damp heat test)								
Sectional specification	IEC 60384-4								



B41231

Standard series 85 °C

Dimensional drawing

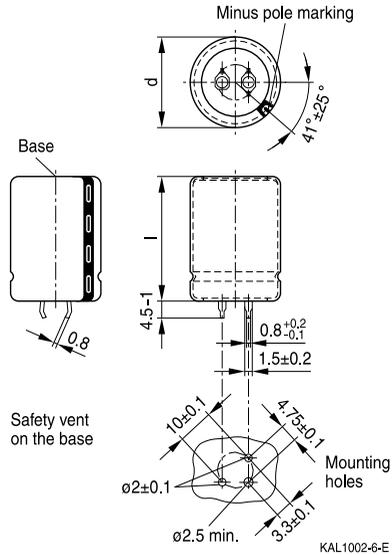
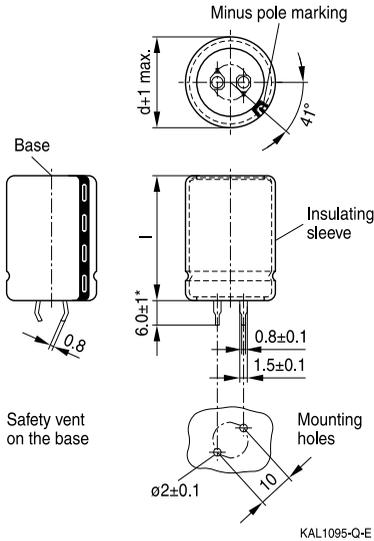

Snap-in terminals, length (6.0 ±1) mm.
Also available in a shorter version with a length of (4.5 ±1) mm.

Snap-in capacitors are also available with 3 terminals (length (4.5 ±1) mm).

Dimensions (mm)		Approx. weight (g)	Packing units (pcs.)
d +1	l ±2		
22	20	10.2	200
22	25	13.0	200
22	30	15.0	100
22	35	20.5	100
22	40	23.0	100
22	45	25.0	100
22	50	29.5	100
25.4	20	12.5	100
25.4	25	13.5	100
25.4	30	19.5	50
25.4	35	25.0	50
25.4	40	28.0	50
25.4	45	31.0	50
25.4	50	39.0	50

Dimensions (mm)		Approx. weight (g)	Packing units (pcs.)
d +1	l ±2		
30	25	24.5	100
30	30	25.5	100
30	35	32.5	50
30	40	39.0	50
30	45	43.5	50
30	50	55.5	50
30	55	57.5	50
35	25	35.0	80
35	30	43.0	80
35	35	50.5	50
35	40	52.0	50
35	45	65.0	50
35	50	70.5	50



Overview of available types

V_R (V DC)	10	16	25	35	50	63	80	100
	Case dimensions d ´ l (mm)							
C_R (nF)								
1200							22 ´ 25 25.4 ´ 25	22 ´ 30 25.4 ´ 25
1500							22 ´ 30 25.4 ´ 30	22 ´ 35 25.4 ´ 30 30 ´ 25
1800						22 ´ 25 25.4 ´ 25	22 ´ 30 25.4 ´ 25	22 ´ 40 25.4 ´ 35 30 ´ 30
2200						22 ´ 30 25.4 ´ 25 30 ´ 25	22 ´ 35 25.4 ´ 30 30 ´ 25	22 ´ 45 25.4 ´ 40 30 ´ 30
2700						22 ´ 35 25.4 ´ 30 30 ´ 30	22 ´ 40 25.4 ´ 35 30 ´ 30	25.4 ´ 45 30 ´ 35 35 ´ 30
3300					22 ´ 30 25.4 ´ 25	22 ´ 35 25.4 ´ 30 30 ´ 25	22 ´ 45 25.4 ´ 40 30 ´ 30	25.4 ´ 50 30 ´ 40 35 ´ 35
3900						22 ´ 40 25.4 ´ 35 30 ´ 30	22 ´ 50 25.4 ´ 45 30 ´ 35	30 ´ 45 35 ´ 35
4700				22 ´ 30 25.4 ´ 25 30 ´ 25 35 ´ 25	22 ´ 40 25.4 ´ 35 30 ´ 25 35 ´ 25	22 ´ 50 25.4 ´ 40 30 ´ 35 35 ´ 30	25.4 ´ 50 30 ´ 40 35 ´ 30	30 ´ 50 35 ´ 40
5600			22 ´ 25 25.4 ´ 30	22 ´ 35 25.4 ´ 30	22 ´ 45 25.4 ´ 40 30 ´ 30 35 ´ 25	25.4 ´ 45 30 ´ 35 35 ´ 30	30 ´ 45 35 ´ 35	35 ´ 45
6800			22 ´ 30 25.4 ´ 25	22 ´ 40 25.4 ´ 30 30 ´ 25	22 ´ 50 25.4 ´ 45 30 ´ 35 35 ´ 30	25.4 ´ 50 30 ´ 40 35 ´ 30	35 ´ 40	
8200			22 ´ 35 25.4 ´ 30	22 ´ 45 25.4 ´ 35 30 ´ 30	25.4 ´ 50 30 ´ 40 35 ´ 30	30 ´ 45 35 ´ 35	35 ´ 45	



B41231

Standard series 85 °C

V _R (V DC)	10	16	25	35	50	63	80	100
	Case dimensions d × l (mm)							
C _R (nF)								
10000		22 × 25	22 × 40 25.4 × 30	22 × 50 25.4 × 40 30 × 30	30 × 45 35 × 35	30 × 50 35 × 40		
12000	22 × 25	22 × 30 25.4 × 25	22 × 45 25.4 × 35 30 × 25	25.4 × 45 30 × 35 35 × 30	30 × 50 35 × 40	35 × 45		
15000	22 × 30 25.4 × 25	22 × 35 25.4 × 30 30 × 25	22 × 50 25.4 × 40 30 × 30	30 × 40 35 × 35	35 × 45			
18000	22 × 35 25.4 × 25	22 × 40 25.4 × 35 30 × 30	25.4 × 45 30 × 35	30 × 45 35 × 40	35 × 50			
22000	22 × 40 25.4 × 30 30 × 25	22 × 50 25.4 × 40 30 × 30	30 × 35 35 × 30	35 × 45				
27000	22 × 45 25.4 × 35 30 × 30	25.4 × 45 30 × 35 35 × 25	30 × 45 35 × 35					
33000	22 × 50 25.4 × 40 30 × 30 35 × 25	30 × 40 35 × 30	30 × 50 35 × 40					
39000	25.4 × 45 30 × 35 35 × 30	30 × 45 35 × 35	35 × 45					
47000	25.4 × 50 30 × 40 35 × 30	30 × 50 35 × 40						
56000	30 × 45 35 × 35	35 × 45						
68000	35 × 40	35 × 50						

Technical data and ordering codes

C_R 120 Hz 20 °C nF	Case dimensions d ´ l mm	$\tan \delta_{\max}$ 120 Hz 20 °C	$I_{AC,\max}$ 120 Hz 60 °C A	$I_{AC,R}$ 120 Hz 85 °C A	Ordering code (composition see below)
$V_R = 10 \text{ V DC}$					
12000	22 ´ 25	0.50	6.55	3.31	B41231A3129M0*#
15000	22 ´ 30	0.50	7.56	3.82	B41231A3159M0*#
15000	25.4 ´ 25	0.50	6.71	3.39	B41231B3159M0*#
18000	22 ´ 35	0.50	8.47	4.28	B41231A3189M0*#
18000	25.4 ´ 25	0.50	8.26	4.17	B41231B3189M0*#
22000	22 ´ 40	0.50	9.48	4.79	B41231A3229M0*#
22000	25.4 ´ 30	0.50	9.33	4.71	B41231B3229M0*#
22000	30 ´ 25	0.50	9.56	4.83	B41231C3229M0*#
27000	22 ´ 45	0.50	10.49	5.30	B41231A3279M0*#
27000	25.4 ´ 35	0.50	10.41	5.26	B41231B3279M0*#
27000	30 ´ 30	0.50	10.71	5.41	B41231C3279M0*#
33000	22 ´ 50	0.50	11.52	5.82	B41231A3339M0*#
33000	25.4 ´ 40	0.50	11.50	5.81	B41231B3339M0*#
33000	30 ´ 30	0.50	11.27	5.69	B41231C3339M0*#
33000	35 ´ 25	0.50	11.50	5.81	B41231D3339M0*#
39000	25.4 ´ 45	0.50	12.49	6.31	B41231A3399M0*#
39000	30 ´ 35	0.50	12.32	6.22	B41231B3399M0*#
39000	35 ´ 30	0.50	12.63	6.38	B41231C3399M0*#
47000	25.4 ´ 50	0.50	13.52	6.83	B41231A3479M0*#
47000	30 ´ 40	0.50	13.42	6.78	B41231B3479M0*#
47000	35 ´ 30	0.50	13.11	6.62	B41231C3479M0*#
56000	30 ´ 45	0.50	14.47	7.31	B41231A3569M0*#
56000	35 ´ 35	0.50	14.22	7.18	B41231B3569M0*#
68000	35 ´ 40	0.50	15.36	7.76	B41231A3689M0*#
$V_R = 16 \text{ V DC}$					
10000	22 ´ 25	0.50	6.57	3.32	B41231A4109M0*#
12000	22 ´ 30	0.50	7.03	3.55	B41231A4129M0*#
12000	25.4 ´ 25	0.50	7.70	3.89	B41231B4129M0*#
15000	22 ´ 35	0.50	8.49	4.29	B41231A4159M0*#
15000	25.4 ´ 30	0.50	8.81	4.45	B41231B4159M0*#
15000	30 ´ 25	0.50	9.03	4.56	B41231C4159M0*#

Composition of ordering code
*** = Insulation feature**

0 = PVC insulation

6 = PET insulation

= Terminal style

0 = snap-in standard terminals (6.0 ±1 mm)

2 = snap-in 3 terminals (4.5 ±1 mm)

7 = snap-in short terminals (4.5 ±1 mm)



B41231

Standard series 85 °C

Technical data and ordering codes

C_R	Case dimensions	$\tan \delta_{max}$	$I_{AC,max}$	$I_{AC,R}$	Ordering code
120 Hz	d ´ l	120 Hz	120 Hz	120 Hz	(composition see below)
20 °C	mm	20 °C	60 °C	85 °C	
nF			A	A	

$V_R = 16 \text{ V DC}$

18000	22 ´ 40	0.50	9.44	4.77	B41231A4189M0*#
18000	25.4 ´ 35	0.50	9.82	4.96	B41231B4189M0*#
18000	30 ´ 30	0.50	10.10	5.10	B41231C4189M0*#
22000	22 ´ 50	0.50	10.91	5.51	B41231A4229M0*#
22000	25.4 ´ 40	0.50	10.91	5.51	B41231B4229M0*#
22000	30 ´ 30	0.50	10.67	5.39	B41231C4229M0*#
27000	25.4 ´ 45	0.50	12.00	6.06	B41231A4279M0*#
27000	30 ´ 35	0.50	11.84	5.98	B41231B4279M0*#
27000	35 ´ 25	0.50	11.48	5.80	B41231C4279M0*#
33000	30 ´ 40	0.50	12.99	6.56	B41231A4339M0*#
33000	35 ´ 30	0.50	12.69	6.41	B41231B4339M0*#
39000	30 ´ 45	0.50	14.02	7.08	B41231A4399M0*#
39000	35 ´ 35	0.50	13.78	6.96	B41231B4399M0*#
47000	30 ´ 50	0.50	15.09	7.62	B41231A4479M0*#
47000	35 ´ 40	0.50	14.93	7.54	B41231B4479M0*#
56000	35 ´ 45	0.50	16.00	8.08	B41231A4569M0*#
68000	35 ´ 50	0.50	16.89	8.53	B41231A4689M0*#

$V_R = 25 \text{ V DC}$

5600	22 ´ 25	0.40	5.25	2.65	B41231A5568M0*#
6800	22 ´ 30	0.40	6.06	3.06	B41231A5688M0*#
6800	25.4 ´ 25	0.40	6.24	3.15	B41231B5688M0*#
8200	22 ´ 35	0.40	6.83	3.45	B41231A5828M0*#
8200	25.4 ´ 30	0.40	7.07	3.57	B41231B5828M0*#
10000	22 ´ 40	0.40	7.82	3.95	B41231A5109M0*#
10000	25.4 ´ 30	0.40	7.70	3.89	B41231B5109M0*#
12000	22 ´ 45	0.40	8.73	4.41	B41231A5129M0*#
12000	25.4 ´ 35	0.40	8.65	4.37	B41231B5129M0*#
12000	30 ´ 25	0.40	7.90	3.99	B41231C5129M0*#
15000	22 ´ 50	0.40	9.78	4.94	B41231A5159M0*#
15000	25.4 ´ 40	0.40	9.78	4.94	B41231B5159M0*#
15000	30 ´ 30	0.40	8.91	4.50	B41231C5159M0*#

Composition of ordering code

* = Insulation feature
 0 = PVC insulation
 6 = PET insulation

= Terminal style
 0 = snap-in standard terminals (6.0 ±1 mm)
 2 = snap-in 3 terminals (4.5 ±1 mm)
 7 = snap-in short terminals (4.5 ±1 mm)



Technical data and ordering codes

C_R 120 Hz 20 °C nF	Case dimensions d' l mm	$\tan \delta_{\max}$ 120 Hz 20 °C	$I_{AC,\max}$ 120 Hz 60 °C A	$I_{AC,R}$ 120 Hz 85 °C A	Ordering code (composition see below)
$V_R = 25 \text{ V DC}$					
18000	25.4 ´ 45	0.40	10.79	5.45	B41231A5189M0*#
18000	30 ´ 35	0.40	10.10	5.10	B41231B5189M0*#
22000	30 ´ 35	0.40	10.65	5.38	B41231A5229M0*#
22000	35 ´ 30	0.40	10.91	5.51	B41231B5229M0*#
27000	30 ´ 45	0.40	12.32	6.22	B41231A5279M0*#
27000	35 ´ 35	0.40	12.12	6.12	B41231B5279M0*#
33000	30 ´ 50	0.40	13.50	6.82	B41231A5339M0*#
33000	35 ´ 40	0.40	13.35	6.74	B41231B5339M0*#
39000	35 ´ 45	0.40	14.55	7.35	B41231A5399M0*#
$V_R = 35 \text{ V DC}$					
4700	22 ´ 30	0.40	6.06	3.06	B41231A7478M0*#
4700	25.4 ´ 25	0.40	5.90	2.98	B41231B7478M0*#
5600	22 ´ 35	0.40	6.49	3.28	B41231A7568M0*#
5600	25.4 ´ 30	0.40	6.71	3.39	B41231B7568M0*#
6800	22 ´ 40	0.40	7.39	3.73	B41231A7688M0*#
6800	25.4 ´ 30	0.40	7.27	3.67	B41231B7688M0*#
6800	30 ´ 25	0.40	7.44	3.76	B41231C7688M0*#
8200	22 ´ 45	0.40	8.18	4.13	B41231A7828M0*#
8200	25.4 ´ 35	0.40	8.12	4.10	B41231B7828M0*#
8200	30 ´ 30	0.40	8.36	4.22	B41231C7828M0*#
10000	22 ´ 50	0.40	9.27	4.68	B41231A7109M0*#
10000	25.4 ´ 40	0.40	9.27	4.68	B41231B7109M0*#
10000	30 ´ 30	0.40	9.07	4.58	B41231C7109M0*#
12000	25.4 ´ 45	0.40	10.26	5.18	B41231A7129M0*#
12000	30 ´ 35	0.40	10.12	5.11	B41231C7129M0*#
12000	35 ´ 30	0.40	10.38	5.24	B41231D7129M0*#
15000	30 ´ 40	0.40	11.33	5.72	B41231A7159M0*#
15000	35 ´ 35	0.40	11.64	5.88	B41231B7159M0*#
18000	30 ´ 45	0.40	12.43	6.28	B41231A7189M0*#
18000	35 ´ 40	0.40	12.79	6.46	B41231B7189M0*#
22000	35 ´ 45	0.40	14.00	7.07	B41231A7229M0*#

Composition of ordering code

* = Insulation feature

0 = PVC insulation

6 = PET insulation

= Terminal style

0 = snap-in standard terminals (6.0 ± 1 mm)

2 = snap-in 3 terminals (4.5 ± 1 mm)

7 = snap-in short terminals (4.5 ± 1 mm)

B41231
Standard series 85 °C
Technical data and ordering codes

C_R 120 Hz 20 °C nF	Case dimensions d ´ l mm	$\tan \delta_{max}$ 120 Hz 20 °C	$I_{AC,max}$ 120 Hz 60 °C A	$I_{AC,R}$ 120 Hz 85 °C A	Ordering code (composition see below)
$V_R = 50 \text{ V DC}$					
3300	22 ´ 30	0.30	5.88	2.97	B41231A6338M0*#
3300	25.4 ´ 25	0.30	7.58	3.06	B41231B6338M0*#
4700	22 ´ 40	0.30	7.58	3.83	B41231A6478M0*#
4700	25.4 ´ 35	0.30	7.88	3.98	B41231B6478M0*#
4700	30 ´ 25	0.30	7.64	3.86	B41231C6478M0*#
4700	35 ´ 25	0.30	8.30	4.19	B41231D6478M0*#
5600	22 ´ 45	0.30	8.43	4.26	B41231A6568M0*#
5600	25.4 ´ 40	0.30	8.79	4.44	B41231B6568M0*#
5600	30 ´ 30	0.30	8.61	4.35	B41231C6568M0*#
5600	35 ´ 25	0.30	8.79	4.44	B41231D6568M0*#
6800	22 ´ 50	0.30	9.44	4.77	B41231A6688M0*#
6800	25.4 ´ 45	0.30	9.42	4.76	B41231B6688M0*#
6800	30 ´ 35	0.30	9.74	4.92	B41231C6688M0*#
6800	35 ´ 30	0.30	9.98	5.04	B41231D6688M0*#
8200	25.4 ´ 50	0.30	10.75	5.43	B41231A6828M0*#
8200	30 ´ 40	0.30	10.65	5.38	B41231B6828M0*#
8200	35 ´ 30	0.30	10.41	5.26	B41231C6828M0*#
10000	30 ´ 45	0.30	12.02	6.07	B41231A6109M0*#
10000	35 ´ 35	0.30	11.82	5.97	B41231B6109M0*#
12000	30 ´ 50	0.30	13.11	6.62	B41231A6129M0*#
12000	35 ´ 40	0.30	12.97	6.55	B41231B6129M0*#
15000	35 ´ 45	0.30	14.26	7.20	B41231A6159M0*#
18000	35 ´ 50	0.30	15.33	7.74	B41231A6189M0*#
$V_R = 63 \text{ V DC}$					
1800	22 ´ 25	0.25	4.36	2.20	B41231A8188M0*#
2200	22 ´ 30	0.25	4.95	2.50	B41231A8228M0*#
2200	25.4 ´ 25	0.25	5.11	2.58	B41231B8228M0*#
2700	22 ´ 35	0.25	5.82	2.94	B41231A8278M0*#
2700	25.4 ´ 30	0.25	6.02	3.04	B41231B8278M0*#
3300	22 ´ 35	0.25	6.22	3.14	B41231A8338M0*#
3300	25.4 ´ 30	0.25	6.45	3.26	B41231B8338M0*#
3300	30 ´ 25	0.25	6.61	3.34	B41231C8338M0*#

Composition of ordering code

* = Insulation feature

0 = PVC insulation

6 = PET insulation

= Terminal style

0 = snap-in standard terminals (6.0 ±1 mm)

2 = snap-in 3 terminals (4.5 ±1 mm)

7 = snap-in short terminals (4.5 ±1 mm)



Technical data and ordering codes

C_R 120 Hz 20 °C nF	Case dimensions d × l mm	$\tan \delta_{\max}$ 120 Hz 20 °C	$I_{AC,\max}$ 120 Hz 60 °C A	$I_{AC,R}$ 120 Hz 85 °C A	Ordering code (composition see below)
$V_R = 63 \text{ V DC}$					
3900	22 × 40	0.25	7.13	3.60	B41231A8398M0*#
3900	25.4 × 35	0.25	7.41	3.74	B41231B8398M0*#
3900	30 × 30	0.25	7.62	3.85	B41231C8398M0*#
4700	22 × 50	0.25	8.30	4.19	B41231A8478M0*#
4700	25.4 × 40	0.25	8.30	4.19	B41231B8478M0*#
4700	30 × 35	0.25	8.12	4.10	B41231C8478M0*#
4700	35 × 30	0.25	8.30	4.19	B41231D8478M0*#
5600	25.4 × 45	0.25	9.21	4.65	B41231A8568M0*#
5600	30 × 35	0.25	9.07	4.58	B41231B8568M0*#
5600	35 × 30	0.25	9.31	4.70	B41231C8568M0*#
6800	25.4 × 50	0.25	10.30	5.20	B41231A8688M0*#
6800	30 × 40	0.25	10.22	5.16	B41231B8688M0*#
6800	35 × 30	0.25	9.98	5.04	B41231C8688M0*#
8200	30 × 45	0.25	11.13	5.62	B41231A8828M0*#
8200	35 × 35	0.25	10.95	5.53	B41231B8828M0*#
10000	30 × 50	0.25	12.51	6.32	B41231A8109M0*#
10000	35 × 40	0.25	12.38	6.25	B41231B8109M0*#
12000	35 × 45	0.25	13.52	6.83	B41231A8129M0*#
$V_R = 80 \text{ V DC}$					
1200	22 × 25	0.20	4.44	2.24	B41231A0128M0*#
1500	22 × 30	0.20	5.29	2.67	B41231A0158M0*#
1800	22 × 30	0.20	5.78	2.92	B41231A0188M0*#
1800	25.4 × 25	0.20	5.96	3.01	B41231B0188M0*#
2200	22 × 35	0.25	6.44	3.25	B41231A0228M0*#
2200	25.4 × 30	0.20	6.65	3.36	B41231B0228M0*#
2200	30 × 25	0.20	6.83	3.45	B41231C0228M0*#
2700	22 × 40	0.20	7.50	3.79	B41231A0278M0*#
2700	25.4 × 35	0.20	7.80	3.94	B41231B0278M0*#
2700	30 × 30	0.20	8.02	4.05	B41231C0278M0*#
3300	22 × 45	0.20	8.28	4.18	B41231A0338M0*#
3300	25.4 × 40	0.20	8.63	4.36	B41231B0338M0*#
3300	30 × 30	0.20	8.45	4.27	B41231C0338M0*#

Composition of ordering code

* = Insulation feature
 0 = PVC insulation
 6 = PET insulation

= Terminal style
 0 = snap-in standard terminals (6.0 ± 1 mm)
 2 = snap-in 3 terminals (4.5 ± 1 mm)
 7 = snap-in short terminals (4.5 ± 1 mm)



B41231

Standard series 85 °C

Technical data and ordering codes

C_R 120 Hz 20 °C nF	Case dimensions d ´ l mm	$\tan \delta_{max}$ 120 Hz 20 °C	$I_{AC,max}$ 120 Hz 60 °C A	$I_{AC,R}$ 120 Hz 85 °C A	Ordering code (composition see below)
$V_R = 80 \text{ V DC}$					
3900	22 ´ 50	0.25	9.41	4.75	B41231A0398M0*#
3900	25.4 ´ 45	0.20	9.82	4.96	B41231B0398M0*#
3900	30 ´ 35	0.20	9.68	4.89	B41231C0398M0*#
4700	25.4 ´ 50	0.20	10.77	5.44	B41231A0478M0*#
4700	30 ´ 40	0.20	10.67	5.39	B41231B0478M0*#
4700	35 ´ 30	0.20	10.43	5.27	B41231C0478M0*#
5600	30 ´ 45	0.20	11.70	5.91	B41231A0568M0*#
5600	35 ´ 35	0.20	11.50	5.81	B41231B0568M0*#
6800	35 ´ 40	0.20	10.81	5.46	B41231A0688M0*#
8200	35 ´ 45	0.20	13.68	6.91	B41231A0828M0*#
$V_R = 100 \text{ V DC}$					
1200	22 ´ 30	0.15	4.73	2.39	B41231A9128M0*#
1200	25.4 ´ 25	0.15	4.87	2.46	B41231B9128M0*#
1500	22 ´ 35	0.15	5.60	2.83	B41231A9158M0*#
1500	25.4 ´ 30	0.15	5.80	2.93	B41231B9158M0*#
1500	30 ´ 25	0.15	5.94	3.00	B41231C9158M0*#
1800	22 ´ 40	0.15	6.45	3.26	B41231A9188M0*#
1800	25.4 ´ 35	0.15	6.71	3.39	B41231B9188M0*#
1800	30 ´ 30	0.15	6.91	3.49	B41231C9188M0*#
2200	22 ´ 45	0.15	7.09	3.58	B41231A9228M0*#
2200	25.4 ´ 40	0.15	7.41	3.74	B41231B9228M0*#
2200	30 ´ 30	0.15	7.25	3.66	B41231C9228M0*#
2700	25.4 ´ 45	0.15	8.57	4.33	B41231A9278M0*#
2700	30 ´ 35	0.15	8.45	4.27	B41231B9278M0*#
2700	35 ´ 30	0.15	8.65	4.37	B41231C9278M0*#
3300	25.4 ´ 50	0.15	9.42	4.76	B41231A9338M0*#
3300	30 ´ 40	0.15	9.35	4.72	B41231B9338M0*#
3300	35 ´ 35	0.15	9.60	4.85	B41231C9338M0*#
3900	30 ´ 45	0.15	10.61	5.36	B41231A9398M0*#
3900	35 ´ 35	0.15	10.43	5.27	B41231B9398M0*#
4700	30 ´ 50	0.15	11.60	5.86	B41231A9478M0*#
4700	35 ´ 40	0.15	11.48	5.80	B41231B9478M0*#
5600	35 ´ 45	0.15	12.55	6.34	B41231A9568M0*#

Composition of ordering code

- * = Insulation feature
 0 = PVC insulation
 6 = PET insulation

- # = Terminal style
 0 = snap-in standard terminals (6.0 ±1 mm)
 2 = snap-in 3 terminals (4.5 ±1 mm)
 7 = snap-in short terminals (4.5 ±1 mm)



Useful life

depending on ambient temperature T_A under ripple current operating conditions¹⁾

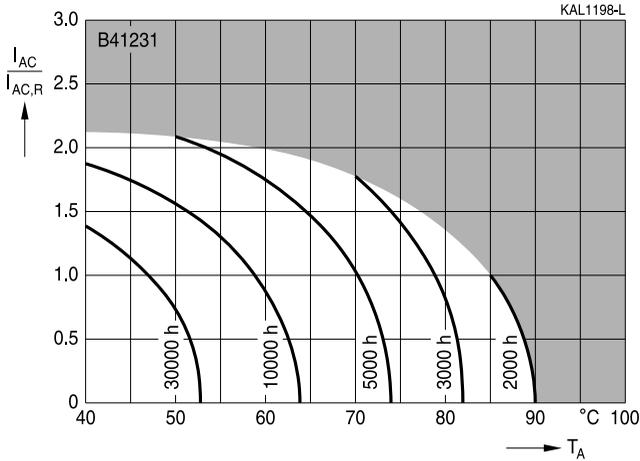

Frequency factor of permissible ripple current I_{AC} versus frequency f

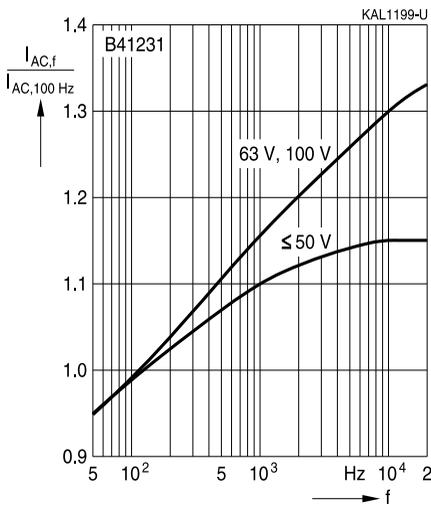

Frequency characteristics of ESR
Typical behavior

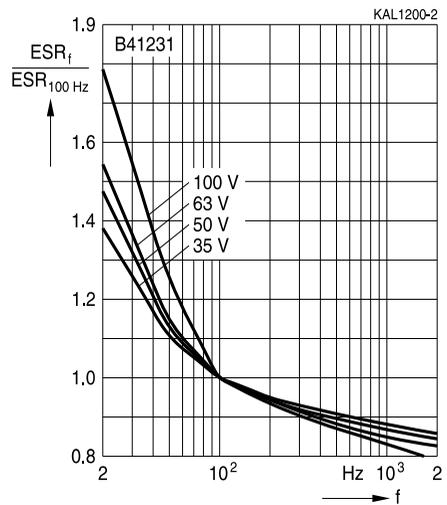

1) Refer to chapter "General technical information, 5.3 Calculation of useful life" for an explanation on how to interpret the useful life graphs.



B41231

Standard series 85 °C

Impedance Z versus frequency f
 Typical behavior at 20 °C

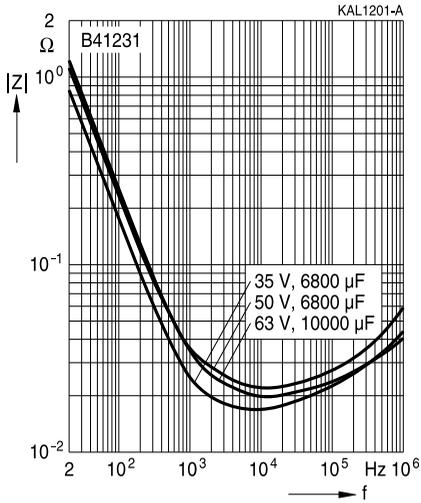



Cautions and warnings

Personal safety

The electrolytes used by EPCOS have not only been optimized with a view to the intended application, but also with regard to health and environmental compatibility. They do not contain any solvents that are detrimental to health, e.g. dimethyl formamide (DMF) or dimethyl acetamide (DMAC).

Furthermore, part of the high-voltage electrolytes used by EPCOS are self-extinguishing. They contain flame-retarding substances which will quickly extinguish any flame that may have been ignited.

As far as possible, EPCOS does not use any dangerous chemicals or compounds to produce operating electrolytes. However, in exceptional cases, such materials must be used in order to achieve specific physical and electrical properties because no safe substitute materials are currently known. However, the amount of dangerous materials used in our products has been limited to an absolute minimum. Nevertheless, the following rules should be observed when handling aluminum electrolytic capacitors:

- Any escaping electrolyte should not come into contact with eyes or skin.
- If electrolyte does come into contact with the skin, wash the affected parts immediately with running water. If the eyes are affected, rinse them for 10 minutes with plenty of water. If symptoms persist, seek medical treatment.
- Avoid breathing in electrolyte vapor or mists. Workplaces and other affected areas should be well ventilated. Clothing that has been contaminated by electrolyte must be changed and rinsed in water.



B41231

Standard series 85 °C

Product safety

The table below summarizes the safety instructions that must be observed without fail. A detailed description can be found in the relevant sections of chapter "General technical information".

Topic	Safety information	Reference chapter "General technical information"
Polarity	Make sure that polar capacitors are connected with the right polarity.	1 "Basic construction of aluminum electrolytic capacitors"
Reverse voltage	Voltages polarity classes should be prevented by connecting a diode.	3.1.6 "Reverse voltage"
Upper category temperature	Do not exceed the upper category temperature.	7.2 "Maximum permissible operating temperature"
Maintenance	Make periodic inspections of the capacitors. Before the inspection, make sure that the power supply is turned off and carefully discharge the electricity of the capacitors. Do not apply any mechanical stress to the capacitor terminals.	10 "Maintenance"
Mounting position of screw-terminal capacitors	Do not mount the capacitor with the terminals (safety vent) upside down.	11.1. "Mounting positions of capacitors with screw terminals"
Mounting of single-ended capacitors	The internal structure of single-ended capacitors might be damaged if excessive force is applied to the lead wires. Avoid any compressive, tensile or flexural stress. Do not move the capacitor after soldering to PC board. Do not pick up the PC board by the soldered capacitor. Do not insert the capacitor on the PC board with a hole space different to the lead space specified.	11.4 "Mounting considerations for single-ended capacitors"
Robustness of terminals	The following maximum tightening torques must not be exceeded when connecting screw terminals: M5: 2 Nm M6: 2.5 Nm	11.3 "Mounting torques"
Soldering	Do not exceed the specified time or temperature limits during soldering.	11.5 "Soldering"



Topic	Safety information	Reference chapter "General technical information"
Soldering, cleaning agents	Do not allow halogenated hydrocarbons to come into contact with aluminum electrolytic capacitors.	11.6 "Cleaning agents"
Passive flammability	Avoid external energy, such as fire or electricity.	8.1 "Passive flammability"
Active flammability	Avoid overload of the capacitors.	8.2 "Active flammability"
		Reference chapter "Capacitors with screw terminals"
Breakdown strength of insulating sleeves	Do not damage the insulating sleeve, especially when ring clips are used for mounting.	"Screw terminals accessories"

B41231
Standard series 85 °C
Symbols and terms

Symbol	English	German
C	Capacitance	Kapazität
C_R	Rated capacitance	Nennkapazität
C_S	Series capacitance	Serienkapazität
$C_{S,T}$	Series capacitance at temperature T	Serienkapazität bei Temperatur T
C_f	Capacitance at frequency f	Kapazität bei Frequenz f
d	Case diameter, nominal dimension	Gehäusedurchmesser, Nennmaß
d_{max}	Maximum case diameter	Maximaler Gehäusedurchmesser
ESL	Self-inductance	Eigeninduktivität
ESR	Equivalent series resistance	Ersatzserienwiderstand
ESR_f	Equivalent series resistance at frequency f	Ersatzserienwiderstand bei Frequenz f
ESR_T	Equivalent series resistance at temperature T	Ersatzserienwiderstand bei Temperatur T
f	Frequency	Frequenz
I	Current	Strom
I_{AC}	Alternating current (ripple current)	Wechselstrom
$I_{AC,rms}$	Root-mean-square value of alternating current	Wechselstrom, Effektivwert
$I_{AC,f}$	Ripple current at frequency f	Wechselstrom bei Frequenz f
$I_{AC,max}$	Maximum permissible ripple current	Maximal zulässiger Wechselstrom
$I_{AC,R}$	Rated ripple current	Nennwechselstrom
$I_{AC,R} (B)$	Rated ripple current for base cooling	Nennwechselstromstrom für Bodenkühlung
I_{leak}	Leakage current	Reststrom
$I_{leak,op}$	Operating leakage current	Betriebsreststrom
l	Case length, nominal dimension	Gehäuselänge, Nennmaß
l_{max}	Maximum case length (without terminals and mounting stud)	Maximale Gehäuselänge (ohne Anschlüsse und Gewindebolzen)
R	Resistance	Widerstand
R_{ins}	Insulation resistance	Isolationswiderstand
R_{symm}	Balancing resistance	Symmetrierwiderstand
T	Temperature	Temperatur
DT	Temperature difference	Temperaturdifferenz
T_A	Ambient temperature	Umgebungstemperatur
T_C	Case temperature	Gehäusetemperatur
T_B	Capacitor base temperature	Temperatur des Becherbodens
t	Time	Zeit
Dt	Period	Zeitraum
t_b	Service life (operating hours)	Brauchbarkeitsdauer (Betriebszeit)



Symbol	English	German
V	Voltage	Spannung
V _F	Forming voltage	Formierspannung
V _{op}	Operating voltage	Betriebsspannung
V _R	Rated voltage, DC voltage	Nennspannung, Gleichspannung
V _S	Surge voltage	Spitzenspannung
X _C	Capacitive reactance	Kapazitiver Blindwiderstand
X _L	Inductive reactance	Induktiver Blindwiderstand
Z	Impedance	Scheinwiderstand
Z _T	Impedance at temperature T	Scheinwiderstand bei Temperatur T
tan d	Dissipation factor	Verlustfaktor
l	Failure rate	Ausfallrate
ε ₀	Absolute permittivity	Elektrische Feldkonstante
ε _r	Relative permittivity	Dielektrizitätszahl
w	Angular velocity; 2 π f	Kreisfrequenz; 2 π f

Note

All dimensions are given in mm.

The following applies to all products named in this publication:

1. Some parts of this publication contain statements about the suitability of our products for certain areas of application. These statements are based on our knowledge of typical requirements that are often placed on our products in the areas of application concerned. We nevertheless expressly point out that such statements cannot be regarded as binding statements about the suitability of our products for a particular customer application. As a rule, EPCOS is either unfamiliar with individual customer applications or less familiar with them than the customers themselves. For these reasons, it is always ultimately incumbent on the customer to check and decide whether an EPCOS product with the properties described in the product specification is suitable for use in a particular customer application.
2. We also point out that in individual cases, a malfunction of electronic components or failure before the end of their usual service life cannot be completely ruled out in the current state of the art, even if they are operated as specified. In customer applications requiring a very high level of operational safety and especially in customer applications in which the malfunction or failure of an electronic component could endanger human life or health (e.g. in accident prevention or lifesaving systems), it must therefore be ensured by means of suitable design of the customer application or other action taken by the customer (e.g. installation of protective circuitry or redundancy) that no injury or damage is sustained by third parties in the event of malfunction or failure of an electronic component.
3. The warnings, cautions and product-specific notes must be observed.
4. In order to satisfy certain technical requirements, some of the products described in this publication may contain substances subject to restrictions in certain jurisdictions (e.g. because they are classed as hazardous). Useful information on this will be found in our Material Data Sheets on the Internet (www.epcos.com/material). Should you have any more detailed questions, please contact our sales offices.
5. We constantly strive to improve our products. Consequently, the products described in this publication may change from time to time. The same is true of the corresponding product specifications. Please check therefore to what extent product descriptions and specifications contained in this publication are still applicable before or when you place an order. We also reserve the right to discontinue production and delivery of products. Consequently, we cannot guarantee that all products named in this publication will always be available. The aforementioned does not apply in the case of individual agreements deviating from the foregoing for customer-specific products.
6. Unless otherwise agreed in individual contracts, all orders are subject to the current version of the "General Terms of Delivery for Products and Services in the Electrical Industry" published by the German Electrical and Electronics Industry Association (ZVEI).
7. The trade names EPCOS, BAOKE, Alu-X, CeraDiode, CSMP, CSSP, CTVS, DeltaCap, DigiSiMic, DSSP, FormFit, MiniBlue, MiniCell, MKK, MKD, MLSC, MotorCap, PCC, PhaseCap, PhaseCube, PhaseMod, PhiCap, SIFERRIT, SIFI, SIKOREL, SilverCap, SIMDAD, SiMic, SIMID, SineFormer, SIOV, SIP5D, SIP5K, ThermoFuse, WindCap are trademarks registered or pending in Europe and in other countries. Further information will be found on the Internet at www.epcos.com/trademarks.