



Aluminum electrolytic capacitors

Snap-in capacitors

Series/Type: B43305

Date: December 2010

General-purpose grade capacitors

Applications

- Switch-mode power supplies in industrial and entertainment electronics
- Uninterruptible power supplies

Features

- Voltage derating ($0.93 V_R$) enables 105 °C operation, more details available upon request
- Extremely high CV product, ultra compact
- High ripple current capability
- Different case sizes available for each capacitance value
- Capacitors with all insulation versions pass the needle flame test according to IEC 60695-11-5 for all flame exposure times up to 120 s
- RoHS-compatible

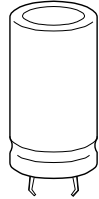

Construction

- Charge/discharge-proof, polar
- Aluminum case, fully insulated with PVC
- Version with PET insulation available
- Version with additional PET insulation cap on terminal side available for insulating the capacitor from the PCB
- Snap-in solder pins to hold component in place on PC-board
- Minus pole marking on case surface
- Minus pole not insulated from case
- Overload protection by safety vent on the base

Terminals

- Standard version with 2 terminals, 2 lengths available: 6.3 and 4.5 mm
- 3 terminals to ensure correct insertion: length 4.5 mm



Specifications and characteristics in brief

Rated voltage V_R	200 ... 450 V DC										
Surge voltage V_S	1.15 V_R (for V_R £ 250 V DC) 1.10 V_R (for V_R ³ 400 V DC)										
Rated capacitance C_R	68 ... 3300 μ F										
Capacitance tolerance	±20% M										
Dissipation factor tan d (20 °C, 120 Hz)	V_R £ 250 V DC: tan d £ 0.15 V_R ³ 400 V DC: tan d £ 0.20										
Leakage current I_{leak} (5 min, 20 °C)	$I_{leak} \leq 0.3 \mu A \cdot \left(\frac{C_R}{\mu F} \cdot \frac{V_R}{V} \right)^{0.7} + 4 \mu A$										
Self-inductance ESL	Approx. 20 nH										
Useful life 85 °C; V_R ; $I_{AC,R}$ 40 °C; V_R ; 1.1 $I_{AC,R}$	> 2000 h > 100000 h	Requirements: DC/C £ ±30% of initial value tan d £ 3 times initial specified limit I_{leak} £ initial specified limit									
Voltage endurance test 85 °C; V_R	2000 h	Post test requirements: DC/C £ ±10% of initial value tan d £ 1.3 times initial specified limit I_{leak} £ initial specified limit									
Vibration resistance test	To IEC 60068-2-6, test Fc: Frequency range 10 Hz ... 55 Hz, displacement amplitude 0.35 mm, acceleration max. 5 g, duration 3 ´ 2 h. Capacitor mounted by its body which is rigidly clamped to the work surface.										
Characteristics at low temperature	Max. impedance ratio at 100 Hz	<table border="1"> <thead> <tr> <th>V_R</th> <th>£ 250 V</th> <th>³ 400 V</th> </tr> </thead> <tbody> <tr> <td>$Z_{-25^\circ C} / Z_{20^\circ C}$</td> <td>3</td> <td>7</td> </tr> <tr> <td>$Z_{-40^\circ C} / Z_{20^\circ C}$</td> <td>7</td> <td>14</td> </tr> </tbody> </table>	V_R	£ 250 V	³ 400 V	$Z_{-25^\circ C} / Z_{20^\circ C}$	3	7	$Z_{-40^\circ C} / Z_{20^\circ C}$	7	14
V_R	£ 250 V	³ 400 V									
$Z_{-25^\circ C} / Z_{20^\circ C}$	3	7									
$Z_{-40^\circ C} / Z_{20^\circ C}$	7	14									
IEC climatic category	To IEC 60068-1: ■ V_R £ 250 V DC: 40/085/56 (40 °C/+85 °C/56 days damp heat test) ■ V_R ³ 400 V DC: 25/085/56 (25 °C/+85 °C/56 days damp heat test) The capacitors can be operated in the temperature range of 40 °C to +85 °C but the impedance at 40 °C should be taken into consideration.										
Detail specification	Similar to CECC 30301-806										
Sectional specification	IEC 60384-4										



B43305

Ultra compact 85 °C

Dimensional drawings

Snap-in capacitors with standard insulation (PVC or PET)

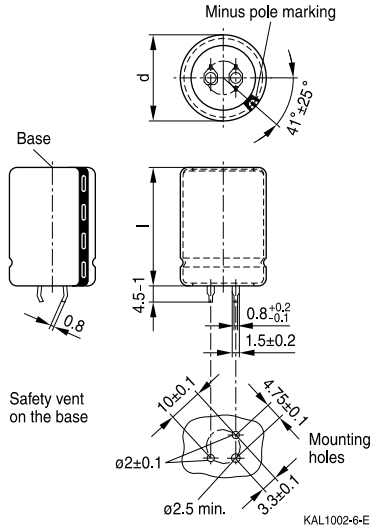
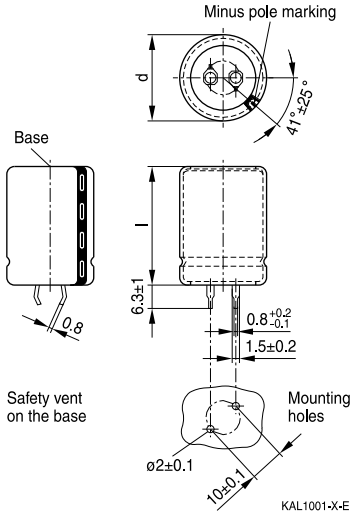

Snap-in terminals, length (6.3 ± 1) mm. Also available in a shorter version with a length of (4.5 ± 1) mm. PET insulation is marked with label "PET" on the sleeve.

Snap-in capacitors are also available with 3 terminals (length (4.5 ± 1) mm). PET insulation is marked with label "PET" on the sleeve.

Dimensions (mm)		Approx. weight (g)	Packing units (pcs.)
d +1	l ±2		
22	25	9	160
22	30	12	160
22	35	15	160
22	40	18	160
22	45	20	160
22	50	24	160
25	25	13	130
25	30	17	130
25	35	19	130
25	40	22	130
25	45	25	130
25	50	29	130
25	55	32	130

Dimensions (mm)		Approx. weight (g)	Packing units (pcs.)
d +1	l ±2		
30	25	17	80
30	30	23	80
30	35	29	80
30	40	36	80
30	45	41	80
30	50	46	80
30	55	53	80
35	25	22	60
35	30	29	60
35	35	36	60
35	40	41	60
35	45	56	60
35	50	70	60
35	55	81	60



Snap-in capacitors with PVC insulation and PET insulation cap on terminal side

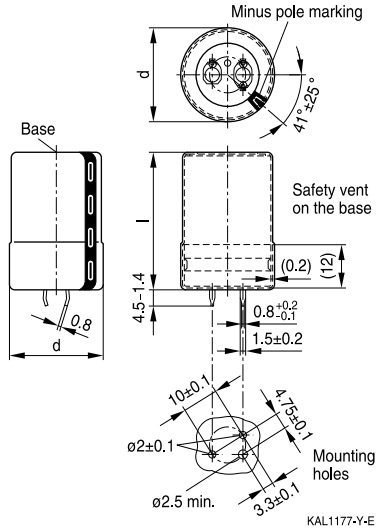
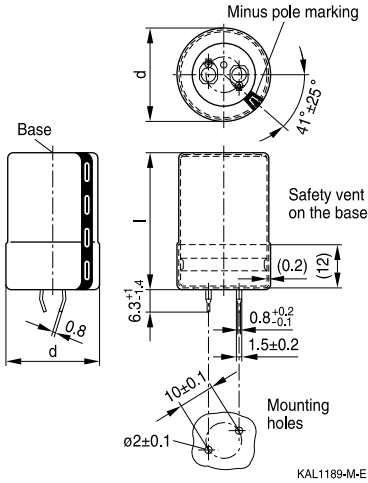

Snap-in terminals, length (6.3 +1/ 1.4) mm. Also available in a shorter version with a length of (4.5 1.4) mm. PET insulation cap is positioned under the insulation sleeve.

Snap-in capacitors are also available with 3 terminals (length (4.5 1.4) mm). PET insulation cap is positioned under the insulation sleeve.

Dimensions (mm)		Approx. weight (g)	Packing units (pcs.)
d +1.4	l +2.2/ 2		
22	25	9	160
22	30	12	160
22	35	15	160
22	40	18	160
22	45	20	160
22	50	24	160
25	25	13	130
25	30	17	130
25	35	19	130
25	40	22	130
25	45	25	130
25	50	29	130
25	55	32	130

Dimensions (mm)		Approx. weight (g)	Packing units (pcs.)
d +1.4	l +2.2/ 2		
30	25	17	80
30	30	23	80
30	35	29	80
30	40	36	80
30	45	41	80
30	50	46	80
30	55	53	80
35	25	22	60
35	30	29	60
35	35	36	60
35	40	41	60
35	45	56	60
35	50	70	60
35	55	81	60

B43305
Ultra compact 85 °C
Packing of snap-in capacitors

For ecological reasons the packing is pure cardboard. Components can be withdrawn (in full or in part) in the correct position for insertion.

Ordering codes for terminal styles and insulation features
Identification in 3rd block of ordering code
Snap-in capacitors

Terminal version	Insulation version		
	PVC	PET	PVC plus PET cap
Standard terminals 6.3 mm	M000	M060	M080
Short terminals 4.5 mm	M007	M067	M087
3 terminals 4.5 mm	M002	M062	M082

Ordering examples:

- B43305A9107M007 } snap-in capacitor with short terminals and standard PVC insulation
- B43305A9107M062 } snap-in capacitor with 3 terminals and PET insulation
- B43305A9107M080 } snap-in capacitor with standard terminals and PVC insulation with additional PET insulation cap on terminal side

Overview of available types

V_R (V DC)	200	250	400	450
	Case dimensions d ´ l (mm)			
C_R (nF)				
68			22 ´ 25	22 ´ 25
82			22 ´ 25	22 ´ 25
100			22 ´ 25	22 ´ 25
120			22 ´ 25	22 ´ 30 25 ´ 25
150			22 ´ 30	22 ´ 35 25 ´ 30
180			22 ´ 30 25 ´ 25	22 ´ 40 25 ´ 30 30 ´ 25
220			22 ´ 35 25 ´ 30	22 ´ 45 25 ´ 35 30 ´ 30
270		22 ´ 25	22 ´ 45 25 ´ 35 30 ´ 25	22 ´ 50 25 ´ 40 30 ´ 30 35 ´ 25
330	22 ´ 25	22 ´ 30 25 ´ 25	22 ´ 50 25 ´ 40 30 ´ 30 35 ´ 25	25 ´ 50 30 ´ 35 35 ´ 30
390	22 ´ 25	22 ´ 30 25 ´ 25	25 ´ 45 30 ´ 35 35 ´ 30	25 ´ 55 30 ´ 40 35 ´ 30
470	22 ´ 30 25 ´ 25	22 ´ 35 25 ´ 30	25 ´ 50 30 ´ 40 35 ´ 30	30 ´ 45 35 ´ 35
560	22 ´ 35 25 ´ 30	22 ´ 40 25 ´ 35 30 ´ 25	30 ´ 45 35 ´ 35	30 ´ 50 35 ´ 40
680	22 ´ 40 25 ´ 30 30 ´ 25	22 ´ 45 25 ´ 40 30 ´ 30	30 ´ 50 35 ´ 40	35 ´ 45
820	22 ´ 45 25 ´ 35 30 ´ 30	25 ´ 45 30 ´ 35 35 ´ 25	30 ´ 55 35 ´ 45	35 ´ 55



B43305

Ultra compact 85 °C

V _R (V DC)	200	250	400	450
	Case dimensions d × l (mm)			
C _R (nF)				
1000	22 × 50 25 × 40 30 × 30 35 × 25	25 × 50 30 × 35 35 × 30	35 × 50	
1200	25 × 45 30 × 35 35 × 30	25 × 55 30 × 40 35 × 35		
1500	25 × 55 30 × 40 35 × 30	30 × 50 35 × 40		
1800	30 × 45 35 × 35	30 × 55 35 × 45		
2200	30 × 55 35 × 40	35 × 50		
2700	35 × 50			
3300	35 × 55			

The capacitance and voltage ratings listed above are available in different cases upon request. Other voltage and capacitance ratings are also available upon request.

Technical data and ordering codes

C_R 100 Hz 20 °C nF	Case dimensions d × l mm	ESR _{typ} 100 Hz 20 °C mW	Z _{max} 10 kHz 20 °C mW	I _{AC,max} 100 Hz 60 °C A	I _{AC,R} ¹⁾ 100 Hz 85 °C A	Ordering code (composition see below)
V_R = 200 V DC						
330	22 × 25	380	520	2.72	1.38	B43305A2337M0*#
390	22 × 25	320	440	2.95	1.50	B43305A2397M0*#
470	22 × 30	270	370	3.38	1.72	B43305A2477M0*#
470	25 × 25	270	370	3.33	1.70	B43305B2477M0*#
560	22 × 35	230	310	3.82	1.95	B43305A2567M0*#
560	25 × 30	230	310	3.79	1.93	B43305B2567M0*#
680	22 × 40	190	260	4.34	2.21	B43305A2687M0*#
680	25 × 30	190	260	4.18	2.13	B43305B2687M0*#
680	30 × 25	190	260	3.82	1.95	B43305C2687M0*#
820	22 × 45	150	210	4.90	2.50	B43305A2827M0*#
820	25 × 35	150	210	4.76	2.42	B43305B2827M0*#
820	30 × 30	150	210	4.37	2.23	B43305C2827M0*#
1000	22 × 50	130	180	5.54	2.83	B43305A2108M0*#
1000	25 × 40	130	180	5.42	2.76	B43305B2108M0*#
1000	30 × 30	130	180	4.83	2.46	B43305C2108M0*#
1000	35 × 25	130	180	4.11	2.09	B43305D2108M0*#
1200	25 × 45	110	150	6.10	3.11	B43305A2128M0*#
1200	30 × 35	110	150	5.48	2.79	B43305B2128M0*#
1200	35 × 30	110	150	4.99	2.54	B43305C2128M0*#
1500	25 × 55	85	120	7.15	3.64	B43305A2158M0*#
1500	30 × 40	85	120	6.74	3.44	B43305B2158M0*#
1500	35 × 30	85	120	5.58	2.84	B43305C2158M0*#
1800	30 × 45	70	100	7.59	3.87	B43305A2188M0*#
1800	35 × 35	70	100	6.33	3.23	B43305B2188M0*#
2200	30 × 55	60	80	8.80	4.49	B43305A2228M0*#
2200	35 × 40	60	80	7.22	3.68	B43305B2228M0*#
2700	35 × 50	45	65	8.44	4.30	B43305A2278M0*#
3300	35 × 55	40	55	9.55	4.87	B43305A2338M0*#

Composition of ordering code

* = Insulation feature

0 = PVC insulation

6 = PET insulation

 8 = PVC insulation with additional PET insulation
cap on terminal side

= Terminal style

0 = snap-in standard terminals (6.3 mm)

2 = snap-in 3 terminals (4.5 mm)

7 = snap-in short terminals (4.5 mm)

 1) 120-Hz conversion factor of ripple current: I_{AC} (120 Hz) = 1.03 I_{AC} (100 Hz)



B43305

Ultra compact 85 °C

Technical data and ordering codes

C_R 100 Hz 20 °C nF	Case dimensions d ´ l mm	ESR _{typ} 100 Hz 20 °C mW	Z_{max} 10 kHz 20 °C mW	$I_{AC,max}$ 100 Hz 60 °C A	$I_{AC,R^{(2)}}$ 100 Hz 85 °C A	Ordering code (composition see below)
$V_R = 250$ V DC						
270	22 ´ 25	470	640	2.61	1.33	B43305E2277M0*#
330	22 ´ 30	380	520	3.01	1.53	B43305E2337M0*#
330	25 ´ 25	380	520	2.95	1.50	B43305F2337M0*#
390	22 ´ 30	320	440	3.27	1.67	B43305E2397M0*#
390	25 ´ 25	320	440	3.21	1.64	B43305F2397M0*#
470	22 ´ 35	270	370	3.72	1.90	B43305E2477M0*#
470	25 ´ 30	270	370	3.68	1.87	B43305F2477M0*#
560	22 ´ 40	230	310	4.19	2.13	B43305E2567M0*#
560	25 ´ 35	230	310	4.16	2.12	B43305F2567M0*#
560	30 ´ 25	230	310	3.62	1.84	B43305G2567M0*#
680	22 ´ 45	190	260	4.74	2.42	B43305E2687M0*#
680	25 ´ 40	190	260	4.73	2.41	B43305F2687M0*#
680	30 ´ 30	190	260	4.15	2.12	B43305G2687M0*#
820	25 ´ 45	150	210	5.34	2.72	B43305E2827M0*#
820	30 ´ 35	150	210	4.73	2.41	B43305F2827M0*#
820	35 ´ 25	150	210	3.82	1.95	B43305G2827M0*#
1000	25 ´ 50	130	180	6.04	3.08	B43305E2108M0*#
1000	30 ´ 35	130	180	5.22	2.66	B43305F2108M0*#
1000	35 ´ 30	130	180	4.69	2.39	B43305G2108M0*#
1200	25 ´ 55	110	150	6.77	3.45	B43305E2128M0*#
1200	30 ´ 40	110	150	6.29	3.21	B43305F2128M0*#
1200	35 ´ 35	110	150	5.32	2.71	B43305G2128M0*#
1500	30 ´ 50	85	120	7.41	3.78	B43305E2158M0*#
1500	35 ´ 40	85	120	6.13	3.13	B43305F2158M0*#
1800	30 ´ 55	70	100	8.31	4.24	B43305E2188M0*#
1800	35 ´ 45	70	100	6.91	3.52	B43305F2188M0*#
2200	35 ´ 50	60	80	7.83	3.99	B43305E2228M0*#

Composition of ordering code

* = Insulation feature

0 = PVC insulation

6 = PET insulation

8 = PVC insulation with additional PET insulation
cap on terminal side

= Terminal style

0 = snap-in standard terminals (6.3 mm)

2 = snap-in 3 terminals (4.5 mm)

7 = snap-in short terminals (4.5 mm)

2) 120-Hz conversion factor of ripple current: $I_{AC}(120\text{ Hz}) = 1.03 \cdot I_{AC}(100\text{ Hz})$



Technical data and ordering codes

C_R 100 Hz 20 °C nF	Case dimensions d × l mm	ESR _{typ} 100 Hz 20 °C mW	Z _{max} 10 kHz 20 °C mW	I _{AC,max} 100 Hz 60 °C A	I _{AC,R} ³⁾ 100 Hz 85 °C A	Ordering code (composition see below)
$V_R = 400 \text{ V DC}$						
68	22 × 25	1990	2690	1.28	0.65	B43305A9686M0*#
82	22 × 25	1650	2230	1.41	0.72	B43305A9826M0*#
100	22 × 25	1360	1830	1.55	0.79	B43305A9107M0*#
120	22 × 25	1130	1530	1.70	0.87	B43305A9127M0*#
150	22 × 30	900	1220	1.98	1.01	B43305A9157M0*#
180	22 × 30	750	1020	2.17	1.11	B43305A9187M0*#
180	25 × 25	750	1020	2.18	1.11	B43305B9187M0*#
220	22 × 35	620	830	2.49	1.27	B43305A9227M0*#
220	25 × 30	620	830	2.51	1.28	B43305B9227M0*#
270	22 × 45	500	680	2.92	1.49	B43305A9277M0*#
270	25 × 35	500	680	2.89	1.47	B43305B9277M0*#
270	30 × 25	500	680	2.79	1.42	B43305C9277M0*#
330	22 × 50	410	560	3.31	1.69	B43305A9337M0*#
330	25 × 40	410	560	3.29	1.68	B43305B9337M0*#
330	30 × 30	410	560	3.22	1.64	B43305C9337M0*#
330	35 × 25	410	560	3.04	1.55	B43305D9337M0*#
390	25 × 45	350	470	3.68	1.87	B43305A9397M0*#
390	30 × 35	350	470	3.62	1.85	B43305B9397M0*#
390	35 × 30	350	470	3.67	1.87	B43305C9397M0*#
470	25 × 50	290	390	4.14	2.11	B43305A9477M0*#
470	30 × 40	290	390	4.37	2.23	B43305B9477M0*#
470	35 × 30	290	390	4.03	2.05	B43305C9477M0*#
560	30 × 45	240	330	4.91	2.50	B43305A9567M0*#
560	35 × 35	240	330	4.56	2.32	B43305B9567M0*#
680	30 × 50	200	270	5.55	2.83	B43305A9687M0*#
680	35 × 40	200	270	5.18	2.64	B43305B9687M0*#
820	30 × 55	170	230	6.23	3.18	B43305A9827M0*#
820	35 × 45	170	230	5.85	2.98	B43305B9827M0*#
1000	35 × 50	140	190	6.63	3.38	B43305A9108M0*#

Composition of ordering code

* = Insulation feature

0 = PVC insulation

6 = PET insulation

8 = PVC insulation with additional PET insulation
cap on terminal side

= Terminal style

0 = snap-in standard terminals (6.3 mm)

2 = snap-in 3 terminals (4.5 mm)

7 = snap-in short terminals (4.5 mm)

3) 120-Hz conversion factor of ripple current: $I_{AC}(120 \text{ Hz}) = 1.03 \cdot I_{AC}(100 \text{ Hz})$

B43305
Ultra compact 85 °C
Technical data and ordering codes

C_R 100 Hz 20 °C nF	Case dimensions d ´ l mm	ESR _{typ} 100 Hz 20 °C mW	Z _{max} 10 kHz 20 °C mW	I _{AC,max} 100 Hz 60 °C A	I _{AC,R} ⁴⁾ 100 Hz 85 °C A	Ordering code (composition see below)
V_R = 450 V DC						
68	22 ´ 25	1990	2800	1.37	0.70	B43305A5686M0*#
82	22 ´ 25	1650	2320	1.50	0.76	B43305A5826M0*#
100	22 ´ 25	1360	1900	1.66	0.85	B43305A5107M0*#
120	22 ´ 30	1130	1590	1.90	0.97	B43305A5127M0*#
120	25 ´ 25	1130	1590	1.90	0.97	B43305B5127M0*#
150	22 ´ 35	900	1270	2.20	1.12	B43305A5157M0*#
150	25 ´ 30	900	1270	2.21	1.13	B43305B5157M0*#
180	22 ´ 40	750	1060	2.48	1.26	B43305A5187M0*#
180	25 ´ 30	750	1060	2.42	1.23	B43305B5187M0*#
180	30 ´ 25	750	1060	2.49	1.27	B43305C5187M0*#
220	22 ´ 45	620	870	2.82	1.44	B43305A5227M0*#
220	25 ´ 35	620	870	2.78	1.41	B43305B5227M0*#
220	30 ´ 30	620	870	2.87	1.46	B43305C5227M0*#
270	22 ´ 50	500	710	3.20	1.63	B43305A5277M0*#
270	25 ´ 40	500	710	3.17	1.62	B43305B5277M0*#
270	30 ´ 30	500	710	3.18	1.62	B43305C5277M0*#
270	35 ´ 25	500	710	3.04	1.55	B43305D5277M0*#
330	25 ´ 50	410	580	3.70	1.88	B43305A5337M0*#
330	30 ´ 35	410	580	3.64	1.86	B43305B5337M0*#
330	35 ´ 30	410	580	3.73	1.90	B43305C5337M0*#
390	25 ´ 55	350	490	4.11	2.09	B43305A5397M0*#
390	30 ´ 40	350	490	4.36	2.22	B43305B5397M0*#
390	35 ´ 30	350	490	4.06	2.07	B43305C5397M0*#
470	30 ´ 45	290	410	4.92	2.51	B43305A5477M0*#
470	35 ´ 35	290	410	4.62	2.35	B43305B5477M0*#
560	30 ´ 50	240	340	5.50	2.81	B43305A5567M0*#
560	35 ´ 40	240	340	5.20	2.65	B43305B5567M0*#
680	35 ´ 45	200	280	5.89	3.00	B43305A5687M0*#
820	35 ´ 55	170	240	6.79	3.46	B43305A5827M0*#

Composition of ordering code

* = Insulation feature

0 = PVC insulation

6 = PET insulation

 8 = PVC insulation with additional PET insulation
cap on terminal side

= Terminal style

0 = snap-in standard terminals (6.3 mm)

2 = snap-in 3 terminals (4.5 mm)

7 = snap-in short terminals (4.5 mm)

 4) 120-Hz conversion factor of ripple current: I_{AC} (120 Hz) = 1.03 I_{AC} (100 Hz)



Useful life

depending on ambient temperature T_A under ripple current operating conditions¹⁾
 Voltage derating ($0.93 V_R$) enables 105 °C operation

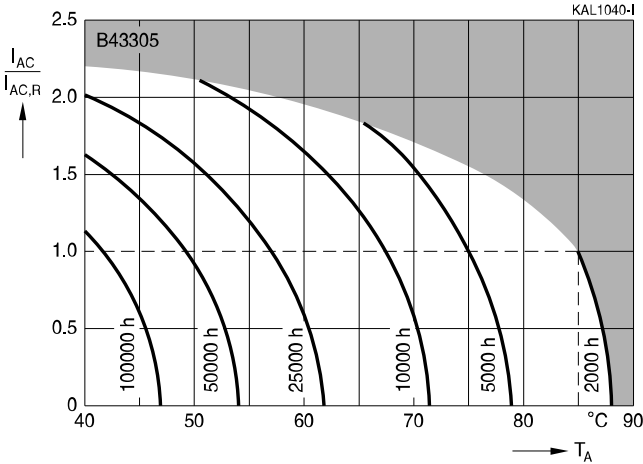

Frequency factor of permissible ripple current I_{AC} versus frequency f

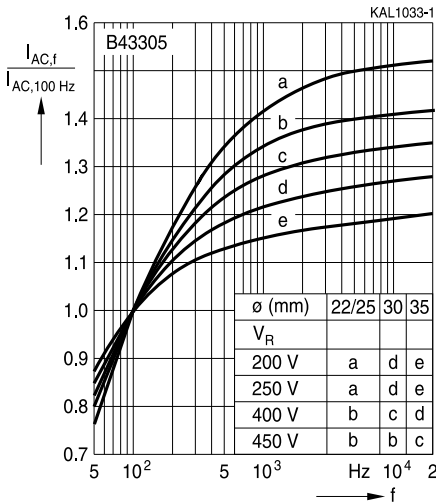

**Frequency characteristics of ESR
 Typical behavior**

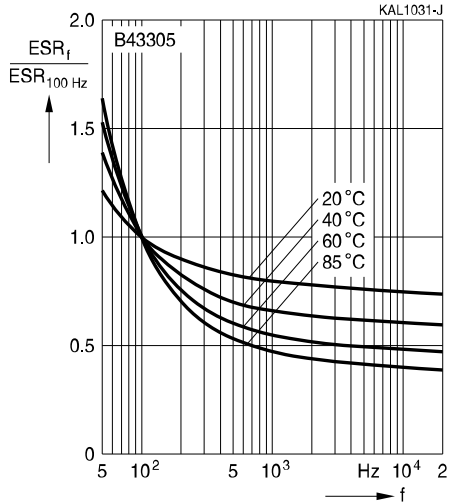

1) Refer to chapter "General technical information, 5.3 Calculation of useful life" for an explanation on how to interpret the useful life graphs.



B43305

Ultra compact 85 °C

Impedance Z versus frequency f
 Typical behavior at 20 °C

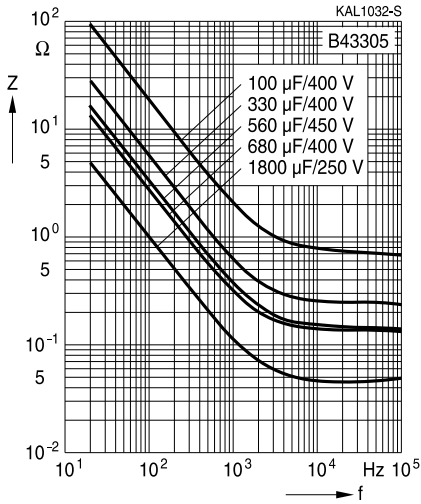



Cautions and warnings

Personal safety

The electrolytes used by EPCOS have not only been optimized with a view to the intended application, but also with regard to health and environmental compatibility. They do not contain any solvents that are detrimental to health, e.g. dimethyl formamide (DMF) or dimethyl acetamide (DMAC).

Furthermore, part of the high-voltage electrolytes used by EPCOS are self-extinguishing. They contain flame-retarding substances which will quickly extinguish any flame that may have been ignited.

As far as possible, EPCOS does not use any dangerous chemicals or compounds to produce operating electrolytes. However, in exceptional cases, such materials must be used in order to achieve specific physical and electrical properties because no safe substitute materials are currently known. However, the amount of dangerous materials used in our products has been limited to an absolute minimum. Nevertheless, the following rules should be observed when handling aluminum electrolytic capacitors:

- Any escaping electrolyte should not come into contact with eyes or skin.
- If electrolyte does come into contact with the skin, wash the affected parts immediately with running water. If the eyes are affected, rinse them for 10 minutes with plenty of water. If symptoms persist, seek medical treatment.
- Avoid breathing in electrolyte vapor or mists. Workplaces and other affected areas should be well ventilated. Clothing that has been contaminated by electrolyte must be changed and rinsed in water.



Product safety

The table below summarizes the safety instructions that must be observed without fail. A detailed description can be found in the relevant sections of chapter "General technical information".

Topic	Safety information	Reference chapter "General technical information"
Polarity	Make sure that polar capacitors are connected with the right polarity.	1 "Basic construction of aluminum electrolytic capacitors"
Reverse voltage	Voltages polarity classes should be prevented by connecting a diode.	3.1.6 "Reverse voltage"
Upper category temperature	Do not exceed the upper category temperature.	7.2 "Maximum permissible operating temperature"
Maintenance	Make periodic inspections of the capacitors. Before the inspection, make sure that the power supply is turned off and carefully discharge the electricity of the capacitors. Do not apply any mechanical stress to the capacitor terminals.	10 "Maintenance"
Mounting position of screw-terminal capacitors	Do not mount the capacitor with the terminals (safety vent) upside down.	11.1. "Mounting positions of capacitors with screw terminals"
Mounting of single-ended capacitors	The internal structure of single-ended capacitors might be damaged if excessive force is applied to the lead wires. Avoid any compressive, tensile or flexural stress. Do not move the capacitor after soldering to PC board. Do not pick up the PC board by the soldered capacitor. Do not insert the capacitor on the PC board with a hole space different to the lead space specified.	11.4 "Mounting considerations for single-ended capacitors"
Robustness of terminals	The following maximum tightening torques must not be exceeded when connecting screw terminals: M5: 2 Nm M6: 2.5 Nm	11.3 "Mounting torques"
Soldering	Do not exceed the specified time or temperature limits during soldering.	11.5 "Soldering"



Topic	Safety information	Reference chapter "General technical information"
Soldering, cleaning agents	Do not allow halogenated hydrocarbons to come into contact with aluminum electrolytic capacitors.	11.6 "Cleaning agents"
Passive flammability	Avoid external energy, such as fire or electricity.	8.1 "Passive flammability"
Active flammability	Avoid overload of the capacitors.	8.2 "Active flammability"
		Reference chapter "Capacitors with screw terminals"
Breakdown strength of insulating sleeves	Do not damage the insulating sleeve, especially when ring clips are used for mounting.	"Screw terminals accessories"

B43305
Ultra compact 85 °C
Symbols and terms

Symbol	English	German
C	Capacitance	Kapazität
C_R	Rated capacitance	Nennkapazität
C_S	Series capacitance	Serienkapazität
$C_{S,T}$	Series capacitance at temperature T	Serienkapazität bei Temperatur T
C_f	Capacitance at frequency f	Kapazität bei Frequenz f
d	Case diameter, nominal dimension	Gehäusedurchmesser, Nennmaß
d_{max}	Maximum case diameter	Maximaler Gehäusedurchmesser
ESL	Self-inductance	Eigeninduktivität
ESR	Equivalent series resistance	Ersatzserienwiderstand
ESR_f	Equivalent series resistance at frequency f	Ersatzserienwiderstand bei Frequenz f
ESR_T	Equivalent series resistance at temperature T	Ersatzserienwiderstand bei Temperatur T
f	Frequency	Frequenz
I	Current	Strom
I_{AC}	Alternating current (ripple current)	Wechselstrom
$I_{AC,rms}$	Root-mean-square value of alternating current	Wechselstrom, Effektivwert
$I_{AC,f}$	Ripple current at frequency f	Wechselstrom bei Frequenz f
$I_{AC,max}$	Maximum permissible ripple current	Maximal zulässiger Wechselstrom
$I_{AC,R}$	Rated ripple current	Nennwechselstrom
$I_{AC,R} (B)$	Rated ripple current for base cooling	Nennwechselstromstrom für Bodenkühlung
I_{leak}	Leakage current	Reststrom
$I_{leak,op}$	Operating leakage current	Betriebsreststrom
l	Case length, nominal dimension	Gehäuselänge, Nennmaß
l_{max}	Maximum case length (without terminals and mounting stud)	Maximale Gehäuselänge (ohne Anschlüsse und Gewindebolzen)
R	Resistance	Widerstand
R_{ins}	Insulation resistance	Isolationswiderstand
R_{symm}	Balancing resistance	Symmetrierwiderstand
T	Temperature	Temperatur
DT	Temperature difference	Temperaturdifferenz
T_A	Ambient temperature	Umgebungstemperatur
T_C	Case temperature	Gehäusetemperatur
T_B	Capacitor base temperature	Temperatur des Becherbodens
t	Time	Zeit
Dt	Period	Zeitraum
t_b	Service life (operating hours)	Brauchbarkeitsdauer (Betriebszeit)



Symbol	English	German
V	Voltage	Spannung
V_F	Forming voltage	Formierspannung
V_{op}	Operating voltage	Betriebsspannung
V_R	Rated voltage, DC voltage	Nennspannung, Gleichspannung
V_S	Surge voltage	Spitzenspannung
X_C	Capacitive reactance	Kapazitiver Blindwiderstand
X_L	Inductive reactance	Induktiver Blindwiderstand
Z	Impedance	Scheinwiderstand
Z_T	Impedance at temperature T	Scheinwiderstand bei Temperatur T
tan d	Dissipation factor	Verlustfaktor
l	Failure rate	Ausfallrate
ϵ_0	Absolute permittivity	Elektrische Feldkonstante
ϵ_r	Relative permittivity	Dielektrizitätszahl
w	Angular velocity; 2 p f	Kreisfrequenz; 2 p f

Note

All dimensions are given in mm.

The following applies to all products named in this publication:

1. Some parts of this publication contain statements about the suitability of our products for certain areas of application. These statements are based on our knowledge of typical requirements that are often placed on our products in the areas of application concerned. We nevertheless expressly point out that such statements cannot be regarded as binding statements about the suitability of our products for a particular customer application. As a rule, EPCOS is either unfamiliar with individual customer applications or less familiar with them than the customers themselves. For these reasons, it is always ultimately incumbent on the customer to check and decide whether an EPCOS product with the properties described in the product specification is suitable for use in a particular customer application.
2. We also point out that in individual cases, a malfunction of electronic components or failure before the end of their usual service life cannot be completely ruled out in the current state of the art, even if they are operated as specified. In customer applications requiring a very high level of operational safety and especially in customer applications in which the malfunction or failure of an electronic component could endanger human life or health (e.g. in accident prevention or lifesaving systems), it must therefore be ensured by means of suitable design of the customer application or other action taken by the customer (e.g. installation of protective circuitry or redundancy) that no injury or damage is sustained by third parties in the event of malfunction or failure of an electronic component.
3. The warnings, cautions and product-specific notes must be observed.
4. In order to satisfy certain technical requirements, some of the products described in this publication may contain substances subject to restrictions in certain jurisdictions (e.g. because they are classed as hazardous). Useful information on this will be found in our Material Data Sheets on the Internet (www.epcos.com/material). Should you have any more detailed questions, please contact our sales offices.
5. We constantly strive to improve our products. Consequently, the products described in this publication may change from time to time. The same is true of the corresponding product specifications. Please check therefore to what extent product descriptions and specifications contained in this publication are still applicable before or when you place an order. We also reserve the right to discontinue production and delivery of products. Consequently, we cannot guarantee that all products named in this publication will always be available. The aforementioned does not apply in the case of individual agreements deviating from the foregoing for customer-specific products.
6. Unless otherwise agreed in individual contracts, all orders are subject to the current version of the "General Terms of Delivery for Products and Services in the Electrical Industry" published by the German Electrical and Electronics Industry Association (ZVEI).
7. The trade names EPCOS, BAOKE, Alu-X, CeraDiode, CSMP, CSSP, CTVS, DeltaCap, DigiSiMic, DSSP, FormFit, MiniBlue, MiniCell, MKK, MKD, MLSC, MotorCap, PCC, PhaseCap, PhaseCube, PhaseMod, PhiCap, SIFERRIT, SIFI, SIKOREL, SilverCap, SIMDAD, SiMic, SIMID, SineFormer, SIOV, SIP5D, SIP5K, ThermoFuse, WindCap are trademarks registered or pending in Europe and in other countries. Further information will be found on the Internet at www.epcos.com/trademarks.