



## Aluminum electrolytic capacitors

### Snap-in capacitors

Series/Type: B43508

Date: December 2010

## Long-life grade capacitors

### Applications

- Frequency converters
- Professional power supplies in industrial electronics and in data processing equipment
- Switch-mode power supplies in entertainment electronics

### Features

- Extremely high CV product, ultra compact
- High reliability
- High ripple current capability
- Different case sizes available for each capacitance value
- Capacitors with all insulation versions pass the needle flame test according to IEC 60695-11-5 for all flame exposure times up to 120 s
- RoHS-compatible

### Construction

- Charge/discharge-proof, polar
- Aluminum case, fully insulated with PVC
- Version with PET insulation available
- Version with additional PET insulation cap on terminal side available for insulating the capacitor from the PCB
- Snap-in solder pins to hold component in place on PC-board
- Minus pole marking on case surface
- Minus pole not insulated from case
- Overload protection by safety vent on the base

### Terminals

- Standard version with 2 terminals,  
2 lengths available: 6.3 and 4.5 mm
- 3 terminals to ensure correct insertion: length 4.5 mm

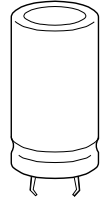

**Specifications and characteristics in brief**

Rated voltage $V_R$	200 ... 450 V DC											
Surge voltage $V_S$	1.15 $V_R$ (for $V_R$ £ 250 V DC) 1.10 $V_R$ (for $V_R$ <sup>3</sup> 400 V DC)											
Rated capacitance $C_R$	82 ... 2700 $\mu$ F											
Capacitance tolerance	±20% M											
Dissipation factor tan d (20 °C, 120 Hz)	$V_R$ £ 250 V DC: tan d £ 0.15 $V_R$ <sup>3</sup> 400 V DC: tan d £ 0.20											
Leakage current $I_{leak}$ (5 min, 20 °C)	$I_{leak} \leq 0.3 \mu A \cdot \left( \frac{C_R}{\mu F} \cdot \frac{V_R}{V} \right)^{0.7} + 4 \mu A$											
Self-inductance ESL	Approx. 20 nH											
Useful life 105 °C; $V_R$ ; $I_{AC,R}$ 85 °C; $V_R$ ; $I_{AC,max}$ 40 °C; $V_R$ ; 1.9 $I_{AC,R}$	> 3000 h > 6500 h > 200000 h	Requirements: DC/C £ ±30% of initial value tan d £ 3 times initial specified limit $I_{leak}$ £ initial specified limit										
Load life test 105 °C; $V_R$ ; $I_{AC,R}$	2000 h	Post test requirements DC/C £ ±20% of initial value tan d £ 2 times initial specified limit $I_{leak}$ £ initial specified limit										
Voltage endurance test 105 °C; $V_R$	2000 h	Post test requirements: DC/C £ ±10% of initial value tan d £ 1.3 times initial specified limit $I_{leak}$ £ initial specified limit										
Vibration resistance test	To IEC 60068-2-6, test Fc: Frequency range 10 Hz ... 55 Hz, displacement amplitude 0.35 mm, acceleration max. 5 g, duration 3 ´ 2 h. Capacitor mounted by its body which is rigidly clamped to the work surface.											
Characteristics at low temperature	Max. impedance ratio at 100 Hz	<table border="1"> <thead> <tr> <th><math>V_R</math></th> <th>£ 250 V</th> <th><sup>3</sup> 400 V</th> </tr> </thead> <tbody> <tr> <td><math>Z_{-25^\circ C} / Z_{20^\circ C}</math></td> <td>4</td> <td>7</td> </tr> <tr> <td><math>Z_{-40^\circ C} / Z_{20^\circ C}</math></td> <td>7</td> <td>13</td> </tr> </tbody> </table>	$V_R$	£ 250 V	<sup>3</sup> 400 V	$Z_{-25^\circ C} / Z_{20^\circ C}$	4	7	$Z_{-40^\circ C} / Z_{20^\circ C}$	7	13	
$V_R$	£ 250 V	<sup>3</sup> 400 V										
$Z_{-25^\circ C} / Z_{20^\circ C}$	4	7										
$Z_{-40^\circ C} / Z_{20^\circ C}$	7	13										
IEC climatic category	To IEC 60068-1: ■ $V_R$ £ 250 V DC: 40/105/56 ( 40 °C/+105 °C/56 days damp heat test) ■ $V_R$ <sup>3</sup> 400 V DC: 25/105/56 ( 25 °C/+105 °C/56 days damp heat test) The capacitors can be operated in the temperature range of 40 °C to +105 °C but the impedance at 40 °C should be taken into consideration.											
Detail specification	Similar to CECC 30301-809											
Sectional specification	IEC 60384-4											



B43508

Ultra compact 105 °C

### Dimensional drawings

Snap-in capacitors with standard insulation (PVC or PET)

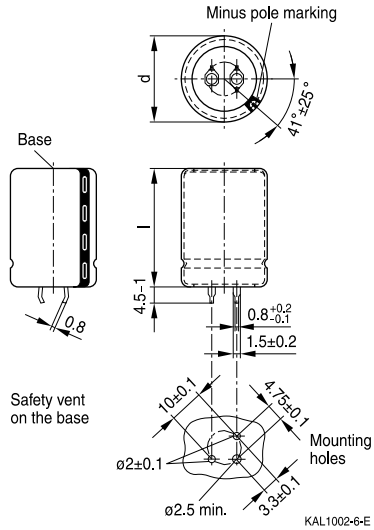
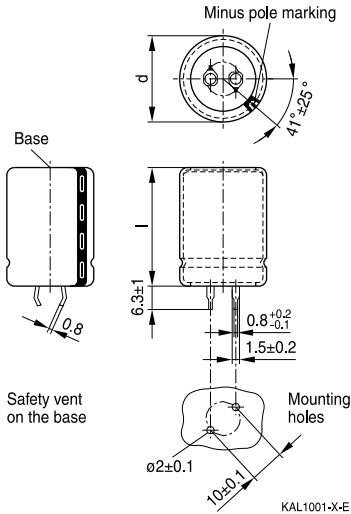

Snap-in terminals, length (6.3 ± 1) mm.  
Also available in a shorter version with a length of (4.5 ± 1) mm. PET insulation is marked with label "PET" on the sleeve.

Snap-in capacitors are also available with 3 terminals (length (4.5 ± 1) mm). PET insulation is marked with label "PET" on the sleeve.

Dimensions (mm)	Approx. weight (g)	Packing units (pcs.)
d +1	l ±2	
22	25	9
22	30	12
22	35	15
22	40	18
22	45	20
22	50	24
25	25	13
25	30	17
25	35	19
25	40	22
25	45	25
25	50	29
25	55	32

Dimensions (mm)	Approx. weight (g)	Packing units (pcs.)
d +1	l ±2	
30	25	17
30	30	23
30	35	29
30	40	36
30	45	41
30	50	46
30	55	53
35	25	22
35	30	29
35	35	36
35	40	41
35	45	56
35	50	70
35	55	81



Snap-in capacitors with PVC insulation and PET insulation cap on terminal side

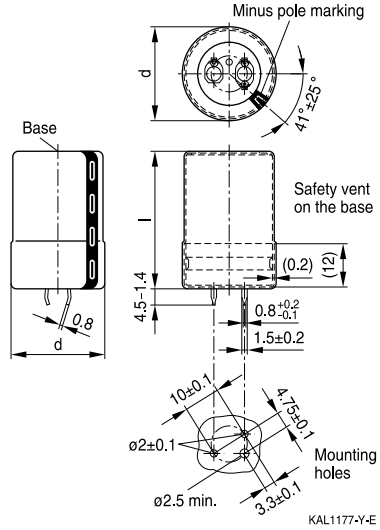
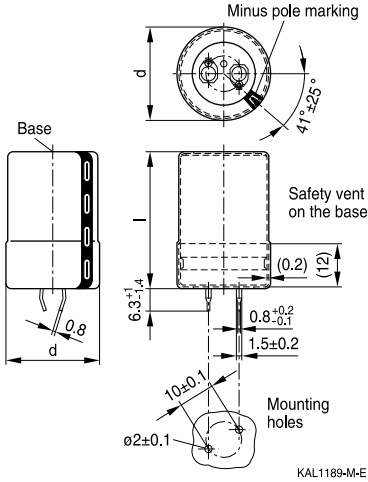

Snap-in terminals, length (6.3 +1/ 1.4) mm. Also available in a shorter version with a length of (4.5 1.4) mm. PET insulation cap is positioned under the insulation sleeve.

Snap-in capacitors are also available with 3 terminals (length (4.5 1.4) mm). PET insulation cap is positioned under the insulation sleeve.

Dimensions (mm)		Approx. weight (g)	Packing units (pcs.)
d +1.4	l +2.2/ 2		
22	25	9	160
22	30	12	160
22	35	15	160
22	40	18	160
22	45	20	160
22	50	24	160
25	25	13	130
25	30	17	130
25	35	19	130
25	40	22	130
25	45	25	130
25	50	29	130
25	55	32	130

Dimensions (mm)		Approx. weight (g)	Packing units (pcs.)
d +1.4	l +2.2/ 2		
30	25	17	80
30	30	23	80
30	35	29	80
30	40	36	80
30	45	41	80
30	50	46	80
30	55	53	80
35	25	22	60
35	30	29	60
35	35	36	60
35	40	41	60
35	45	56	60
35	50	70	60
35	55	81	60

**B43508**
**Ultra compact 105 °C**
**Packing of snap-in capacitors**

For ecological reasons the packing is pure cardboard. Components can be withdrawn (in full or in part) in the correct position for insertion.

**Ordering codes for terminal styles and insulation features**
**Identification in 3rd block of ordering code**
**Snap-in capacitors**

Terminal version	Insulation version		
	PVC	PET	PVC plus PET cap
Standard terminals 6.3 mm	M000	M060	M080
Short terminals 4.5 mm	M007	M067	M087
3 terminals 4.5 mm	M002	M062	M082

**Ordering examples:**

- B43508A5107M007 } snap-in capacitor with short terminals and standard PVC insulation
- B43508A5107M062 } snap-in capacitor with 3 terminals and PET insulation
- B43508A5107M080 } snap-in capacitor with standard terminals and PVC insulation with additional PET insulation cap on terminal side



## Overview of available types

$V_R$ (V DC)	200	250	400	450
	Case dimensions d ´ l (mm)			
$C_R$ (nF)				
82				22 ´ 25
100			22 ´ 25	22 ´ 30 25 ´ 25
120			22 ´ 30	22 ´ 35 25 ´ 30
150			22 ´ 30 25 ´ 25	22 ´ 40 25 ´ 30 30 ´ 25
180			22 ´ 35 25 ´ 30	22 ´ 45 25 ´ 35 30 ´ 30
220		22 ´ 25	22 ´ 40 25 ´ 35 30 ´ 25	22 ´ 50 25 ´ 40 30 ´ 30 35 ´ 25
270		22 ´ 30	22 ´ 50 25 ´ 40 30 ´ 30	25 ´ 50 30 ´ 35 35 ´ 30
330	22 ´ 25	22 ´ 30 25 ´ 25	25 ´ 45 30 ´ 35 35 ´ 25	25 ´ 55 30 ´ 40 35 ´ 35
390	22 ´ 30 25 ´ 25	22 ´ 35 25 ´ 30	25 ´ 50 30 ´ 35 35 ´ 30	30 ´ 45 35 ´ 35
470	22 ´ 35 25 ´ 30	22 ´ 40 25 ´ 30 30 ´ 25	30 ´ 40 35 ´ 35	30 ´ 55 35 ´ 40
560	22 ´ 35 25 ´ 30	22 ´ 45 25 ´ 35 30 ´ 30	30 ´ 50 35 ´ 40	35 ´ 45
680	22 ´ 40 25 ´ 35 30 ´ 25	22 ´ 50 25 ´ 40 30 ´ 30 35 ´ 25	30 ´ 55 35 ´ 45	35 ´ 55

**B43508**
**Ultra compact 105 °C**

$V_R$ (V DC)	200	250	400	450
	Case dimensions d ´ l (mm)			
$C_R$ (nF)				
820	22 ´ 50 25 ´ 40 30 ´ 30 35 ´ 25	25 ´ 45 30 ´ 35 35 ´ 30	35 ´ 50	
1000	25 ´ 45 30 ´ 35 35 ´ 30	25 ´ 55 30 ´ 40 35 ´ 30	35 ´ 55	
1200	25 ´ 50 30 ´ 40 35 ´ 30	30 ´ 45 35 ´ 35		
1500	30 ´ 45 35 ´ 35	30 ´ 55 35 ´ 40		
1800	30 ´ 50 35 ´ 40	35 ´ 50		
2200	35 ´ 45	35 ´ 55		
2700	35 ´ 55			

The capacitance and voltage ratings listed above are available in different cases upon request. Other voltage and capacitance ratings are also available upon request.



**Technical data and ordering codes**

$C_R$ 100 Hz 20 °C nF	Case dimensions d × l mm	$ESR_{typ}$ 100 Hz 20 °C mW	$Z_{max}$ 10 kHz 20 °C mW	$I_{AC,max}$ 100 Hz 60 °C A	$I_{AC,max}$ 100 Hz 85 °C A	$I_{AC,R}^{(1)}$ 100 Hz 105 °C A	Ordering code (composition see below)
<b><math>V_R = 200</math> V DC</b>							
330	22 × 25	350	480	2.85	2.13	1.05	B43508A2337M0*#
390	22 × 30	300	400	3.23	2.42	1.19	B43508A2397M0*#
390	25 × 25	300	400	3.19	2.39	1.18	B43508B2397M0*#
470	22 × 35	250	340	3.68	2.75	1.36	B43508A2477M0*#
470	25 × 30	250	340	3.65	2.73	1.35	B43508B2477M0*#
560	22 × 35	210	280	4.02	3.00	1.48	B43508A2567M0*#
560	25 × 30	210	280	3.99	2.98	1.47	B43508B2567M0*#
680	22 × 40	170	230	4.56	3.41	1.69	B43508A2687M0*#
680	25 × 35	170	230	4.55	3.40	1.68	B43508B2687M0*#
680	30 × 25	170	230	4.02	3.00	1.48	B43508C2687M0*#
820	22 × 50	140	200	5.28	3.95	1.95	B43508A2827M0*#
820	25 × 40	140	200	5.16	3.86	1.91	B43508B2827M0*#
820	30 × 30	140	200	4.60	3.44	1.70	B43508C2827M0*#
820	35 × 25	140	200	3.91	2.92	1.44	B43508D2827M0*#
1000	25 × 45	120	160	5.85	4.38	2.16	B43508A2108M0*#
1000	30 × 35	120	160	5.26	3.93	1.95	B43508B2108M0*#
1000	35 × 30	120	160	4.79	3.58	1.77	B43508C2108M0*#
1200	25 × 50	100	130	6.57	4.92	2.43	B43508A2128M0*#
1200	30 × 40	100	130	6.33	4.74	2.34	B43508B2128M0*#
1200	35 × 30	100	130	5.24	3.92	1.94	B43508C2128M0*#
1500	30 × 45	75	110	7.28	5.44	2.69	B43508A2158M0*#
1500	35 × 35	75	110	6.07	4.54	2.25	B43508B2158M0*#
1800	30 × 50	65	90	8.18	6.12	3.02	B43508A2188M0*#
1800	35 × 40	65	90	6.86	5.13	2.54	B43508B2188M0*#
2200	35 × 45	55	75	7.80	5.84	2.89	B43508A2228M0*#
2700	35 × 55	45	60	9.07	6.78	3.36	B43508A2278M0*#

**Composition of ordering code**
**\* = Insulation feature**

0 = PVC insulation

6 = PET insulation

 8 = PVC insulation with additional PET insulation  
cap on terminal side

**# = Terminal style**

0 = snap-in standard terminals (6.3 mm)

2 = snap-in 3 terminals (4.5 mm)

7 = snap-in short terminals (4.5 mm)

 1) 120-Hz conversion factor of ripple current:  $I_{AC}(120\text{ Hz}) = 1.03 \cdot I_{AC}(100\text{ Hz})$



B43508

Ultra compact 105 °C

Technical data and ordering codes

$C_R$	Case dimensions	$ESR_{typ}$	$Z_{max}$	$I_{AC,max}$	$I_{AC,max}$	$I_{AC,R^2}$	Ordering code
100 Hz	d ´ l	100 Hz	10 kHz	100 Hz	100 Hz	100 Hz	(composition see below)
20 °C	mm	20 °C	20 °C	60 °C	85 °C	105 °C	
nF		mW	mW	A	A	A	
$V_R = 250 V DC$							
220	22 ´ 25	530	710	2.48	1.85	0.91	B43508E2227M0*#
270	22 ´ 30	430	580	2.86	2.14	1.06	B43508E2277M0*#
330	22 ´ 30	350	480	3.16	2.37	1.17	B43508E2337M0*#
330	25 ´ 25	350	480	3.11	2.32	1.15	B43508F2337M0*#
390	22 ´ 35	300	400	3.56	2.66	1.32	B43508E2397M0*#
390	25 ´ 30	300	400	3.52	2.63	1.30	B43508F2397M0*#
470	22 ´ 40	250	340	4.03	3.02	1.49	B43508E2477M0*#
470	25 ´ 30	250	340	3.86	2.89	1.43	B43508F2477M0*#
470	30 ´ 25	250	340	3.48	2.60	1.29	B43508G2477M0*#
560	22 ´ 45	210	280	4.52	3.38	1.67	B43508E2567M0*#
560	25 ´ 35	210	280	4.37	3.27	1.62	B43508F2567M0*#
560	30 ´ 30	210	280	3.96	2.96	1.46	B43508G2567M0*#
680	22 ´ 50	170	230	5.11	3.82	1.89	B43508E2687M0*#
680	25 ´ 40	170	230	4.97	3.72	1.84	B43508F2687M0*#
680	30 ´ 30	170	230	4.37	3.27	1.61	B43508G2687M0*#
680	35 ´ 25	170	230	3.66	2.74	1.35	B43508H2687M0*#
820	25 ´ 45	140	200	5.61	4.20	2.07	B43508E2827M0*#
820	30 ´ 35	140	200	4.97	3.72	1.84	B43508F2827M0*#
820	35 ´ 30	140	200	4.46	3.33	1.65	B43508G2827M0*#
1000	25 ´ 55	120	160	6.49	4.86	2.40	B43508E2108M0*#
1000	30 ´ 40	120	160	6.03	4.51	2.23	B43508F2108M0*#
1000	35 ´ 30	120	160	4.92	3.68	1.82	B43508G2108M0*#
1200	30 ´ 45	100	130	6.79	5.08	2.51	B43508E2128M0*#
1200	35 ´ 35	100	130	5.59	4.18	2.07	B43508F2128M0*#
1500	30 ´ 55	75	110	7.96	5.96	2.95	B43508E2158M0*#
1500	35 ´ 40	75	110	6.44	4.82	2.38	B43508F2158M0*#
1800	35 ´ 50	65	90	7.44	5.57	2.75	B43508E2188M0*#
2200	35 ´ 55	55	75	8.42	6.30	3.12	B43508E2228M0*#

Composition of ordering code

\* = Insulation feature

0 = PVC insulation

6 = PET insulation

8 = PVC insulation with additional PET insulation cap on terminal side

# = Terminal style

0 = snap-in standard terminals (6.3 mm)

2 = snap-in 3 terminals (4.5 mm)

7 = snap-in short terminals (4.5 mm)

2) 120-Hz conversion factor of ripple current:  $I_{AC}(120 Hz) = 1.03 I_{AC}(100 Hz)$

**Technical data and ordering codes**

$C_R$ 100 Hz 20 °C nF	Case dimensions d × l mm	$ESR_{typ}$ 100 Hz 20 °C mW	$Z_{max}$ 10 kHz 20 °C mW	$I_{AC,max}$ 100 Hz 60 °C A	$I_{AC,max}$ 100 Hz 85 °C A	$I_{AC,R}^{(3)}$ 100 Hz 105 °C A	Ordering code (composition see below)
<b><math>V_R = 400</math> V DC</b>							
100	22 × 25	1230	1730	1.63	1.22	0.60	B43508A9107M0*#
120	22 × 30	1020	1440	1.87	1.39	0.69	B43508A9127M0*#
150	22 × 30	820	1150	2.09	1.56	0.77	B43508A9157M0*#
150	25 × 25	820	1150	2.09	1.56	0.77	B43508B9157M0*#
180	22 × 35	680	960	2.37	1.77	0.87	B43508A9187M0*#
180	25 × 30	680	960	2.39	1.79	0.88	B43508B9187M0*#
220	22 × 40	560	790	2.70	2.02	1.00	B43508A9227M0*#
220	25 × 35	560	790	2.74	2.05	1.01	B43508B9227M0*#
220	30 × 25	560	790	2.65	1.98	0.98	B43508C9227M0*#
270	22 × 50	460	640	3.15	2.35	1.16	B43508A9277M0*#
270	25 × 40	460	640	3.13	2.34	1.16	B43508B9277M0*#
270	30 × 30	460	640	3.06	2.29	1.13	B43508C9277M0*#
330	25 × 45	370	530	3.56	2.66	1.31	B43508A9337M0*#
330	30 × 35	370	530	3.50	2.62	1.29	B43508B9337M0*#
330	35 × 25	370	530	3.20	2.39	1.18	B43508C9337M0*#
390	25 × 50	320	450	3.96	2.96	1.46	B43508A9397M0*#
390	30 × 35	320	450	3.81	2.85	1.41	B43508B9397M0*#
390	35 × 30	320	450	3.86	2.88	1.43	B43508C9397M0*#
470	30 × 40	260	370	4.59	3.44	1.70	B43508A9477M0*#
470	35 × 35	260	370	4.39	3.28	1.62	B43508B9477M0*#
560	30 × 50	220	310	5.29	3.95	1.96	B43508A9567M0*#
560	35 × 40	220	310	4.94	3.70	1.83	B43508B9567M0*#
680	30 × 55	180	260	5.96	4.46	2.20	B43508A9687M0*#
680	35 × 45	180	260	5.60	4.19	2.07	B43508B9687M0*#
820	35 × 50	150	210	6.31	4.72	2.33	B43508A9827M0*#
1000	35 × 55	120	180	7.13	5.33	2.64	B43508A9108M0*#

**Composition of ordering code**
**\* = Insulation feature**

0 = PVC insulation

6 = PET insulation

 8 = PVC insulation with additional PET insulation  
cap on terminal side

**# = Terminal style**

0 = snap-in standard terminals (6.3 mm)

2 = snap-in 3 terminals (4.5 mm)

7 = snap-in short terminals (4.5 mm)

 3) 120-Hz conversion factor of ripple current:  $I_{AC}(120\text{ Hz}) = 1.03 \cdot I_{AC}(100\text{ Hz})$

**B43508**
**Ultra compact 105 °C**
**Technical data and ordering codes**

$C_R$	Case dimensions	$ESR_{typ}$ 100 Hz 20 °C nF	$Z_{max}$ 10 kHz 20 °C mW	$I_{AC,max}$ 100 Hz 60 °C A	$I_{AC,max}$ 100 Hz 85 °C A	$I_{AC,R}^{(4)}$ 100 Hz 105 °C A	Ordering code (composition see below)
<b><math>V_R = 450</math> V DC</b>							
82	22 ´ 25	1500	2100	1.58	1.18	0.58	B43508A5826M0*#
100	22 ´ 30	1230	1730	1.82	1.36	0.67	B43508A5107M0*#
100	25 ´ 25	1230	1730	1.82	1.36	0.67	B43508B5107M0*#
120	22 ´ 35	1020	1440	2.07	1.54	0.76	B43508A5127M0*#
120	25 ´ 30	1020	1440	2.08	1.55	0.77	B43508B5127M0*#
150	22 ´ 40	820	1150	2.38	1.78	0.88	B43508A5157M0*#
150	25 ´ 30	820	1150	2.33	1.74	0.86	B43508B5157M0*#
150	30 ´ 25	820	1150	2.39	1.79	0.88	B43508C5157M0*#
180	22 ´ 45	680	960	2.68	2.01	0.99	B43508A5187M0*#
180	25 ´ 35	680	960	2.64	1.97	0.97	B43508B5187M0*#
180	30 ´ 30	680	960	2.73	2.04	1.01	B43508C5187M0*#
220	22 ´ 50	560	790	3.04	2.27	1.12	B43508A5227M0*#
220	25 ´ 40	560	790	3.01	2.25	1.11	B43508B5227M0*#
220	30 ´ 30	560	790	3.02	2.26	1.11	B43508C5227M0*#
220	35 ´ 25	560	790	2.89	2.16	1.07	B43508D5227M0*#
270	25 ´ 50	460	640	3.51	2.63	1.30	B43508A5277M0*#
270	30 ´ 35	460	640	3.47	2.59	1.28	B43508B5277M0*#
270	35 ´ 30	460	640	3.55	2.65	1.31	B43508C5277M0*#
330	25 ´ 55	370	530	3.97	2.97	1.47	B43508A5337M0*#
330	30 ´ 40	370	530	4.21	3.15	1.56	B43508B5337M0*#
330	35 ´ 35	370	530	4.06	3.04	1.50	B43508C5337M0*#
390	30 ´ 45	320	450	4.71	3.52	1.74	B43508A5397M0*#
390	35 ´ 35	320	450	4.42	3.30	1.63	B43508B5397M0*#
470	30 ´ 55	260	370	5.42	4.05	2.00	B43508A5477M0*#
470	35 ´ 40	260	370	5.00	3.74	1.85	B43508B5477M0*#
560	35 ´ 45	220	310	5.62	4.20	2.08	B43508A5567M0*#
680	35 ´ 55	180	260	6.50	4.86	2.40	B43508A5687M0*#

**Composition of ordering code**

\* = Insulation feature

0 = PVC insulation

6 = PET insulation

8 = PVC insulation with additional PET insulation cap on terminal side

# = Terminal style

0 = snap-in standard terminals (6.3 mm)

2 = snap-in 3 terminals (4.5 mm)

7 = snap-in short terminals (4.5 mm)

4) 120-Hz conversion factor of ripple current:  $I_{AC}(120\text{ Hz}) = 1.03 \cdot I_{AC}(100\text{ Hz})$



**Useful life**

depending on ambient temperature  $T_A$  under ripple current operating conditions<sup>1)</sup>

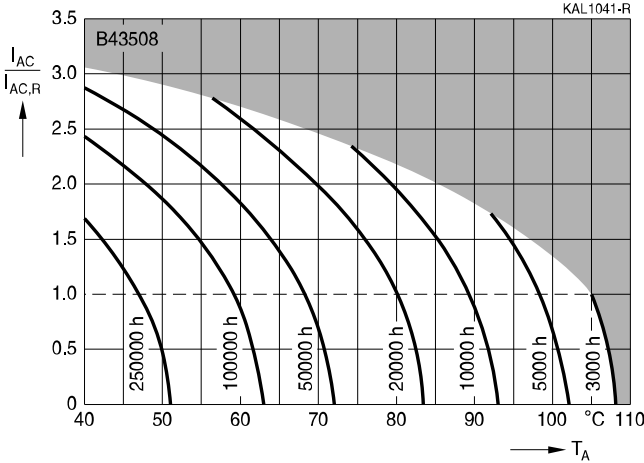

**Frequency factor of permissible ripple current  $I_{AC}$  versus frequency  $f$**

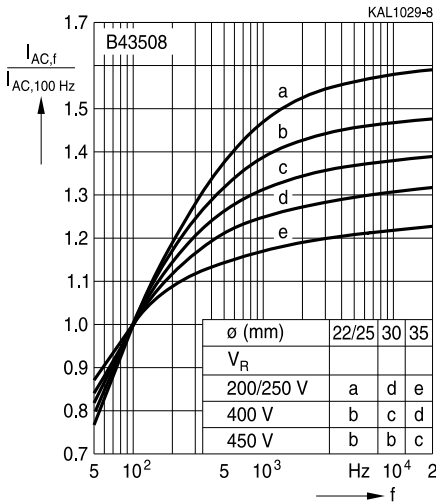

**Frequency characteristics of ESR  
Typical behavior**

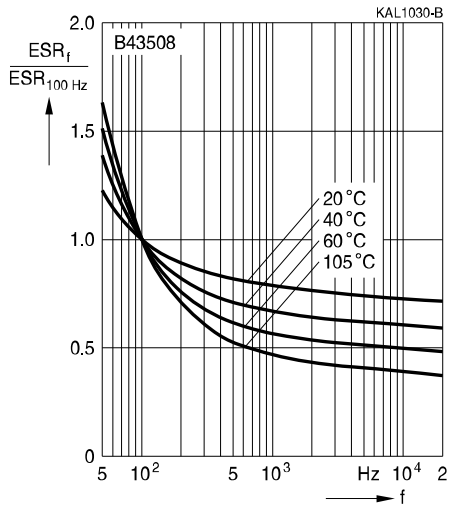

1) Refer to chapter "General technical information, 5.3 Calculation of useful life" for an explanation on how to interpret the useful life graphs.



B43508

Ultra compact 105 °C

Impedance Z versus frequency f  
 Typical behavior at 20 °C

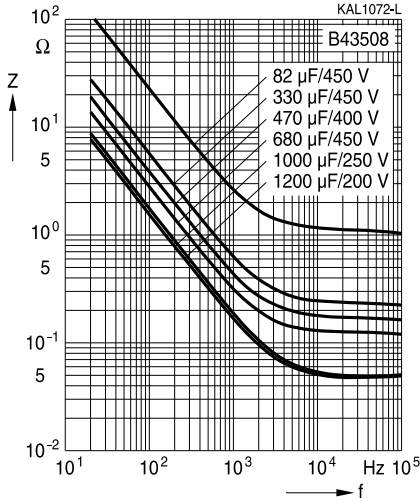



## Cautions and warnings

### Personal safety

The electrolytes used by EPCOS have not only been optimized with a view to the intended application, but also with regard to health and environmental compatibility. They do not contain any solvents that are detrimental to health, e.g. dimethyl formamide (DMF) or dimethyl acetamide (DMAC).

Furthermore, part of the high-voltage electrolytes used by EPCOS are self-extinguishing. They contain flame-retarding substances which will quickly extinguish any flame that may have been ignited.

As far as possible, EPCOS does not use any dangerous chemicals or compounds to produce operating electrolytes. However, in exceptional cases, such materials must be used in order to achieve specific physical and electrical properties because no safe substitute materials are currently known. However, the amount of dangerous materials used in our products has been limited to an absolute minimum. Nevertheless, the following rules should be observed when handling aluminum electrolytic capacitors:

- Any escaping electrolyte should not come into contact with eyes or skin.
- If electrolyte does come into contact with the skin, wash the affected parts immediately with running water. If the eyes are affected, rinse them for 10 minutes with plenty of water. If symptoms persist, seek medical treatment.
- Avoid breathing in electrolyte vapor or mists. Workplaces and other affected areas should be well ventilated. Clothing that has been contaminated by electrolyte must be changed and rinsed in water.



Product safety

The table below summarizes the safety instructions that must be observed without fail. A detailed description can be found in the relevant sections of chapter "General technical information".

Topic	Safety information	Reference chapter "General technical information"
Polarity	Make sure that polar capacitors are connected with the right polarity.	1 "Basic construction of aluminum electrolytic capacitors"
Reverse voltage	Voltages polarity classes should be prevented by connecting a diode.	3.1.6 "Reverse voltage"
Upper category temperature	Do not exceed the upper category temperature.	7.2 "Maximum permissible operating temperature"
Maintenance	Make periodic inspections of the capacitors. Before the inspection, make sure that the power supply is turned off and carefully discharge the electricity of the capacitors. Do not apply any mechanical stress to the capacitor terminals.	10 "Maintenance"
Mounting position of screw-terminal capacitors	Do not mount the capacitor with the terminals (safety vent) upside down.	11.1. "Mounting positions of capacitors with screw terminals"
Mounting of single-ended capacitors	The internal structure of single-ended capacitors might be damaged if excessive force is applied to the lead wires. Avoid any compressive, tensile or flexural stress. Do not move the capacitor after soldering to PC board. Do not pick up the PC board by the soldered capacitor. Do not insert the capacitor on the PC board with a hole space different to the lead space specified.	11.4 "Mounting considerations for single-ended capacitors"
Robustness of terminals	The following maximum tightening torques must not be exceeded when connecting screw terminals: M5: 2 Nm M6: 2.5 Nm	11.3 "Mounting torques"
Soldering	Do not exceed the specified time or temperature limits during soldering.	11.5 "Soldering"





Topic	Safety information	Reference chapter "General technical information"
Soldering, cleaning agents	Do not allow halogenated hydrocarbons to come into contact with aluminum electrolytic capacitors.	11.6 "Cleaning agents"
Passive flammability	Avoid external energy, such as fire or electricity.	8.1 "Passive flammability"
Active flammability	Avoid overload of the capacitors.	8.2 "Active flammability"
		Reference chapter "Capacitors with screw terminals"
Breakdown strength of insulating sleeves	Do not damage the insulating sleeve, especially when ring clips are used for mounting.	"Screw terminals accessories"

**B43508**
**Ultra compact 105 °C**
**Symbols and terms**

Symbol	English	German
C	Capacitance	Kapazität
$C_R$	Rated capacitance	Nennkapazität
$C_S$	Series capacitance	Serienkapazität
$C_{S,T}$	Series capacitance at temperature T	Serienkapazität bei Temperatur T
$C_f$	Capacitance at frequency f	Kapazität bei Frequenz f
d	Case diameter, nominal dimension	Gehäusedurchmesser, Nennmaß
$d_{max}$	Maximum case diameter	Maximaler Gehäusedurchmesser
ESL	Self-inductance	Eigeninduktivität
ESR	Equivalent series resistance	Ersatzserienwiderstand
$ESR_f$	Equivalent series resistance at frequency f	Ersatzserienwiderstand bei Frequenz f
$ESR_T$	Equivalent series resistance at temperature T	Ersatzserienwiderstand bei Temperatur T
f	Frequency	Frequenz
I	Current	Strom
$I_{AC}$	Alternating current (ripple current)	Wechselstrom
$I_{AC,rms}$	Root-mean-square value of alternating current	Wechselstrom, Effektivwert
$I_{AC,f}$	Ripple current at frequency f	Wechselstrom bei Frequenz f
$I_{AC,max}$	Maximum permissible ripple current	Maximal zulässiger Wechselstrom
$I_{AC,R}$	Rated ripple current	Nennwechselstrom
$I_{AC,R} (B)$	Rated ripple current for base cooling	Nennwechselstromstrom für Bodenkühlung
$I_{leak}$	Leakage current	Reststrom
$I_{leak,op}$	Operating leakage current	Betriebsreststrom
l	Case length, nominal dimension	Gehäuselänge, Nennmaß
$l_{max}$	Maximum case length (without terminals and mounting stud)	Maximale Gehäuselänge (ohne Anschlüsse und Gewindebolzen)
R	Resistance	Widerstand
$R_{ins}$	Insulation resistance	Isolationswiderstand
$R_{symm}$	Balancing resistance	Symmetrierwiderstand
T	Temperature	Temperatur
DT	Temperature difference	Temperaturdifferenz
$T_A$	Ambient temperature	Umgebungstemperatur
$T_C$	Case temperature	Gehäusetemperatur
$T_B$	Capacitor base temperature	Temperatur des Becherbodens
t	Time	Zeit
Dt	Period	Zeitraum
$t_b$	Service life (operating hours)	Brauchbarkeitsdauer (Betriebszeit)



Symbol	English	German
V	Voltage	Spannung
V <sub>F</sub>	Forming voltage	Formierspannung
V <sub>op</sub>	Operating voltage	Betriebsspannung
V <sub>R</sub>	Rated voltage, DC voltage	Nennspannung, Gleichspannung
V <sub>S</sub>	Surge voltage	Spitzenspannung
X <sub>C</sub>	Capacitive reactance	Kapazitiver Blindwiderstand
X <sub>L</sub>	Inductive reactance	Induktiver Blindwiderstand
Z	Impedance	Scheinwiderstand
Z <sub>T</sub>	Impedance at temperature T	Scheinwiderstand bei Temperatur T
tan d	Dissipation factor	Verlustfaktor
l	Failure rate	Ausfallrate
ε <sub>0</sub>	Absolute permittivity	Elektrische Feldkonstante
ε <sub>r</sub>	Relative permittivity	Dielektrizitätszahl
w	Angular velocity; 2 π f	Kreisfrequenz; 2 π f

**Note**

All dimensions are given in mm.

The following applies to all products named in this publication:

1. Some parts of this publication contain statements about the suitability of our products for certain areas of application. These statements are based on our knowledge of typical requirements that are often placed on our products in the areas of application concerned. We nevertheless expressly point out that such statements cannot be regarded as binding statements about the suitability of our products for a particular customer application. As a rule, EPCOS is either unfamiliar with individual customer applications or less familiar with them than the customers themselves. For these reasons, it is always ultimately incumbent on the customer to check and decide whether an EPCOS product with the properties described in the product specification is suitable for use in a particular customer application.
2. We also point out that in individual cases, a malfunction of electronic components or failure before the end of their usual service life cannot be completely ruled out in the current state of the art, even if they are operated as specified. In customer applications requiring a very high level of operational safety and especially in customer applications in which the malfunction or failure of an electronic component could endanger human life or health (e.g. in accident prevention or lifesaving systems), it must therefore be ensured by means of suitable design of the customer application or other action taken by the customer (e.g. installation of protective circuitry or redundancy) that no injury or damage is sustained by third parties in the event of malfunction or failure of an electronic component.
3. The warnings, cautions and product-specific notes must be observed.
4. In order to satisfy certain technical requirements, some of the products described in this publication may contain substances subject to restrictions in certain jurisdictions (e.g. because they are classed as hazardous). Useful information on this will be found in our Material Data Sheets on the Internet ([www.epcos.com/material](http://www.epcos.com/material)). Should you have any more detailed questions, please contact our sales offices.
5. We constantly strive to improve our products. Consequently, the products described in this publication may change from time to time. The same is true of the corresponding product specifications. Please check therefore to what extent product descriptions and specifications contained in this publication are still applicable before or when you place an order. We also reserve the right to discontinue production and delivery of products. Consequently, we cannot guarantee that all products named in this publication will always be available. The aforementioned does not apply in the case of individual agreements deviating from the foregoing for customer-specific products.
6. Unless otherwise agreed in individual contracts, all orders are subject to the current version of the "General Terms of Delivery for Products and Services in the Electrical Industry" published by the German Electrical and Electronics Industry Association (ZVEI).
7. The trade names EPCOS, BAOKE, Alu-X, CeraDiode, CSMP, CSSP, CTVS, DeltaCap, DigiSiMic, DSSP, FormFit, MiniBlue, MiniCell, MKK, MKD, MLSC, MotorCap, PCC, PhaseCap, PhaseCube, PhaseMod, PhiCap, SIFERRIT, SIFI, SIKOREL, SilverCap, SIMDAD, SiMic, SIMID, SineFormer, SIOV, SIP5D, SIP5K, ThermoFuse, WindCap are trademarks registered or pending in Europe and in other countries. Further information will be found on the Internet at [www.epcos.com/trademarks](http://www.epcos.com/trademarks).