



Ferrites and accessories

EPX 9/9
Core and accessories

Series/Type: **B65857C, B65852**
Date: September 2006

- For xDSL line transformers
- Height of EP13
- Optimized design for low distortion
- Delivery mode: sets

Magnetic characteristics (per set)

$$\Sigma l/A = 1.09 \text{ mm}^{-1}$$

$$l_e = 19.0 \text{ mm}$$

$$A_e = 17.5 \text{ mm}^2$$

$$A_{\text{min}} = 13.9 \text{ mm}^2$$

$$V_e = 333 \text{ mm}^3$$

Approx. weight 3 g/set

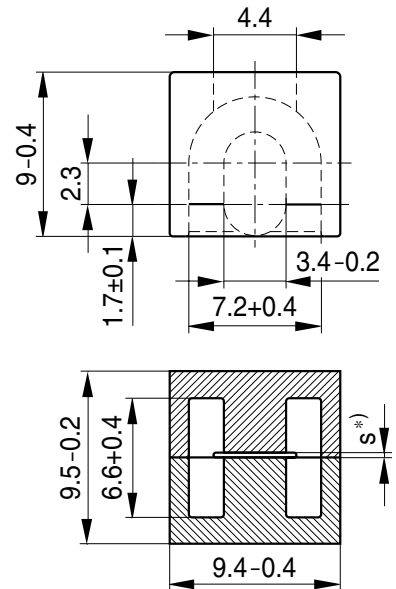

*) gapped (one-sided)

FEP0055-Z-E

Gapped

Material	A _L value nH	s approx. mm	μ _e	Ordering code
T38	63 ±3%	0.35	54	B65857C0063A038
	100 ±3%	0.22	86	B65857C0100A038
	160 ±4%	0.14	138	B65857C0160B038
	200 ±4%	0.11	173	B65857C0200B038
	250 ±5%	0.09	216	B65857C0250J038
	315 ±6%	0.07	272	B65857C0315C038
	400 ±7%	0.05	346	B65857C0400E038
T57	63 ±3%	0.34	54	B65857C0063A057
	100 ±3%	0.22	86	B65857C0100A057
	160 ±4%	0.13	138	B65857C0160B057
	200 ±4%	0.11	173	B65857C0200B057
	250 ±5%	0.08	216	B65857C0250J057
	315 ±6%	0.07	272	B65857C0315C057
	400 ±7%	0.05	346	B65857C0400E057
T66	63 ±3%	0.35	54	B65857C0063A066
	100 ±3%	0.22	86	B65857C0100A066
	160 ±4%	0.14	138	B65857C0160B066
	200 ±4%	0.11	173	B65857C0200B066
	250 ±5%	0.09	216	B65857C0250J066
	315 ±6%	0.07	272	B65857C0315C066
	400 ±7%	0.05	346	B65857C0400E066

Gapped

Material	A _L value nH	s approx. mm	μ _e	Ordering code
N45	63 ±3%	0.34	54	B65857C0063A045
	100 ±3%	0.21	86	B65857C0100A045
	160 ±4%	0.13	138	B65857C0160B045
	200 ±4%	0.10	173	B65857C0200B045
	250 ±5%	0.08	216	B65857C0250J045
	315 ±6%	0.06	272	B65857C0315C045
	400 ±7%	0.05	346	B65857C0400E045

Ungapped

Material	A _L value nH	μ _e	Ordering code
N45	2400 +30/-20%	2070	B65857C0000R045
T57	2400 +30/-20%	2070	B65857C0000R057
T38	8000 +40/-30%	6910	B65857C0000Y038
T66	8100 +40/-30%	7000	B65857C0000Y066

SMD

SMD coil former with gullwing terminals

Material: GFR thermosetting plastic (UL 94 V-0, insulation class to IEC 60085: H \geq max. operating temperature 180 °C), color code black, CTI = 600 V
 DAP RX-1366 FR, [E123472 (M)], SUMITOMO BAKELITE NORTH AMERICA INC

Solderability: to IEC 60068-2-58, test Td, method 6 (Group 3): 245 °C, 3 s

Resistance to soldering heat: to IEC 60068-2-58, test Td, method 6 (Group 3): 255 °C, 10 s
 permissible soldering temperature for wire-wrap connection on coil former: 400 °C, 1 s

Winding: see Data Book 2007, chapter "Processing notes, 2.1"

Sections	A _N mm ²	l _N mm	A _R value μΩ	Terminals	Ordering code
1	6.6	18.1	94.0	8	B65852A1008D001

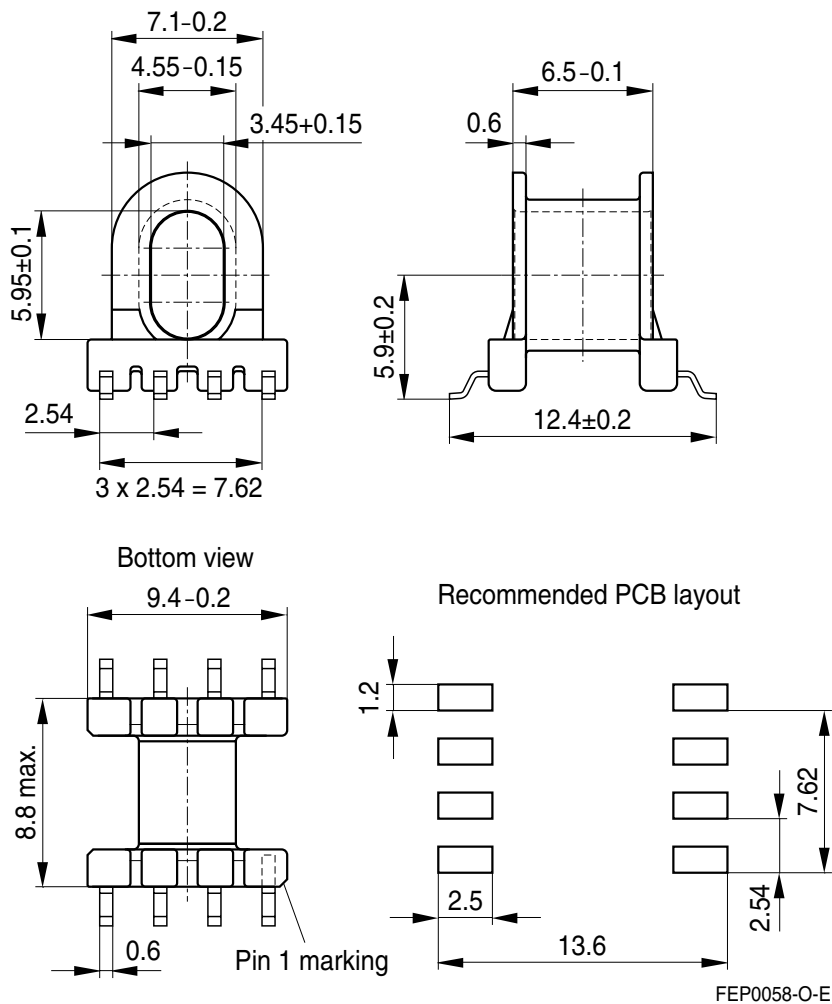

Mechanical stress and mounting

Ferrite cores have to meet mechanical requirements during assembling and for a growing number of applications. Since ferrites are ceramic materials one has to be aware of the special behavior under mechanical load.

As valid for any ceramic material, ferrite cores are brittle and sensitive to any shock, fast changing or tensile load. Especially high cooling rates under ultrasonic cleaning and high static or cyclic loads can cause cracks or failure of the ferrite cores.

For detailed information see Data Book 2007, chapter “General – Definitions, 8.1”.

Effects of core combination on A_L value

Stresses in the core affect not only the mechanical but also the magnetic properties. It is apparent that the initial permeability is dependent on the stress state of the core. The higher the stresses are in the core, the lower is the value for the initial permeability. Thus the embedding medium should have the greatest possible elasticity.

For detailed information see Data Book 2007, chapter “General – Definitions, 8.2”.

Heating up

Ferrites can run hot during operation at higher flux densities and higher frequencies.

NiZn-materials

The magnetic properties of NiZn-materials can change irreversible in high magnetic fields.

Processing notes

- The start of the winding process should be soft. Else the flanges may be destroyed.
- To strong winding forces may blast the flanges or squeeze the tube that the cores can no more be mount.
- To long soldering time at high temperature (>300 °C) may effect coplanarity or pin arrangement.
- Not following the processing notes for soldering of the J-leg terminals may cause solderability problems at the transformer because of pollution with Sn oxyd of the tin bath or burned insulation of the wire. For detailed information see Data Book 2007, chapter “Processing notes, 2.2”.
- The dimensions of the hole arrangement have fixed values and should be understood as a recommendation for drilling the printed circuit board. For dimensioning the pins, the group of holes can only be seen under certain conditions, as they fit into the given hole arrangement. To avoid problems when mounting the transformer, the manufacturing tolerances for positioning the customers’ drilling process must be considered by increasing the hole diameter.

Important notes

The following applies to all products named in this publication:

1. Some parts of this publication contain **statements about the suitability of our products for certain areas of application**. These statements are based on our knowledge of typical requirements that are often placed on our products in the areas of application concerned. We nevertheless expressly point out **that such statements cannot be regarded as binding statements about the suitability of our products for a particular customer application**. As a rule, EPCOS is either unfamiliar with individual customer applications or less familiar with them than the customers themselves. For these reasons, it is always ultimately incumbent on the customer to check and decide whether an EPCOS product with the properties described in the product specification is suitable for use in a particular customer application.
2. We also point out that **in individual cases, a malfunction of passive electronic components or failure before the end of their usual service life cannot be completely ruled out in the current state of the art, even if they are operated as specified**. In customer applications requiring a very high level of operational safety and especially in customer applications in which the malfunction or failure of a passive electronic component could endanger human life or health (e.g. in accident prevention or life-saving systems), it must therefore be ensured by means of suitable design of the customer application or other action taken by the customer (e.g. installation of protective circuitry or redundancy) that no injury or damage is sustained by third parties in the event of malfunction or failure of a passive electronic component.
3. **The warnings, cautions and product-specific notes must be observed.**
4. In order to satisfy certain technical requirements, **some of the products described in this publication may contain substances subject to restrictions in certain jurisdictions (e.g. because they are classed as “hazardous”)**. Useful information on this will be found in our Material Data Sheets on the Internet (www.epcos.com/material). Should you have any more detailed questions, please contact our sales offices.
5. We constantly strive to improve our products. Consequently, **the products described in this publication may change from time to time**. The same is true of the corresponding product specifications. Please check therefore to what extent product descriptions and specifications contained in this publication are still applicable before or when you place an order.
We also **reserve the right to discontinue production and delivery of products**. Consequently, we cannot guarantee that all products named in this publication will always be available.
6. Unless otherwise agreed in individual contracts, **all orders are subject to the current version of the “General Terms of Delivery for Products and Services in the Electrical Industry” published by the German Electrical and Electronics Industry Association (ZVEI)**.
7. The trade names EPCOS, EPCOS-JONES, Baoke, Alu-X, CeraDiode, CSSP, MLSC, PhaseCap, PhaseMod, SIFI, SIFERRIT, SIKOREL, SilverCap, SIMID, SIOV, SIP5D, SIP5K, UltraCap, WindCap are **trademarks registered or pending** in Europe and in other countries. Further information will be found on the Internet at www.epcos.com/trademarks.