



MKV AC capacitors

General AC applications

Ordering code: **B25832**
Date: September 2005

Features

- Compact design
- Long-term stability and reliability

Applications

- For commutation in the low-frequency range

Construction

- Self-healing
- Plastic dielectric
- Oil-impregnated tubular windings (no PCB)
- Metal-sprayed end faces ensure reliable contacting
- Cylindrical aluminum case
- Ceramic or plastic lead-throughs
- Mounting bolts M8 or M12



Terminals

- Tab connectors 6.3 mm
- Dual tab connectors 6.3 mm

Mounting

- If the vibration stress is $\leq 5 g$ and the capacitors are ≤ 60 mm in diameter, the bolt is used for mounting.

Grounding

- Mounting bolts for grounding in accordance with VDE 0100
- Grounding identification in accordance with DIN 40 011

Individual data sheets

Individual data sheets contain detailed specification incl. thermal data. Upon request, these data sheets are available for each capacitor type.

Technical data

Standards		IEC 1071-1/2 EN 61071-1/2 VDE 0560 part 120 and 121
Dielectric dissipation factor	$\tan \delta_0$	$2 \cdot 10^{-4}$
Capacitance tolerance		$\pm 10 \%$
Max. repetitive rate of voltage rise	$(dv/dt)_{\max}$	$\frac{\hat{i}}{C}$
Max. non-repetitive rate of voltage rise	$(dv/dt)_s$	$\frac{I_s}{C}$
Climatic data:		
Min. operating temperature	T_{\min}	$-25 \text{ }^\circ\text{C}$
Max. operating temperature	T_{\max}	$+85 \text{ }^\circ\text{C}$
Average relative humidity		$\leq 75 \%$
Failure quota	$\alpha_{FQ(co)}$	1000 failures per 10^9 component hours
Load duration	$t_{LD(co)}$	up to 30 000 h
Storage temperature limit	T_{stg}	$-55/+85 \text{ }^\circ\text{C}$
IEC climatic category (IEC 68-1 and 2)		25/085/56
Test data:		
AC test voltage		
between terminals	V_{TT}	$1.25 \times V_R, 50 \text{ Hz}, 10 \text{ s}$ (or DC $1.75 \times V_R, 10 \text{ s}$)
between terminals and case	V_{TC}	$2 \cdot V_i + 1000 \text{ V}, 50 \text{ Hz}, 10 \text{ s}$ Insulating voltage $V_i = \text{max. recurrent peak voltage } \hat{v} / \sqrt{2}$
Insulation resistance	R_{ins}	$\leq 1 \text{ } \mu\text{F}: \geq 3000 \text{ M}\Omega$
Self-discharge time constant	$\tau = R_{\text{ins}} \times C$	$> 1 \text{ } \mu\text{F}: \geq 3000 \text{ s}$
Dissipation factor	$\tan \delta$	$\leq 3 \cdot 10^{-4}$

Characteristics and ordering codes

$C_R^{1)}$	I_{\max}	\hat{i}	I_s	R_S 20 °C	L_{self}	Dimensions $d \times l$	Fig.	Appr. weight	Ordering code
μF	A	A	A	m Ω	nH	mm		g	
$V_R = \text{AC } 640 \text{ V}$			$\hat{v} = 800 \text{ V}$			$V_{TT} = \text{AC } 800 \text{ V, } 10 \text{ s}$			
			$v_s = 1100 \text{ V}$			$V_{TC} = \text{AC } 2200 \text{ V, } 10 \text{ s}$			
1.0	10	40	100	24.0	50	25 × 48	3	30	B25832F4105K001
1.5	10	25	60	54.0	90	25 × 80	3	50	B25832F4155K001
1.6	16	60	160	16.0	50	30 × 48	4	50	B25832F4165K001
2.0	16	80	200	13.0	50	30 × 48	4	50	B25832F4205K001
2.2	10	35	90	39.0	90	25 × 80	3	50	B25832F4225K001
2.5	16	100	250	12.0	50	35 × 48	5	60	B25832F4255K001
3.0	10	50	120	30.0	90	25 × 80	3	50	B25832F4305K001
3.0	16	120	300	11.0	50	35 × 48	5	60	B25832F4305K011
3.3	10	50	130	28.0	90	25 × 80	3	50	B25832F4335K001
4.0	16	60	160	24.0	90	30 × 80	4	70	B25832F4405K001
4.7	16	75	190	21.0	90	30 × 80	4	70	B25832F4475K001
5.0	16	80	200	20.0	90	30 × 80	4	70	B25832F4505K001
6.0	18	240	600	5.6	70	45 × 57	1	110	B25832C4605K009
6.8	16	110	270	17.0	90	35 × 80	5	100	B25832F4685K001
7.0	16	110	280	16.0	90	35 × 80	5	100	B25832F4705K001
8.0	18	130	320	12.0	90	40 × 86	1	130	B25832C4805K009
10	18	160	400	10.0	90	40 × 86	1	130	B25832C4106K009
12	18	190	480	9.4	90	45 × 86	1	160	B25832C4126K009
14	18	220	560	8.6	90	50 × 86	1	200	B25832C4146K009
15	18	240	600	8.1	90	50 × 86	1	200	B25832C4156K009
16	18	260	640	7.8	90	50 × 86	1	200	B25832C4166K009
20	18	320	800	7.0	90	55 × 86	1	250	B25832C4206K009
22	18	350	880	6.7	90	60 × 86	1	300	B25832C4226K009
25	18	400	1000	6.2	90	60 × 86	1	300	B25832C4256K009
30	18	480	1200	6.8	140	50 × 156	1	370	B25832C4306K009
33	18	530	1300	6.6	140	50 × 156	1	370	B25832C4336K009
40	18	640	1600	6.2	140	55 × 156	1	450	B25832C4406K009
47	18	750	1900	6.1	140	60 × 156	1	550	B25832C4476K009
50	18	800	2000	5.9	140	60 × 156	1	550	B25832C4506K009

1) Other capacitance values upon request

Characteristics and ordering codes

$C_R^{1)}$	I_{\max}	\hat{i}	I_s	R_S 20 °C	L_{self}	Dimensions $d \times l$	Fig.	Appr. weight	Ordering code
μF	A	A	A	$\text{m}\Omega$	nH	mm		g	
$V_R = \text{AC } 930 \text{ V}$			$\hat{v} = 1200 \text{ V}$			$V_{TT} = \text{AC } 1200 \text{ V, } 10 \text{ s}$			
			$v_s = 1600 \text{ V}$			$V_{TC} = \text{AC } 2700 \text{ V, } 10 \text{ s}$			
1.5	10	45	110	33.0	90	30 × 80	4	70	B25832F6155K001
2.0	10	60	150	26.0	90	30 × 80	4	70	B25832F6205K001
2.5	16	75	190	22.0	90	35 × 80	5	100	B25832F6255K001
3.0	18	90	230	17.0	90	40 × 86	1	130	B25832C6305K009
4.0	18	120	300	14.0	90	40 × 86	1	130	B25832C6405K009
5.0	18	150	380	12.0	90	45 × 86	1	160	B25832C6505K009
5.5	18	170	410	11.0	90	45 × 86	1	160	B25832C6555K009
6.0	18	180	450	10.0	90	50 × 86	1	200	B25832C6605K009
7.0	18	210	530	9.2	90	50 × 86	1	200	B25832C6705K009
8.0	18	240	600	8.5	90	55 × 86	1	250	B25832C6805K009
10	18	300	750	7.5	90	60 × 86	1	300	B25832C6106K009
12	18	360	900	6.7	90	60 × 86	1	300	B25832C6126K009
15	18	450	1100	7.0	110	79.2 × 104	2	600	B25832C6156K009
18	18	540	1400	6.5	110	79.2 × 104	2	600	B25832C6186K009
20	18	600	1500	6.3	110	89.3 × 104	2	800	B25832C6206K009
22	18	660	1700	6.2	110	89.3 × 104	2	800	B25832C6226K009

1) Other capacitance values upon request

Dimensional drawing 1

Dual tab connectors 6.3 mm

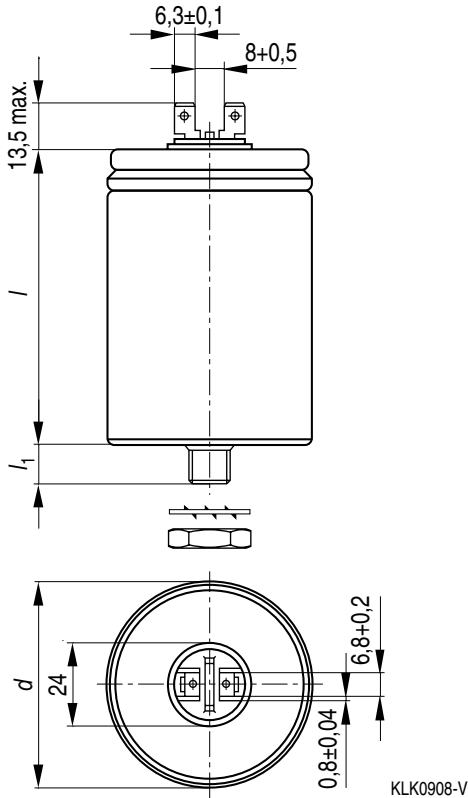
Dimensional drawing 2

Dual tab connectors 6.3 mm

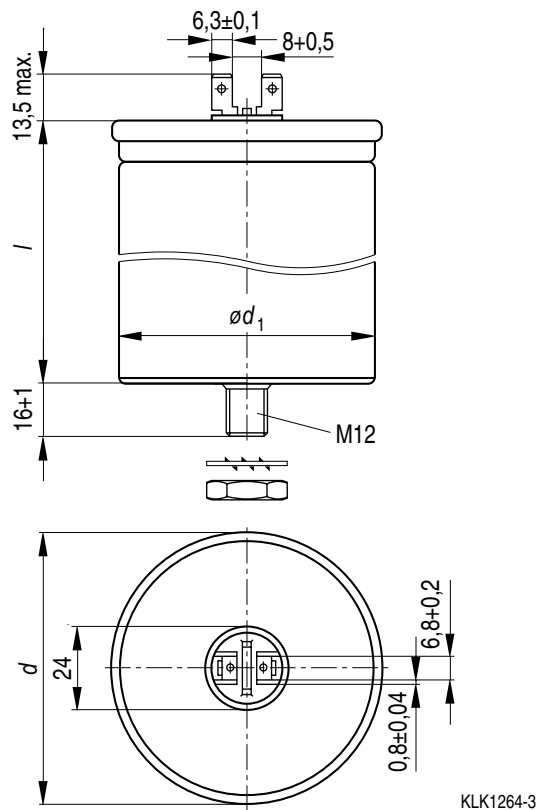

Dimensions in mm

$d_{-0.2}^{+0.5}$	l_{-2}^{+1}	l_{1+1}^*	Creepage distance	Clearance
40	86	8	7	5
45	57	8		
45	86	8		
50	86	12		
50	156	12		
55	86	12		
55	156	12		
60	86	12		
60	156	12		

Dimensions in mm

$d-1.2$	$l-4$	$\varnothing d_1-0.4$	Creepage distance	Clearance
79.2	104	75.2	7	5
89.3	104	85.2		

*) 8 mm = threaded bolt M8
12 mm = threaded bolt M12

Mounting parts (included in delivery)

Threaded bolt	Max. torque	Toothed washer	Hex nut
M8	4 Nm	J 8.2 DIN 6797	M 8 DIN 439
M12	10 Nm	J 12.5 DIN 6797	M12 DIN 439

Dimensional drawing 3

Tab connectors 6.3 mm

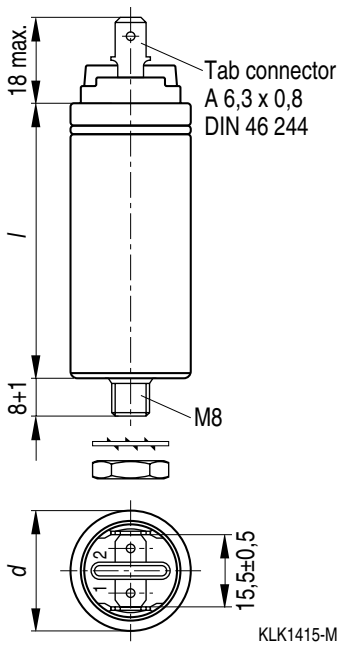

KLK1415-M

Dimensional drawing 4

Tab connectors 6.3 mm

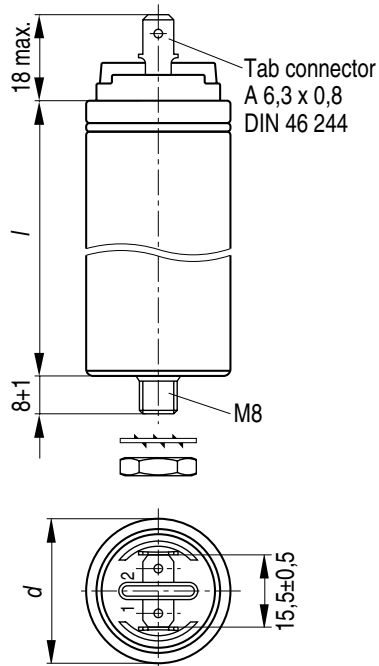

KLK1416-V

Dimensions in mm

$d \begin{smallmatrix} +0,5 \\ -0,2 \end{smallmatrix}$	$l \pm 2$	Creepage distance	Clearance
25	48	9	7
25	80		

Dimensions in mm

$d \begin{smallmatrix} +0,5 \\ -0,2 \end{smallmatrix}$	$l \pm 2$	Creepage distance	Clearance
30	48	9	7
30	80		

Mounting parts (included in delivery)

Threaded bolt	Max. torque	Toothed washer	Hex nut
M8	4 Nm	J 8.2 DIN 6797	M8 DIN 439

Dimensional drawing 5

Tab connectors 6.3 mm

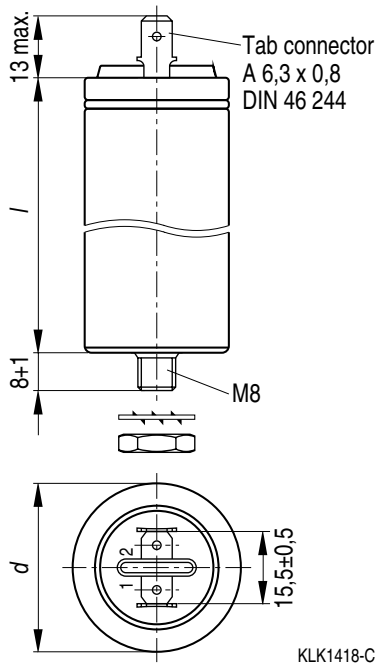

Dimensions in mm

$d_{+0,5}^{-0,2}$	$l \pm 2$	Creepage distance	Clearance
35	48	6	6
35	80		

Mounting parts (included in delivery)

Threaded bolt	Max. torque	Toothed washer	Hex nut
M8	4 Nm	J 8.2 DIN 6797	M8 ISO 4035

Cautions and warnings

Safety

- In case of dents of more than 1 mm depth or any other mechanical damage, capacitors must not be used at all. This applies also in cases of oil leakage.
- Electrical or mechanical misapplication of capacitors may be hazardous. Personal injury or property damage may result from bursting of the capacitor or from expulsion of oil or melted material due to mechanical disruption of the capacitor.
- Ensure good, effective grounding for capacitor enclosures.
- Observe appropriate safety precautions during operation (self-recharging phenomena and the high energy contained in capacitors).
- Handle capacitors carefully, because they may still be charged even after disconnection.
- The terminals of capacitors, connected bus bars and cables as well as other devices may also be energized.
- Follow good engineering practice.
- Failure to follow cautions may result, worst case, in premature failures, bursting and fire.

Thermal load

After installation of the capacitor it is necessary to verify that maximum hot-spot temperature is not exceeded at extreme service conditions (see www.epcos.com/thermal_design/).

Mechanical protection

The capacitor has to be installed in a way that mechanical damages and dents in the aluminum can be avoided.

Storage and Operating Conditions

Do not use or store capacitors in corrosive atmosphere especially where chloride gas, sulfide gas, acid, alkali, salt or the like are present. In dusty environments, regular maintenance and cleaning especially of the terminals is required to avoid conductive path between phases and/or phases and ground.

Overpressure disconnecter

To ensure full functionality of an overpressure disconnecter, the following must be observed:

- The elastic elements must not be hindered, i.e.
 - connecting lines must be flexible leads (cables),
 - there must be sufficient space (minimum 12 mm) above the connections for expansion of the overpressure disconnecter,
 - folding crimps must not be retained by clamps.
- Stress parameters of the capacitor must be within the IEC61071 specification.

Service life expectancy

Electrical components do not have an unlimited service life expectancy; this applies to self-healing capacitors too. The maximum service life expectancy may vary depending on the application the capacitor is used in.

Important notes

The following applies to all products named in this publication:

1. Some parts of this publication contain **statements about the suitability of our products for certain areas of application**. These statements are based on our knowledge of typical requirements that are often placed on our products in the areas of application concerned. We nevertheless expressly point out **that such statements cannot be regarded as binding statements about the suitability of our products for a particular customer application**.
As a rule, EPCOS is either unfamiliar with individual customer applications or less familiar with them than the customers themselves. For these reasons, it is always ultimately incumbent on the customer to check and decide whether an EPCOS product with the properties described in the product specification is suitable for use in a particular customer application.
2. We also point out that **in individual cases, a malfunction of passive electronic components or failure before the end of their usual service life cannot be completely ruled out in the current state of the art, even if they are operated as specified**. In customer applications requiring a very high level of operational safety and especially in customer applications in which the malfunction or failure of a passive electronic component could endanger human life or health (e.g. in accident prevention or life-saving systems), it must therefore be ensured by means of suitable design of the customer application or other action taken by the customer (e.g. installation of protective circuitry or redundancy) that no injury or damage is sustained by third parties in the event of malfunction or failure of a passive electronic component.
3. **The warnings, cautions and product-specific notes must be observed.**
4. In order to satisfy certain technical requirements, **some of the products described in this publication may contain substances subject to restrictions in certain jurisdictions (e.g. because they are classed as “hazardous”)**. Useful information on this will be found in our Material Data Sheets on the Internet (www.epcos.com/material). Should you have any more detailed questions, please contact our sales offices.
5. We constantly strive to improve our products. Consequently, **the products described in this publication may change from time to time**. The same is true of the corresponding product specifications. Please check therefore to what extent product descriptions and specifications contained in this publication are still applicable before or when you place an order.
We also **reserve the right to discontinue production and delivery of products**. Consequently, we cannot guarantee that all products named in this publication will always be available.
6. Unless otherwise agreed in individual contracts, **all orders are subject to the current version of the “General Terms of Delivery for Products and Services in the Electrical Industry” published by the German Electrical and Electronics Industry Association (ZVEI)**.
7. The trade names EPCOS, CeraDiode, CSSP, PhaseCap, PhaseMod, SilverCap, SIFI, SIMID, SIKOREL, SIOV, SIP5D, SIP5K, TOPcap, UltraCap, WindCap are **trademarks registered or pending** in Europe and in other countries. Further information will be found on the Internet at www.epcos.com/trademarks.