

Features and Benefits

- Peak output current up to 1200mA
- Low start-up voltage
- Low output resistance
- High sensitivity integrated Hall Sensor
- Power-efficient CMOS and power MOSFETs
- Built-in output protection clamping diode
- Locked rotor protection and auto-restart
- Integrated tachometer (US890) or alarm (US891) signal protected output
- Low cost
- 2-coil fan driver with FG/RD output in RoHS Compliant 4-pin VK package

Application Examples

- 5V/12V DC brushless motor/fan
- PC, server, laptop cooling fan
- Power supply cooling fan
- Large and small fan size

Ordering Code

Product Code	Temperature Code	Package Code	Option Code	Packing Form Code
US891	E	VK	AAA-000	BU
US890	E	VK	AAA-000	BU

Legend:

Temperature Code: E for Temperature Range -40 °C to 85 °C
 Package Code: VK for Plastic Single in Line
 Packing Form: BU for Bulk

Ordering example: US891EVK-AAA-000-BU

1 Functional Diagram

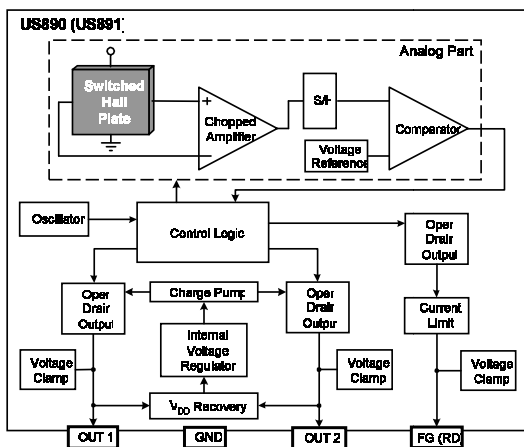

2 General Description

The US890/891 is a one-chip solution for driving two-coil brushless DC motors and fans.

Based on the advanced Melexis CMOS process, the IC contains a Hall-effect sensor, dynamic offset correction and powerful output drivers with 1200mA peak output current capability.

Specially designed for driving large fans, the device is optimized for low start-up voltage.

Frequency Generator or Rotation Detection is available. The open-drain output makes easier the connectivity with any external interface such as hardware monitoring or Super I/O IC.

These features are combined with the Melexis patented no- V_{DD} design to fit the IC in a small 4-pin VK package.

Table of Contents

1 Functional Diagram	1
2 General Description.....	1
3 Glossary of Terms	3
4 Absolute Maximum Ratings	3
5 Pin Definitions and Descriptions.....	3
6 General Electrical Specifications	4
7 Magnetic Specifications	4
8 Driver Output vs Magnetic Pole.....	4
9 Detailed General Description	5
10 Unique Features.....	5
11 Performance Graphs	7
11.1 R_{DSON} vs T_A	7
11.2 R_{DSON} vs V_{DD}	7
11.3 Magnetic parameters vs T_A	7
11.4 Magnetic parameters vs V_{DD}	7
11.5 I_{DD} vs T_A	7
11.6 I_{DD} vs V_{DD}	7
12 Test conditions	8
12.1 V_{DD} – operating	8
12.2 R_{DSON}	8
12.3 I_{DD}	8
12.4 FG/RD Output Low Voltage	8
13 Application Information.....	9
13.1 Typical application circuit	9
13.2 Recommended circuit for ground disconnection protection.....	9
14 Application Comments	9
15 Standard information regarding manufacturability of Melexis products with different soldering processes.....	10
16 ESD Precautions	10
17 VK Package Information (4-pin TO-92).....	11
18 Disclaimer.....	12

3 Glossary of Terms

Two-coil fan	A fan with two-coil windings where current alternates from 1 coil to the other depending on the direction of the magnetic field.
MilliTesla (mT), Gauss	Units of magnetic flux density : 1mT = 10 Gauss
V _{DD}	Voltage on the common point of the fan coils.
I _{DD}	Current supplying the chip which flows through the coil connected to the switched off output driver.
Peak output current	The current flowing in the coil at start-up, only limited by the coil resistance R _{COIL} and the output driver resistance R _{DSON} .
Continuous output current	The average current flowing in the coil when the fan is spinning normally.
Locked rotor	The state when the fan stopped spinning due to mechanical blockage.
FG	Frequency generator or tachometer output
RD	Rotation detection or alarm output

4 Absolute Maximum Ratings

Parameter	Symbol	Value	Units
Fan Supply Voltage	V _{DD}	18	V
Peak Output Current	I _{OUTP}	1200	mA
Continuous Output Current	I _{OUTC}	600	mA
FG/RD Pull-Up Voltage	V _{FG, RD}	18	V
FG/RD Reverse Current	I _{FG_REV, RD_REV}	60	mA
Operating Temperature Range	T _A	-40 to 85	°C
Junction Temperature	T _J	125	°C
Storage Temperature Range	T _S	-55 to 150	°C
Magnetic Flux Density	B	Unlimited	mT
ESD Sensitivity (AEC Q100 002)	-	4	kV

Table 1: Absolute maximum ratings

Exceeding the absolute maximum ratings may cause permanent damage. Exposure to absolute-maximum-rated conditions for extended periods may affect device reliability.

5 Pin Definitions and Descriptions

Pin Name	Pin number	Function
FG (RD)	1	Frequency Generator (Rotation Detection) Open Drain Output
OUT1	2	Open Drain Coil Driver 1
OUT2	3	Open Drain Coil Driver 2
GND	4	Ground pin

Table 2: Pin definitions and descriptions

6 General Electrical Specifications

DC Operating Parameters $T_A = 25^\circ\text{C}$, $V_{DD} = 12\text{V}$ (unless otherwise specified)

Parameter	Symbol	Test Conditions	Min	Typ	Max	Units
Fan Supply Voltage	V_{DD}	Operating – $R_{COIL} = 100\Omega$	2.6 ⁽¹⁾	12	18	V
Supply Current	I_{DD}			2.5	4	mA
OUT1, OUT2 ON Resistance	$R_{DSON\ 1,2}$	$V_{DD} = 5\text{V}$, $T_A = 25^\circ\text{C}$, $I_{OUT} = 300\text{mA}$		1	1.4	Ω
OUT1, OUT2 ON Resistance	$R_{DSON\ 1,2}$	$V_{DD} = 5\text{V}$, $T_J = 125^\circ\text{C}$, $I_{OUT} = 300\text{mA}$		1.8	2.5	Ω
OUT1, OUT2 Output Clamp Voltage	$V_{OUT1,2}$		36			V
FG / RD Output Low Voltage	V_{OL}	$I_{OL} = 4\text{mA}$		0.33	0.5	V
FG / RD Output Clamp Voltage	V_{CLMP}		18	25		V
FG / RD Output Leakage Current	I_{LEAK}	$V_{FG}(V_{RD}) = 5\text{V}$		0.15	10	μA
FG / RD Output Current Limit	I_{FGLM}	$V_{FG}(V_{RD}) = 12\text{V}$		23		mA
Package Thermal Resistance	R_{TH}	One-sided PCB, zero LFPM		200		$^\circ\text{C}/\text{Watt}$
Locked Rotor Period	T_{ON}	$V_{DD} > 7\text{V}$		0.25		s
Locked Rotor Period	T_{OFF}	$V_{DD} > 7\text{V}$		1.5		s
Locked Rotor Period	T_{ON}	$V_{DD} < 5.5\text{V}$	0.37	0.53 ⁽²⁾	0.75	s
Locked Rotor Period	T_{OFF}	$V_{DD} < 5.5\text{V}$	2.25	3.2 ⁽²⁾	4.51	s
Output Switching Delay	T_{DELAY}	“Dead time” when both drivers are off		50		μs

Table 3: Electrical specifications

Note 1: The minimal value of V_{DD} should be determined using the following equation:

$$V_{DD} = 2.5\text{V} + R_{COIL} * I_{DD}$$

Note 2: Typical values valid at 5.5V. The values increase at lower voltage to improve fan start-up reliability.

7 Magnetic Specifications

DC Operating Parameters $T_A = 25^\circ\text{C}$, $V_{DD} = 12\text{V}$ (unless otherwise specified)

Parameter	Symbol	Test Conditions	Min	Typ	Max	Units
Operate point	B_{OP}		0		6	mT
Release point	B_{RP}		-6		0	mT
Hysteresis	B_{HYST}		2	4.5	10	mT

Table 4: Magnetic specifications

8 Driver Output vs Magnetic Pole

Parameter	Test Conditions	OUT1	OUT2	FG
North pole	$B < B_{rp}$	High	Low	High
South pole	$B > B_{op}$	Low	High	Low

Table 5: Driver output vs magnetic pole

Note 1: The magnetic pole is applied facing the branded side of the package

9 Detailed General Description

The US890/891 is a one-chip solution for driving two-coil brushless DC motors and fans. Based on advanced Melexis CMOS process, the chip contains a Hall-effect sensor, dynamic offset correction and powerful output drivers with 1200mA peak output current capability.

The low side output coil drivers are fully protected against switching transients. So an external zener diode is not needed to cut the high voltage spikes induced by the motor coils.

The US890 has an open-drain integrated tachometer FG output that follows the Hall signal. In the US891, the open-drain rotation detection output RD is active low during normal spinning of the motor. It goes high when the flux switching frequency becomes too low, which means the motor is blocked.

10 Unique Features

Specially designed for driving large fans, both ICs have LRP characteristics optimised for low start-up voltage. At low V_{DD} , fans typically take longer to start up than at higher V_{DD} .

The motor start-up phase (from zero to maximum rotation speed) is illustrated below. Big fans with large inertia may have slow start-up causing a longer first output pulse after power-on. If this pulse duration is longer than the LRP T_{ON} period, the fan may falsely enter locked rotor condition.

The US890/891 provides an adequate and simple solution to prevent this by automatically adjusting the LRP period at low voltage. It directly improves the motor start-up reliability.

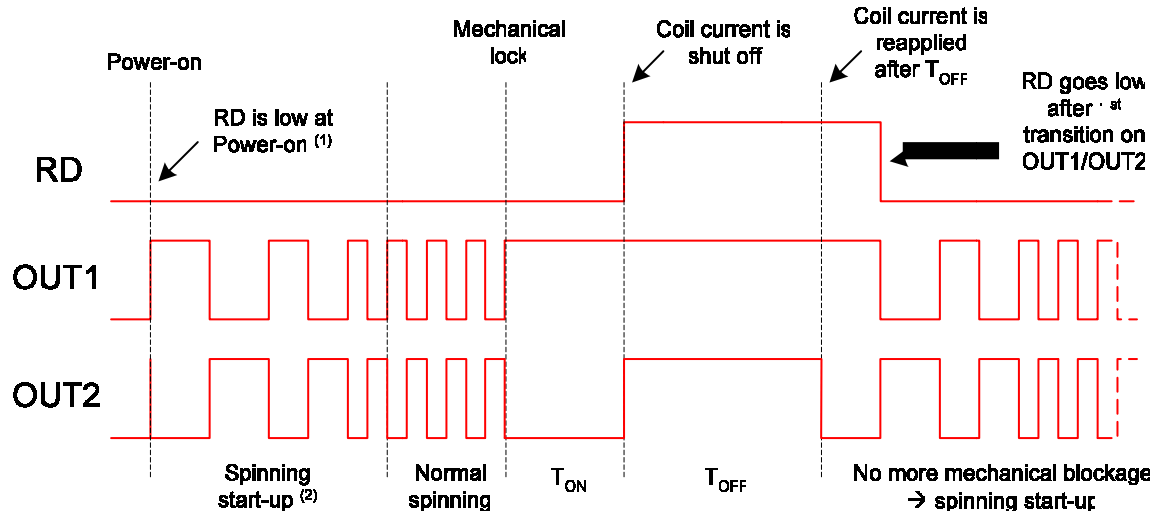

Note 1 : At Power-on, RD is low. If no transition occurs on OUT1/OUT2 before T_{ON} time, RD goes high.

Note 2 : The spinning start-up is the ramp between the zero speed and maximal speed. It depends on the motor characteristics.

Note 3 : This graph does not represent the EMF effect.

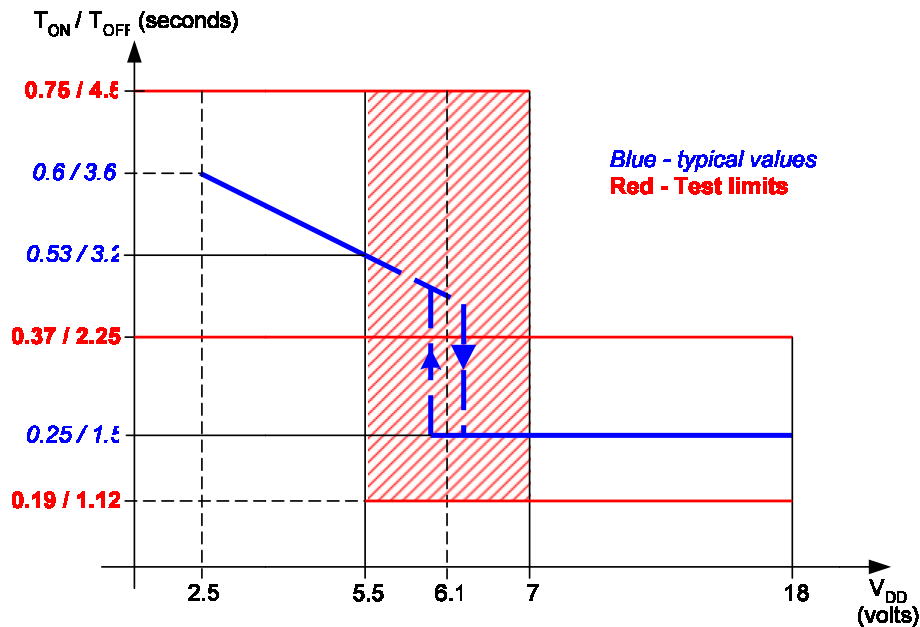

According to the electrical specification table and the figure above, three behaviours can occur:

- $V_{DD} < 5.5V$, T_{ON}/T_{OFF} time periods are longer (from 0.53s / 3.2s typical at 5.5V)
The periods increase with operating voltage to improve start-up at very low voltage.
- $V_{DD} > 7V$, T_{ON}/T_{OFF} time periods are shorter (0.25s / 1.5s typical)
The periods at high voltage are about twice as short as at low voltage
- $5.5V < V_{DD} < 7V$, the switching event may slightly vary, but is kept within these limits.
A small hysteresis is implemented to avoid oscillation around the threshold voltage.
The typical mean threshold between the hysteresis is around 6.1V ($T_A=25\text{ }^\circ\text{C}$).

This facilitates driving heavier fans and motors with large inertia without any external component (T_{ON}/T_{OFF} is increased or decreased depending on the fan supply voltage V_{DD}).

The FG/RD output driver provides an over current protection limiting the current flowing in the FG/RD driver while switched ON. It can occur if a too small pull-up resistor is used or if this resistor is short connected. This protection reduces the risk of EOS damage on the FG/RD driver.

11 Performance Graphs

11.1 $R_{DS(on)}$ vs T_A

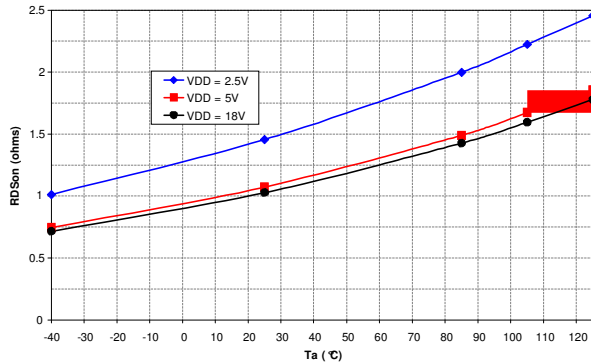

11.2 $R_{DS(on)}$ vs V_{DD}

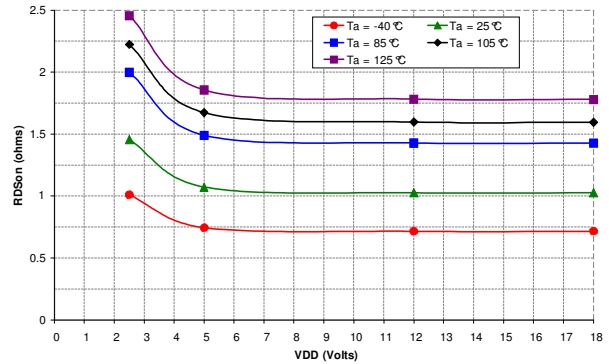

11.3 Magnetic parameters vs T_A

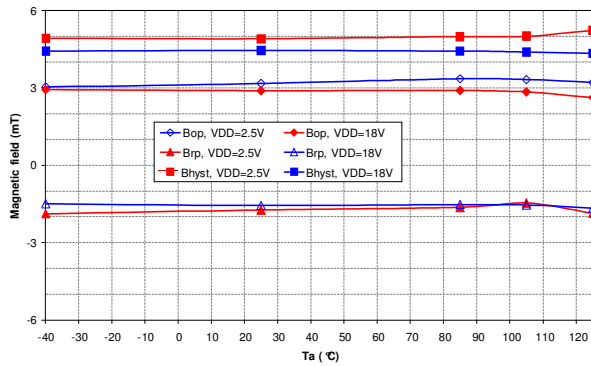

11.4 Magnetic parameters vs V_{DD}

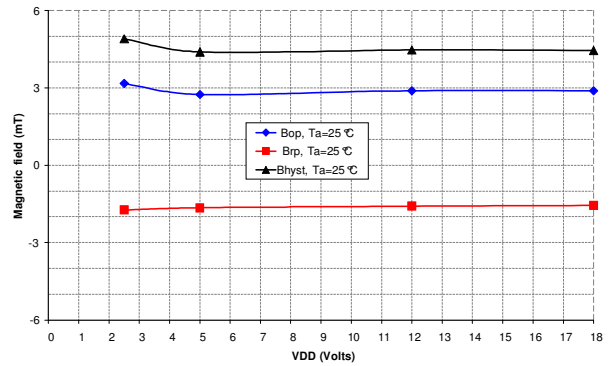

11.5 I_{DD} vs T_A

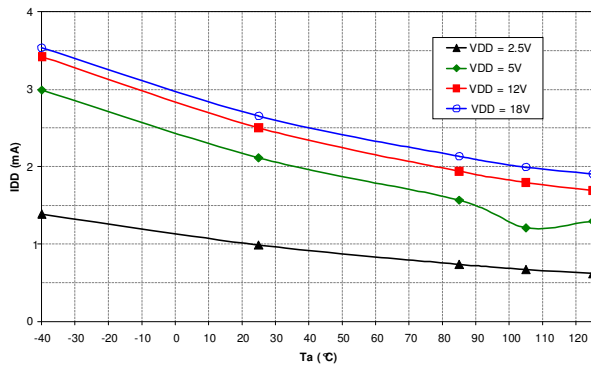

11.6 I_{DD} vs V_{DD}

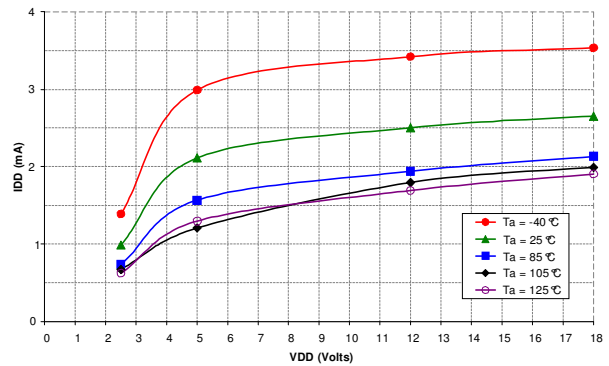

12 Test conditions

12.1 V_{DD} – operating

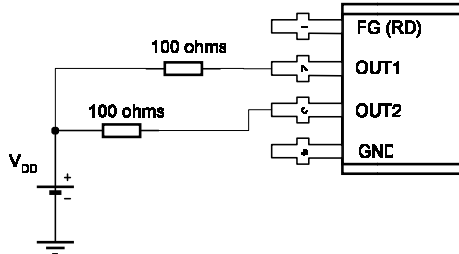

Note 1 - "Operating" states the condition when the IC functions according to the specification.

12.2 R_{DSON}

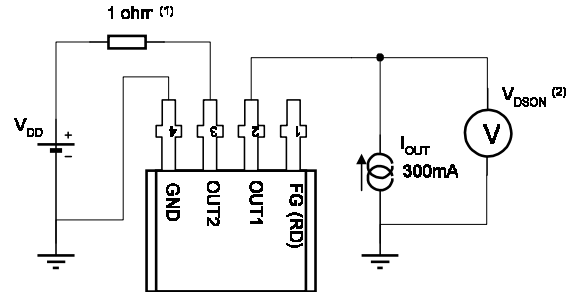

Note 1 - The IC is triggered to have OUT2 = high and OUT1 = low. A small resistor value is used to have V_{DD} equal to V_{OUT2}

Note 2 - V_{DSON} is measured just after the power-on in order to have the junction temperature T_j equal to ambient temperature T_A

Note 3 - The output driver resistance R_{DSON} is calculated via the relation:
 $R_{DSON} = V_{DSON} / I_{OUT}$

12.3 I_{DD}

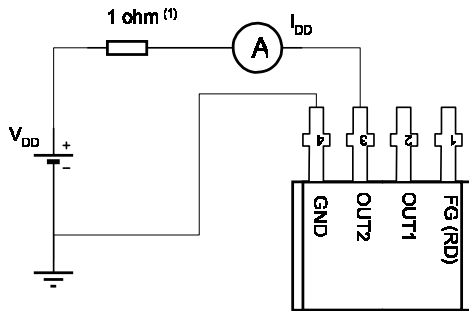

Note 1 - The IC is triggered to have OUT2 = high and OUT1 = low. A small resistor value is used to have V_{DD} equal to V_{OUT2}

12.4 FG/RD Output Low Voltage

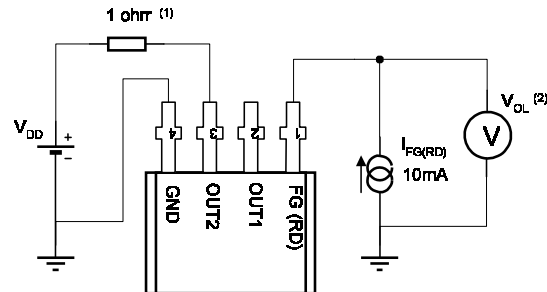

Note 1 - The IC is triggered to have OUT2 = high and OUT1 = low. A small resistor value is used to have V_{DD} equal to V_{OUT2}

Note 2 - The FG/RD output low voltage is measured during the first T_{ON} period at the power-on event.

13 Application Information

13.1 Typical application circuit

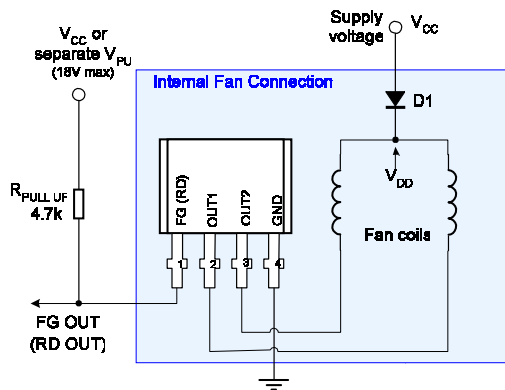

13.2 Recommended circuit for ground disconnection protection

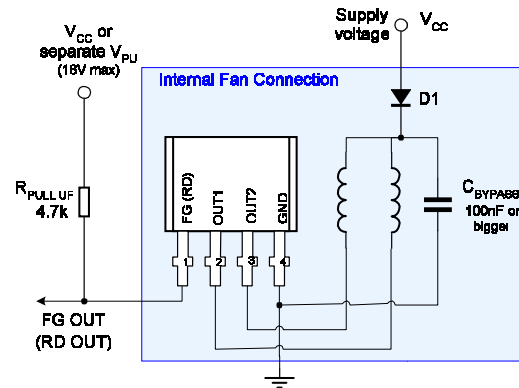

14 Application Comments

The application 13.1 shows the typical application including a diode D1 for additional reverse voltage protection. Without this diode, the reverse current in each coil is equal to the fan peak current, as it is only limited by its coil resistances. In some fan construction where the peak current is not so big, this situation may be acceptable by both IC and coils for short period of time. However, a long exposure may seriously affect the reliability or damage each of them by overheating.

The diode D1 connected in series between the supply voltage and the common point of the coils prevents this reverse current to flow. It prevents such reverse voltage damage and best protects both IC and coils.

The application 13.2 is given in case the ground connection might be disconnected while the fan operates. At this moment, the current flowing through the coils may circulate from the output (OUT1 or OUT2) to the FG/RD output driver in reverse direction. High reverse current may damage the logic output driver.

A bypass capacitor connected between the coil common node and the device ground should prevent such damage occurring by providing a close path to this current.

The value of the capacitor needs to be tuned with the motor characteristics. Higher inductance may require higher capacitor value.

For 2-wire fan application (tachometer or alarm logical output not required), the FG/RD pin (#1) should be connected to the device ground pin (#4).

15 Standard information regarding manufacturability of Melexis products with different soldering processes

Our products are classified and qualified regarding soldering technology, solderability and moisture sensitivity level according to following test methods:

Reflow Soldering SMD's (Surface Mount Developments)

- IPC/JEDEC J-STD-020
Moisture/Reflow Sensitivity Classification for Nonhermetic Solid State Surface Mount Devices (classification reflow profiles according to table 5-2)
- EIA/JEDEC JESD22-A113
Preconditioning of Nonhermetic Surface Mount Devices Prior to Reliability Testing (reflow profiles according to table 2)

Wave Soldering SMD's (Surface Mount Developments) and THD's (Through Hole Developments)

- EN60749-20
Resistance of plastic- encapsulated SMD's to combined effect of moisture and soldering heat
- EIA/JEDEC JESD22-B106 and EN60749-15
Resistance to soldering temperature for through-hole mounted devices

Iron Soldering THD's (Through Hole Developments)

- EN60749-15
Resistance to soldering temperature for through-hole mounted devices

Solderability SMD's (Surface Mount Developments) and THD's (Through Hole Developments)

- EIA/JEDEC JESD22-B102 and EN60749-21
Solderability

For all soldering technologies deviating from above mentioned standard conditions (regarding peak temperature, temperature gradient, temperature profile etc) additional classification and qualification tests have to be agreed upon with Melexis.

The application of Wave Soldering for SMD's is allowed only after consulting Melexis regarding assurance of adhesive strength between device and board.

Melexis is contributing to global environmental conservation by promoting **lead free** solutions. For more information on qualifications of **RoHS** compliant products (RoHS = European directive on the Restriction Of the use of certain Hazardous Substances) please visit the quality page on our website:
<http://www.melexis.com/quality.aspx>

16 ESD Precautions

Electronic semiconductor products are sensitive to Electro Static Discharge (ESD). Always observe Electro Static Discharge control procedures whenever handling semiconductor products.

17 VK Package Information (4-pin TO-92)

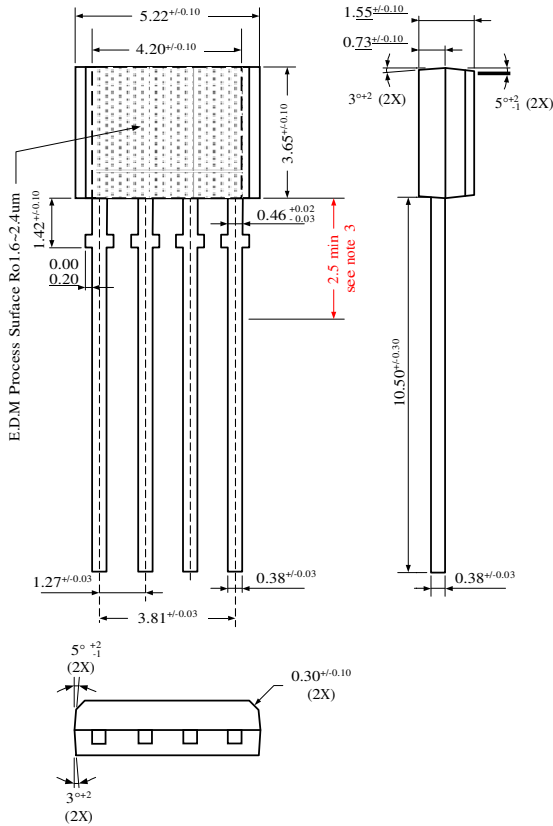

Notes:

1. All dimensions are in millimeters
2. Package dimension exclude molding flash. Mold flash shall not exceed 0.127mm.
3. To preserve reliability, it is recommended to have total lead length equal to 2.5mm minimum, measured from the package line.
4. VK package is a pin though-hole package, hence adapted for wave soldering process. A reflow soldering process is not recommended with VK package as it may seriously affect device reliability.

Marking:

- 1st Line : US890 (US891) - Name of the device
 2nd Line : XXYWW
 XX - lot number (last 2 digits)
 Y - assembly year (last digit)
 WW - assembly week number

Hall plate location

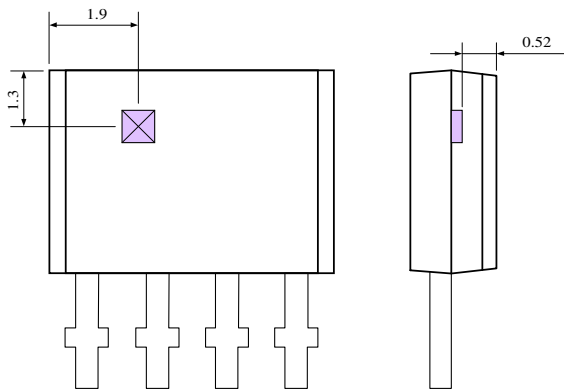

Notes:

1. All dimensions are in millimeters

18 Disclaimer

Devices sold by Melexis are covered by the warranty and patent indemnification provisions appearing in its Term of Sale. Melexis makes no warranty, express, statutory, implied, or by description regarding the information set forth herein or regarding the freedom of the described devices from patent infringement. Melexis reserves the right to change specifications and prices at any time and without notice. Therefore, prior to designing this product into a system, it is necessary to check with Melexis for current information. This product is intended for use in normal commercial applications. Applications requiring extended temperature range, unusual environmental requirements, or high reliability applications, such as military, medical life-support or life-sustaining equipment are specifically not recommended without additional processing by Melexis for each application.

The information furnished by Melexis is believed to be correct and accurate. However, Melexis shall not be liable to recipient or any third party for any damages, including but not limited to personal injury, property damage, loss of profits, loss of use, interrupt of business or indirect, special incidental or consequential damages, of any kind, in connection with or arising out of the furnishing, performance or use of the technical data herein. No obligation or liability to recipient or any third party shall arise or flow out of Melexis' rendering of technical or other services.

© 2012 Melexis NV. All rights reserved.

For the latest version of this document, go to our website at
www.melexis.com

Or for additional information contact Melexis Direct:

Europe, Africa, Asia:

Phone: +32 1367 0495

E-mail: sales_europe@melexis.com

America:

Phone: +1 248 306 5400

E-mail: sales_usa@melexis.com

ISO/TS 16949 and ISO14001 Certified