

Features

- ❑ Fully compliant to GMW3089 V2.4 and J2411 Single Wire CAN specification for Class B in-vehicle communications
- ❑ Only 60 μ A worst case sleep mode current independent from CAN voltage range
- ❑ Operating voltage range 5V to 26.5V
- ❑ Up to 40 kbps bus speed
- ❑ Up to 100 kbps high-speed transmission mode
- ❑ Logic inputs compatible with 3.3V and 5V supply systems
- ❑ Control pin for external voltage regulators
- ❑ Low RFI due to output wave shaping in normal and high voltage wake up mode
- ❑ Fully integrated receiver filter
- ❑ Bus terminals proof against short-circuits and transients in automotive environment
- ❑ Loss of ground protection, very low leakage current (typ. 20 μ A at 26.5V and 125°C)
- ❑ Protection against load dump, jump start
- ❑ Thermal overload and short circuit protection
- ❑ Under voltage lockout
- ❑ Bus dominant time-out feature
- ❑ Pb-Free 14-pin thermally enhanced and 8-pin SOIC package

Ordering Code

Product Code	Temperature Code	Package Code	Option Code	Packing Form Code
TH8056	K	DC	AAA-008	TU
TH8056	K	DC	AAA-008	RE
TH8056	K	DC	AAA-014	TU
TH8056	K	DC	AAA-014	RE

Legend:

Temperature Code: K for Temperature Range -40°C to 125°C
 Package Code: DC for SOIC150Mil
 Option Code: XXX-008 for 8 Leads, XXX-014 for 14 Leads.
 Packing Form: RE for Reel, TU for Tube

Ordering example: TH8056KDC-AAA-008-TU

General Description

The TH8056 is a physical layer device for a single wire data link capable of operating with various CSMA/CR protocols such as the Bosch Controller Area Network (CAN) version 2.0. This serial data link network is intended for use in applications where a high data rate is not required and a lower data rate can achieve cost reductions in both the physical media components and the microprocessor and/or dedicated logic devices that use the network.

The network shall be able to operate in either the normal data rate mode or the high-speed data download mode for assembly line and service data transfer operations. The high-speed mode is only intended to be operational when the bus is attached to an off-board service node. This node shall provide temporary bus electrical loads which facilitate higher speed operation.

The bit rate for normal communications is typically 33.33kbit/s, for high-speed transmissions as described above a typical bit rate of 83.33kbit/s is recommended. The TH8056 is designed in accordance with the Single Wire CAN Physical Layer Specification GMW3089 V2.4 and supports many additional features like under-voltage lock-out, time-out for faulty blocked input signals, output blanking time in case of bus ringing and a very low sleep mode current.

Contents

1. Functional Diagram	5
2. Electrical Specification	6
2.1 Operating Conditions.....	6
2.2 Absolute Maximum Ratings.....	6
2.3 Static Characteristics.....	7
2.4 Dynamic Characteristics.....	9
2.5 Bus loading requirements.....	10
2.6 Timing Diagrams	12
3. Functional Description.....	14
3.1 TxD Input pin.....	14
3.2 Mode 0 and Mode 1 pins.....	15
3.3 RxD Output pin.....	16
3.4 Bus LOAD pin.....	16
3.5 V _{bat} INPUT pin.....	17
3.6 CAN BUS pin.....	17
3.7 INH Pin (TH8056 KDC A only).....	17
3.8 State Diagram.....	19
3.9 Power Dissipation.....	20
3.9.1 Thermal behaviour of TH8056 with SOIC8 – TH8056 KDC A8	21
3.10 Application Circuitry.....	23
4. Pin Description	24
5. Package Dimensions.....	26
5.1 SOIC14.....	26
5.2 SOIC8.....	27
6. Tape and Reel Specification	28
6.1 Tape Specification.....	28
6.2 Reel Specification for SOIC14NB.....	29
7. ESD/EMC Remarks	30
7.1 General Remarks	30
7.2 ESD-Test.....	30
7.3 EMC	30
7.4 Latch Up Test.....	30
8. Revision History	31



TH8056

Enhanced Single Wire CAN Transceiver

9. Standard information regarding manufacturability of Melexis products with different soldering processes.....	33
10. Disclaimer	34

1. Functional Diagram

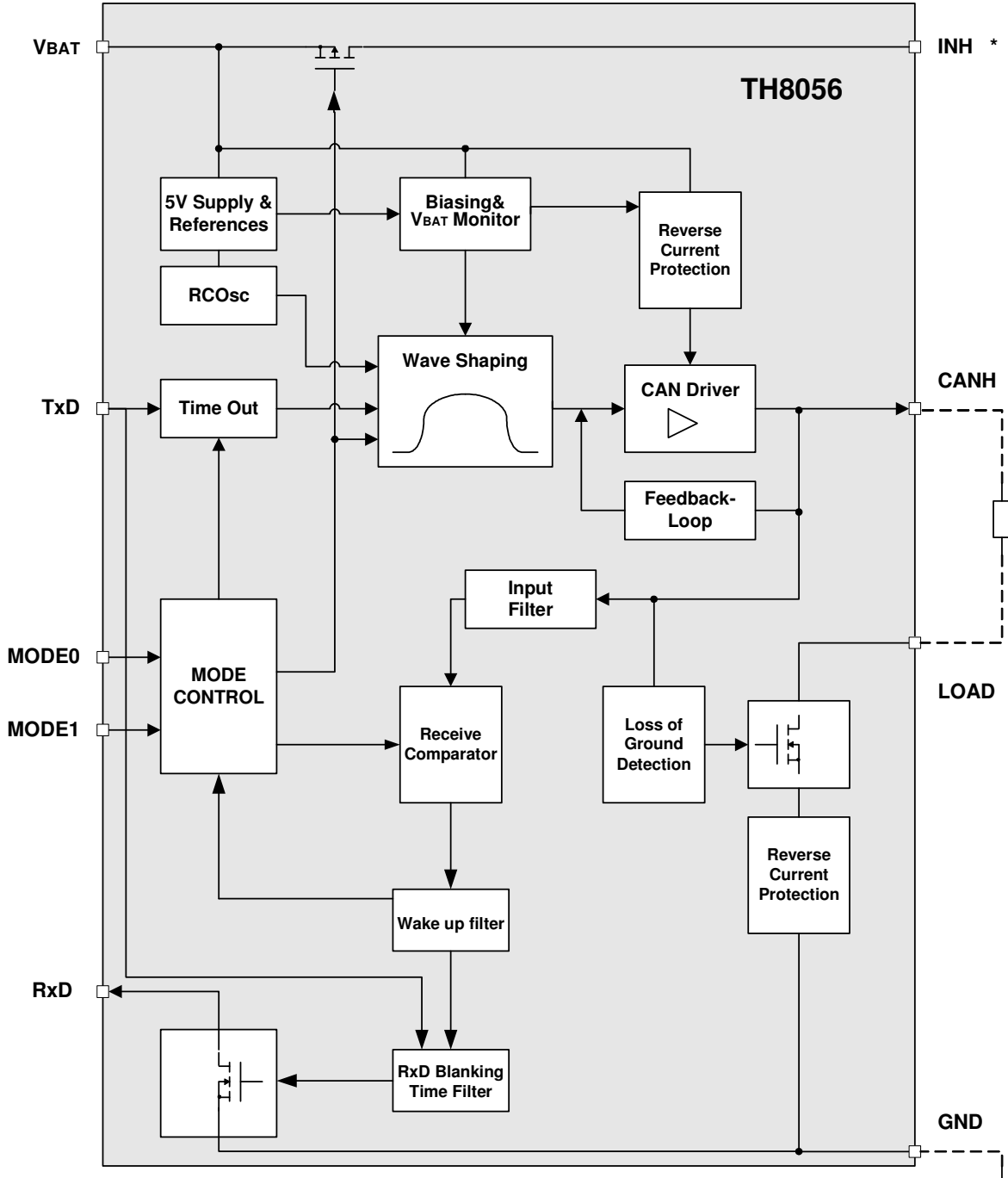

Figure 1 - Block Diagram

* INH terminal is present on TH8056 KDC A only

2. Electrical Specification

All voltages are referenced to ground (GND). Positive currents flow into the IC.
 The absolute maximum ratings (in accordance with IEC 134) given in the table below are limiting values that do not lead to a permanent damage of the device but exceeding any of these limits may do so. Long term exposure to limiting values may affect the reliability of the device.

2.1 Operating Conditions

Parameter	Symbol	Min	Max	Unit
Battery voltage	V _{BAT}	5.0	18	V
Operating ambient temperature for TH8056 KDC A	T _A	-40	125	°C
Junction temperature	T _J	-40	150	°C

2.2 Absolute Maximum Ratings

Parameter	Symbol	Condition	Min	Max	Unit
Supply Voltage	V _{BAT}		-0.3	18	V
Short-term supply voltage	V _{BAT,ld}	Load dump; t<500ms		40	V
		Jump start; t<1min		26.5	
Transient supply voltage	V _{BAT.tr1}	ISO 7637/1 pulse 1 ^[1]	-50		V
Transient supply voltage	V _{BAT.tr2}	ISO 7637/1 pulses 2 ^[1]		100	V
Transient supply voltage	V _{BAT.tr3}	ISO 7637/1 pulses 3A, 3B	-200	200	V
CANH voltage	V _{CANH}	V _{BAT} <= 26.5V	-20	40	V
		V _{BAT} = 0	-40	40	
Transient bus voltage	V _{CANH.tr1}	ISO 7637/1 pulse 1 ^[2]	-50		V
Transient bus voltage	V _{CANH.tr2}	ISO 7637/1 pulses 2 ^[2]		100	V
Transient bus voltage	V _{CANH.tr3}	ISO 7637/1 pulses 3A, 3B ^[2]	-200	200	V
DC voltage on pin LOAD	V _{LOAD}	via R _T > 2kΩ	-40	40	V
DC voltage on pins TxD, MODE1, MODE0,RxD,	V _{DC}		-0.3	7	V
ESD capability of any pin (Human Body Model)	ESD _{HBM}	Human body model, equivalent to discharge 100pF with 1.5kΩ,	-2	2	kV
Maximum latch – up free current at any Pin	I _{LATCH}		-500	500	mA
Thermal impedance ^[3]	Θ _{JA}	in free air, SOIC14		70	K/W
		in free air, SOIC8		150	
Storage temperature	T _{stg}		-55	150	°C
Junction temperature	T _{vj}		-40	150	°C

^[1] ISO 7637 test pulses are applied to V_{BAT} via a reverse polarity diode and >1uF blocking capacitor .

^[2] ISO 7637 test pulses are applied to CANH via a coupling capacitance of 1 nF.

^[3] The application board shall be realized with a ground copper foil area >150mm² (low conductance board in accordance to JEDEC51-7)

2.3 Static Characteristics

Unless otherwise specified all values in the following tables are valid for $V_{BAT} = 5V$ to $26.5V$ and $T_{AMB} = -40^{\circ}C$ to $125^{\circ}C$. All voltages are referenced to ground (GND), positive currents flow into the IC.

Parameter	Symbol	Condition	Min	Typ	Max	Unit
PIN VBAT						
Operating supply voltage	V_{BAT}		6	12	18	V
Low battery operating supply voltage	V_{BAT_L}	except high-speed/sleep mode	5		6	V
Short duration Operating supply voltage	V_{BAT_JS}	$T < 1min, T_{amb} < 85^{\circ}C$ (except high-speed mode)	18		26.5	V
Under-voltage lock-out	V_{BATuv}		4.0		4.8	V
Supply current, recessive, all active modes	I_{BAT}	$V_{BAT} = 18V, TxD$ open		5	8	mA
Normal mode supply current, dominant	$I_{BATN}^{[2]}$	$V_{BAT} = 26.5V$ $MODE0=MODE1=H, TxD=L,$ $R_{load} = 200\Omega$		30	35	mA
High-speed mode supply current, dominant	$I_{BATH}^{[2]}$	$V_{BAT} = 16V$ $MODE0=H, MODE1=L, TxD=L,$ $R_{load} = 75\Omega$		60	75	mA
Wake-up mode supply current, dominant	$I_{BATW}^{[2]}$	$V_{BAT} = 26.5V$ $MODE0=L, MODE1=H, TxD=L,$ $R_{load} = 200\Omega$		60	75	mA
Sleep mode supply current	I_{BATS}	$V_{BAT} = 13V, T_{amb} < 85^{\circ}C$		40	60	μA
PIN CANH						
Bus output voltage, low battery	V_{oh_l}	$R_L > 200\Omega,$ Normal, high-speed mode, $5V < V_{BAT} < 6V$	3.4		5.1	V
Bus output voltage	V_{oh}	$R_L > 200\Omega,$ Normal mode, $6V < V_{BAT} < 26.5V$	4.4		5.1	V
Bus output voltage, high-speed mode	V_{oh}	$R_L > 75\Omega,$ high-speed mode, $8V < V_{BAT} < 16V$	4.2		5.1	V
Fixed Wake-up Output High Voltage	$V_{ohWuFix}$	Wake-up mode, $R_L > 200\Omega,$ $11.2V < V_{BAT} < 26.5V$	9.9		12.5	V
Offset Wake-up Output High Voltage	$V_{ohWuOffset}$	Wake-up mode, $R_L > 200\Omega,$ $5V < V_{BAT} < 11.2V$	$V_{BAT} - 1.5$		V_{BAT}	V
Recessive state output voltage	V_{ol}	Recessive state or sleep mode, $R_{load} = 6.5 k\Omega,$	-0.2		0.20	V
Bus short circuit current	$-I_{CAN_SHORT}$	$V_{CANH} = 0V, V_{BAT} = 26.5V,$ $TxD = 0V$	50		350	mA
Bus leakage current during loss of ground	$I_{LKN_CAN}^{[1]}$	Loss of ground, $V_{CANH} = 0V$	-50		10	μA
Bus leakage current, bus positive	I_{LKP_CAN}	TxD high;	-10		10	μA
Bus input threshold	V_{ih}	Normal, high-speed mode	2.0	2.1	2.2	V
Bus input threshold low battery	V_{ihb}	Normal mode $5V < V_{BAT} < 6V$	1.6	1.7	2.2	V
Fixed Wake-up Input High Voltage Threshold	$V_{ihWuFix}^{[2]}$	Sleep mode, $V_{BAT} > 11.2V$	6.6		7.9	V

Parameter	Symbol	Condition	Min	Typ	Max	Unit
Offset Wake-up Input High Voltage Threshold	$V_{ihWuOffset}^{[2]}$	Sleep mode	$V_{BAT}-4.3$		$V_{BAT}-3.25$	V
PIN LOAD						
Voltage on switched ground pin	V_{LOAD}	$I_{LOAD} = 1\text{mA}$, all active modes and sleep mode			0.1	V
Voltage on switched ground pin	V_{LOAD_LOB}	$I_{LOAD} = 7\text{mA}$, $V_{BAT} = 0\text{V}$			1	V
Load resistance during loss of battery	R_{LOAD_LOB}	$V_{BAT} = 0$	R_{LOAD} -10%		R_{LOAD} +35%	Ω
PIN TXD,MODE0,MODE1						
High level input voltage	V_{ih}		2.0			V
Low level input voltage	V_{il}				0.65	V
TxD pull-up current	$-I_{il_TXD}$	TxD = L, MODE0 and 1 = H	20		50	μA
MODE pull-down resistor	R_{MODE_pd}		20		50	$\text{k}\Omega$
PIN RXD						
Low level output voltage	V_{ol_rxd}	$I_{RXD} = 2\text{mA}$			0.4	V
High level output leakage	I_{ih_rxd}	$V_{RXD} = 5\text{V}$	-10		10	μA
RxD output current	I_{rxd}	$V_{RXD} = 5\text{V}$			70	mA
PIN INH						
High level output voltage	V_{oh_INH}	$I_{INH} = -180\mu\text{A}$	$V_S-0.8\text{V}$	$V_S-0.5\text{V}$		V
Leakage current	I_{INH_lk}	Mode0/1 = L, $V_{INH} = 0\text{V}$	-5		5	μA
Over-temperature Protection						
Thermal shutdown	$T_{sd}^{[2]}$		155		180	$^{\circ}\text{C}$
Thermal recovery	$T_{rec}^{[2]}$		126		150	$^{\circ}\text{C}$

^[1] Leakage current in case of loss of ground is the sum of both currents I_{LKN_CAN} and I_{LKN_LOAD} .

^[2] Thresholds are not tested in production, but characterized and guaranteed by design

2.4 Dynamic Characteristics

Unless otherwise specified all values in the following table are valid for $V_{BAT} = 5V$ to $26.5V$ and $T_{AMB} = -40^{\circ}C$ to $125^{\circ}C$.

Parameter	Symbol	Condition	Min	Typ	Max	Unit
Transmit delay in normal and wake-up mode, rising edge	t_{Tr} [1]	min and max loads acc. To 2.5 Bus loading requirements	2		6.3	μs
Transmit delay in wake-up mode to V_{inWU} , rising edge	t_{TWUr} [2]	min and max loads acc. To 2.5 Bus loading requirements	3		18	μs
Transmit delay in normal mode, falling edge	t_{Tf} [3]	min and max loads acc. To 2.5 Bus loading requirements	1.8		10	μs
Transmit delay in wake-up mode, falling edge	t_{TWUf} [3]	min and max loads acc. To 2.5 Bus loading requirements	3		13.7	μs
Transmit delay in high-speed mode, rising edge	t_{THSr} [4]	min and max loads acc. To 2.5 Bus loading requirements	0.1		1.5	μs
Transmit delay in high-speed mode, falling edge	t_{THSf} [5]	min and max loads acc. To 2.5 Bus loading requirements	0.04		3	μs
Receive delay , all active modes	t_{DR} [6]	CANH high to low transition	0.2		1	μs
Receive delay , all active modes	t_{RD} [6]	CANH low to high transition	0.2		1	μs
Input minimum pulse length, all active modes	t_{mpDR} [6]	CANH high to low transition	0.1		1	μs
Input minimum pulse length, all active modes	t_{mpRD} [6]	CANH low to high transition	0.1		1	μs
Wake-up filter time delay	t_{WUF}	See diagrams, Figure 3	10		70	μs
Receive blanking time after TxD L-H transition	t_{rb}	See diagrams, Figure 4	0.5		6	μs
TxD time-out reaction time	t_{tout}	All active modes	10		30	ms
Delay from Normal to High-speed/HVWU Mode	t_{dnhs}				30	ms
Delay from High-speed /HVWU to Normal Mode	t_{dhsn}				30	ms
Delay from Normal Mode to Standby	t_{dsby}	$V_{BAT} = 6V$ to $26.5V$			500	μs
Delay from Standby to Sleep Mode	t_{dsleep}	$V_{BAT} = 6V$ to $26.5V$	100		500	ms
Delay from Sleep to normal Mode	t_{dsnwu}	$V_{BAT} = 6V$ to $26.5V$			50	ms

- [1] The maximum signal delay time for a bus rising edge is measured from $V_{\text{cmos_il}}$ on the TxD input pin to the $V_{\text{ihMax}} + V_{\text{g_off}}$ max level on CANH at maximum network time constant, minimum signal delay time for a bus rising edge is measured from $V_{\text{cmos_ih}}$ on the TxD input pin to 1V on CANH at minimum network time constant. These definitions are valid in both normal and HVWU mode
- [2] The maximum signal delay time for a bus rising edge in HVWU mode is measured from $V_{\text{cmos_il}}$ on the TxD input pin to the $V_{\text{ihWUMax}} + V_{\text{g_off}}$ max level on CANH at maximum network time constant, minimum signal delay time for a bus rising edge is measured from $V_{\text{cmos_ih}}$ on the TxD input pin to 1V on CANH at minimum network time constant
- [3] Maximum signal delay time for a bus falling edge is measured from $V_{\text{cmos_ih}}$ on the TxD input pin to 1V on CANH at maximum network time constant, minimum signal delay time for a bus falling edge is measured from $V_{\text{cmos_ih}}$ on the TxD input pin to the $V_{\text{ihMax}} + V_{\text{g_off}}$ max level on CANH. These definitions are valid in both normal and HVWU mode.
- [4] The signal delay time in high-speed mode for a bus rising edge is measured from $V_{\text{cmos_il}}$ on the TxD input pin to the $V_{\text{ihMax}} + V_{\text{g_off}}$ max level on CANH at maximum high-speed network time constant.
- [5] The signal delay time in high-speed mode for a bus falling edge is measured from $V_{\text{cmos_ih}}$ on the TxD input pin to 1V on CANH at maximum high-speed network time constant
- [6] Receive delay time is measured from the rising / falling edge crossing of the nominal V_{ih} value on CANH to the falling ($V_{\text{cmos_il_max}}$) / rising ($V_{\text{cmos_ih_min}}$) edge of RxD. This parameter is tested by applying a square wave signal to CANH. The minimum slew rate for the bus rising and falling edges is 50V/us. The low level on bus is always 0V. For normal mode and high-speed mode testing the high level on bus is 4V. For HVWU mode testing the high level on bus is $V_{\text{bat}} - 2V$.

2.5 Bus loading requirements

Parameter	Symbol	Min	Typ	Max	Unit
Number of system nodes		2		32	
Network distance between any two ECU nodes	Bus length			60	M
Node Series Inductor Resistance (if required)	R_{ind}			3.5	Ohm
Ground Offset Voltage	V_{goff}			1.3	V
Ground Offset Voltage, low battery	V_{gofflb}		0.1 V_{BAT}	0.6	V
Device Capacitance (unit load)	C_{ul}	135	150	300	pF
Network Total Capacitance	C_{tl}	396		19000	pF
Device Resistance (unit load)	R_{ul}	6435	6490	6665	Ohm
Device Resistance (min load)	R_{min}	2000			Ohm
Network Total Resistance	R_{tl}	200		3332	Ohm
High-Speed Mode Network Resistance to GND	R_{load}	75		135	Ohm
Network Time Constant [1]	τ	1		4	μs
Network Time Constant, high-speed mode [1]	τ			1.5	μs

[1] The network time constant incorporates the bus wiring capacitance. The minimum value is selected to limit radiated emissions. The maximum value is selected to ensure proper communication under all communication modes. Not all combinations of R and C are possible. The following load conditions are used for the measurement of the dynamic characteristics:

Normal and high volt. Wake-up mode	High-speed mode
min.load/min tau 3.3K Ω / 540pF	Additional 140 Ω tool resistance to

min.load/max tau	3.3K Ω / 1.2nF	ground in parallel
max.load/min tau	200 Ω / 5nF	Additional 120 Ω tool resistance to
max.load/max tau	200 Ω / 20nF	ground in parallel

2.6 Timing Diagrams

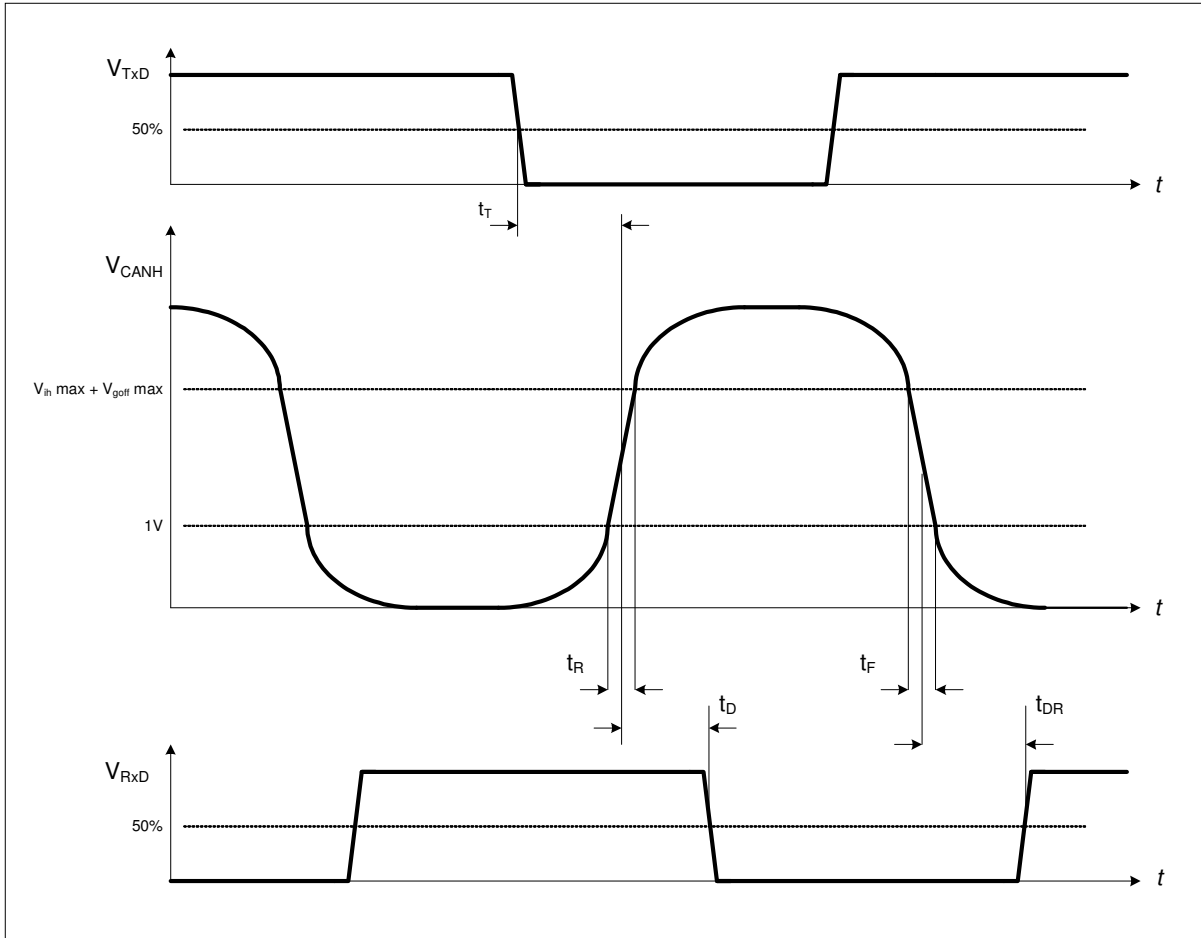

Figure 2 – Input / Output Timing

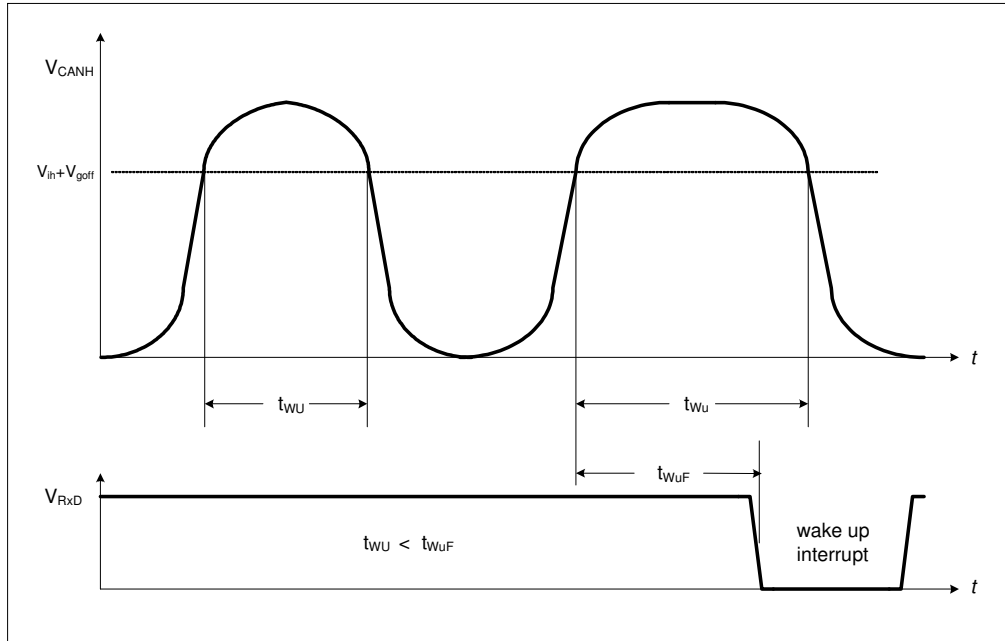

Figure 3 – Wake-up Filter Time Delay

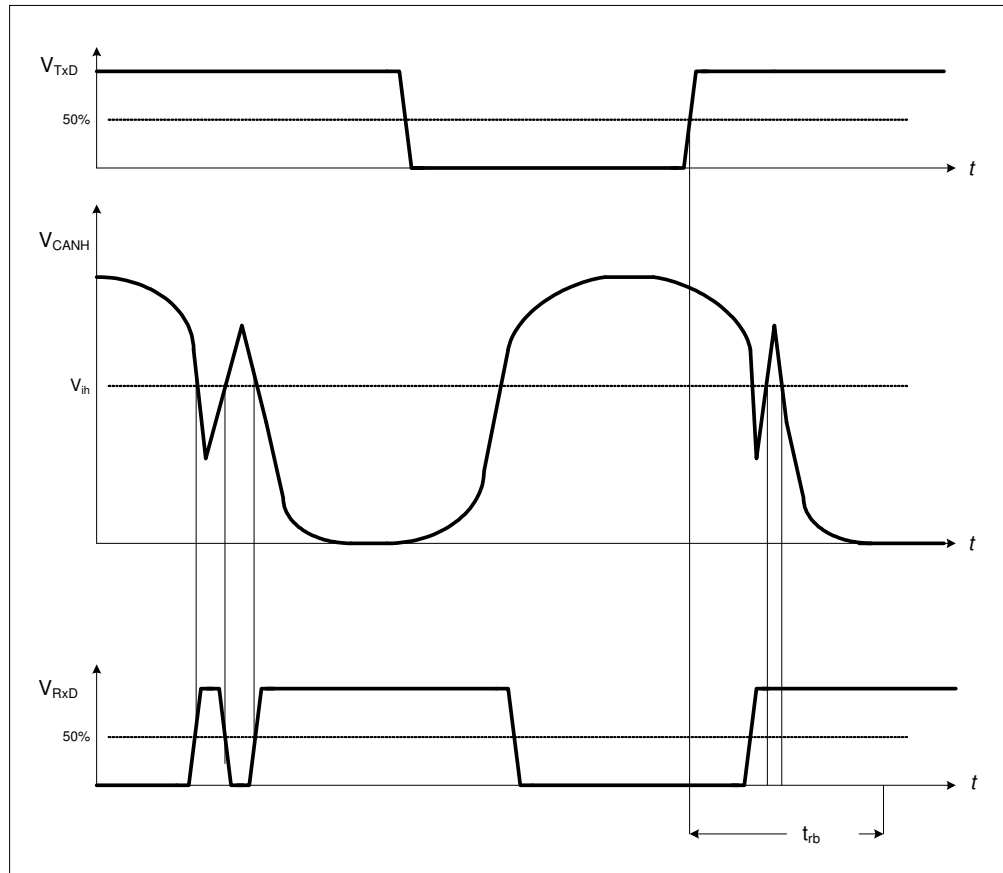

Figure 4 – Receive Blanking Time

3. Functional Description

3.1 TxD Input pin

Logic command to transmit on the single wire CAN bus

TxD Polarity

- TxD = logic 1 (or floating) on this pin produces an undriven or recessive bus state (low bus voltage)
- TxD = logic 0 on this pin produces either a bus normal or a bus high-voltage dominant state depending on the transceiver mode state (high bus voltage)

If the TxD pin is driven to a logic low state while Mode 0,1 pins are in the 0,0 or sleep state, the transceiver cannot drive the CAN Bus pin to the dominant state.

The transceiver provides an internal pull up on the TxD pin, which will cause the transmitter to default to the bus recessive state, when TxD is not driven.

TxD input signals are standard CMOS logic levels for 3.3V and 5V supply voltages.

Time-out feature

In case of a faulty blocked dominant TxD input signal the CANH output is switched off automatically after the specified TxD time-out reaction time to prevent a dominant bus. The transmission is continued by next TxD L to H transition without delay.

3.2 Mode 0 and Mode 1 pins

Select transceiver operating modes

The transceiver provides a weak internal pull-down current on each of these pins, which causes the transceiver to default to sleep mode when they are not driven. The Mode input signals are standard CMOS logic level for 3.3V and 5V supply voltages.

M0	M1	Mode
L	L	Sleep Mode
H	L	High-Speed
L	H	High-Voltage Wake-Up
H	H	Normal Mode

Figure 5 – Truth Table

Mode 0 = 0, Mode 1 = 0 – Sleep mode

Transceiver is in low-power state, waiting for wake-up via high-voltage signal or by mode pins change to any state other than 0,0. In this state, the CAN Bus pin is not in the dominant state regardless of the state of the TxD pin.

Mode 0 = 1, Mode 1 = 0 – High-Speed mode

This mode allows high-speed download with bitrates up to 100Kbit/s. The output waveshaping circuit is disabled in this mode. Bus transmitters which require communicating in high-speed mode are able to drive reduced bus resistance during this mode.

Note: High-speed mode is only allowed with connected tool resistance in parallel to the network load. Otherwise the stability of the output signal is not guaranteed because of the slew rate enhancement for the required rise times .

Mode 0 = 0, Mode 1 = 1 – Transmit with high voltage signals to wake up remote nodes (HVWU)

This bus includes a selective node awake capability, which allows normal communication to take place among some nodes while leaving the other nodes in an undisturbed sleep state. This is accomplished by controlling the signal voltages such that all nodes must wake up when they receive a higher voltage message signal waveform. The communication system communicates to the nodes information as to which nodes are to stay operational (awake) and which nodes are to put themselves into a non-communicating low-power “sleep” state. Communication at the lower, normal voltage levels does not disturb the sleeping nodes.

Mode 0 = 1, Mode 1 = 1 – Normal speed and signal voltage mode

Transmission bit rate in normal communication is 33.333 Kbits/sec. In normal transmission mode the TH8056 supports controlled waveform rise and overshoot times. Waveform trailing edge control is required to assure that high frequency components are minimized at the beginning of the downward voltage slope. The remaining fall time occurs after the bus is inactive with drivers off and is determined by the RC time constant of the total bus load.

3.3 RxD Output pin

Logic data as sensed on the single wire CAN bus

RxD polarity

RxD = logic 1 on this pin indicates a bus recessive state (low bus voltage)
RxD = logic 0 on this pin indicates a bus normal or high-voltage bus dominant state

RxD in Sleep Mode

RxD does not pass signals to the micro processor while in sleep mode until a valid wake-up bus voltage level is received or the Mode 0, 1 pins are not 0,0 respectively. When the valid wake-up bus signal awakens the transceiver, the RxD pin signalizes an interrupt (logic 0 for dominant high-voltage signal). If there is no mode change within the time stated, the transceiver reenters the sleep mode as described in 3.7

When not in sleep mode all valid bus signals will be sent out on the RxD pin.

RxD Typical Load

Resistance: 2.7 kohms
Capacitance: < 25 pF

3.4 Bus LOAD pin

Resistor ground with internal open-on-loss-of-ground protection

When the ECU experiences a loss of ground condition, this pin is switched to a high impedance state.

The ground connection through this pin is not interrupted in any transceiver operating mode including the sleep mode. The ground connection is interrupted only when there is a valid loss of ground condition.

This pin provides the bus load resistor with a path to ground which contributes less than 0.1 volts to the bus offset voltage when sinking the maximum current through one unit load resistor.

The transceiver's maximum bus leakage current contribution to V_{ol} from the LOAD pin when in a loss of ground state is 50 μ A over all operating temperatures and $3.5\text{ V} < V_{batt} < 26.5\text{V}$.

3.5 V_{bat} INPUT pin

Vehicle Battery Voltage

The transceiver is fully operational as described in chapter 2 over the range $6\text{V} < V_{bat\ IC} < 18\text{V}$ as measured between the GND pin and this pin.

For $5\text{V} < V_{bat\ IC} < 6\text{V}$ the bus operates in normal mode with reduced dominant output voltage and reduced receiver input voltage. High voltage wake-up call is not possible (dominant output voltage is the same as in normal or high-speed mode).

The transceiver operates in normal mode and high-voltage wake-up mode if $18\text{V} < V_{bat\ IC} < 26.5\text{V}$ at 85°C for one minute.

For $0\text{V} < V_{bat\ IC} < 4.8\text{V}$, the bus is passive (not driven dominantly) and RxD is undriven (high), regardless of the state of the TxD pin (under-voltage lock-out).

3.6 CAN BUS pin

Bus Input/Output

Wave Shaping in normal and HVWU mode

Wave shaping is incorporated into the transmitter to minimize EMI radiated emissions. An important contributor to emissions is the rise and fall times during output transitions at the "corners" of the voltage waveform. The resultant waveform is one half of a sine wave of frequency 50 – 65 kHz at the rising waveform edge and one quarter of this sine wave at falling or trailing edge.

Short circuits

If the CAN BUS pin is shorted to ground for any duration of time, the current is limited to the specified value, until an over-temperature shut-down circuit disables the output high side drive source transistor (before the local die temperature exceeds the damage limit threshold).

Loss of ground

In case of an ECU loss of ground condition, the LOAD pin is switched into high impedance state. The CANH transmission is continued until the under-voltage lock-out voltage threshold is detected.

Loss of battery

In case of battery loss ($V_{BAT} = 0$ or open) the transceiver does not disturb bus communication. The maximum reverse current into power supply system doesn't exceed $500\mu\text{A}$.

3.7 INH Pin (TH8056 KDC A only)

This Pin is a high-voltage highside switch used to control the ECU's regulated microcontroller voltage supply. After power-on the transceiver automatically enters an intermediate standby mode, the INH output will become HIGH (V_{BAT}) and therefore the external voltage regulator will provide the V_{cc} supply for the ECU .

If there is no mode change within the time stated, the transceiver reenters the sleep mode and the INH output goes to logic 0 (floating). When the transceiver has detected a valid wake-up condition (bus HVWU traffic which exceeds the wake-up filter time delay) the INH output will become HIGH (VBAT) again and the same procedure starts as described after power-on. In case of a mode change into any active mode the sleep timer is stopped and INH keeps high (VBAT) level. If the transceiver enters the sleep mode (M0,1=0), INH goes to logic 0 (floating) no sooner than 100ms when no wake-up signal is present.

3.8 State Diagram

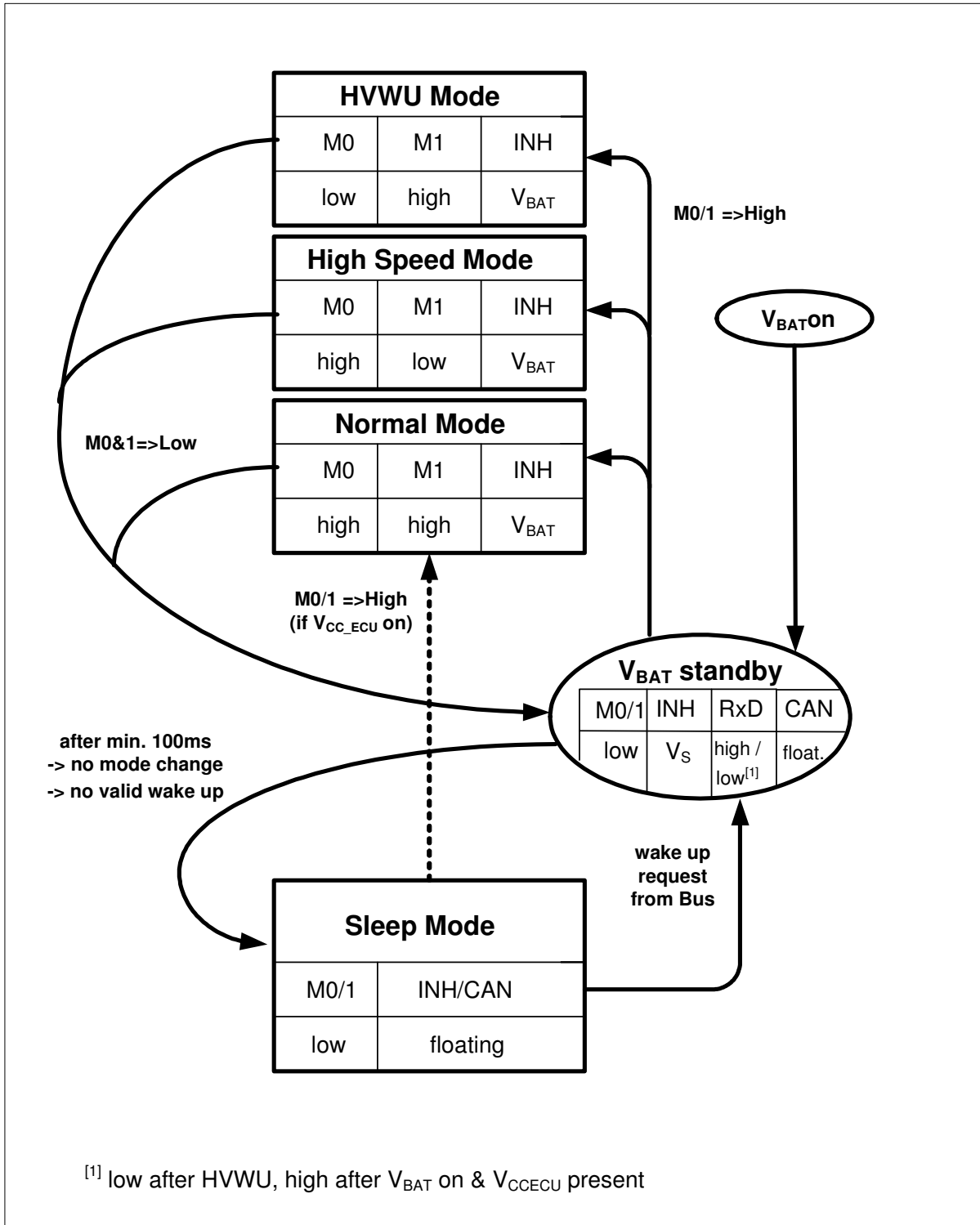

Figure 6 – State Diagram

3.9 Power Dissipation

The TH8056 has an integrated protection against thermal overload. If the junction temperature reaches the thermal shutdown threshold the TH8056 disables the transmitter driver to reduce the power dissipation to protect the IC itself from thermal overload. The function of the transceiver will become again available if the junction temperature drops below the thermal recovery temperature.

To secure a stable functioning within the application and to avoid a transmitter switch off due to thermal overload under normal operating conditions, the application must take care of the maximum power dissipation of the IC. The junction temperature can be calculated with:

$$T_J = T_a + P_d * \theta_{ja}$$

T_J	Junction temperature
T_a	Ambient temperature
P_d	Dissipated power
θ_{ja}	Thermal resistance

The Junction temperature shouldn't exceed under normal operating conditions the limit specified in chapter 2.3 Static Characteristics.

The power dissipation of an IC is the major factor determining the junction temperature. The TH8056 consumes current in different functions. A part of the supply current goes to the load and the other part dissipates internally. The internal part has a constant passive part and an active part which depends on the actual bus transmission. The complete internal part causes and increasing of the junction temperature.

$$P_{tot} = P_{INT_a} + P_{INT_p}$$

P_{INT_a}	Internal power dissipation active
P_{INT_p}	Internal power dissipation passive
P_{tot}	Overall power dissipation
D	Duty cycle for data transmission

The internal passive part can be calculated with the operating voltage and the normal mode supply current recessive. The active part can be calculated with the voltage drop of the driving transistor and the current of the CAN bus. The active part generates only during data transmission power dissipation. Therefore the duty cycle has to be taken into account.

$$P_{INT_p} = V_{BAT} * I_{BAT}$$

$$P_{INT_a} = (V_{BAT} - V_{CANH}) * I_{load} * D$$

V_{BAT}	Battery supply voltage
I_{BAT}	Normal mode supply current recessive
I_{load}	Can network current
D	Duty cycle for data transmission
V_{CANH}	Voltage at CANH pin

The power dissipation of the load can be calculated with the CANH voltage and the CAN bus current.

$$P_{load} = V_{CANH} * I_{load} * D$$

where

$$I_{load} = V_{CANH} / R_{load_net}$$

P_{load}	Power dissipation of the load resistor
I_{load}	Current of CAN network
V_{CANH}	Voltage at CANH pin
R_{load_net}	Network total resistance

Assumptions:

$V_{BAT} = 26.5V$
 $R_{load} = 6.49\text{ k}\Omega$
Network with 32 nodes
 $V_{CANH} = 5.1V$
 $I_{BAT} = 6mA$
 $D = 50\%$
 $T_a = 125^\circ C$
 $\Theta_{JA} = 70k/W$ (Thermally enhanced SOIC14 package)

Computations:

$R_{load_net} = 6.49k\Omega / 32nodes = 203\Omega$
 $I_{load} = 5.1V / 203\Omega = 25mA$
 $P_{load} = 5.1V * 25mA * 0.5 = 64mW$
 $P_{INT_a} = (26.5V - 5.1V) * 25mA * 0.5 = 267mW$
 $P_{INT_P} = 26.5V * 6mA = 159mW$
 $P_{tot} = 267mW + 159mW = 426mW$
 $T_j = 125^\circ C + 426mW * 70k/W = 155^\circ C$

The above calculation shows that under worst case conditions (max. operating voltage, max bus load, max ambient temperature) the TH8056 with the thermally enhanced SOIC14 package operates below the thermal limit. A stable functioning is possible up to these limits.

3.9.1. Thermal behaviour of TH8056 with SOIC8 – TH8056 KDC A8

The thermal impedance of an SOIC8 package is about twice in comparison to the thermally enhanced SOIC14 package. Therefore the maximum power dissipation within this package is only about the half.

The using of the SOIC8 version of TH8056 depends on the network architecture (number of nodes), the max. ambient temperature and the needed functionality (using of INH pin).

The following diagram shows the relationship between junction temperature, ambient temperature and number of nodes, which have to be taken into account for using the SOIC8 version.

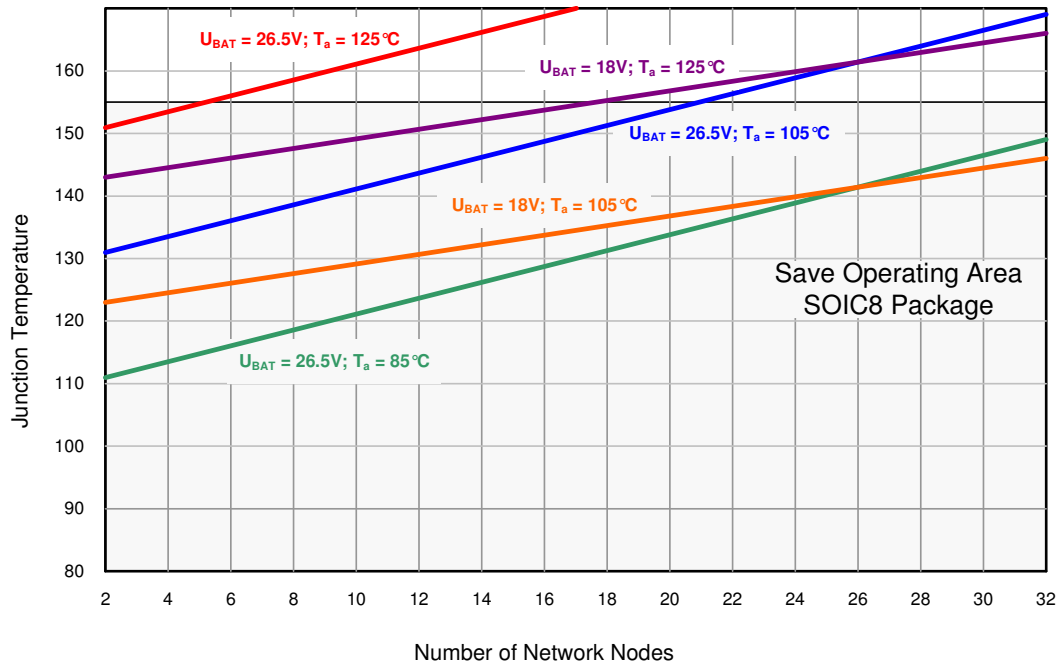

Figure 7 – Save operating area of SOIC8 package

3.10 Application Circuitry

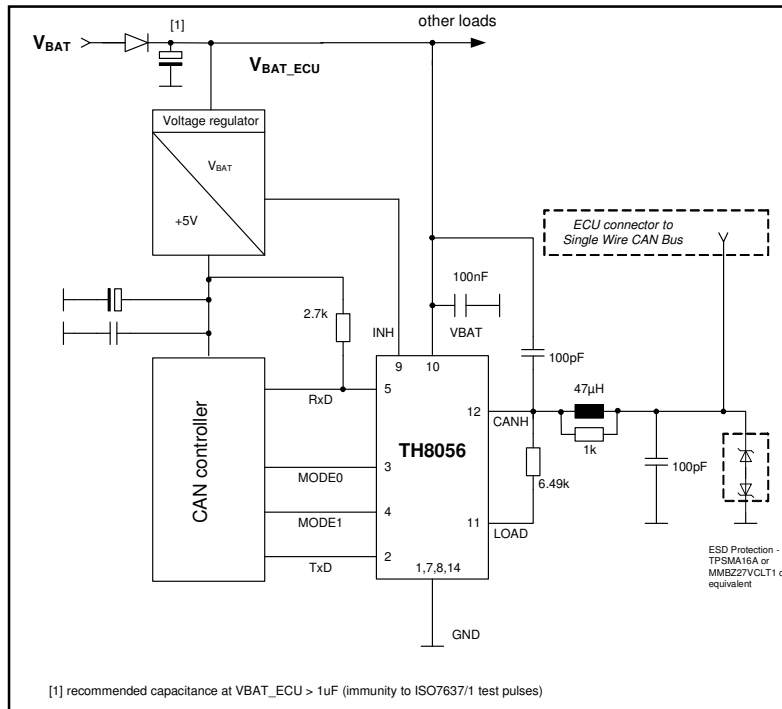

Figure 8 – Application Circuitry TH8056 KDC A

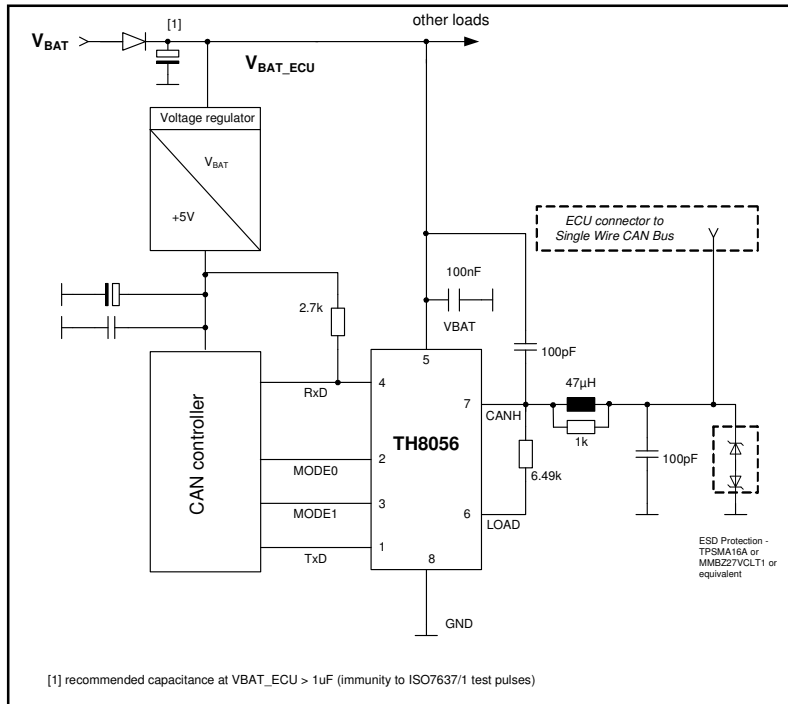
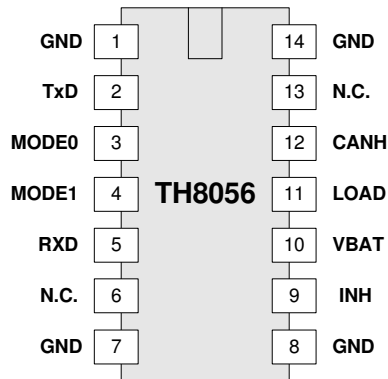

Figure 9 – Application circuitry TH8056 KDC A8

4. Pin Description

TH8056 KDC A



TH8056 KDC A8

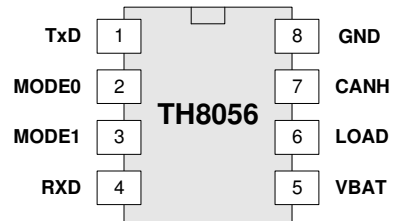

Pin TH8056 KDC A	Pin TH8056 KDC A8	Name	IO-Typ	Description
1	-	GND	P	Ground
2	1	TXD	I	Transmit data from MCU to CAN
3	2	MODE0	I	Operating mode select input 0
4	3	MODE1	I	Operating mode select input 1
5	4	RXD	O	Receive data from CAN to MCU
6	-	N.C.		
7	-	GND	P	Ground
8	-	GND	P	Ground
9	-	INH	O	Control Pin for external voltage regulator (high voltage high side switch)
10	5	VBAT	P	Battery voltage
11	6	LOAD	O	Resistor load (loss of ground low side switch)
12	7	CANH	I/O	Single wire CAN bus pin
13	-	N.C.		
14	8	GND	P	Ground

5. Package Dimensions

5.1 SOIC14

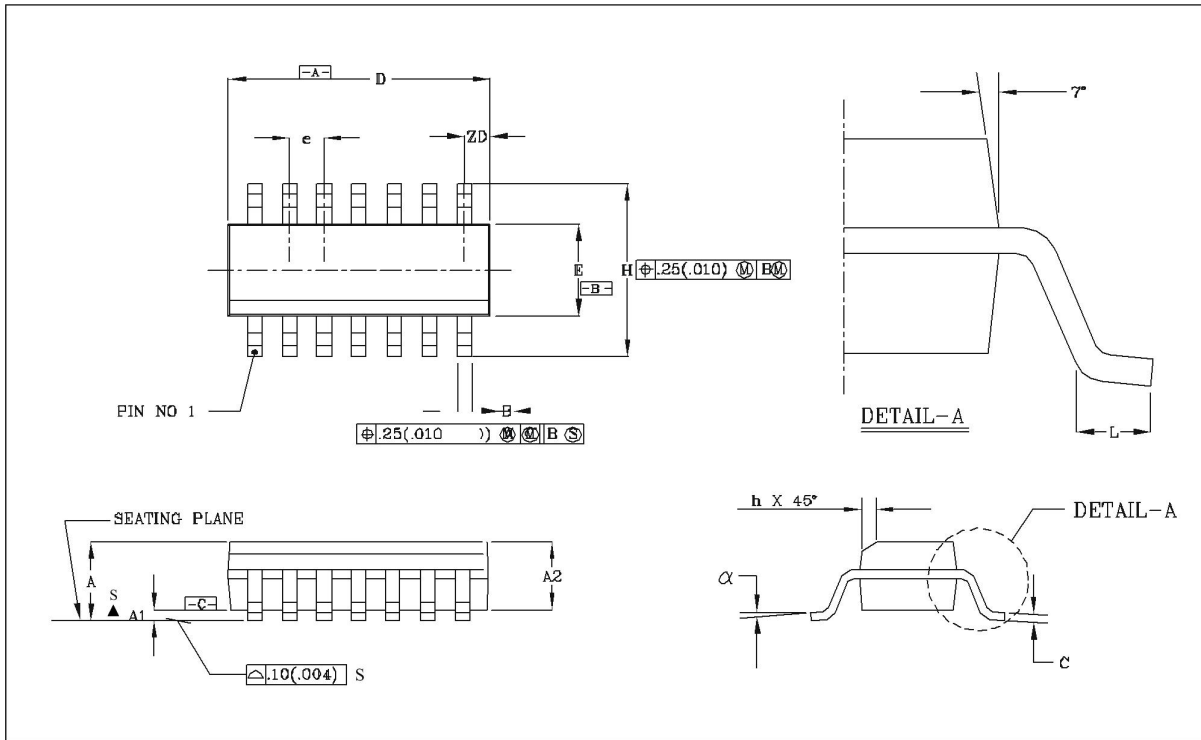

Small Outline Integrated Circuit (SOIC), SOIC 14, 150 mil

	A1	B	C	D	E	e	H	h	L	A	α	ZD	A2
All Dimension in mm, coplanarity < 0.1 mm													
min	0.10	0.36	0.19	8.56	3.81	1.27	5.80	0.25	0.41	1.52	0°	0.51	1.37
max	0.25	0.45	0.25	8.74	3.99		6.20	0.50	1.27	1.72	8°		1.57
All Dimension in inch, coplanarity < 0.004"													
min	0.004	0.014	0.0075	0.337	0.160	0.050	0.228	0.010	0.016	0.060	0°	0.020	0.054
max	0.01	0.018	0.0098	0.344	0.167		0.244	0.020	0.050	0.068	8°		0.062

5.2 SOIC8

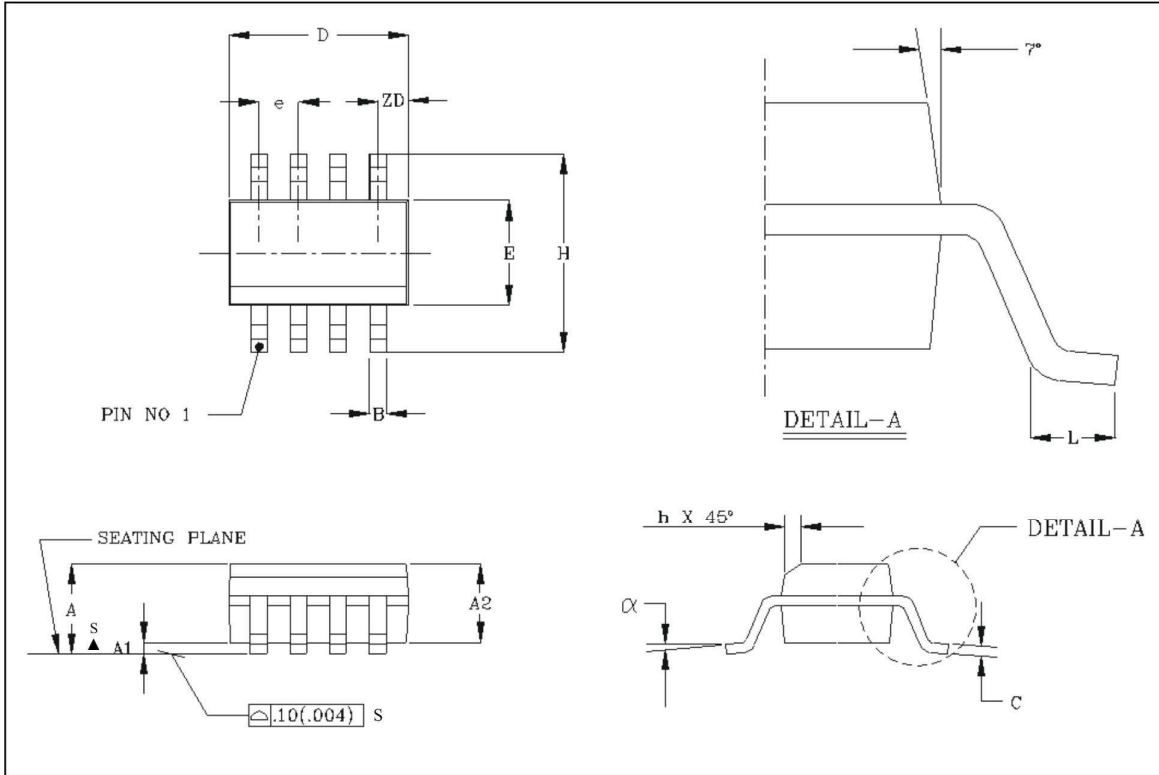

Small Outline Integrated Circuit (SOIC), SOIC 8, 150 mil

	A1	B	C	D	E	e	H	h	L	A	α	ZD	A2
All Dimension in mm, coplanarity < 0.1 mm													
min	0.10	0.36	0.19	4.80	3.81	1.27	5.80	0.25	0.41	1.52	0°	0.53	1.37
max	0.25	0.46	0.25	4.98	3.99		6.20	0.50	1.27	1.72	8°		1.57
All Dimension in inch, coplanarity < 0.004"													
min	0.004	0.014	0.0075	0.189	0.150	0.050	0.2284	0.0099	0.016	0.060	0°	0.021	0.054
max	0.0098	0.018	0.0098	0.196	0.157		0.244	0.0198	0.050	0.068	8°		0.062

6. Tape and Reel Specification

6.1 Tape Specification

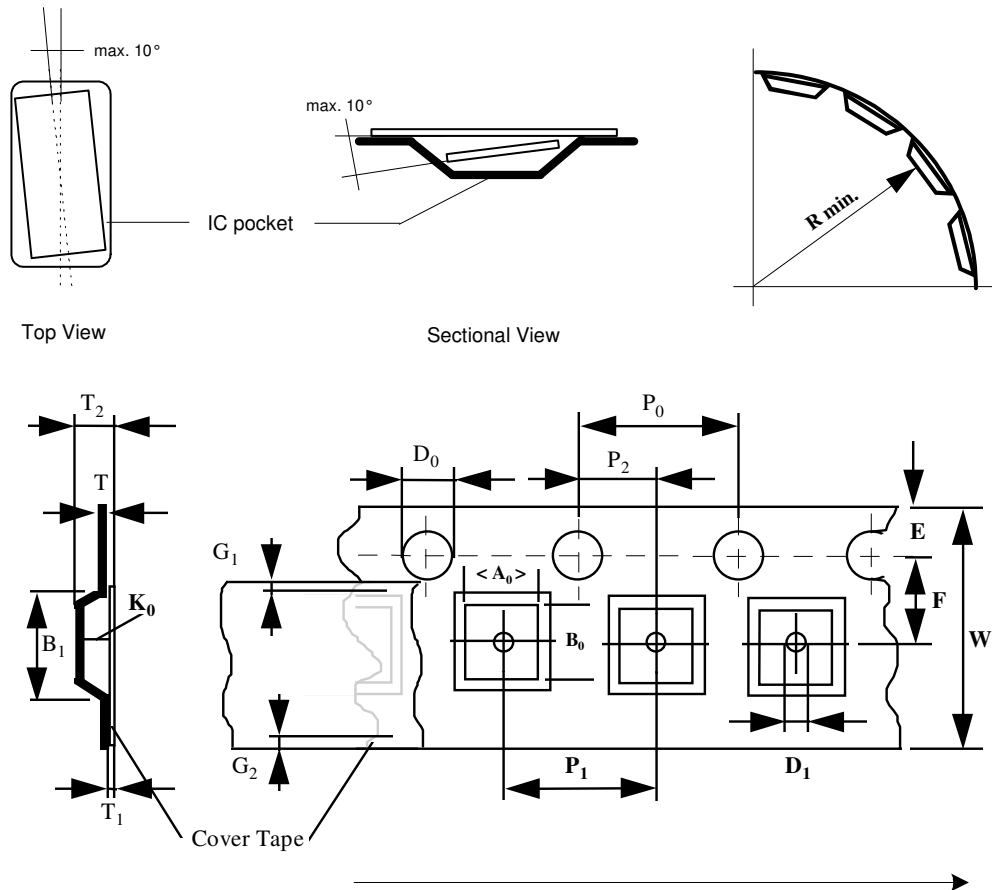

Standard Reel with diameter of 13"

Package	Parts per Reel	Width	Pitch
SOIC14	3000	16 mm	8 mm
SOIC8	3000	12 mm	8 mm

D_0	E	P_0	P_2	T_{max}	T_1_{max}	G_1_{min}	G_2_{min}	B_1_{max}	D_1_{min}	F	P_1	R_{min}	T_2_{max}	W
SOIC14														
1.5 +0.1	1.75 ±0.1	4.0 ±0.1	2.0 ±0.1	0.6	0.1	0.75	0.75	12.1	1.5	7.5 ±0.1	4 – 12 ±0.1	30	8.0	16.0 ±0.3
SOIC8														
1.5 +0.1	1.75 ±0.1	4.0 ±0.1	2.0 ±0.1	0.6	0.1	0.75	0.75	8.2	1.5	5.5 ±0.05	4 ±0.1	30	6.5	12.0 ±0.3

A_0 , B_0 , K_0 can be calculated with package specification. Cover Tape width 13.3 mm.

6.2 Reel Specification for SOIC14NB

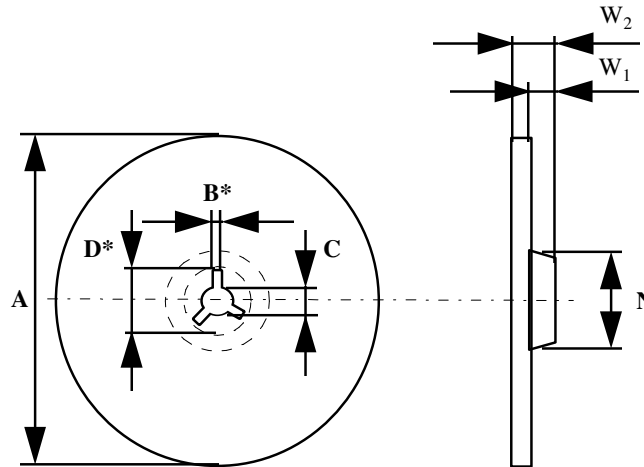

A_{max}	B^*	C	D^*_{min}
330	2.0 ± 0.5	$13.0 +0,5/-0,2$	20.2

Width of half reel	N_{min}	W_1	$W_{2_{max}}$
4 mm	100.0	4.4	7.1
8 mm	100.0	8.4	11.1

7. ESD/EMC Remarks

7.1 General Remarks

Electronic semiconductor products are sensitive to Electro Static Discharge (ESD). Always observe Electro Static Discharge control procedures whenever handling semiconductor products.

7.2 ESD-Test

The TH8056 is tested according to MIL883D (human body model).

7.3 EMC

The test on EMC impacts is done according to ISO 7637-1 for power supply pins and ISO 7637-3 for data- and signal pins.

Power Supply pin VBAT, CANH, LOAD:

Testpulse	Condition	Duration
1	$t_r = 5 \text{ s} / U_S = -100 \text{ V} / t_D = 2 \text{ ms}$	5000 pulses
2	$t_r = 0.5 \text{ s} / U_S = 100 \text{ V} / t_D = 0.05 \text{ ms}$	5000 pulses
3a/b	$U_S = -200 \text{ V} / U_S = 200 \text{ V}$ burst 100ns / 10 ms / 90 ms break	1h
5	$R_i = 0.5 \Omega, t_D = 400 \text{ ms}$ $t_r = 0.1 \text{ ms} / U_P + U_S = 40 \text{ V}$	10 pulses every 1min

7.4 Latch Up Test

The TH8056 is tested according to JESD78 (Class 2).

8. Revision History

Version	Changes	Remark	Date
001		Initial Release	Sep. 2002
001a	<ul style="list-style-type: none"> - Added chapter revision history - Error corrected within Figure 1 - Block Diagram 		March 2003
002	<ul style="list-style-type: none"> - Pinout corrected within Figure 8 – Application Circuitry 		06/13/03
003	<ul style="list-style-type: none"> - compatibility to GMW3089 Version 2.2 - Static Characteristics modified according to GMW3089 V2.2 - Dynamic Characteristics modified according to GMW3089 V2.2 - Bus loading requirements modified according to GMW3089 V2.2 - High-speed Mode added remark - V_{BAT} input pin description changed - Add Tape and Reel Specification - Change of ESD/EMC Remarks 		09/18/03
004	<ul style="list-style-type: none"> - Changed application circuitry according to GMW3089 Rev.2.2 		12/01/03
005	<ul style="list-style-type: none"> - Change of chapter 9. Assembly Information 		05/13/04
006	<ul style="list-style-type: none"> - Change of Order Code 		06/14/04
007	<ul style="list-style-type: none"> - Update of chapter “Features” with compatibility to GMW3089 V2.3 and very low leakage current during loss of ground - Update of chapter “Features” high voltage wake up mode instead of high speed .. - Change of “Static characteristics” <ul style="list-style-type: none"> o Supply current dominant o Transmit delay - Change of “Dynamic characteristics” <ul style="list-style-type: none"> o Input min pulse length o Condition for mode change from normal to standby, standby to sleep and sleep to normal - Change of application circuitry acc. To GMW3089 V2.3 Spec. 		24/06/04
008	<ul style="list-style-type: none"> - Change of “Static characteristics” <ul style="list-style-type: none"> o Offset Wake-up Output High Voltage o Mode pull down resistor 		31/08/04
009	<ul style="list-style-type: none"> - Additional Package Version SOIC8 - Additional chapter “Power Dissipation” 		15/04/05
010	<ul style="list-style-type: none"> - Adaption of sleep mode condition acc. To GMW3089 Rev. 2.4 - Change of ESD capability of CANH pin - Update of Assembly information 		21/03/06
011	<ul style="list-style-type: none"> - Change of Parameter “Input minimum pulse length at CANH” - Change of “Short duration operating supply voltage” - Change of “Receive Delay” - Change of “Low level input voltage” at TxD, Mode 0,1 		08/12/06

Version	Changes	Remark	Date
012	- Change of load pin definition to be compliant to GMW3089 2.4		07/03/07
013	- Change of chapter 6.1 Tape Specification <ul style="list-style-type: none">o Number of parts per reel		09/11/10
014	- Logo, disclaimer, information regarding solderability, ordering code		14/june/12

9. **Standard information regarding manufacturability of Melexis products with different soldering processes**

Our products are classified and qualified regarding soldering technology, solderability and moisture sensitivity level according to following test methods:

Reflow Soldering SMD's (Surface Mount Devices)

- IPC/JEDEC J-STD-020
Moisture/Reflow Sensitivity Classification for Nonhermetic Solid State Surface Mount Devices (classification reflow profiles according to table 5-2)
- EIA/JEDEC JESD22-A113
Preconditioning of Nonhermetic Surface Mount Devices Prior to Reliability Testing (reflow profiles according to table 2)

Wave Soldering SMD's (Surface Mount Devices) and THD's (Through Hole Devices)

- EN60749-20
Resistance of plastic- encapsulated SMD's to combined effect of moisture and soldering heat
- EIA/JEDEC JESD22-B106 and EN60749-15
Resistance to soldering temperature for through-hole mounted devices

Iron Soldering THD's (Through Hole Devices)

- EN60749-15
Resistance to soldering temperature for through-hole mounted devices

Solderability SMD's (Surface Mount Devices) and THD's (Through Hole Devices)

- EIA/JEDEC JESD22-B102 and EN60749-21
Solderability

For all soldering technologies deviating from above mentioned standard conditions (regarding peak temperature, temperature gradient, temperature profile etc) additional classification and qualification tests have to be agreed upon with Melexis.

The application of Wave Soldering for SMD's is allowed only after consulting Melexis regarding assurance of adhesive strength between device and board.

Melexis is contributing to global environmental conservation by promoting **lead free** solutions. For more information on qualifications of **RoHS** compliant products (RoHS = European directive on the Restriction Of the use of certain Hazardous Substances) please visit the quality page on our website:

<http://www.melexis.com/quality.aspx>

10. Disclaimer

Devices sold by Melexis are covered by the warranty and patent indemnification provisions appearing in its Term of Sale. Melexis makes no warranty, express, statutory, implied, or by description regarding the information set forth herein or regarding the freedom of the described devices from patent infringement. Melexis reserves the right to change specifications and prices at any time and without notice. Therefore, prior to designing this product into a system, it is necessary to check with Melexis for current information. This product is intended for use in normal commercial applications. Applications requiring extended temperature range, unusual environmental requirements, or high reliability applications, such as military, medical life-support or life-sustaining equipment are specifically not recommended without additional processing by Melexis for each application.

The information furnished by Melexis is believed to be correct and accurate. However, Melexis shall not be liable to recipient or any third party for any damages, including but not limited to personal injury, property damage, loss of profits, loss of use, interrupt of business or indirect, special incidental or consequential damages, of any kind, in connection with or arising out of the furnishing, performance or use of the technical data herein. No obligation or liability to recipient or any third party shall arise or flow out of Melexis' rendering of technical or other services.

© 2012 Melexis NV. All rights reserved.

For the latest version of this document, go to our website at
www.melexis.com

Or for additional information contact Melexis Direct:

Europe, Africa, Asia:	America:
Phone: +32 1367 0495	Phone: +1 248 306 5400
E-mail: sales_europe@melexis.com	E-mail: sales_usa@melexis.com

ISO/TS 16949 and ISO14001 Certified