



Features and Benefits

- Converts light intensity to voltage
- High linearity
- Low temperature dependency
- Supply voltage range 3V to 5.5V
- Open drain output voltage output
- Standard DFN3x3 or SO8 package
- Designed for automotive applications
- Solder reflow 260degC, MSL3
- Automotive qualified AEC-Q100 Grade 1
- Operating temperature -40 up to 125degC
- RoHS compliant lead-free

Applications

General

- Ambient Light Sensor
- LCD Backlight Sensor
- LED Light Sensor
 - LED monitoring
 - Closed loop control for LED light intensity & LED color

Automotive

- Automatic light dimming of instrument panels and displays
- Headlights on/off control
- Hand presence detection for opening doors
- Sunload Sensor

Printers/Copiers

- Paper feed detection
- Paper size and orientation detection
- Toner cartridge presence detection

Ordering Information

Part No.	Temperature Code	Package Code	Option Code	Delivery Form
MLX75305	S -20°C to 85°C	XD SO8 Open Cavity	A: Responsivity Gain10 B: Responsivity Gain1	Tape On Reel
MLX75305	S -20°C to 85°C	XE DFN3x3 Open Cavity	A: Responsivity Gain10 B: Responsivity Gain1	Tape On Reel
MLX75305	K -40°C to 125°C	XD SO8 Open Cavity	A: Responsivity Gain10 B: Responsivity Gain1	Tape On Reel
MLX75305	K -40°C to 125°C	XE DFN3x3 Open Cavity	A: Responsivity Gain10 B: Responsivity Gain1	Tape On Reel



1 Functional Diagram

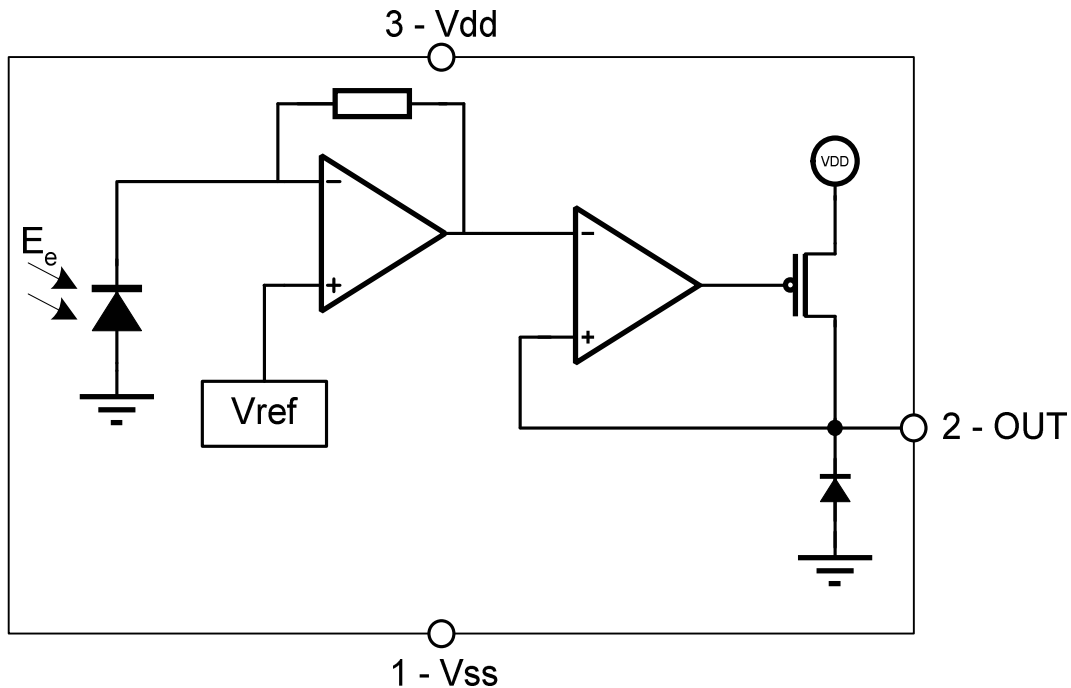

2 General Description

The Melexis SensorEyeC series are CMOS integrated optical sensor ICs including photodiode, transimpedance amplifier and output transistor on one chip. These sensors are designed for high-volume automotive and non-automotive applications.

The MLX75305 Light-to-Voltage SensorEyeC converts ambient or LED light intensity into an output voltage.

The MLX75305 block diagram is shown in Section 1 and contains following blocks: a photodiode, a transimpedance amplifier to convert and amplify the photocurrent of the photodiode and an open drain output buffer stage.



Table of Contents

1 Functional Diagram.....2

2 General Description2

3 Pin Definitions and Descriptions SO8.....4

4 Pin Definitions and Descriptions DFN3x3.....4

5 Absolute Maximum Ratings4

6 MLX75305 Specifications5

7 Spectral Responsivity.....6

8 Timing diagrams6

9 Applications Information.....7

10 SO8 Open Cavity Package Information.....8

11 DFN3x3 Open Cavity Package Information.....9

12 Standard information regarding manufacturability of Melexis products with different soldering processes.....10

13 ESD Precautions10

14 Disclaimer.....11



3 Pin Definitions and Descriptions SO8

Pin Number	Pin Name	Description	Type
1	Vss	Ground connection	Ground
2	OUT	Analog output	Open drain output
3	Vdd	Power supply	Supply
4	Gain	Responsivity Gain 10/1 selector (engineering samples only) ¹	Input
5..8	N.C.	Not connected	Floating

4 Pin Definitions and Descriptions DFN3x3

Pin Number	Pin Name	Description	Type
1	Vss	Ground connection	Ground
2	OUT	Analog output	Open drain output
3	Vdd	Power supply	Supply
4	Gain	Responsivity Gain 10/1 selector (engineering samples only) ¹	Input
5	N.C.	Not connected	Floating
6..10	N.C.	Not connected	Floating

5 Absolute Maximum Ratings

Valid for all MLX75305 versions. All voltages are referenced to Vss.

Symbol	Rating	Value	Unit
Vdd	Supply Voltage, V _{DD} (over voltage)	-0.3 to 7	V
V _{out}	DC Output Voltage	-0.3 to Vdd+0.3	V
I _{out}	DC Output Current, per Pin	±20	mA
T _{Stg}	Storage Temperature Range, T _S	-40 to 125	°C
V _{ESD-HBM}	ESD Sensitivity (Human Body Model according to CDF-AEC-Q100)	4	kV
V _{ESD-MM}	ESD Sensitivity (Machine Model according to CDF-AEC-Q100)	200	V

Exceeding the absolute maximum ratings may cause permanent damage. Exposure to absolute-maximum-rated conditions for extended periods may affect device reliability.

¹ The 'Gain' pin is only available on engineering samples. Leaving this pin unconnected selects the Responsivity Gain10 mode. Connecting this pin to Vss selects the Responsivity Gain1 mode.



6 MLX75305 Specifications

All voltages are referenced to Vss.

Symbol	Parameter	Conditions	Min	Typ	Max	Units	Test ¹
Vdd	Supply Voltage		3		5.5	V	V
Idd	Static Power Supply Current	At Vdd=5.5V, unloaded output			2	mA	V
Vdark	Dark level	(a), (c) Ee=0 T _{amb} =-40 .. 85°C T _{amb} =85 .. 125°C			160 210	mV mV	V V
Re10	Responsivity for devices with option code A (Gain10)	(a), Vout range = 50mV..4.5V, 25°C	-15%	70 (TDB)	+15%	mV/(μW/cm ²)	V
Re1	Responsivity for devices with option code B (Gain1)	(a), Vout range = 50mV..4.5V, 25°C	-15%	7 (TDB)	+15%	mV/(μW/cm ²)	V
NLAO	RMS Non Linearity	(a), in the 10..90% Output Range			+/-2	%	V
TC	Temperature Coefficient	(b), Ee=46μW/cm ² For visual light: For NIR (λ=850nm):		-0.16 0.06		%/C %/C	X X
λ _{0,3}	Spectral Bandwidth	T _{amb} =25°C	500		1000	nm	X
E _{max}	Absolute Maximum Irradiance	Vdd=5V, λ=850nm, T _{amb} =25°C		50*E _{vout}		μW/cm ²	X
S _{pd}	Area of photodiode			0.36		mm ²	D
V _{OH}	Maximum Output voltage high	(a), Ee=15*E _{vout} ...E _{max}	4.9	4.95		V	V
t _{Vdd_rise}	Vdd rise time	10..90% of Vdd		4		μs	V
t _{setup}	Electrical setup-time	(a), Vout within Vdd/2 +/- 5%		70	140	μs	V
t _{on}	Turn-on time	(a), Vout > V _{OH_min}		6	50	μs	V
t _{off}	Turn-off time	(a), Vout > V _{OH_min}		6	50	μs	V
t _r	Rise time	(a), Vout > V _{OH_min}		10	22	μs	V
t _f	Fall time	(a), Vout > V _{OH_min}		10	22	μs	V
T _A	Operating Temperature Range	Temperature Code S Temperature Code K	-20 -40		85 125	°C °C	V V

(a) Vdd=5V, R_L=10kOhm, C_L=50pF, λ= 850nm

(b) Vdd=5V, R_L=10kOhm, C_L=50pF

(c) The dark level is ratio metric with the Vdd power supply voltage

¹ The column *Test* indicates if the specific parameter is tested in production. Following symbols are used:

V: the specific parameter is tested in production

X: the specific parameter is verified in characterisation, but is not tested in production (e.g. timings and capacitances)

D: the specific parameter is guaranteed by design and is not tested as such in production



7 Spectral Responsivity

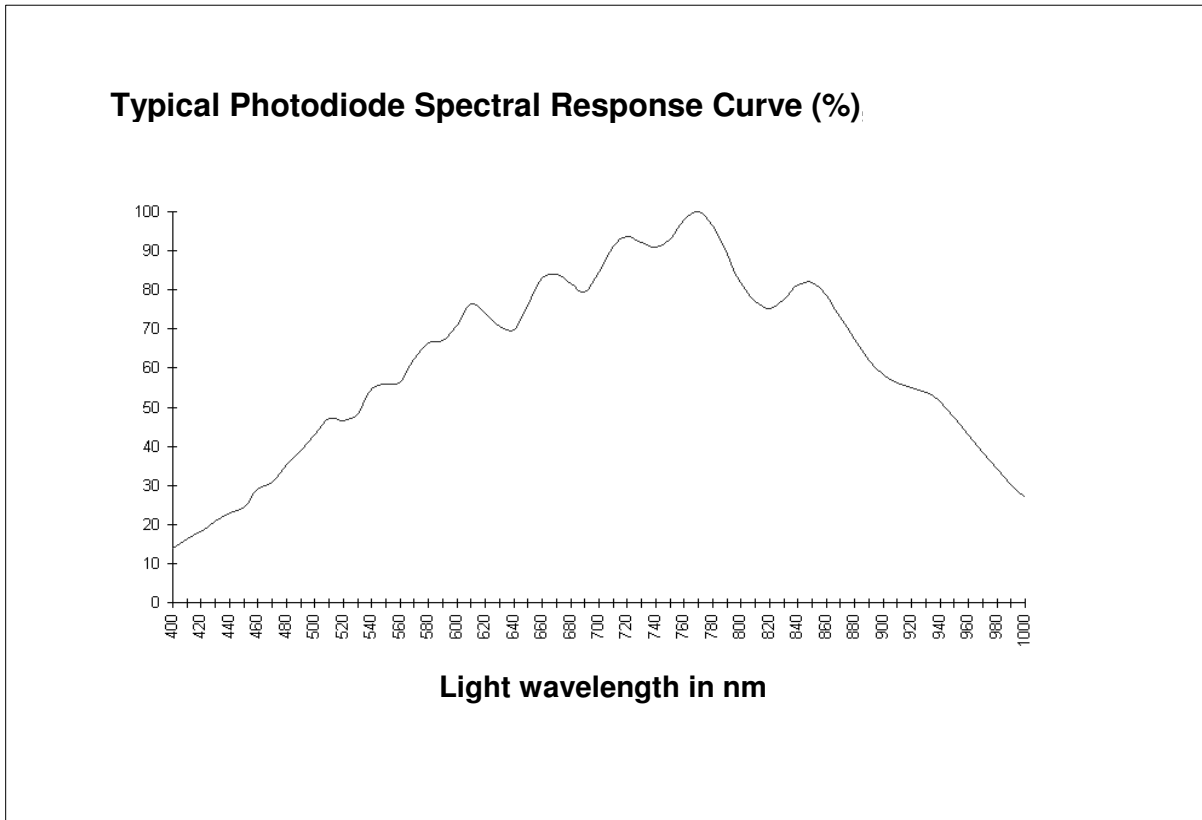

8 Timing diagrams

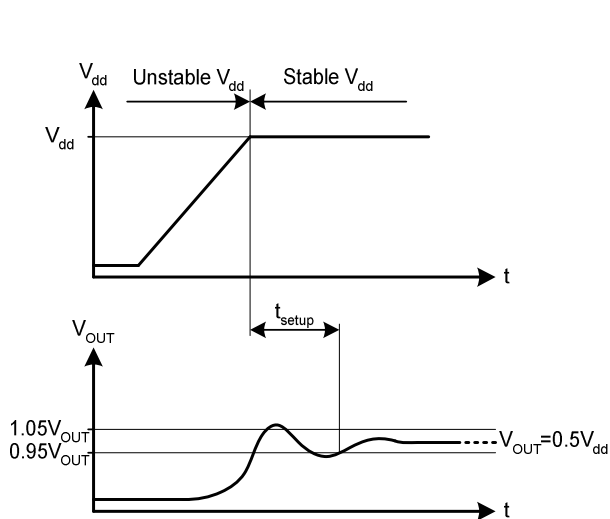

Definition of the electrical setup-time

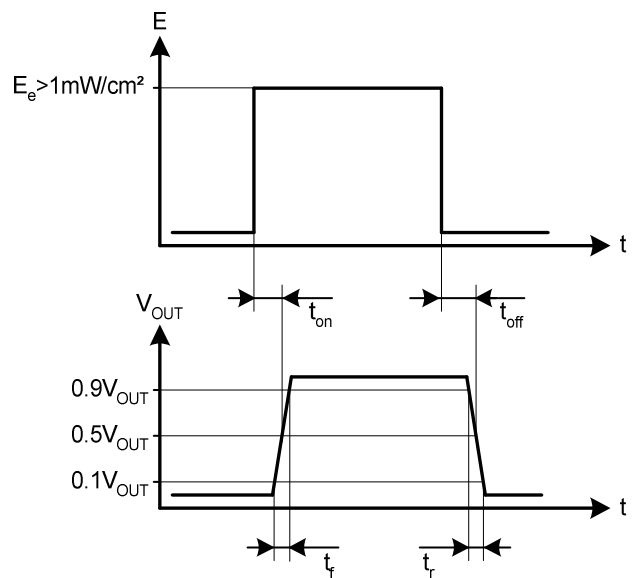

Definition of the rise and fall times



9 Applications Information

A typical connection diagram is shown in the figure below. A load resistor R_L is needed to get the voltage level out. The load capacitance C_L is typically formed by the input capacitance of the component that is connected to the sensor output, the wiring capacitance and the output capacitance of the sensor itself.

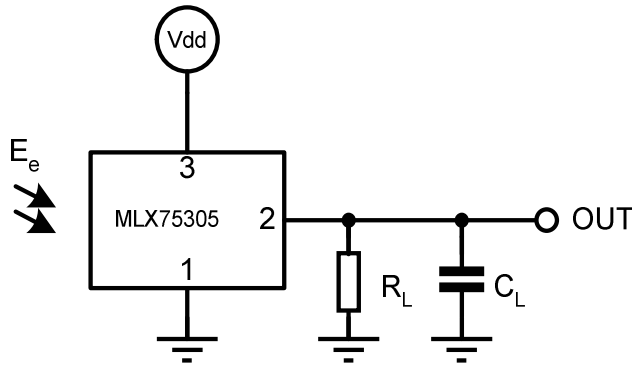

Decoupling capacitors between V_{dd} and V_{ss} (1 μ F in parallel with 100nF) are highly recommended in all configurations.

Recommendation: every change in the application should be agreed by both parties.



12 Standard information regarding manufacturability of Melexis products with different soldering processes

Our products are classified and qualified regarding soldering technology, solderability and moisture sensitivity level according to following test methods:

Reflow Soldering SMD's (Surface Mount Devices)

- IPC/JEDEC J-STD-020
Moisture/Reflow Sensitivity Classification for Nonhermetic Solid State Surface Mount Devices (classification reflow profiles according to table 5-2)
- EIA/JEDEC JESD22-A113
Preconditioning of Nonhermetic Surface Mount Devices Prior to Reliability Testing (reflow profiles according to table 2)

Wave Soldering SMD's (Surface Mount Devices)

- EN60749-20
Resistance of plastic- encapsulated SMD's to combined effect of moisture and soldering heat

Solderability SMD's (Surface Mount Devices)

- EIA/JEDEC JESD22-B102 and EN60749-21
Solderability

For all soldering technologies deviating from above mentioned standard conditions (regarding peak temperature, temperature gradient, temperature profile etc) additional classification and qualification tests have to be agreed upon with Melexis.

The application of Wave Soldering for SMD's is allowed only after consulting Melexis regarding assurance of adhesive strength between device and board.

Melexis is contributing to global environmental conservation by promoting **lead free** solutions. For more information on qualifications of **RoHS** compliant products (RoHS = European directive on the Restriction Of the use of certain Hazardous Substances) please visit the quality page on our website: <http://www.melexis.com/quality.asp>

13 ESD Precautions

Electronic semiconductor products are sensitive to Electro Static Discharge (ESD). Always observe Electro Static Discharge control procedures whenever handling semiconductor products.



14 Disclaimer

Devices sold by Melexis are covered by the warranty and patent indemnification provisions appearing in its Term of Sale. Melexis makes no warranty, express, statutory, implied, or by description regarding the information set forth herein or regarding the freedom of the described devices from patent infringement. Melexis reserves the right to change specifications and prices at any time and without notice. Therefore, prior to designing this product into a system, it is necessary to check with Melexis for current information. This product is intended for use in normal commercial applications. Applications requiring extended temperature range, unusual environmental requirements, or high reliability applications, such as military, medical life-support or life-sustaining equipment are specifically not recommended without additional processing by Melexis for each application.

The information furnished by Melexis is believed to be correct and accurate. However, Melexis shall not be liable to recipient or any third party for any damages, including but not limited to personal injury, property damage, loss of profits, loss of use, interrupt of business or indirect, special incidental or consequential damages, of any kind, in connection with or arising out of the furnishing, performance or use of the technical data herein. No obligation or liability to recipient or any third party shall arise or flow out of Melexis' rendering of technical or other services.

© 2005 Melexis NV. All rights reserved.

For additional information contact Melexis Direct:

Europe, Africa, Asia:	America:
Phone: +32 1367 0495	Phone: +1 603 223 2362
E-mail: sales_europe@melexis.com	E-mail: sales_usa@melexis.com

ISO/TS 16949 and ISO14001 Certified