

Features

- ◇ Glass passivated chip junction
- ◇ High efficiency, Low VF
- ◇ High current capability
- ◇ High reliability
- ◇ High surge current capability
- ◇ Low power loss
- ◇ Green compound with suffix "G" on packing code & prefix "G" on datecode

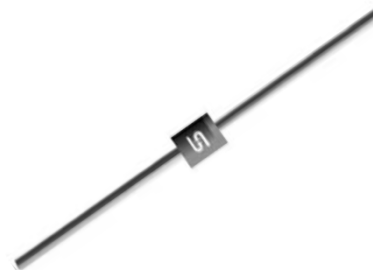

Mechanical Data

- ◇ Cases: Molded plastic DO-41
- ◇ Epoxy: UL 94V-0 rate flame retardant
- ◇ Lead: Pure tin plated, lead free, solderable per MIL-STD-202, Method 208 guaranteed
- ◇ Polarity: Color band denotes cathode end
- ◇ High temperature soldering guaranteed: 260°C/10s / .375", (9.5mm) lead lengths at 5 lbs, (2.3kg) tension
- ◇ Weight: 0.34 grams

Ordering Information (example)

Part No.	Package	Packing	INNER TAPE	Packing code	Green Compound Packing code
1N4933G	DO-41	3K / AMMO box	52mm	A0	A0G

Maximum Ratings and Electrical Characteristics

Rating at 25 °C ambient temperature unless otherwise specified.

Single phase, half wave, 60 Hz, resistive or inductive load.

For capacitive load, derate current by 20%

Type Number	Symbol	1N 4933G	1N 4934G	1N 4935G	1N 4936G	1N 4937G	Units
Maximum Recurrent Peak Reverse Voltage	V_{RRM}	50	100	200	400	600	V
Maximum RMS Voltage	V_{RMS}	35	70	140	280	420	V
Maximum DC Blocking Voltage	V_{DC}	50	100	200	400	600	V
Maximum Average Forward Rectified Current	$I_{F(AV)}$	1					A
Peak Forward Surge Current, 8.3 ms Single Half Sine-wave Superimposed on Rated Load (JEDEC method)	I_{FSM}	30					A
Maximum Instantaneous Forward Voltage (Note 1) @ 1 A	V_F	1.2					V
Maximum DC Reverse Current at @ $T_A=25^\circ\text{C}$ Rated DC Blocking Voltage @ $T_A=125^\circ\text{C}$	I_R	5 150					uA
Maximum Reverse Recovery Time (Note 2)	T_{rr}	200					nS
Typical Junction Capacitance (Note 3)	C_j	10					pF
Typical Thermal Resistance	$R_{\theta JA}$	65					°C/W
Operating Temperature Range	T_J	- 65 to + 150					°C
Storage Temperature Range	T_{STG}	- 65 to + 150					°C

Note1: Pulse Test with PW=300 usec, 1% Duty Cycle

Note2: Reverse Recovery Test Conditions: $I_F=1.0A$, $I_R=1.0A$, $IRR=0.25A$

Note3: Measured at 1 MHz and Applied Reverse Voltage of 4.0V D.C.

RATINGS AND CHARACTERISTIC CURVES (1N4933G THRU 1N4937G)

FIG. 1- MAXMUM FORWARD CURRENT DERATING CURVE

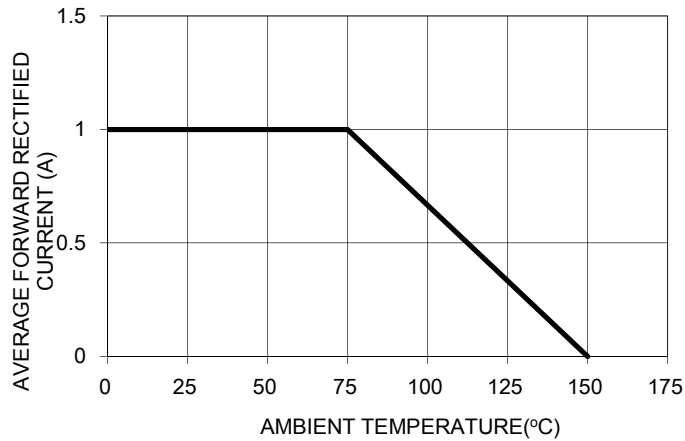

FIG. 2- TYPICAL REVERSE CHARACTERISTICS

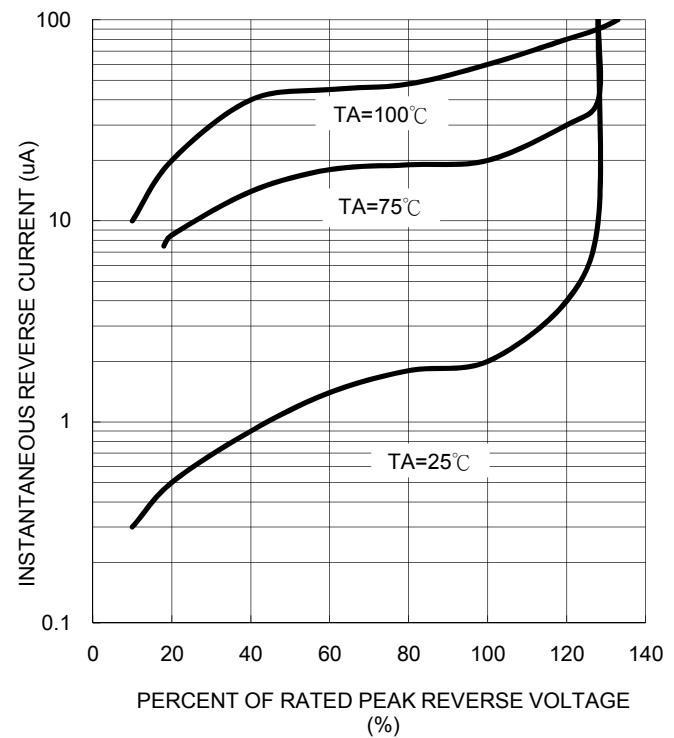

FIG. 3- MAXIMUM NON-REPETITIVE PEAK FORWARD SURGE CURRENT

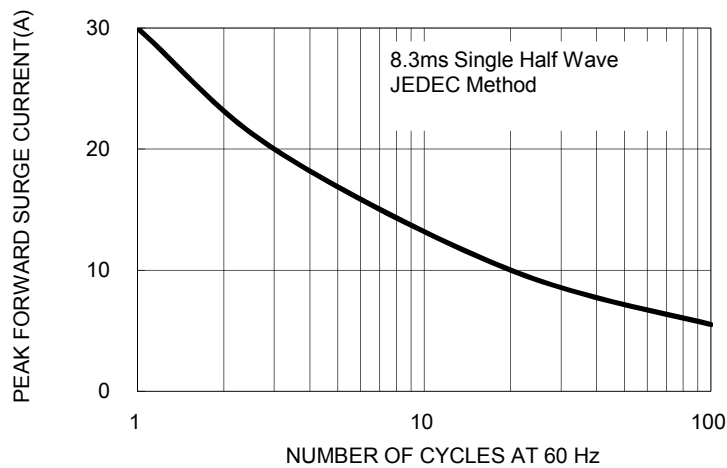

FIG. 5- TYPICAL FORWARD CHARACTERISTICS

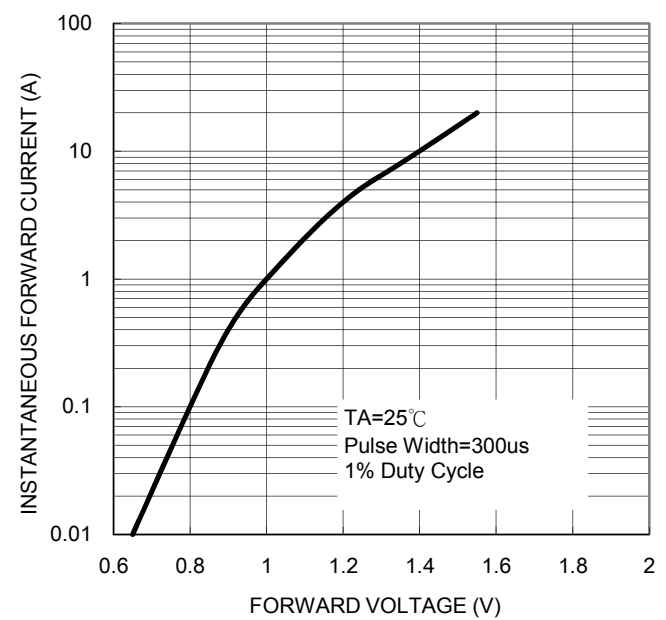

FIG. 4- TYPICAL JUNCTION CAPACITANCE

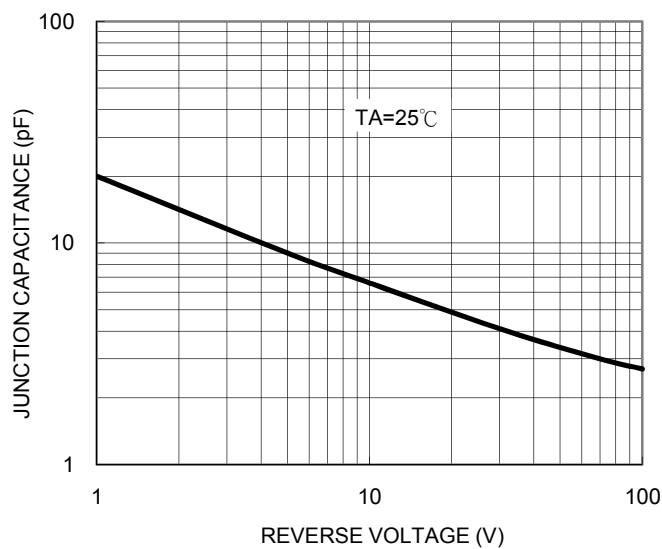
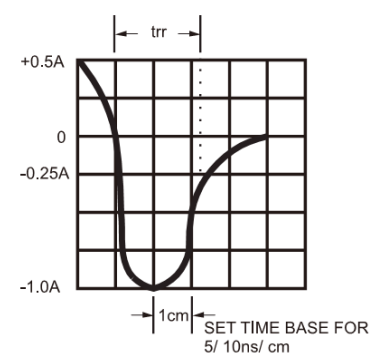
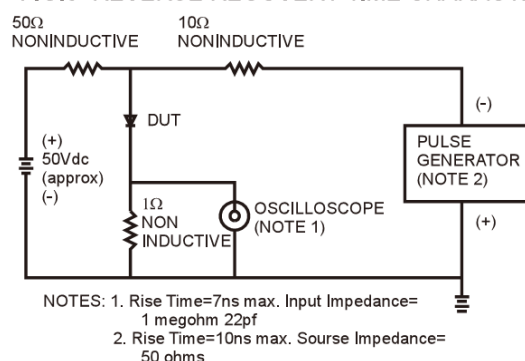

FIG. 6- REVERSE RECOVERY TIME CHARACTERISTIC AND TEST CIRCUIT DIAGRAM



Ordering information

Part No.	Package	Packing	INNER TAPE	Packing code	Green Compound Packing code
1N493xG	DO-41	3K / AMMO box	52mm	A0	A0G
	DO-41	5K / 13" Reel	52mm	R0	R0G
	DO-41	5K / 13" Reel	52mm	R1	R1G
	DO-41	1K / Bulk packing		B0	B0G
	DO-41	1K / Bulk packing		X0	X0G

Note: "x" is Device Code from "3" thru "7".

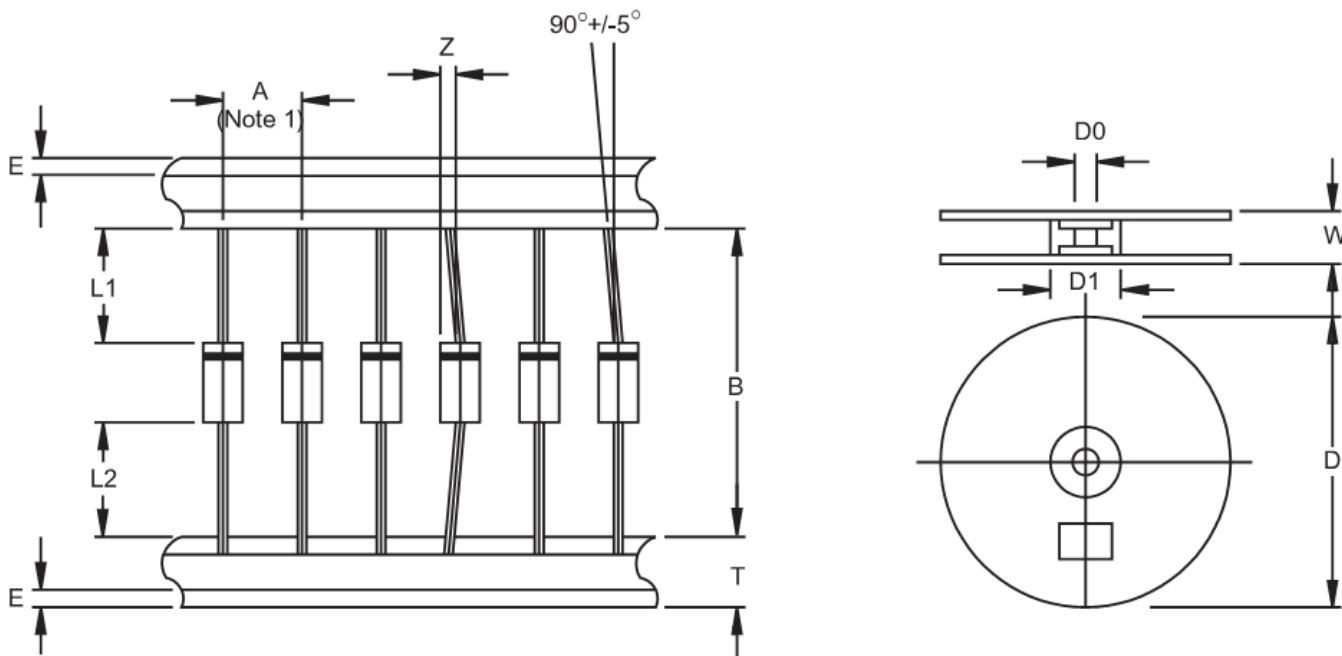
AXIAL LEAD TAPING SPECIFICATIONS

Outline	A	B	Z	T	E	L1-L2	D	D1	D0	W
	±0.5	±1.5	MAX	±0.4	MAX	MAX		±0.3	±0.4	±1.0
DO-41	5	52.4	1.2	6	0.8	1	330	85.7	16.6	76

Unit (mm)

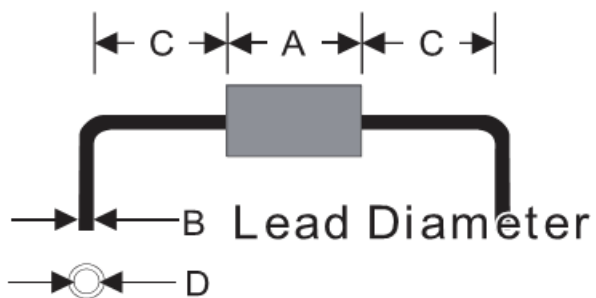
Suggested Mounting Hole Rule

Symbol	Unit(mm)
A	5.1
B	0.8
C	3.0
D	1.2

Dimensions

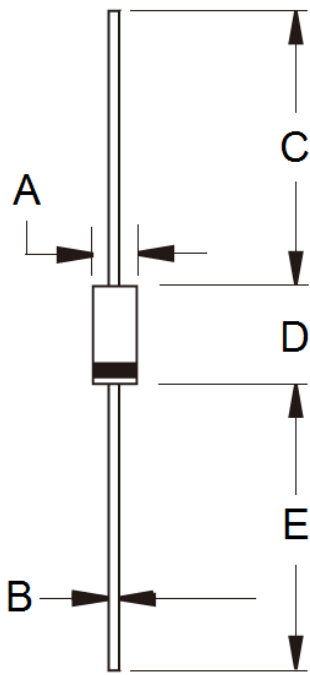

DIM.	Unit(mm)		Unit(inch)	
	Min	Max	Min	Max
A	2.00	2.70	0.079	0.106
B	0.71	0.86	0.028	0.034
C	25.40	-	1.000	-
D	4.20	5.20	0.165	0.205
E	25.40	-	1.000	-

Marking Diagram



- P/N = Specific Device Code
- G = Green Compound
- YWW = Date Code