

Features

- ✧ Glass passivated chip junction
- ✧ High efficiency, Low VF
- ✧ High current capability
- ✧ High reliability
- ✧ High surge current capability
- ✧ For use in low voltage, high frequency inverter, free wheeling, and polarity protection application
- ✧ Green compound with suffix "G" on packing code & prefix "G" on datecode



Mechanical Data

- ✧ Case: Molded plastic DO-41
- ✧ Epoxy: UL 94V-0 rate flame retardant
- ✧ Lead: Pure tin plated, lead free, solderable per MIL-STD-202, Method 208 guaranteed
- ✧ Polarity: Color band denotes cathode
- ✧ High temperature soldering guaranteed: 260°C/10s / .375", (9.5mm) lead lengths at 5 lbs, (2.3kg) tension
- ✧ Weight: 0.34 grams

Ordering Information (example)

Part No.	Package	Packing	INNER TAPE	Packing code	Green Compound Packing code
HER101G	DO-41	3K / AMMO box	52mm	A0	A0G

Maximum Ratings and Electrical Characteristics

Rating at 25 °C ambient temperature unless otherwise specified.

Single phase, half wave, 60 Hz, resistive or inductive load.

For capacitive load, derate current by 20%

Type Number	Symbol	HER 101G	HER 102G	HER 103G	HER 104G	HER 105G	HER 106G	HER 107G	HER 108G	Units
Maximum Recurrent Peak Reverse Voltage	V_{RRM}	50	100	200	300	400	600	800	1000	V
Maximum RMS Voltage	V_{RMS}	35	70	140	210	280	420	560	700	V
Maximum DC Blocking Voltage	V_{DC}	50	100	200	300	400	600	800	1000	V
Maximum Average Forward Rectified Current	$I_{F(AV)}$	1								A
Peak Forward Surge Current, 8.3 ms Single Half Sine-wave Superimposed on Rated Load (JEDEC method)	I_{FSM}	30								A
Maximum Instantaneous Forward Voltage (Note 1) @ 1 A	V_F	1.0			1.3		1.7			V
Maximum DC Reverse Current at @ $T_A=25\text{ }^\circ\text{C}$	I_R	5								uA
Rated DC Blocking Voltage @ $T_A=125\text{ }^\circ\text{C}$		150								
Maximum Reverse Recovery Time (Note 2)	T_{rr}	50				75				nS
Typical Junction Capacitance (Note 3)	C_j	15				10				pF
Typical Thermal Resistance	$R_{\theta JA}$	60								$^\circ\text{C/W}$
	$R_{\theta JC}$	15								
Operating Temperature Range	T_J	- 65 to + 150								$^\circ\text{C}$
Storage Temperature Range	T_{STG}	- 65 to + 150								$^\circ\text{C}$

Note 1: Pulse Test with PW=300 usec, 1% Duty Cycle

Note 2: Reverse Recovery Test Conditions: $I_F=0.5\text{A}$, $I_R=1.0\text{A}$, $IRR=0.25\text{A}$

Note 3: Measured at 1 MHz and Applied Reverse Voltage of 4.0V D.C.

RATINGS AND CHARACTERISTIC CURVES (HER101G THRU HER108G)

FIG. 1- MAXIMUM FORWARD CURRENT DERATING CURVE

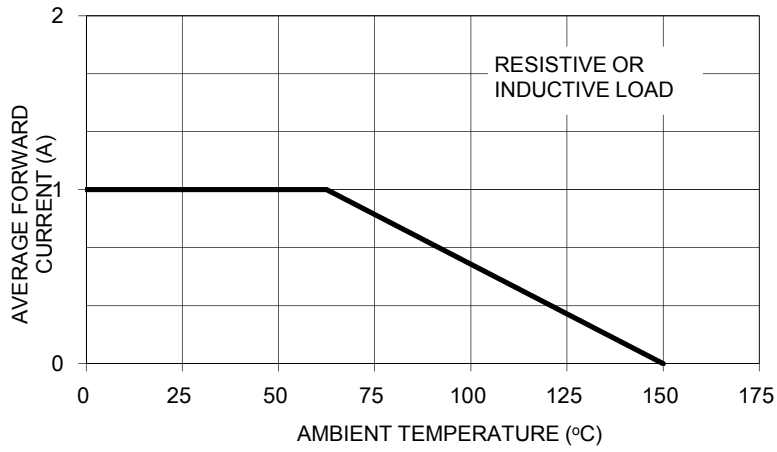

FIG. 2- TYPICAL REVERSE CHARACTERISTICS

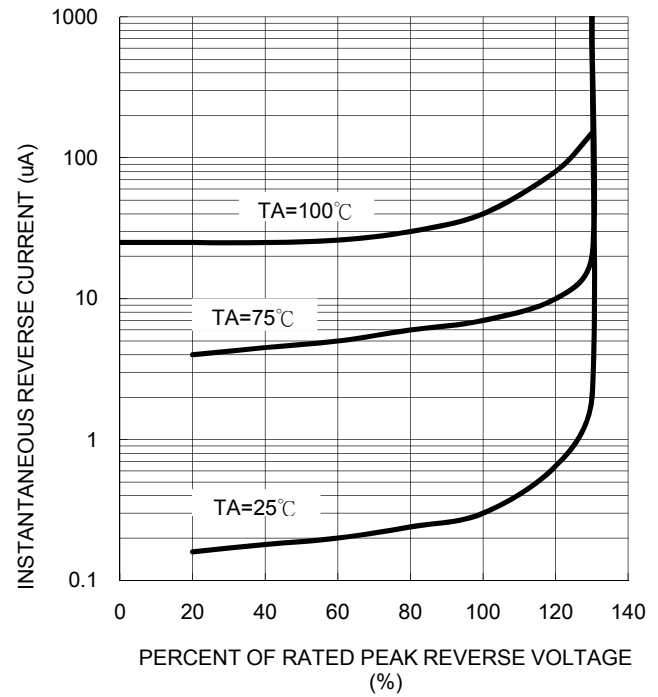

FIG. 3- MAXIMUM NON-REPETITIVE FORWARD SURGE CURRENT

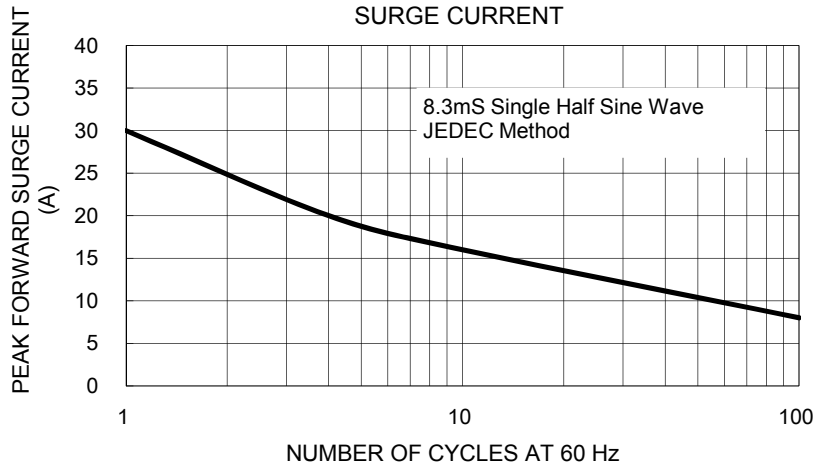

FIG. 5- TYPICAL INSTANTANEOUS FORWARD CHARACTERISTICS

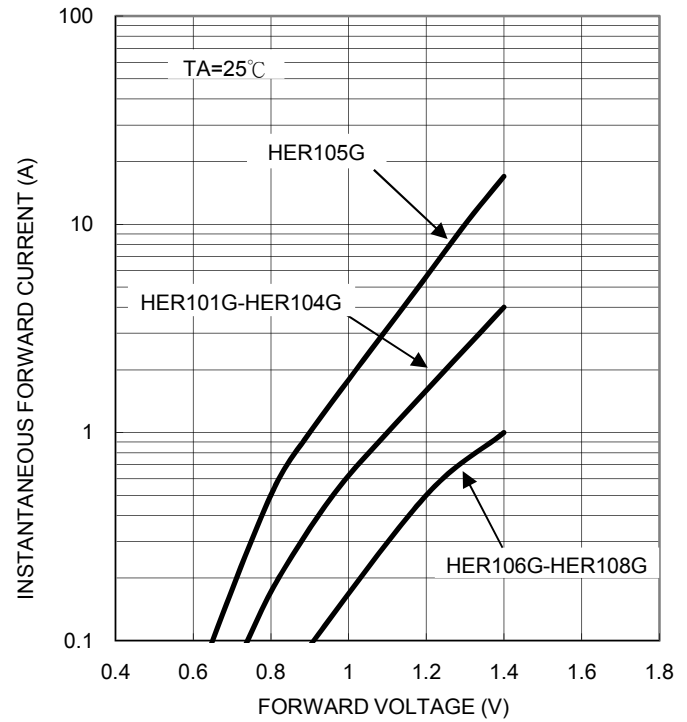

FIG. 4- TYPICAL JUNCTION CAPACITANCE

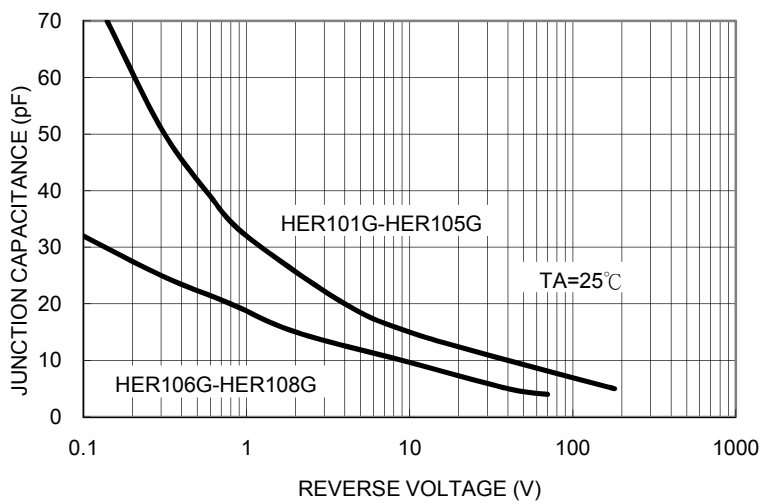
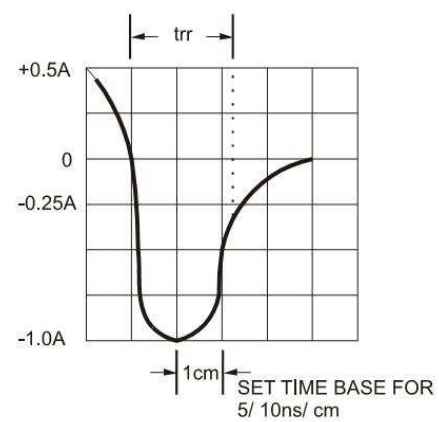
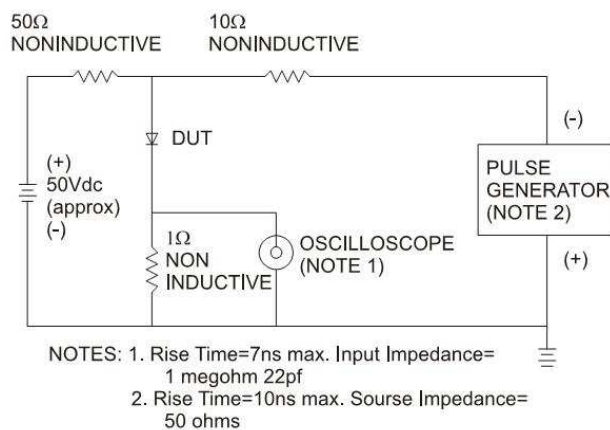

FIG. 6- REVERSE RECOVERY TIME CHARACTERISTIC AND TEST CIRCUIT DIAGRAM



Ordering information

Part No.	Package	Packing	INNER TAPE	Packing code	Green Compound Packing code
HER10xG	DO-41	3K / AMMO box	52mm	A0	A0G
	DO-41	5K / 13" Reel	52mm	R0	R0G
	DO-41	5K / 13" Reel	52mm	R1	R1G
	DO-41	1K / Bulk packing		B0	B0G
	DO-41	1K / Bulk packing		X0	X0G

Note: "x" is Device Code from "1" thru "8".

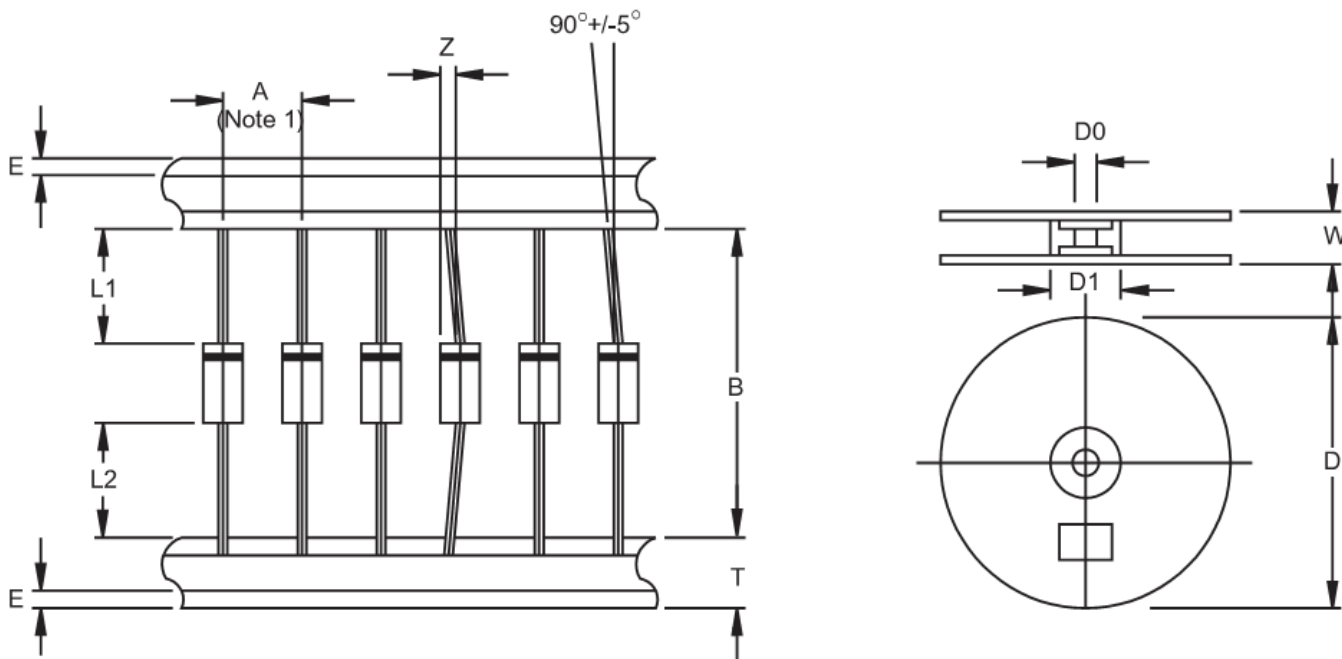
AXIAL LEAD TAPING SPECIFICATIONS

Outline	A	B	Z	T	E	L1-L2	D	D1	D0	W
		±0.5	±1.5	MAX	±0.4	MAX	MAX		±0.3	±0.4
DO-41	5	52.4	1.2	6	0.8	1	330	85.7	16.6	76

Unit (mm)

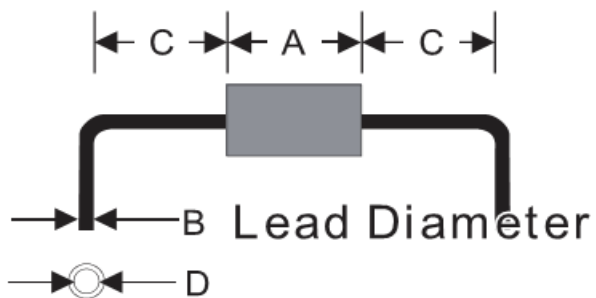
Suggested Mounting Hole Rule

Symbol	Unit(mm)
A	5.1
B	0.8
C	3.0
D	1.2

Dimensions

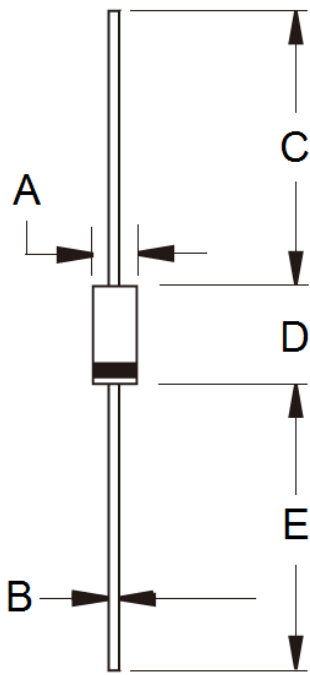

DIM.	Unit(mm)		Unit(inch)	
	Min	Max	Min	Max
A	2.00	2.70	0.079	0.106
B	0.71	0.86	0.028	0.034
C	25.40	-	1.000	-
D	4.20	5.20	0.165	0.205
E	25.40	-	1.000	-

Marking Diagram



- P/N = Specific Device Code
- G = Green Compound
- YWW = Date Code