

## Features

- ✧ Glass passivated junction chip.
- ✧ For surface mounted application
- ✧ Low forward voltage drop
- ✧ Low profile package
- ✧ Built-in stain relief, ideal for automatic placement
- ✧ Fast switching for high efficiency
- ✧ High temperature soldering:  
260°C/10 seconds at terminals
- ✧ Plastic material used carries Underwriters Laboratory Classification 94V-0
- ✧ Green compound with suffix "G" on packing code & prefix "G" on datecode



## Mechanical Data

- ✧ Case: Molded plastic
- ✧ Terminal: Pure tin plated, lead free
- ✧ Polarity: Indicated by cathode band
- ✧ Packing: 12mm tape per EIA STD RS-481
- ✧ Weight: 0.064 grams

## Ordering Information (example)

Part No.	Package	Packing	Packing code	Green Compound Packing code
HS2AA	SMA	1.8K / 7" REEL	R3	R3G

## Maximum Ratings and Electrical Characteristics

Rating at 25 °C ambient temperature unless otherwise specified.

Single phase, half wave, 60 Hz, resistive or inductive load.

For capacitive load, derate current by 20%

Type Number	Symbol	HS 2AA	HS 2BA	HS 2DA	HS 2FA	HS 2GA	HS 2JA	HS 2KA	HS 2MA	Unit	
Maximum Repetitive Peak Reverse Voltage	$V_{RRM}$	50	100	200	300	400	600	800	1000	V	
Maximum RMS Voltage	$V_{RMS}$	35	70	140	210	280	420	560	700	V	
Maximum DC Blocking Voltage	$V_{DC}$	50	100	200	300	400	600	800	1000	V	
Maximum Average Forward Rectified Current	$I_{F(AV)}$	1.5								A	
Peak Forward Surge Current, 8.3 ms Single Half Sine-wave Superimposed on Rated Load (JEDEC method)	$I_{FSM}$	50								A	
Maximum Instantaneous Forward Voltage (Note 1) @ 1.5A	$V_F$	1.0			1.3		1.7			V	
Maximum Reverse Current @ Rated VR $T_A=25\text{ }^\circ\text{C}$ $T_A=125\text{ }^\circ\text{C}$	$I_R$	5 100								$\mu\text{A}$	
Maximum Reverse Recovery Time (Note 2)	$T_{rr}$	50					75				nS
Typical Junction Capacitance (Note 3)	$C_j$	50					30				pF
Typical Thermal Resistance	$R_{\theta JA}$	80								$^\circ\text{C/W}$	
Operating Temperature Range	$T_J$	- 55 to + 150								$^\circ\text{C}$	
Storage Temperature Range	$T_{STG}$	- 55 to + 150								$^\circ\text{C}$	

Note 1: Pulse Test with PW=300 usec, 1% Duty Cycle

Note 2: Reverse Recovery Test Conditions:  $I_F=0.5\text{A}$ ,  $I_R=1.0\text{A}$ ,  $I_{RR}=0.25\text{A}$

Note 3: Measured at 1 MHz and Applied Reverse Voltage of 4.0V D.C.

## RATINGS AND CHARACTERISTIC CURVES (HS2AA THRU HS2MA)

FIG.1 FORWARD CURRENT DERATING CURVE

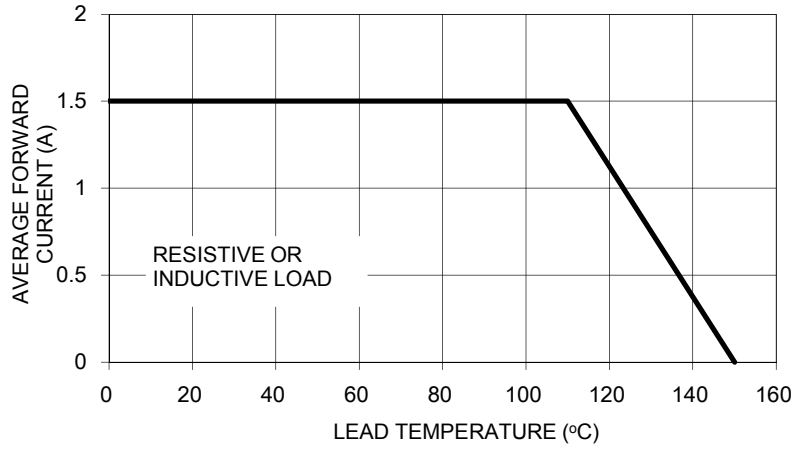

FIG. 2 TYPICAL REVERSE CHARACTERISTICS

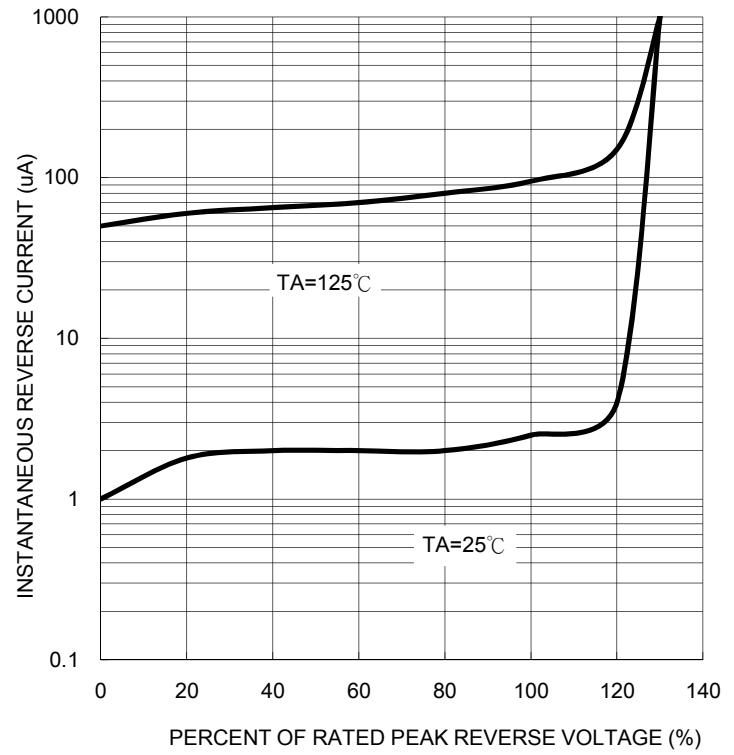

FIG. 3 MAXIMUM NON-REPETITIVE FORWARD SURGE CURRENT

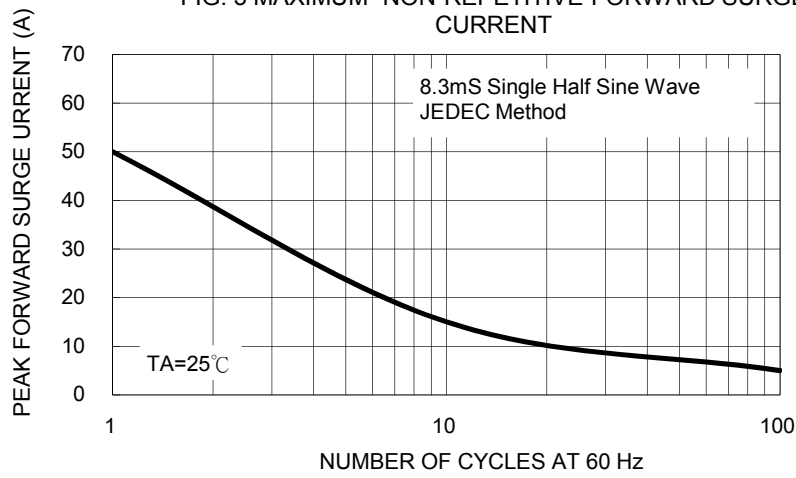

FIG. 5 TYPICAL FORWARD CHARACTERISTICS

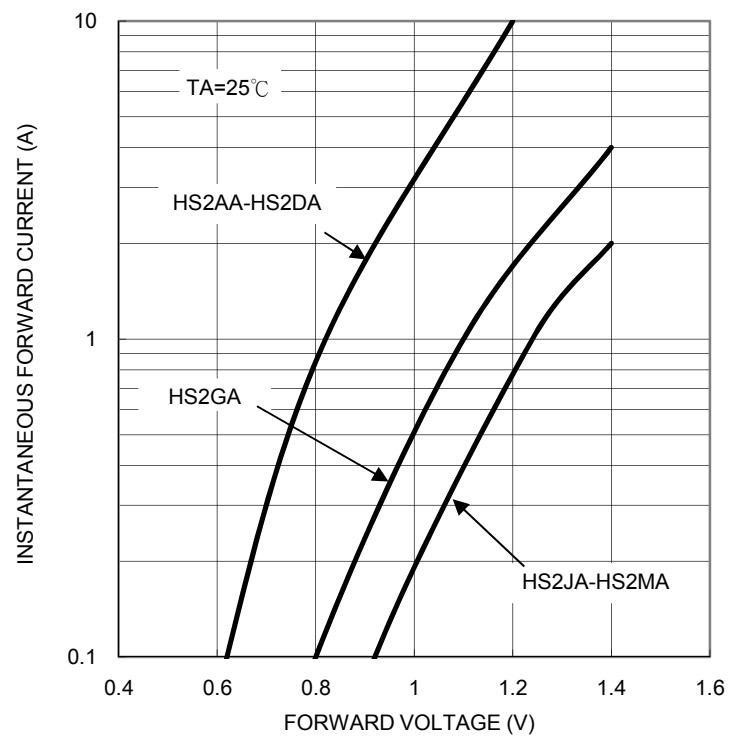

FIG. 4 TYPICAL JUNCTION CAPACITANCE

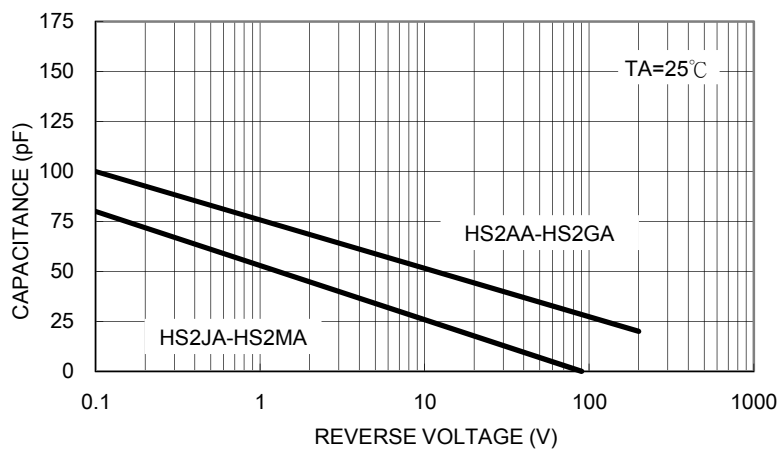
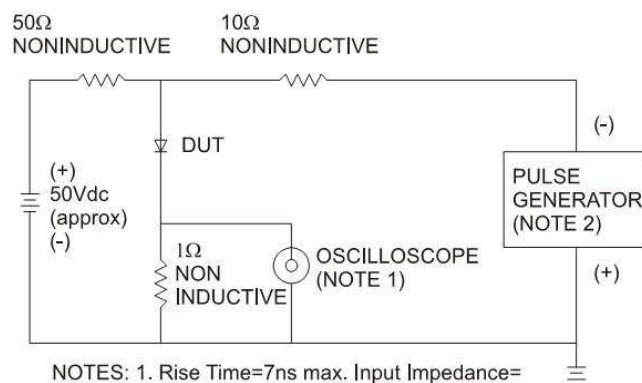
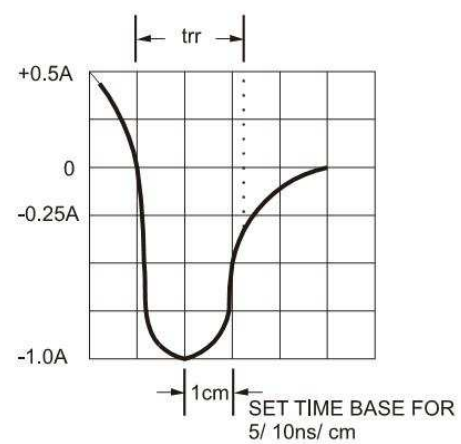

FIG.6- REVERSE RECOVERY TIME CHARACTERISTIC AND TEST CIRCUIT DIAGRAM



NOTES: 1. Rise Time=7ns max. Input Impedance= 1 megohm 22pf  
2. Rise Time=10ns max. Source Impedance= 50 ohms



**Ordering information**

Part No.	Package	Packing	Packing code	Green Compound Packing code
HS2xA (Note)	SMA	1.8K / 7" REEL	R3	R3G
	SMA	7.5K / 13" REEL	R2	R2G
	SMA	7.5K / 13" REEL	M2	M2G
	Folded SMA	1.8K / 7" REEL	F3	F3G
	Folded SMA	7.5K / 13" REEL	F2	F2G
	Folded SMA	7.5K / 13" REEL	F4	F4G
	C SMA	1.8K / 7" REEL	E3	E3G
	C SMA	7.5K / 13" REEL	E2	E2G
	C SMA	7.5K / 13" REEL	E4	E4G

Note: "x" is Device Code from "A" thru "M".

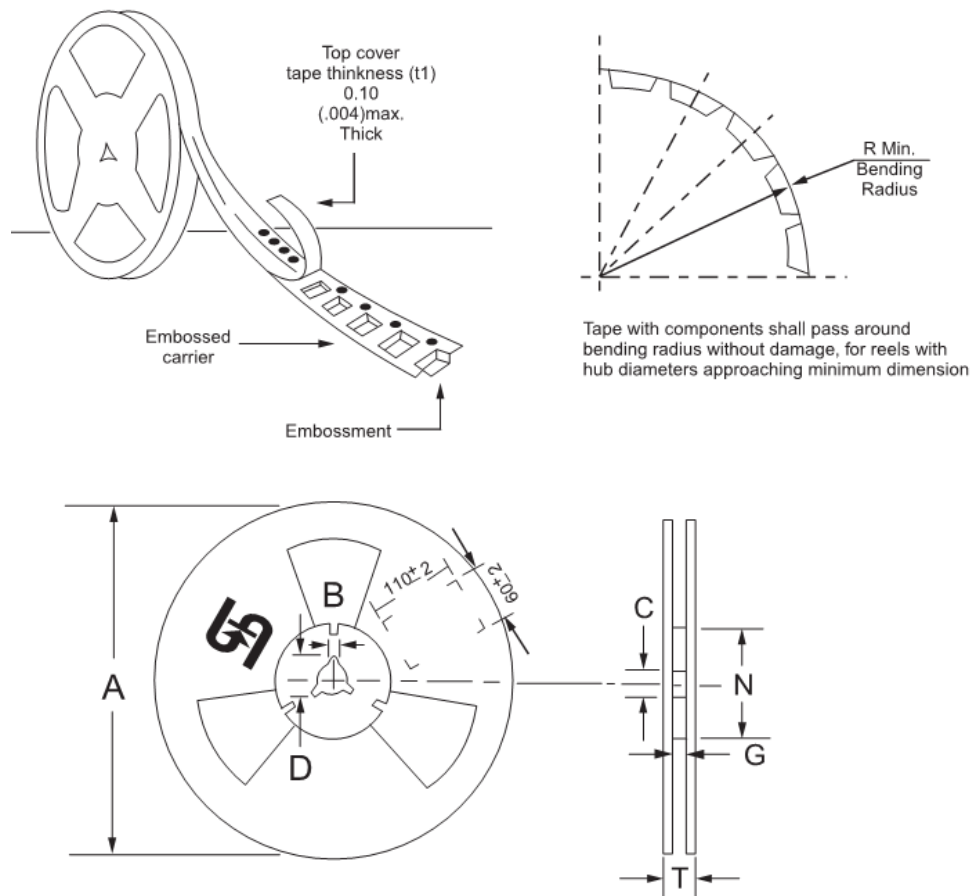
**Tape & Reel specification**

Reel Size	Tape Size	A	B	C	D	N	G	T
		±2.0	±0.4	+0.5;-0.2	min	±1.0	+0.8;-0	max
7"	12mm	178	1.9	13	21	62	12.2	14.6
Reel Size	Tape Size	A	B	C	D	N	G	T
		max	±0.5	±0.5	min	±0.5	+2.0;-0	max
13"	12mm	330	2	13	20.2	75	12.4	18.4

Unit (mm)

### Suggested PAD Layout

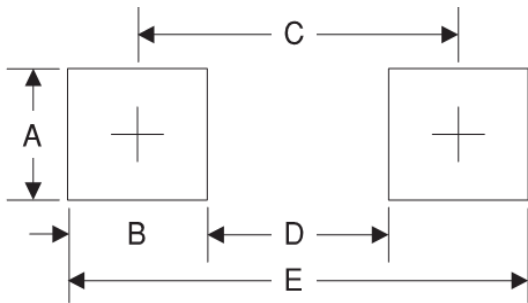

Symbol	Unit(mm)
A	1.78
B	1.51
C	3.92
D	2.41
E	4.43

### Package Outline Dimensions

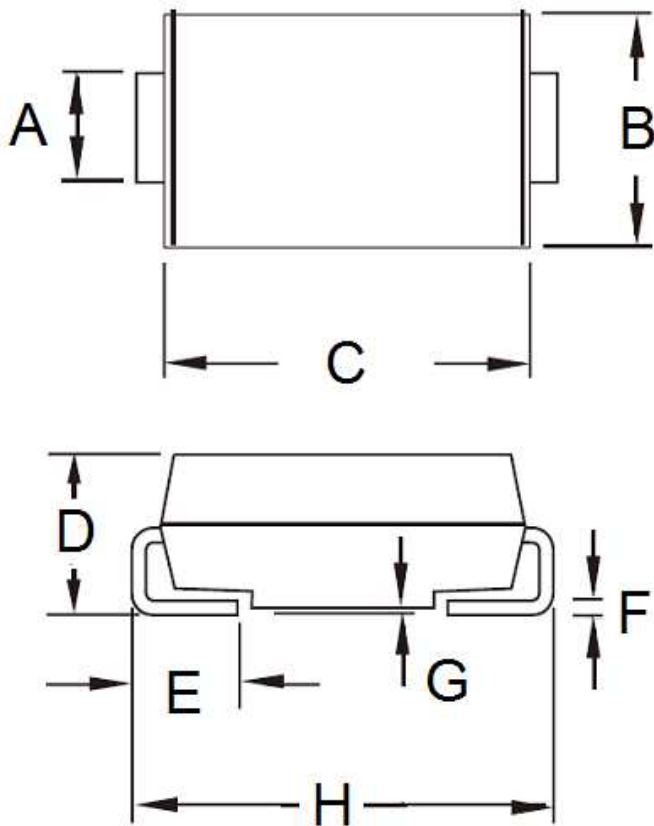

DIM.	Unit(mm)		Unit(inch)	
	Min	Max	Min	Max
A	1.27	1.58	0.050	0.062
B	2.29	2.83	0.090	0.111
C	4.06	4.60	0.160	0.181
D	1.99	2.50	0.078	0.098
E	0.90	1.41	0.035	0.056
F	0.15	0.31	0.006	0.012
G	0.10	0.20	0.004	0.008
H	4.95	5.33	0.195	0.210

### Marking Diagram

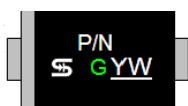

P/N = Specific Device Code  
 G = Green Compound  
 YW = Date Code