



BAT42W - BAT43W

200mW Surface Mount Schottky Barrier Diode
SOD-123

Features

- ✧ Low Forward Voltage Drop
- ✧ Surface mount package ideally suited for automatic insertion
- ✧ Moisture sensitivity level 1
- ✧ High temperature soldering guaranteed: 260°C/10 seconds
- ✧ Green compound (Halogen free)with suffix "G" on packing code and prefix "G" on date code.

Mechanical Data

- ✧ Case : SOD-123 plastic package
- ✧ Terminal: Matte tin plated, lead free., solderable per MIL-STD-202, Method 208 guaranteed
- ✧ Polarity : Cathode Band
- ✧ Marking : BAT42W - S7
BAT43W - S8
- ✧ Weight : 0.01gram (Approx.)

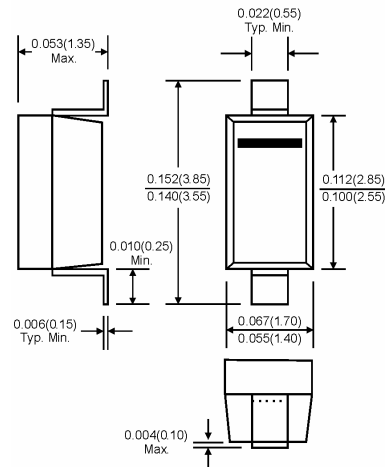

Dimensions in inches and (millimeters)



Cathode Anode

Electrical Symbol

Maximum Ratings and Electrical Characteristics

Rating at 25°C ambient temperature unless otherwise specified.

Single phase, half wave, 60 Hz, resistive or inductive load.

For capacitive load, derate current by 20%

Type Number	Symbol	BAT42W	BAT43W	Units
Repetitive Peak Reverse Voltage	V_{RRM}	30		V
Working Peak Reverse Voltage	V_{RWM}	21		V
DC Blocking Voltage	V_R	21		V
RMS Reverse Voltage	$V_{R(RMS)}$	21		V
Forward Continue Current (Note 1)	I_{FM}	200		mA
Peperitive Peak Forward Current @ $t < 1.0S$	I_{FM}	500		mA
Non-Repetitive Peak Forward Surge Current @ $t < 1.0mS$	I_{FSM}	4.0		A
Repetitive Peak Forward Surge Current	I_{FRM}	625		mA
Power Dissipation (Note 1)	P_d	200		mW
Maximum Maximum Forward Voltage IF = 200mA IF = 2.0mA IF = 10mA IF = 15mA IF = 50mA	VF	1.0		V
		--	0.33	V
		0.40	--	
		--	0.45	
		0.65	--	
Peak Reverse Current @ $V_R=25V$ & $T_j=25^{\circ}C$ @ $V_R=25V$ & $T_j=100^{\circ}C$	IR	500 100		nA uA
Junction Capacitance $V_R=0, f=1.0MHz$	C_j	10		pF
Reverse Recovery Time (Note 2)	T_{rr}	5		nS
Thermal Resistance Junction to Ambient Air (Note 1)	$R_{\theta JA}$	625		nS
Operating Temperature Range	T_J	-65 to +125		$^{\circ}C$
Storage Temperature Range	T_{STG}	-65 to +125		$^{\circ}C$

Notes: 1. Valid Provided that Terminals are Kept at Ambient Temperature.

2. Reverse Recovery Test Conditions: $I_F=10mA$, $I_R=10mA$, $R_L=100\Omega$, $I_{RR}=1mA$

Ratings and Characteristics Curve (BAT42W - BAT43W)

FIG 1 Typical Forward Characteristics

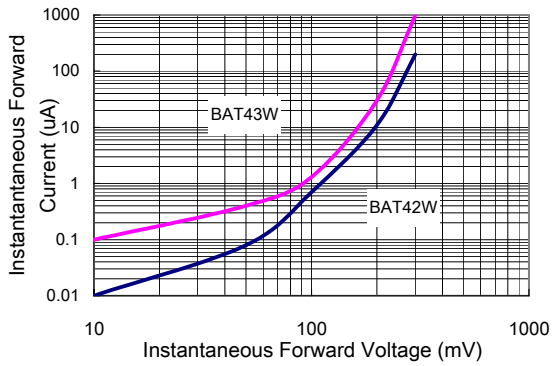

FIG 2 Typical Forward characteristics

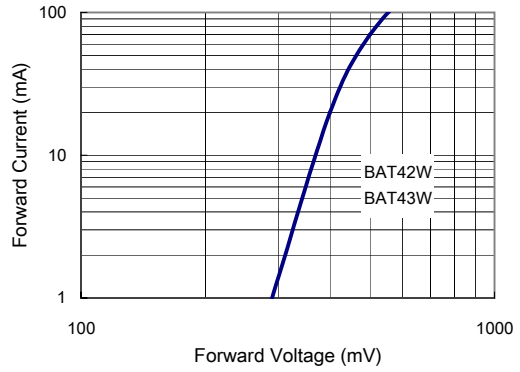

FIG 3 Typical Reverse Characteristics

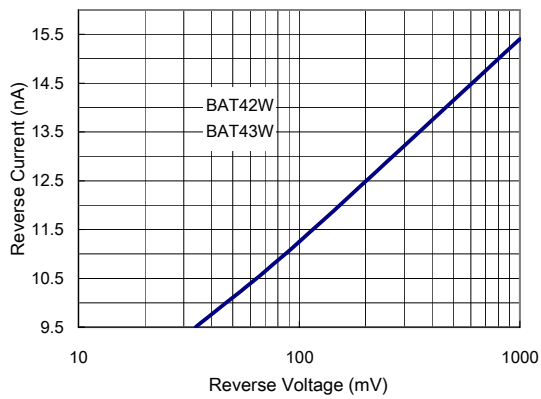

FIG 4 Typical Reverse Characteristics

