

Features

- ✧ Low power loss, high efficiency
- ✧ High current capability, Low VF
- ✧ High reliability
- ✧ High surge current capability
- ✧ Exitaxial construction
- ✧ Guard-ring for transient protection
- ✧ For use in low voltage, high frequency inverter, free wheeling, and polarity protection application
- ✧ Green compound with suffix "G" on packing code & prefix "G" on datecode

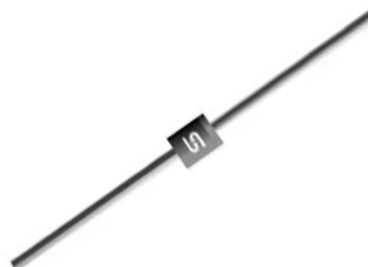

Mechanical Data

- ✧ Cases: DO-201AD molded plastic
- ✧ Epoxy: UL 94V-0 rate flame retardant
- ✧ Lead: Pure tin plated, lead free, solderable per MIL-STD-202, Method 208 guaranteed
- ✧ Polarity: Color band denotes cathode end
- ✧ High temperature soldering guaranteed: 260°C/10 seconds/.375" (9.5mm) lead lengths at 5 lbs., (2.3kg) tension
- ✧ Weight: 1.10 grams

Ordering Information (example)

Part No.	Package	Packing	INNER TAPE	Packing code	Green Compound Packing code
1N5820	DO-201AD	500 / AMMO box	52mm	A0	A0G

Maximum Ratings and Electrical Characteristics

Rating at 25 °C ambient temperature unless otherwise specified.

Single phase, half wave, 60 Hz, resistive or inductive load.

For capacitive load, derate current by 20%

Type Number	Symbol	1N5820	1N5821	1N5822	Units
Maximum Recurrent Peak Reverse Voltage	V_{RRM}	20	30	40	V
Maximum RMS Voltage	V_{RMS}	14	21	28	V
Maximum DC Blocking Voltage	V_{DC}	20	30	40	V
Maximum Average Forward Rectified Current	$I_{F(AV)}$	3			A
Peak Forward Surge Current, 8.3 ms Single Half Sine-wave Superimposed on Rated Load (JEDEC method)	I_{FSM}	70			A
Maximum Instantaneous Forward Voltage (Note 1) @ 3 A	V_F	0.475	0.500	0.525	V
Maximum DC Reverse Current @ $T_A=25\text{ }^\circ\text{C}$	I_R	0.5			mA
at Rated DC Blocking Voltage @ $T_A=100\text{ }^\circ\text{C}$		10			mA
Typical Junction Capacitance (Note 2)	C_j	200			pF
Typical Thermal Resistance (Note 3)	$R_{\theta JA}$	40			$^\circ\text{C/W}$
Operating Temperature Range	T_J	- 65 to + 125			$^\circ\text{C}$
Storage Temperature Range	T_{STG}	- 65 to + 125			$^\circ\text{C}$

Note 1: Pulse Test with PW=300 usec, 1% Duty Cycle

Note 2: Measure at 1 MHz and Applied Reverse Voltage of 4.0 V D.C.

RATINGS AND CHARACTERISTIC CURVES (1N5820 THRU 1N5822)

FIG. 1- MAXIMUM FORWARD CURRENT DERATING CURVE

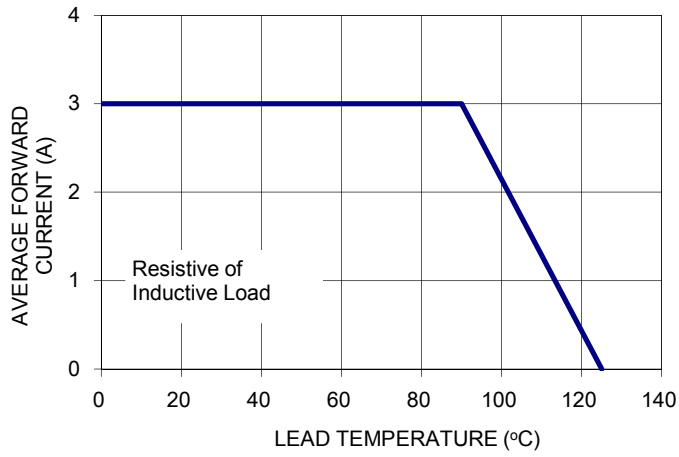

FIG. 2- MAXIMUM NON-REPETITIVE FORWARD SURGE CURRENT

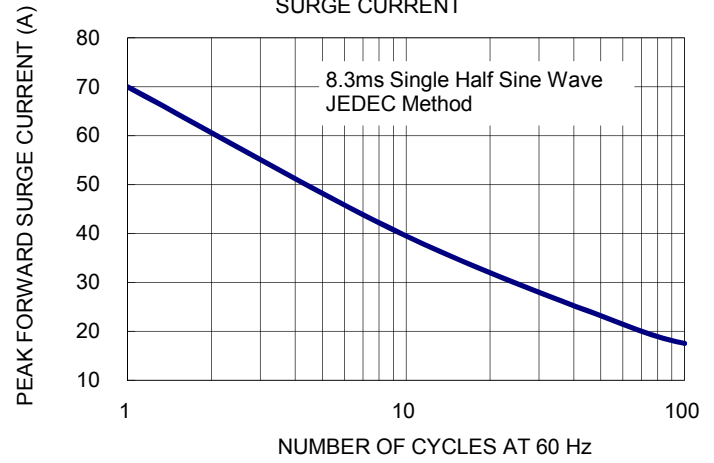

FIG. 3- TYPICAL FORWARD CHARACTERISTICS

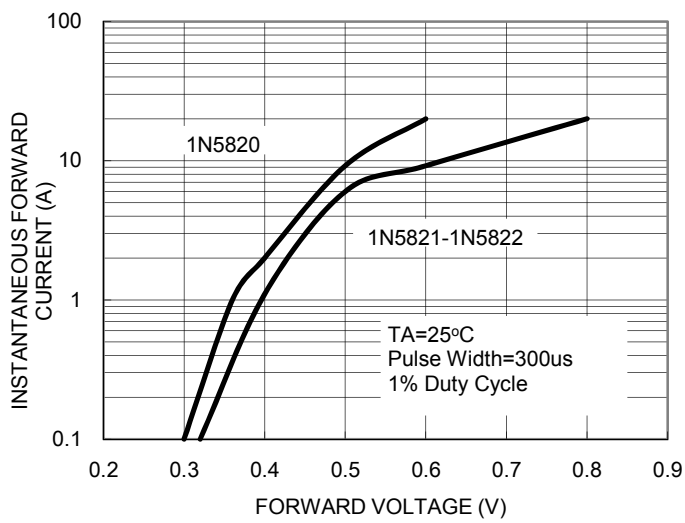

FIG. 4 TYPICAL REVERSE CHARACTERISTICS

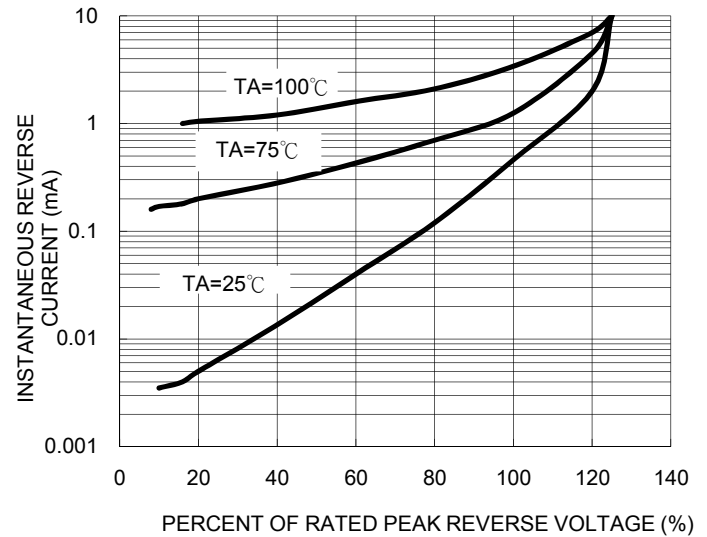

FIG. 5- TYPICAL JUNCTION CAPACITANCE

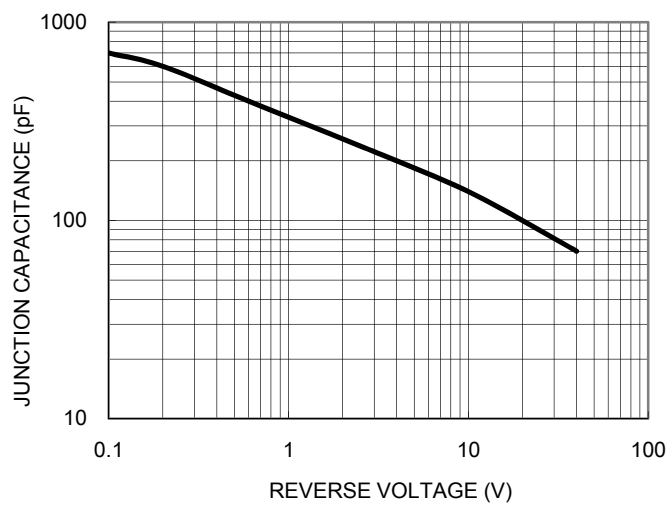
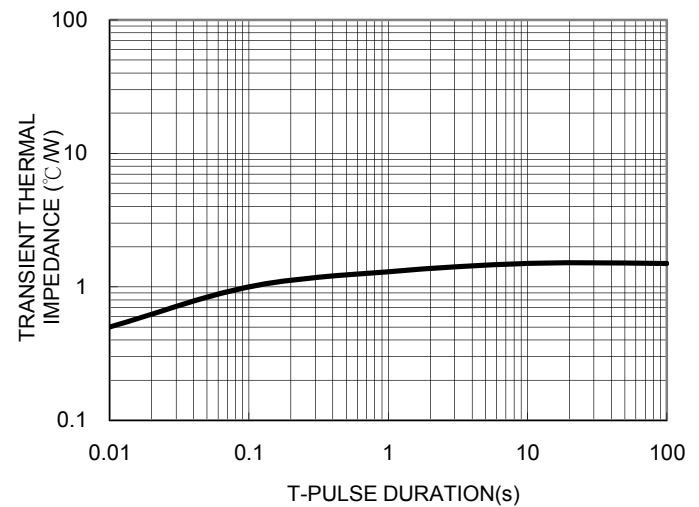

FIG. 6 TYPICAL TRANSIENT THERMAL IMPEDANCE PER LEG



Ordering information

Part No.	Package	Packing	INNER TAPE	Packing code	Green Compound Packing code
1N582x (Note)	DO-201AD	500 / AMMO box	52mm	A0	A0G
	DO-201AD	1.25K / 13" Reel	52mm	R0	R0G
	DO-201AD	500 / Bulk packing		B0	B0G
	DO-201AD	500 / Bulk packing		X0	X0G

Note: "x" is Device Code from "0" thru "2".

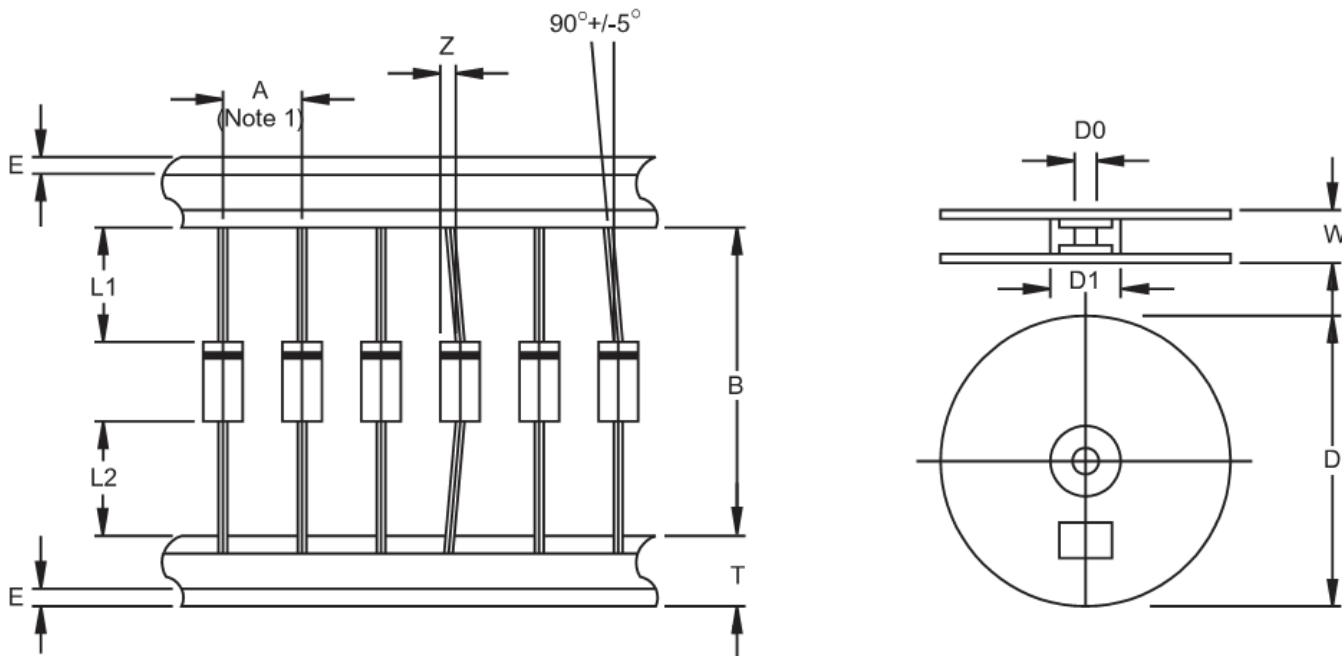
AXIAL LEAD TAPING SPECIFICATIONS

Outline	A	B	Z	T	E	L1-L2	D	D1	D0	W
		±0.5	±1.5	MAX	±0.4	MAX	MAX		±0.3	±0.4
DO-201AD	10	52.4	1.2	6	0.8	1	330	85.7	16.6	76

Unit (mm)

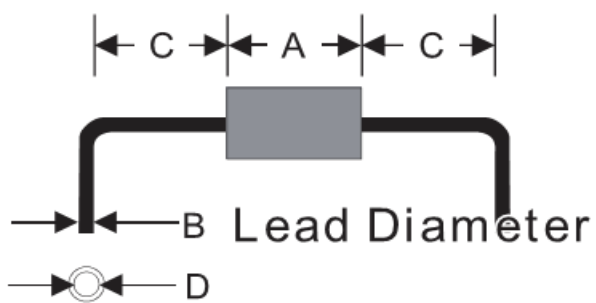
Suggested Mounting Hole Rule

Symbol	Unit(mm)
A	9.0
B	1.2
C	4.0
D	1.6

Dimensions

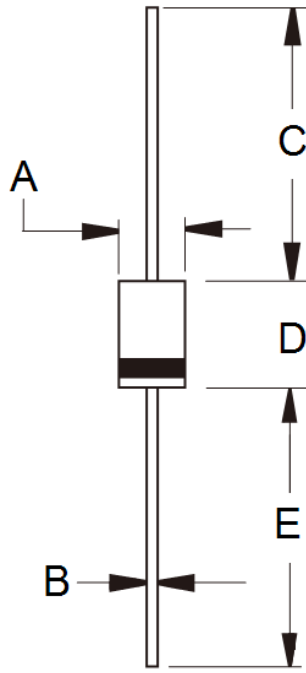

DIM.	Unit(mm)		Unit(inch)	
	Min	Max	Min	Max
A	5.00	5.60	0.197	0.220
B	1.20	1.30	0.048	0.052
C	25.40	-	1.000	-
D	8.50	9.50	0.335	0.375
E	25.40	-	1.000	-

Marking Diagram



- P/N = Specific Device Code
- G = Green Compound
- YWW = Date Code